

BURE

High Induction Diffuser

Handbook



Table of Contents

Description3
Dimensions & Weights6
Ordering Codes7
Quick Selection8
Technical Parameters9
Installation15
Transport, Storage and Operation22
Supplement23



Description

BURE is the adjustable geometry diffuser for comfort high capacity ventilation of big halls and industrial buildings. Suitable for heating and cooling. Installation height is between 4 m and 12 m, therefore the product is suitable for large industrial and public halls. The air discharge pattern (horizontal or vertical) can be adjusted manually (BURE-HC), by electric actuator (BURE-M2 and BURE-MC) or by thermal actuator (BURE-TC)

The control mechanism in HC, MC and TC version adjusts the flow pattern continuously in any selected position between entirely horizontal and entirely vertical discharge pattern adjustment.

The M2 version controls in a section of the range that can be shifted on the adjustment scale towards the horizontal flow pattern (in direction of pos. 1) or towards the vertical flow pattern (direction of pos. 5).

Highlights

- High capacity and very compact dimensions
- Large throw length at vertical discharge
- Small influence of geometry adjustment on pressure drop variation
- No influence of installation behind tee or elbow on the discharge pattern symmetry

Types of Product

- **BURE-HC**: diffuser with manual adjustment of the air discharge pattern
- **BURE-M2**: diffuser with 2-point or 3-point/ AC 230 V actuator
- **BURE-MC**: diffuser with continuous AC 24 V actuator with DC 0 V ... 10 V control signal for electric remote adjustment of the air discharge pattern
- **BURE-TC**: diffuser with thermal actuator for autonomous adjustment of the air discharge pattern dependent on the actual supply air temperature

Design

The BURE is made of powder coated steel and is available in the duct connection sizes 250 mm, 315 mm, 400 mm, 500 mm and 630 mm. At underside the double segment blinds allow the free area of more than 60%.

The BURE consists of an inlet spigot and an inner and outer cage with openings for supply air in the peripheral surface and the underside. Dependent of the operation method the openings in the peripheral surface (cooling, horizontal air stream) or the underside (heating, vertical air stream) are opened.

Product Parts

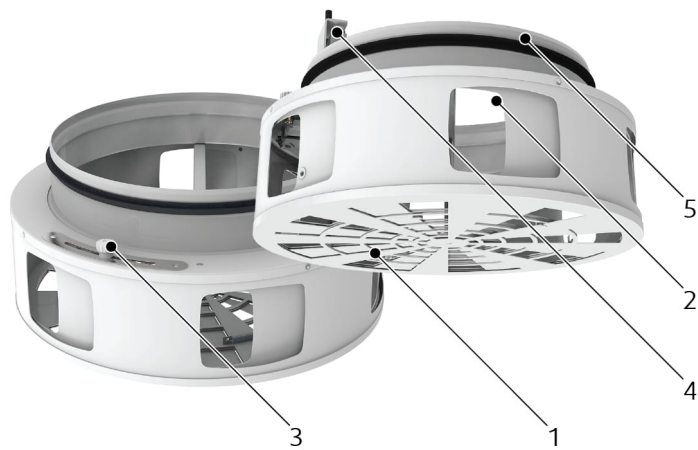

Legend

- 1 Vertical discharge vents
- 2 Horizontal discharge vents
- 3 Manual adjustment dial (BURE-HC, -M2)
- 4 Electric actuator (BURE-M2, -MC)
- 5 Duct connection with gasket

Setup Possibilities

• BURE-HC

Adjustment positions P1 ... P5

0% (P1) ... 100% (P5) opening for vertical air flow

• BURE-M2

Adjustment positions P1 ... P5

Manual shift of electro actuating mechanism towards the horizontal flow direction (P1) or towards the vertical flow direction (P5). This shift can be max. 1/2 of the full movement range between fully vertical (100%) and fully horizontal (0%) flow position. The resting 1/2 of the movement range is covered by the actuator.

• BURE-MC

For BURE-MC the control signal influences the opening of the vertical and horizontal flow direction.

DC 0 V ... 10 V changes the vertical flow opening from 0% to 100% and in the same time the horizontal opening in the inverse proportion.

• BURE-TC

This type is adjusted autonomously. The adjustment position depends only on the supply air temperature that controls the movement of the thermal actuator. At temperatures below 18 °C the adjustment is for entirely horizontal discharge (0%). From 18 °C to 32 °C the adjustment runs linearly decreasing the horizontal discharge and increasing the vertical part. With 32 °C or higher the entirely vertical discharge (100%) is adjusted.



Dimensions & Weights

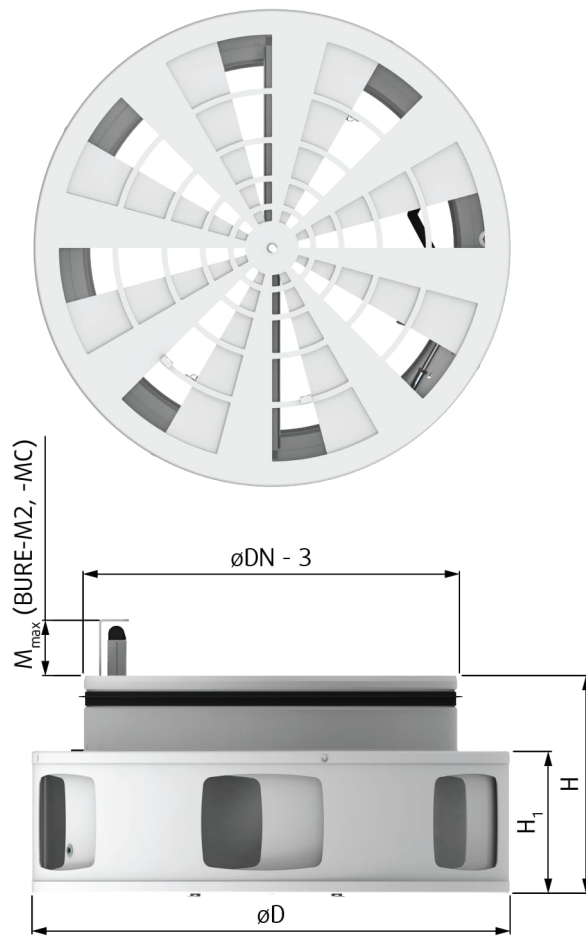

DN	$\varnothing D$	H	H_1	M_{max} (BURE... -M2, -MC)	BURE... -HC, -TC	BURE... -M2, -MC
mm					kg	
250	315	160	99	50	2,6	3,1
315	400	182	119	48	3,8	4,3
400	500	204	144	-	5,7	7,2
500	600	223	163		7,9	9,5
630	800	271	211		12,8	14,5

Ordering Codes

Nominal size (DN supply connection)

250

315

400

500

630

Type of control

HC Manual control

TC Thermal continuous control

M2 Electric actuator AC 230 V, 2-point/-3point control

MC Electric actuator AC 24 V, DC 0 V ... 10 V continuous control

Surface finish *

RAL9003 Signal white RAL9003, gloss 30%

RALXXXX Other RAL colours

NOTE: * If no Surface finish is defined, signal white RAL9003 powder coating will be delivered.

Example of the Ordering Code

BURE-400-MC

Variable geometry diffuser BURE, supply connection nominal size 400 mm, with AC 24 V electric drive for DC 0 V ... 10 V continuous control. Signal white powder coating RAL9003, gloss 30%.

Quick Selection

BURE-	q _v @ L _{WA}							
	30 dB		35 dB		40 dB		45 dB	
	m ³ /h	l/s	m ³ /h	l/s	m ³ /h	l/s	m ³ /h	l/s
250	357	99	466	129	595	165	756	210
315	560	156	731	203	922	256	1144	318
400	1090	303	1315	365	1564	434	1846	513
500	1184	329	1442	401	1740	483	2086	579
630	1910	531	2337	649	2793	776	3321	923

NOTE: The working points were measured with fully open bottom vents for vertical discharge (100% curve in diagram).

Technical Parameters

BURE-250-HC-SW

Pressure drop & A-weighted sound power level in dB(A)

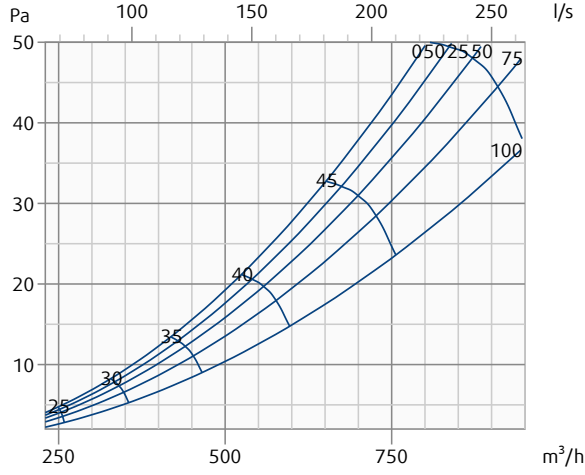

BURE-315-HC-SW

Pressure drop & A-weighted sound power level in dB(A)

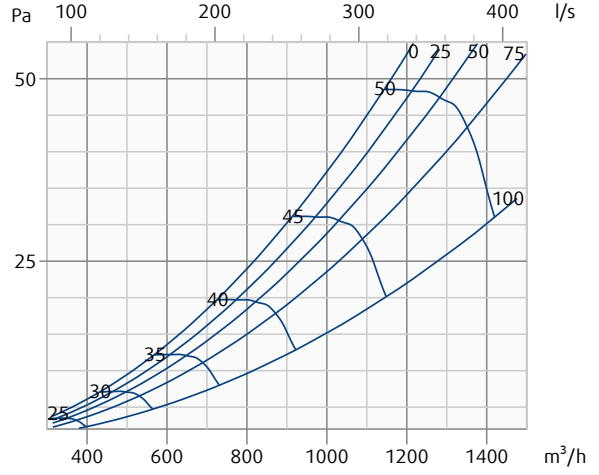

BURE-400-HC-SW

Pressure drop & A-weighted sound power level in dB(A)

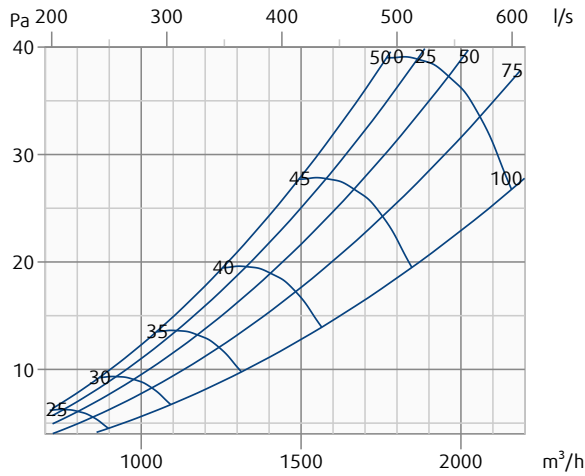

BURE-500-HC-SW

Pressure drop & A-weighted sound power level in dB(A)

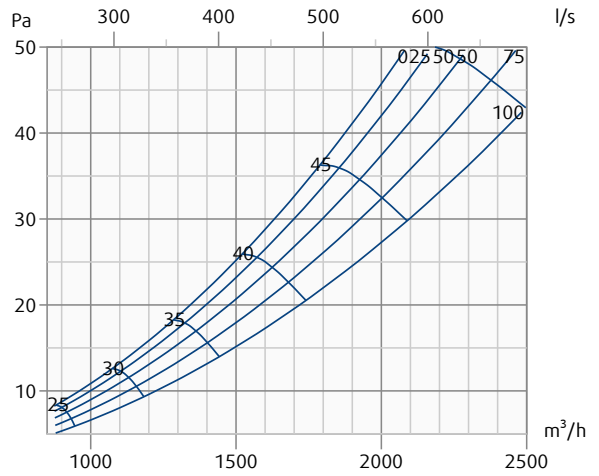

BURE-630-HC-SW

Pressure drop & A-weighted sound power level in dB(A)

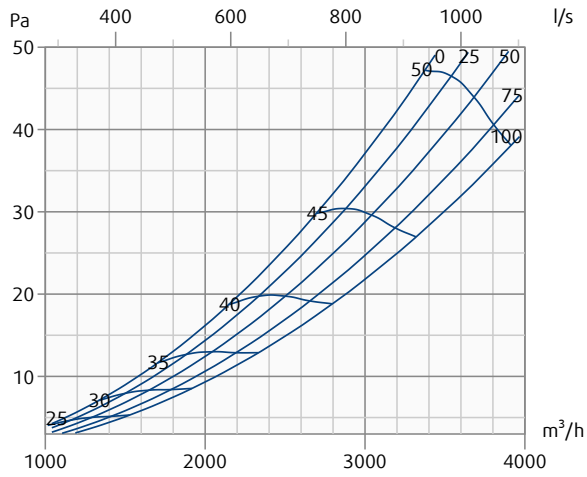

BURE-250-M2-SW

Pressure drop & A-weighted sound power level in dB(A)

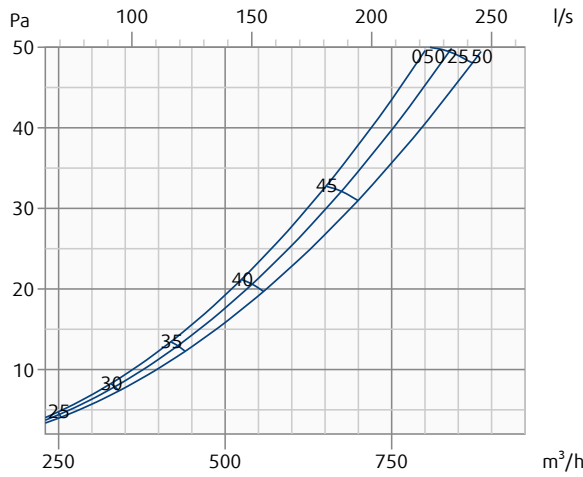

BURE-315-M2-SW

Pressure drop & A-weighted sound power level in dB(A)

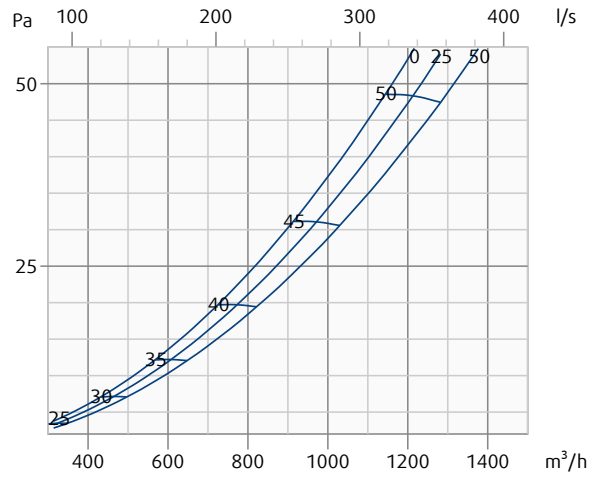

BURE-400-M2-SW

Pressure drop & A-weighted sound power level in dB(A)

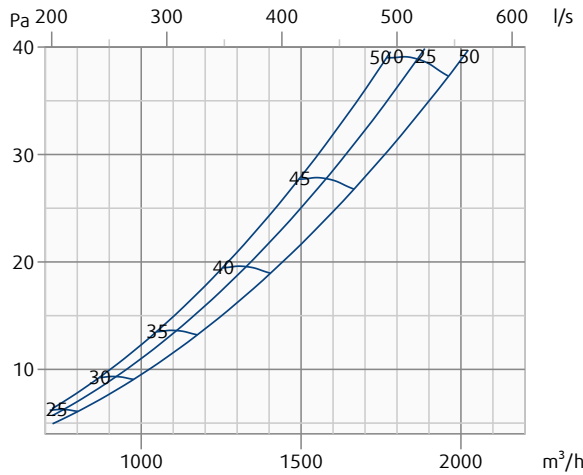

BURE-500-M2-SW

Pressure drop & A-weighted sound power level in dB(A)

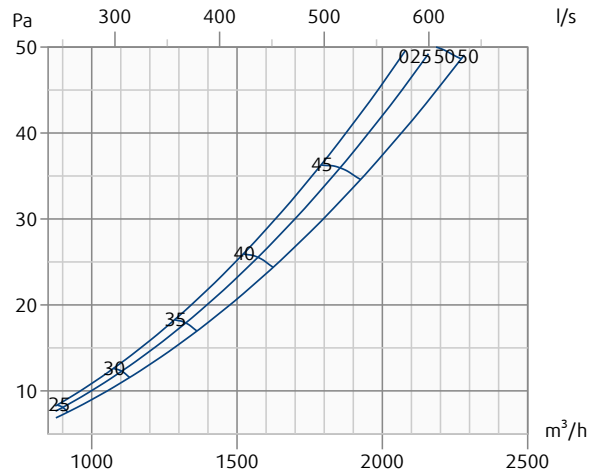

BURE-630-M2-SW

Pressure drop & A-weighted sound power level in dB(A)

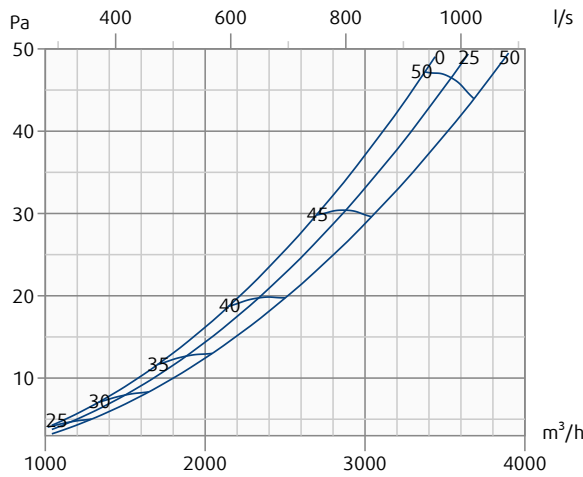

BURE-250-MC-SW

Pressure drop & A-weighted sound power level in dB(A)

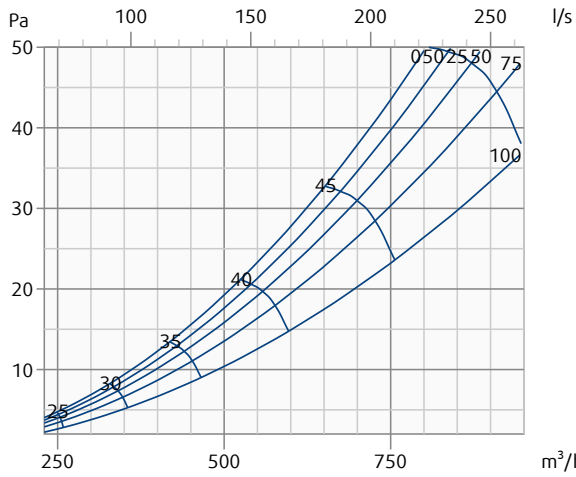

BURE-315-MC-SW

Pressure drop & A-weighted sound power level in dB(A)

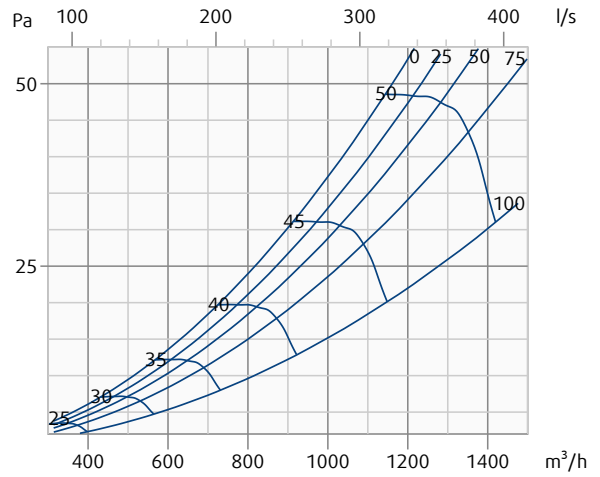

BURE-400-MC-SW

Pressure drop & A-weighted sound power level in dB(A)

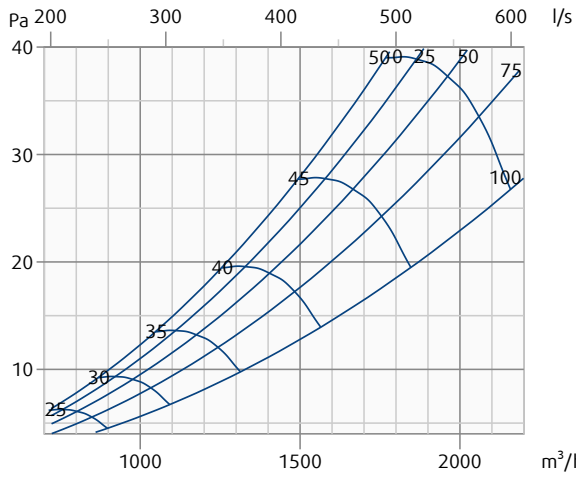

BURE-500-MC-SW

Pressure drop & A-weighted sound power level in dB(A)

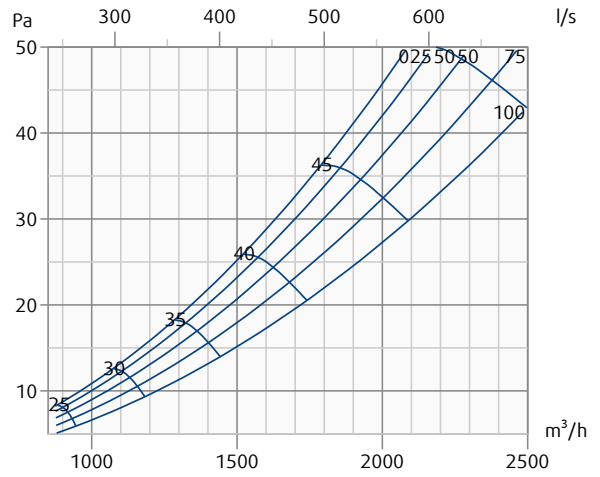

BURE-630-MC-SW

Pressure drop & A-weighted sound power level in dB(A)

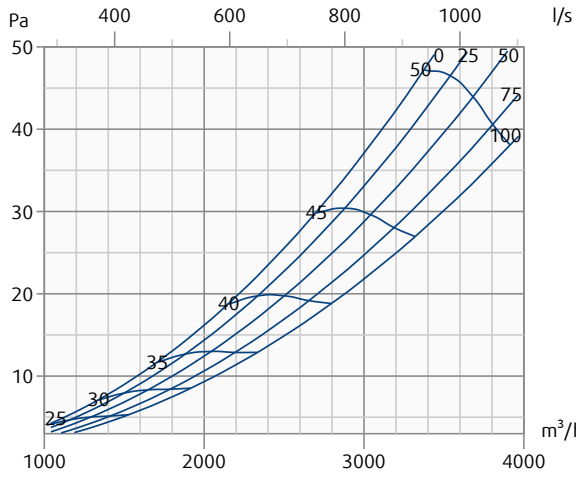

BURE-250-TC-SW

Pressure drop & A-weighted sound power level in dB(A)

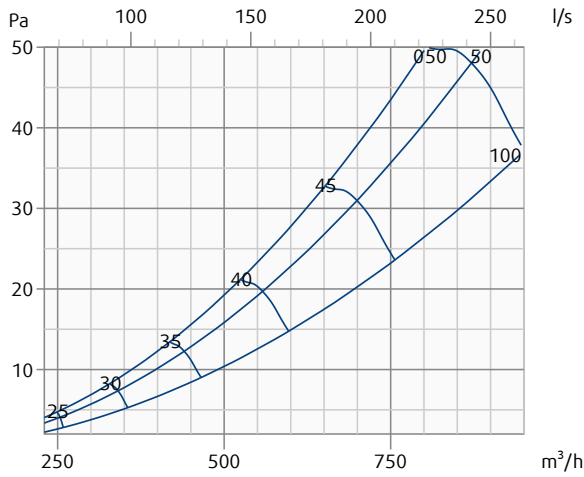

BURE-315-TC-SW

Pressure drop & A-weighted sound power level in dB(A)

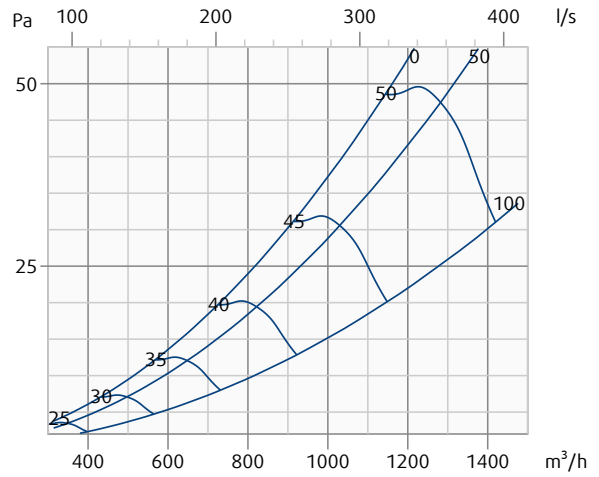

BURE-400-TC-SW

Pressure drop & A-weighted sound power level in dB(A)

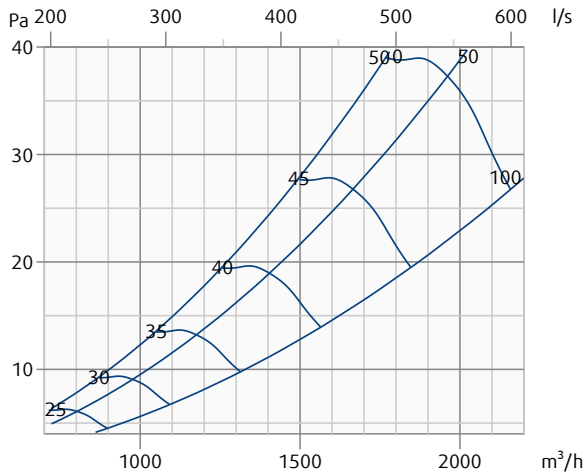

BURE-500-TC-SW

Pressure drop & A-weighted sound power level in dB(A)

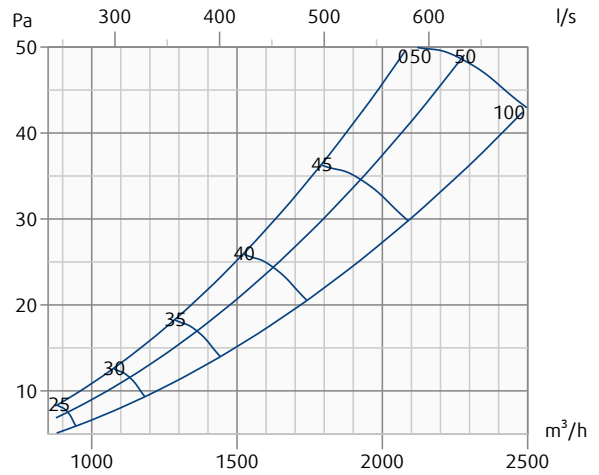

Notes: The adjustment positions on BURE-TC depend linearly and continuously on the supply air temperature. For temperatures lower or equal 18°C the position 0% is adjusted, for 25°C the position is 50% and for 32°C or higher temperature the position is 100%.

BURE-630-TC-SW

Pressure drop & A-weighted sound power level in dB(A)

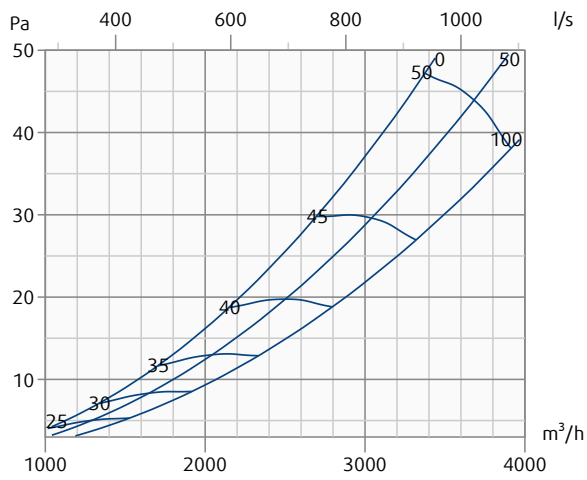

Notes: The adjustment positions on BURE-TC depend linearly and continuously on the supply air temperature. For temperatures lower or equal 18°C the position 0% is adjusted, for 25°C the position is 50% and for 32°C or higher temperature the position is 100%.

Installation



BURE-HC



BURE-M2



BURE-MC



BURE-TC



1.

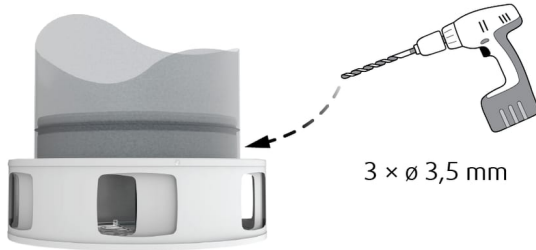

2.

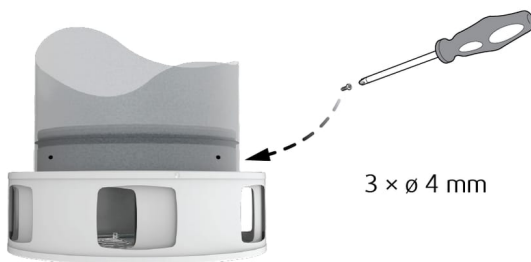

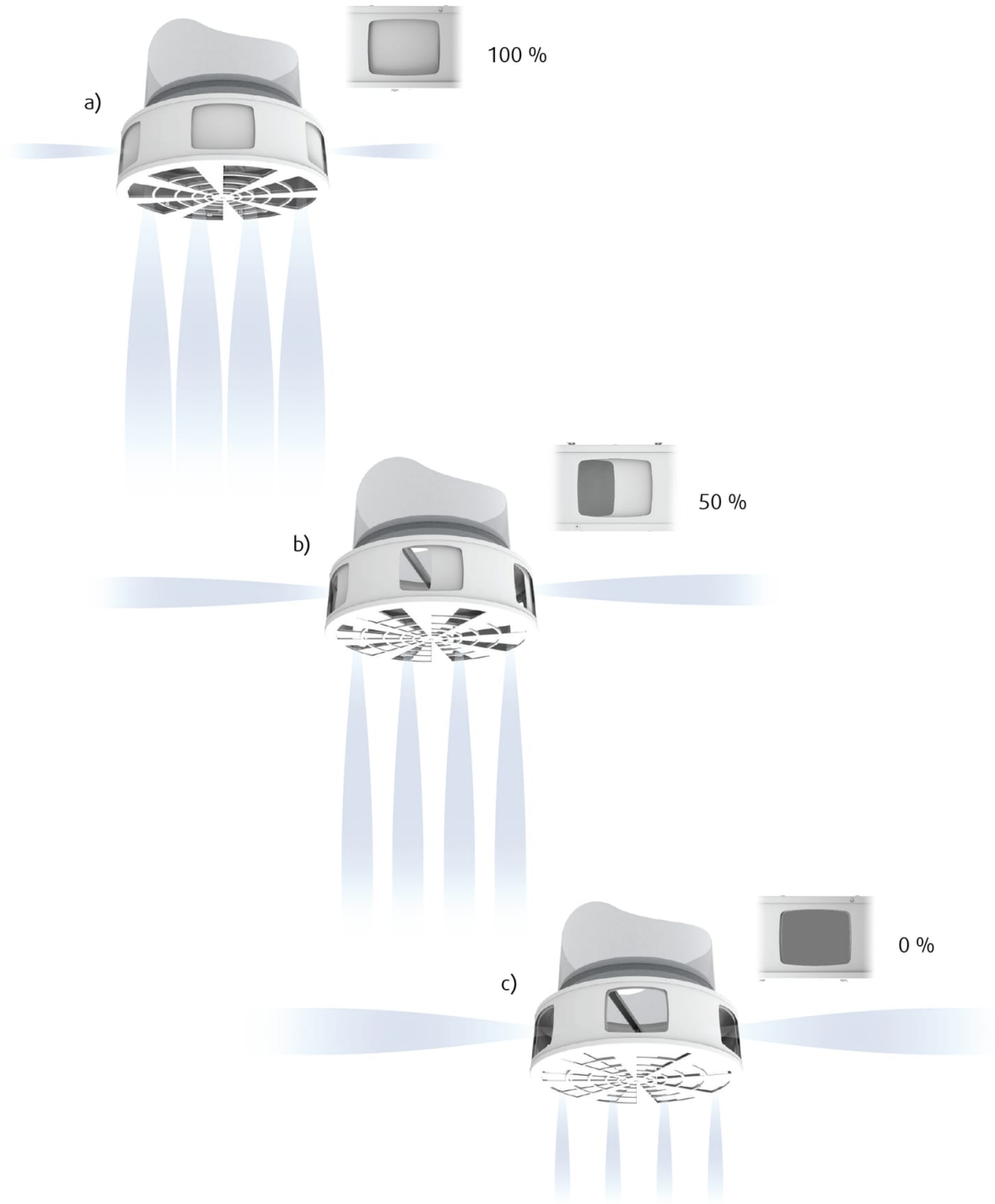

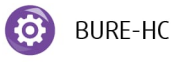

P5 ... P3 ... P1

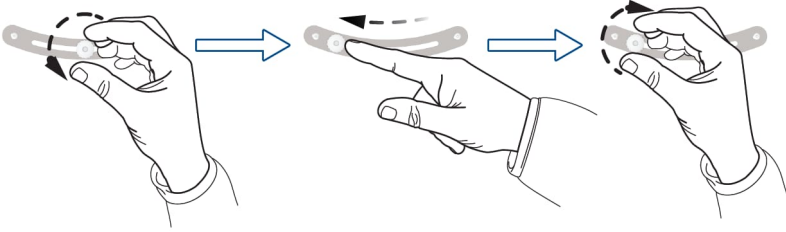



CM230-F10-L
BURE-M2-250
BURE-M2-315

/

LH230A100
BURE-M2-400
BURE-M2-500
BURE-M2-630

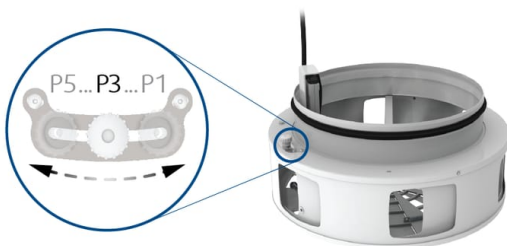
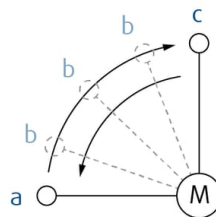
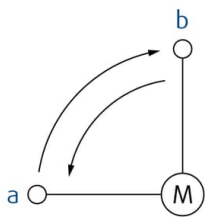
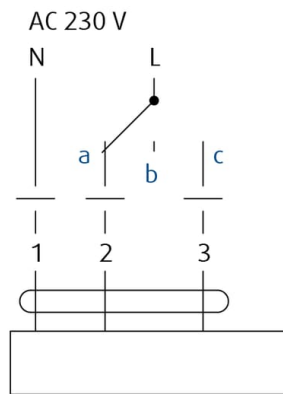
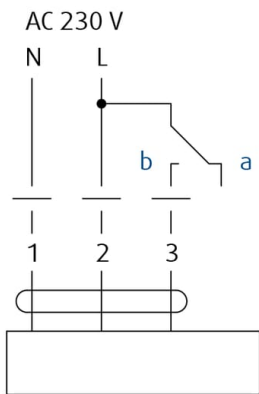

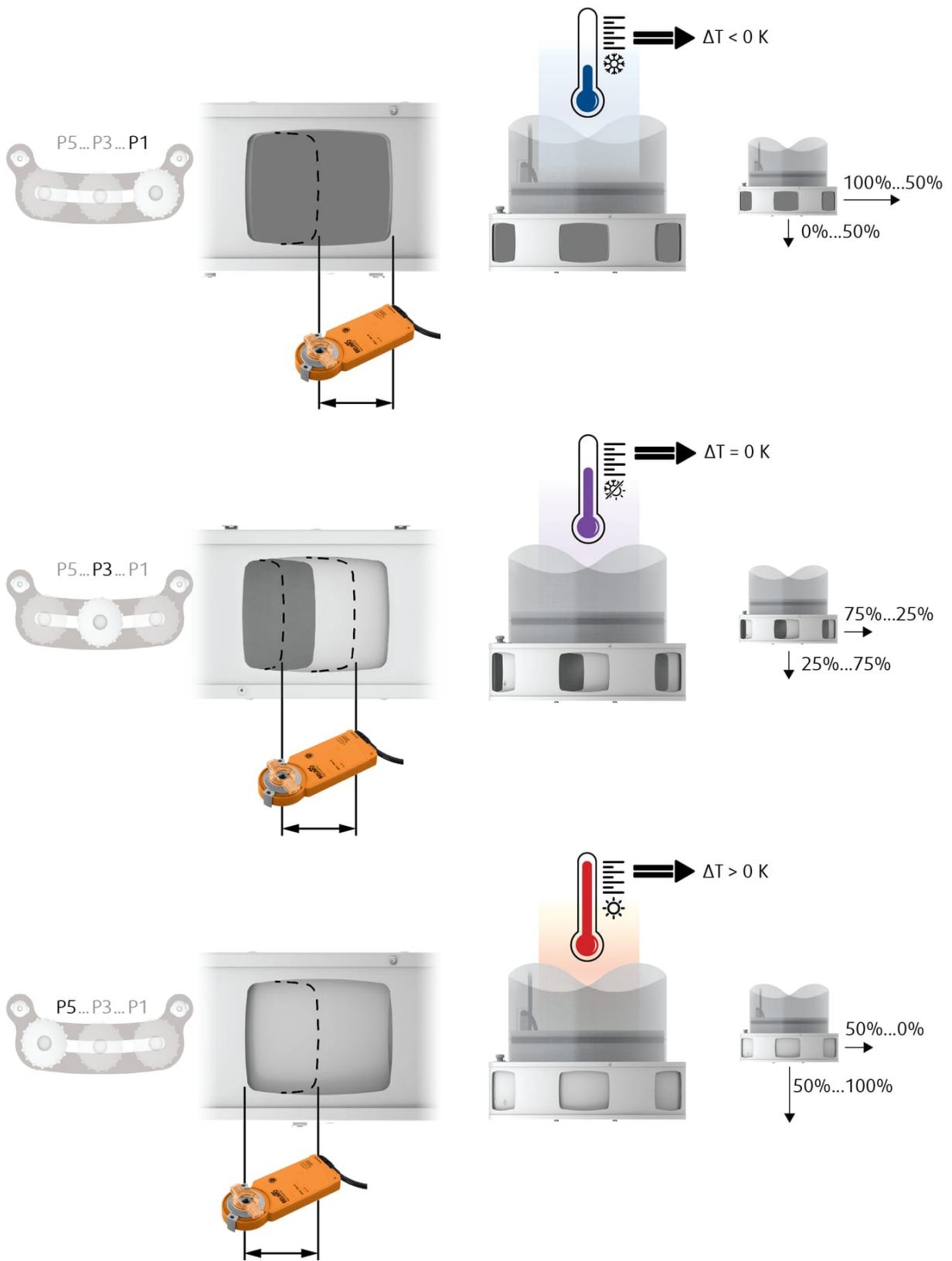

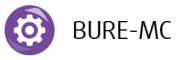

CM24-SR-F10
BURE-MC-250
BURE-MC-315



LH24A-MP100
BURE-MC-400



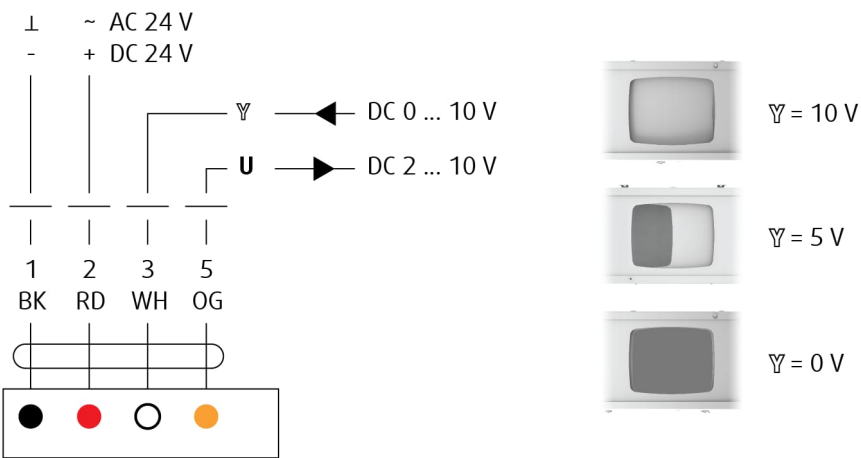

LH24A-MP200
BURE-MC-500
BURE-MC-630

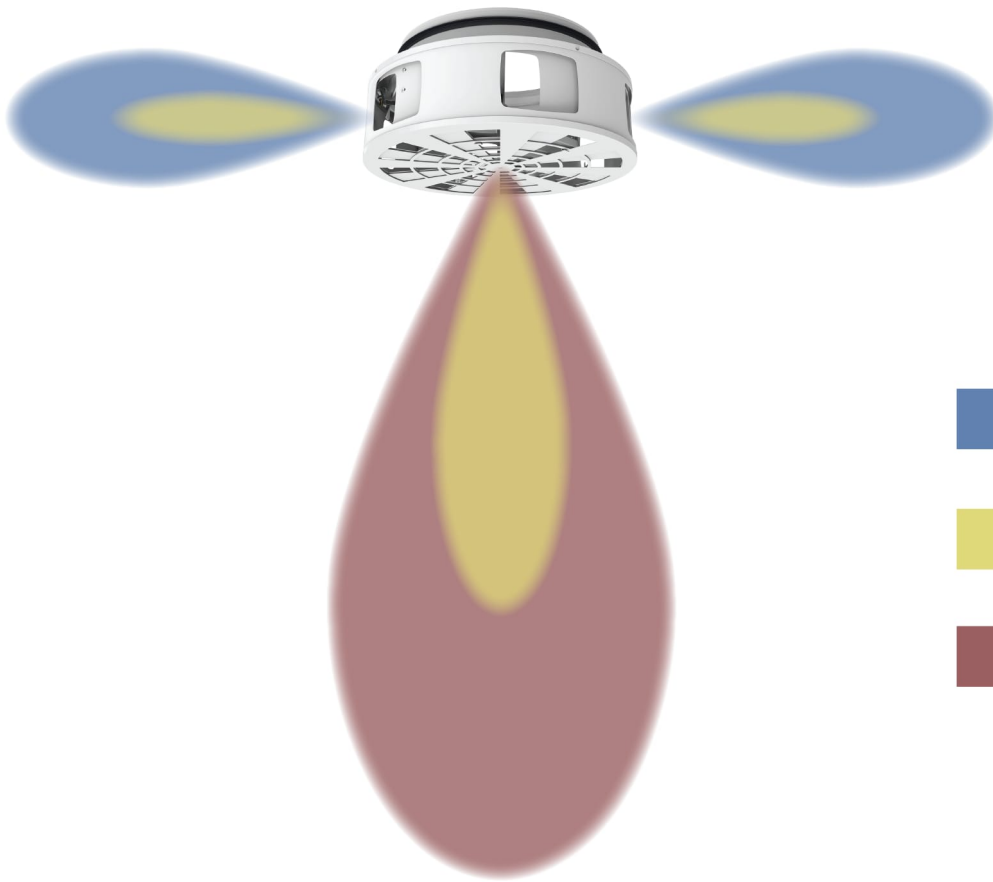
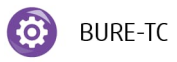



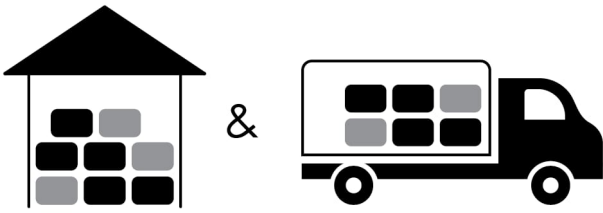

Transport, Storage and Operation



 °C -40 °C ... +50 °C

 % ≤ 95%



 °C -20 °C ... +50 °C

 % ≤ 95%

Supplement

Any deviations from the technical specifications contained herein and the terms should be discussed with the manufacturer. We reserve the right to make any changes to the product without prior notice, provided that these changes do not affect the quality of the product and the required parameters.

Current information on all products is available on design.systemair.com.

