

FDR-3G

Circular Fire Damper

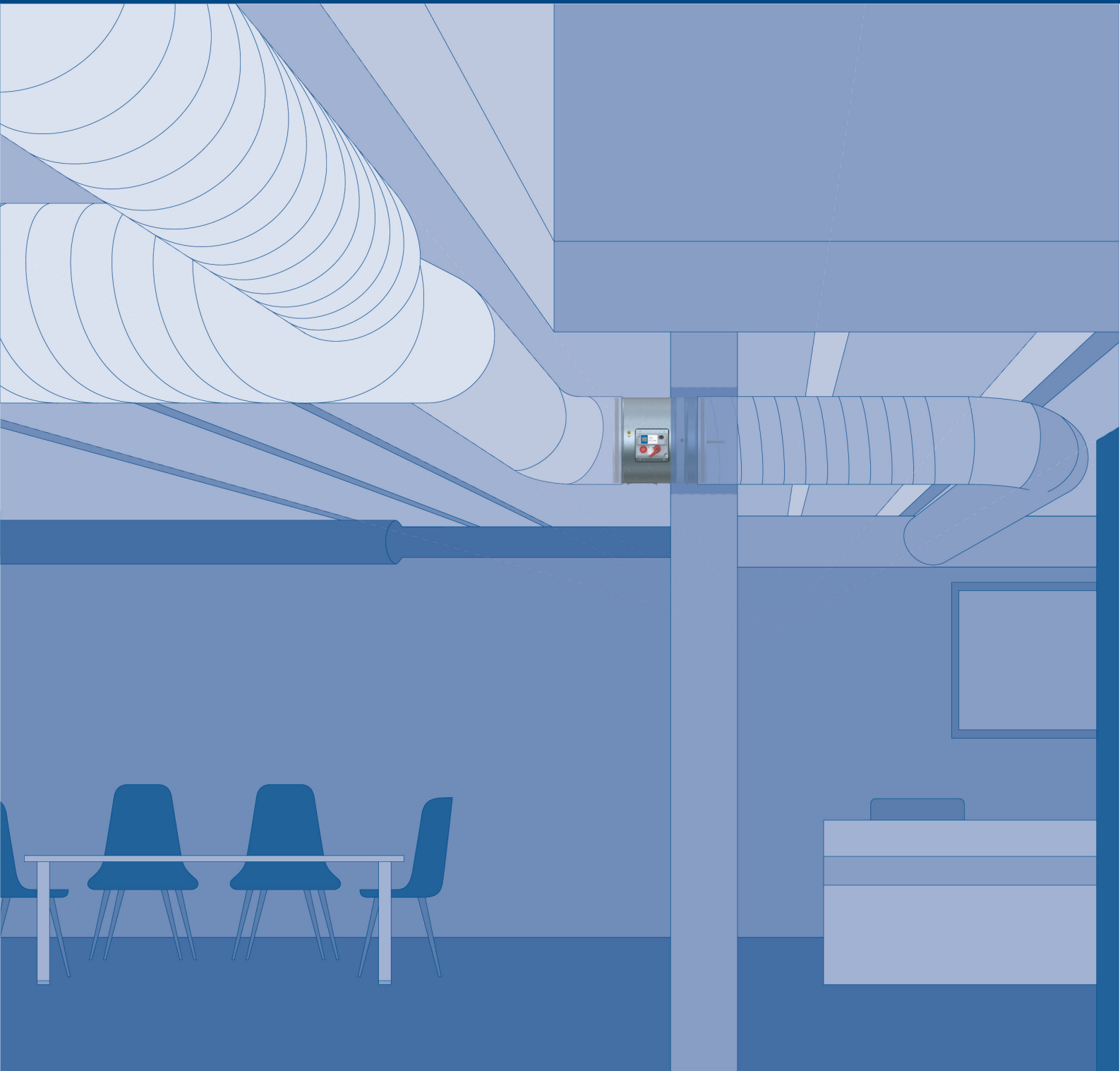

Table of Contents

<u>Overview</u>3
<u>Technical Parameters</u>5
<u>Diagrams</u>9
<u>Dimensions</u>11
<u>Ordering Code</u>13
<u>Installation</u>15
<u>Electrical parameters</u>41
<u>Operation manual</u>55

Circular Fire Damper FDR-3G



Description

Fire dampers represent passive fire protection, designed with the help of compartmentalization to prevent the spread of toxic gases, smoke and fire. Standard fire dampers are designed and certified in accordance with EN 15650 and tested for EIS criteria according to EN 1366-2. Fire damper together with its installation form an inseparable part of fire resistivity rating. FDR-3G fire dampers are designed for the installations listed and described in their User Manual. By default, all fire dampers are supplied with a manual mechanism or actuator mechanism, optionally with a supply and communication unit.

The activation mechanisms are removable and are interchangeable, for example an actuator operated mechanism instead of a manually operated mechanism.

Highlights

- Lightweight construction
- Tightness class 3C as standard
- Low pressure drop
- Changeable mechanism
- Inspection opening built-in
- Great variety of installations rated up to EI120S
- Modulated actuator suitable for system balancing - possibility to open the blade at the desired angle.

Activation Types

Manually Operated Fire Dampers

By default, all manually operated fire dampers are supplied with manual control, optionally with micro switches and electromagnets. In case of fire, the fire damper is closed automatically. Depending on the version, the damper closes either after the melting of the thermal fuse or by means of remote activation through an electromagnet in impulse connection. After the closing of the damper blade, it is mechanically locked in the closed position and can only be opened manually. The actuating mechanism is activated when the temperature of the air in the duct reaches 74°C and the damper closes within 10 seconds after the melting of the fuse.

- H0

Fire damper with an activation mechanism with a cover, manual crank and with a spring return release mechanism activated by a fusible thermal link set to 74°C (on demand 100°C).

- H2

Fire damper with an activation mechanism H0 + open and closed indication with AC 230 V or AC/DC 24 V contact switches.

- H5-2

Fire damper with an activation mechanism H0 + an AC/DC 24 V electromagnetic release mechanism in the impulse connection (release takes place when the electromagnet is activated) + open and closed indication with AC 230 V or AC/DC 24 V contact switches.

- H6-2

Fire damper with an activation mechanism H0 + an AC 230 V electromagnetic release mechanism in the impulse connection (release takes place when the electromagnet is activated) + open and closed indication with AC 230 V or AC/DC 24 V contact switches.

Actuator Operated Fire Dampers

By default, all actuator operated fire dampers are supplied with an actuator with micro switches, optionally with a power and communication unit. A fire damper can be equipped with a spring return actuator can be closed with command from the building management system, or after the breaching of the thermoelectric fuse. Actuator operated fire dampers are standardly equipped with a thermoelectric fuse, that activates the closing of the damper after the reaching or exceeding of the ambient temperature of 72°C. The actuator power circuit is interrupted and its spring closes the damper blade within 20 seconds.

Belimo actuator available with on demand fuse 95 °C or 120 °C.

- B230T or G230T

Fire damper with an activation mechanism with a Belimo or Gruner spring return actuator (AC 230 V) with electro-thermal fuse 72°C and auxiliary switches.

- B24T or G24T

Fire damper with an activation mechanism with a Belimo or Gruner spring return actuator (AC/DC 24 V) with electro-thermal fuse 72°C and auxiliary switches.

- BST0 or GST0

Fire damper with an activation mechanism with a Belimo or Gruner spring return actuator (AC/DC 24 V) with an electro-thermal fuse 72°C and auxiliary switches, with a Belimo supply and communication unit BKN230-24 or Gruner supply and communication unit fs-UFC24-2 (other communication units on demand).

- B24T-W or G24T-W

Fire damper with an activation mechanism with a Belimo or Gruner spring return actuator (AC/DC 24 V) with an electro-thermal fuse 72°C and auxiliary switches, with provided cable connectors for the supply and communication unit (communication unit not part of the mechanism).

- B24T-SR or G24T-SR

Fire damper with an activation mechanism with a Belimo or Gruner spring return actuator (AC/DC 24 V) with electro-thermal fuse 72°C and auxiliary switches for Modulated dampers (possibility to open the blade at the desired angle). For fire dampers in the size DN ≥ 160 mm.

Design

Fire dampers have casings made from galvanized sheet metal. Blades from non-asbestos insulants have a rubber seal for cold smoke and an intumescent seal, that expands in a fire situation.

Material Composition

The product contains galvanized sheet metal, calcium silicate board, fireproof carbon fiberglass, polyurethane foam and ethylene-propylene rubber. These are processed in accordance with local regulations. The product contains no hazardous substances, except for the solder in the thermofuse, which contains a milligram of lead.

List of Accessories

Detailed information about accessories for FDR-3G is available in SystemairDESIGN under Fire Damper Accessories.

- AM-FD: Activation Mechanisms
- CBR-FD: Cover Boards
- IPOR-FD: Insulation Cover Plates

Technical Parameters

Durability test

- 50 cycles/manually operated activation mechanism – with no change of the required properties
- 10000 + 100 + 100 cycles/actuator operated activation mechanism – with no change of the required properties

Fire testing pressure

Underpressure up to 300 Pa

Safety position

Closed. (In fire scenario the damper closes via spring in actuator or spring in manual mechanism)

Airflow direction

Both directions

Allowed air velocity

Damper can still operate at max. 12 m/s. Air without any mechanical or chemical contamination

Side with fire protection

Depending on installation classification: From both sides (i <-> o)

Repeated opening

Suitable for daily check procedure. It is not possible to operate the device after reaching Activation temperature.

Activation Temperature

- Manually operated: 74 °C as standard by means of a spring after the melting of the thermal fuse.
- Actuator operated: 72 °C as standard (95 °C or 120 °C on request with Belimo actuator) by means of the spring after current interruption in the electro-thermal fuse.

Operational temperature

- Minimum: 0 °C
- Maximum: 60 °C for 74 °C and 72 °C thermal fuse
- Maximum: 85 °C for 95 °C and 100 °C thermal fuse
- Maximum 105 °C for 120 °C thermal fuse

Environment suitability

Protected against weather disruptions, with temperature above 0 °C, up to 95% Rha, (3K5 according to EN 60721-3-3)

Open/Closed indication

- Manually operated microswitches - Activation types H2 up to H6-2
- Actuator operated built-in microswitches - Activation types B230T/G230T up to B24T-SR/G24T-SR

Closing/Opening time

Manually operated < 10 s, actuator operated < 20 s

Maintenance

Not required. Dry cleaning if demanded by law in the country in which the dampers are installed.

Revisions

Determined by law in the country in which the fire dampers are installed but at least every 12 months.

Allowed pressure

1200 Pa

Blade tightness (STN EN 1751)

Class 3 as standard

Tightness of the housing (STN EN 1751)

Class C as standard

Conformity with EC directives

2006/42/EC Machinery Directive

2014/35/EU Low Voltage Directive

2014/30/EU Electromagnetic Compatibility Directive

Driving actuator types

Belimo: BLF230-T, BLF24-T, BFL24-SR-T, BF230-T, BF24-T, BF24-SR-T, BFN230-T, BFN24-T, BFN24-T, BFL230-T, BFL24-T, BFL24-SR-T (also with connection possibilities with acronyms ST, W)

Gruner: 360TA-230-12-S2, 360CTA-024-12-S2, 360TA-024-12-S2, 340TA-230D-03-S2, 340TA-024D-03-S2, 340CTA-024D-03-S2, 340TA-230-05-S2, 340TA-024-05-S2, 340CTA-024-05-S2 (also with connection possibilities with acronyms ST, W)

Transport and Storage

Dry indoor conditions with a temperature range of -20 °C to +50 °C

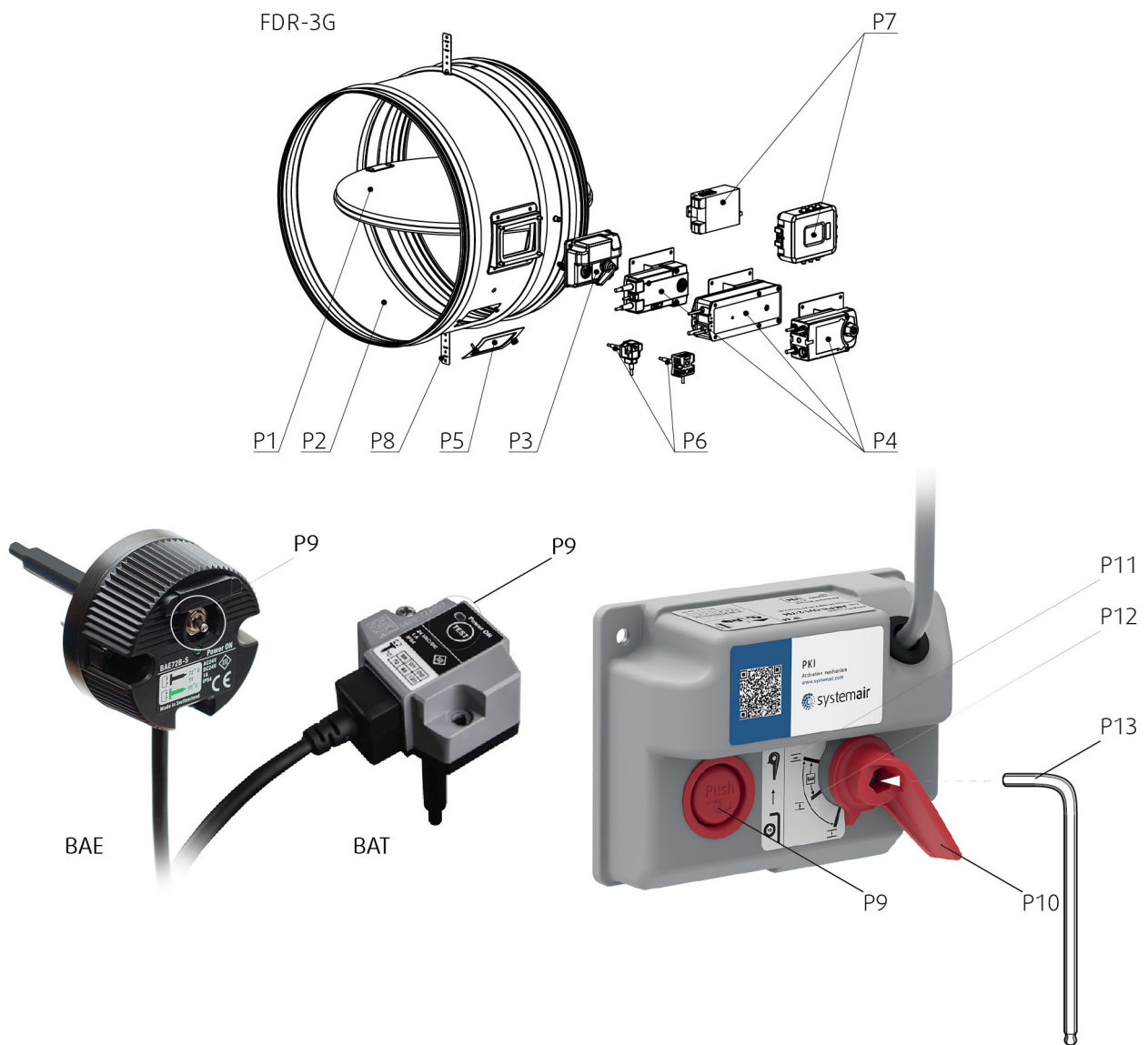

Legend:

- P1** Blade
- P2** Casing
- P3** Manually operated activation mechanism (H0;H...)
- P4** Actuator operated activation mechanism (B...;G...)
- P5** Inspection lid
- P6** Thermoelectric fuse (BAT72;TA-72)
- P7** Supply and communication unit (BKN230-24;FS-UFC24-2)
- P9** Release and test button
- P10** Crank
- P11** Open position
- P12** Closed position
- P13** Hexagon bent wrench No.10 (not part of delivery)

Assessed Performance - FDR-3G

19 CE 1396

Systemair Production a.s.

Hlavná 371, 900 43 Kalinkovo, Slovakia

1396-CPR-0162, FDR-3G

(valid for subgroups: ...EX, ...KS, ...OF)

EN 15650 : 2010

Circular fire dampers

Nominal activation conditions/sensitivity - **Pass**

- sensing element load bearing capacity
- sensing element response temperature

Response delay (response time) - **Pass**

- closure time

Operational reliability - **Pass**

- motorized cycle = 10.200 cycles
- manual cycle = 50 cycles
- modulated = 20.200 cycles

Fire resistance:

Resistivity depending on installation method and situation

- integrity **E**
- maintenance of the cross section (under E)
- mechanical stability (under E)
- cross section (under E)
- insulation **I**
- smoke leakage **S**

Durability of response delay - **Pass**

- sensing element response temperature and load bearing capacity

Durability of operational reliability - **Pass**

- open and closing cycle

Diagrams

FDR-3G-...-H0

Pressure drop & sound power level (A-weighted)

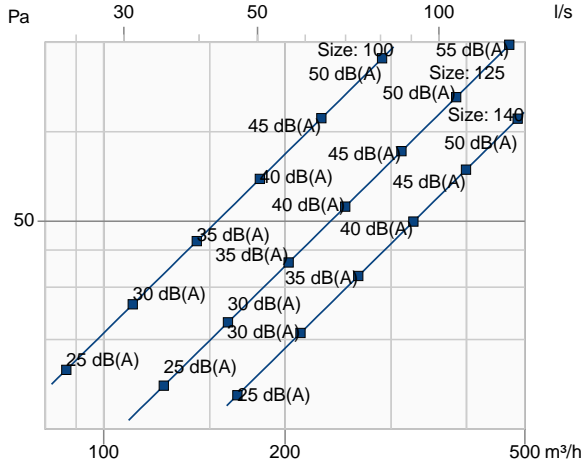

FDR-3G-...-H0

Pressure drop & sound power level (A-weighted)

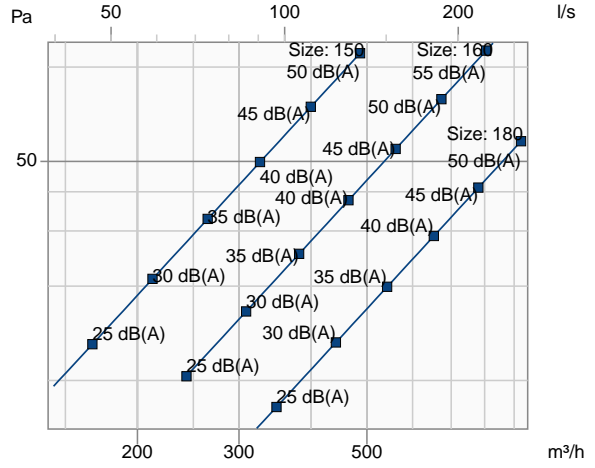

FDR-3G-...-H0

Pressure drop & sound power level (A-weighted)

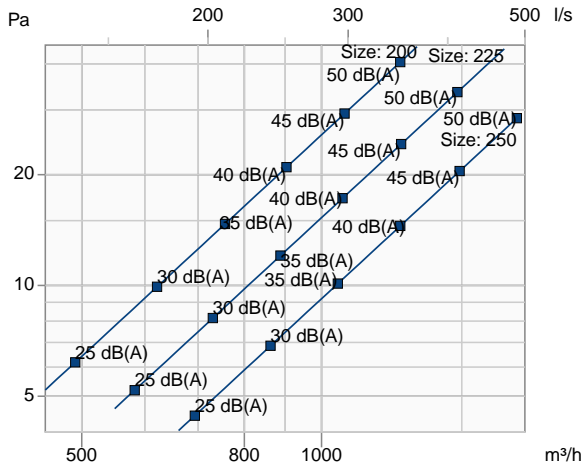

FDR-3G-...-H0

Pressure drop & sound power level (A-weighted)

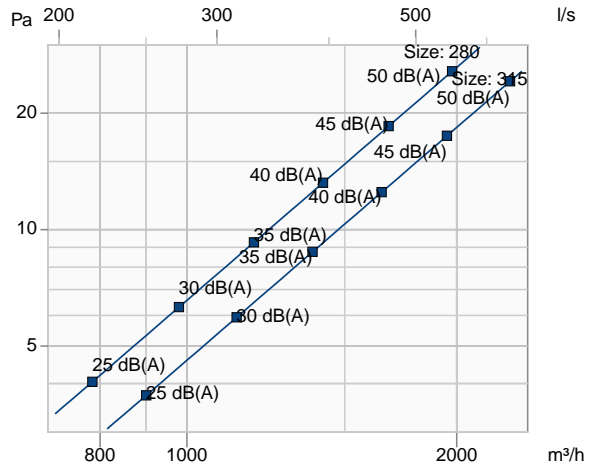

FDR-3G-...-H0

Pressure drop & sound power level (A-weighted)

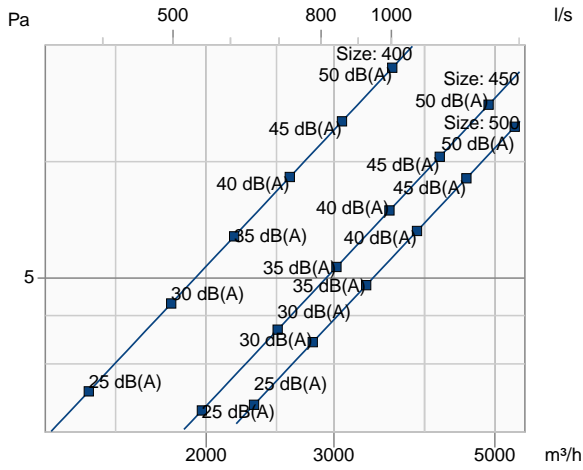

FDR-3G-...-H0

Pressure drop & sound power level (A-weighted)

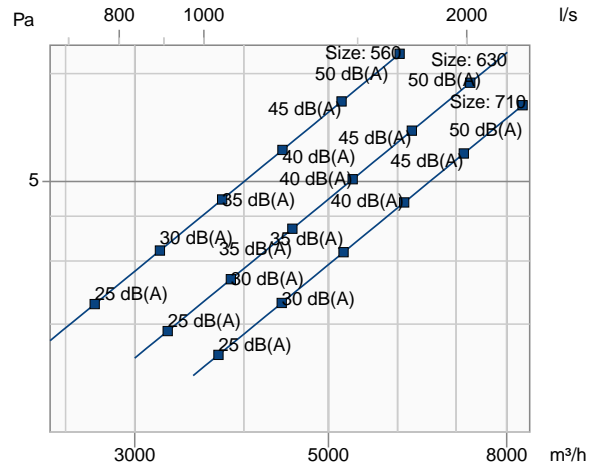

FDR-3G-...-H0

Pressure drop & sound power level (A-weighted)

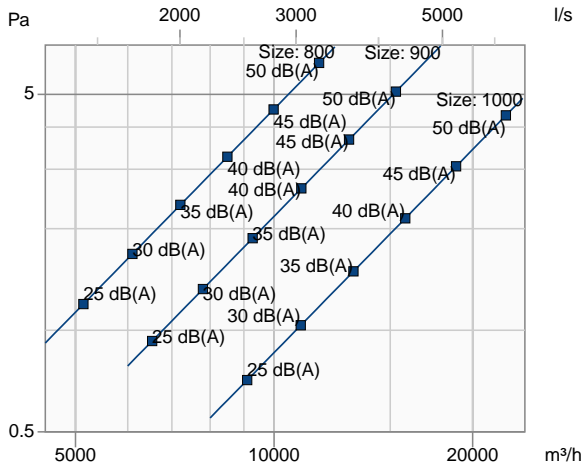

Dimensions

DN 100 up to DN 630

Free area

A _v (m ²)	DN (mm)																
	100	125	140	150	160	180	200	225	250	280	315	355	400	450	500	560	630
	0,003	0,007	0,009	0,011	0,013	0,018	0,023	0,031	0,039	0,050	0,065	0,085	0,110	0,138	0,173	0,220	0,283

Dimensions

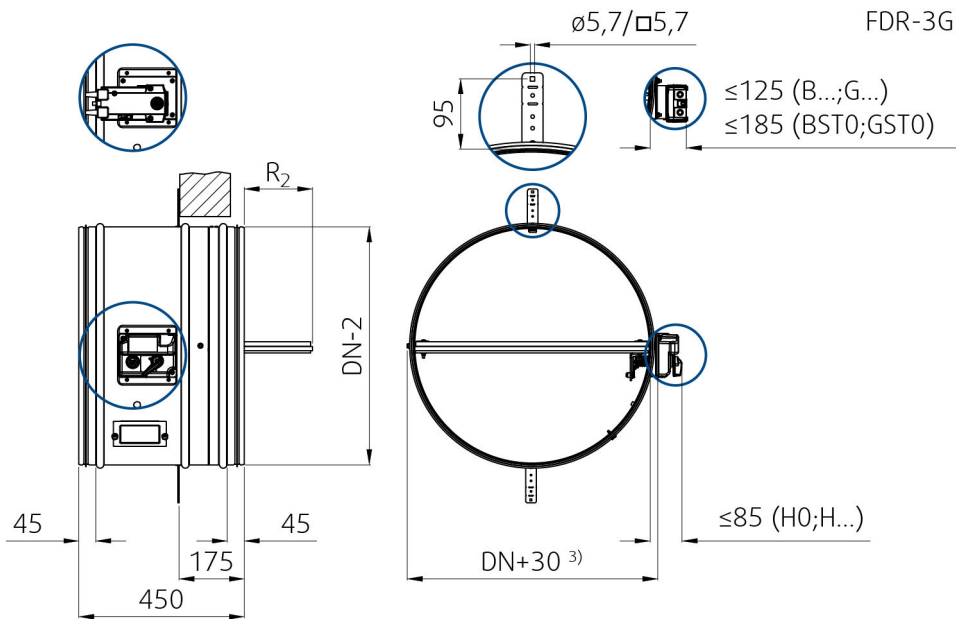

Note: 3) Inclusive bearing

Overhangs

	DN (mm)																
	100	125	140	150	160	180	200	225	250	280	315	355	400	450	500	560	630
R ₁ (mm)	-300	-287,5	-280	-275	-270	-260	-250	-237,5	-225	-210	-192,5	-172,5	-150	-125	-100	-70	-35
R ₂ (mm)	-67	-54,5	-47	-42	-37	-27	-17	-4,5	8	23	40,5	60,5	83	108	133	163	198

Weights

m (kg ±5%)	DN (mm)																
	100	125	140	150	160	180	200	225	250	280	315	355	400	450	500	560	630
H0, H...	3,3	3,4	3,6	3,7	3,8	4,2	4,4	4,8	5,3	5,8	6,4	7,3	8,3	11,1	12,3	14,6	17,0
B..., G...	4,8	4,9	5,1	5,2	5,3	5,7	5,9	6,3	6,8	7,3	7,9	8,8	9,8	11,9	13,1	15,4	17,8

Ordering Code

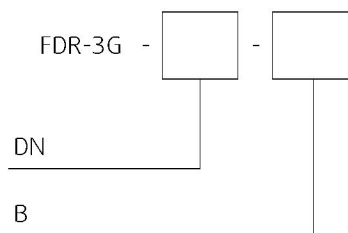

DN

Dimension, \varnothing DN (from 100 mm up to 1000 mm)

B - Type of Activation (H0 up to B24T-SR)

H0 (Manual crank, no switches)

H2 (Manual crank, 2 switches 230V AC or 24V AC/DC)

H5-2 (Manual crank, 24V AC/DC electromagnet, 2 switches 230V AC or 24V AC/DC)

H6-2 (Manual crank, 230V AC electromagnet, 2 switches 230V AC or 24V AC/DC)

B230T (230V AC Belimo Actuator)

G230T (230V AC Gruner Actuator)

B24T (24V AC/DC Belimo Actuator)

G24T (24V AC/DC Gruner Actuator)

BST0 (230V AC Supply comm.unit & 24V AC/DC Belimo Actuator)

GST0 (24V AC/DC Supply comm.unit & 24V AC/DC Gruner Actuator)

B24T-W (24V AC/DC Belimo Actuator & Wire connector for comm.unit)

G24T-W (24V AC/DC Gruner Actuator & Wire connector for comm.unit)

Only for dimensions (from 200 mm up to 1000 mm)

B24T-SR (24V AC/DC Belimo Actuator, modulated 0..10 V)

G24T-SR (24V AC/DC Gruner Actuator, modulated 0..10 V)

Example of the Circular Fire Dampers Ordering Code

FDR-3G-1000-H5-2

Circular fire damper, nominal diameter 1000 mm, manually operated activation mechanism with open and closed position indication with 230 V contact microswitches.

Note: The fire resistivity depends on the installation method.

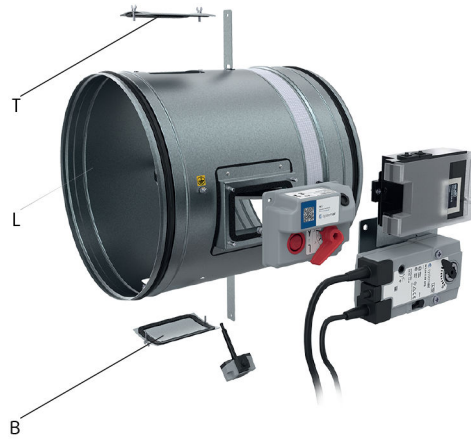

Inspection opening positions (Removable mechanism is available for all sizes):

$DN \leq \varnothing 150$

No inspection opening. Inspection possible through removable mechanism or additional inspection opening must be added to the connecting duct.













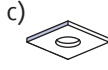



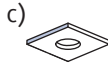







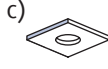



$\varnothing 160 \leq DN \leq \varnothing 225$

Standardly in position: L; Additional inspection opening cannot be added.

$\varnothing 250 \leq DN \leq \varnothing 1000$

Standardly in position: B; On demand in position: L, T.

Installation Methods

 1 Wet	FDR-3G DN100 ... DN1000	EI 60 ($v_e h_o i \leftrightarrow o$) S				 360°
		EI 90 ($v_e h_o i \leftrightarrow o$) S				
		EI 120 ($v_e h_o i \leftrightarrow o$) S				
 2 Dry	FDR-3G DN100 ... DN630	EI 60 ($v_e h_o i \leftrightarrow o$) S				 360°
		EI 90 ($v_e h_o i \leftrightarrow o$) S				
 2 Dry	FDR-3G > DN630 ... DN1000	EI 60 ($v_e - i \leftrightarrow o$) S			 360°	
		EI 90 ($v_e - i \leftrightarrow o$) S				
 3 Soft	FDR-3G DN100 ... DN630	EI 60 ($v_e h_o i \leftrightarrow o$) S				 360°
		EI 90 ($v_e h_o i \leftrightarrow o$) S				
 3H Hilti	FDR-3G DN100 ... DN630	EI 60 ($v_e - i \leftrightarrow o$) S			 360°	
		EI 90 ($v_e - i \leftrightarrow o$) S				
 5.1 On, Out	FDR-3G DN100 ... DN400	EI 60 ($v_e - i \leftrightarrow o$) S				
		EI 90 ($v_e - i \leftrightarrow o$) S				
 5.2 On, Out	FDR-3G DN100 ... DN500	EI 60 ($v_e - i \leftrightarrow o$) S				

Legend:

1. **Wet** - Wet Installation, Using Plaster/Mortar/Concrete Filling
2. **Dry** - Dry Installation, using cover boards and mineral wool filing
3. **Soft** - Soft Installation, using mineral wool filing
- 3H. **Hilti** - Filling made only from Hilti foam
- 5.1. **On & Out** - ON & OUT of the wall installation rated for EI90S, Using 2 layers of Mineral Wool
- 5.2. **On & Out** - ON & OUT of the wall installation rated for EI60S, Using 1 layer of Mineral Wool

- a) - Flexible (plasterboard) wall
- b) - Concrete/masonry/cellular concrete (rigid) wall
- c) - Concrete/cellular concrete (rigid) floor/ceiling
- v_e - Vertical wall
- h_o - Horizontal floor/ceiling

Installation, Maintenance & Operation

Some damper parts may have sharp edges – therefore to protect yourself from harm, please use gloves during damper installation and manipulation. In order to prevent electric shock, fire or any other damage which could result from incorrect damper usage and operation, it is important to:

1. ensure that installation is performed by a trained person.
2. follow the written and depicted instructions provided within Handbook closely.
3. perform damper inspection in accordance with Handbook.
4. check the damper's functionality as per the chapter "Fire Damper Functionality Check" before you install the fire damper. This procedure prevents the installation of a damper that has been damaged during transportation or handling.

Information about installation, maintenance and operation is available in the "Handbook_FDR-3G" document or more can be found at design.systemair.com.

Installation rules

- The duct connected to the fire damper must be supported or hung in such a way that the damper does not carry its weight. The damper must not support any part of the surrounding construction or wall which could cause damage and consequent damper failure. It is recommended to connect the damper to a dilatation compensator on either end of the damper.
- The damper driving mechanism can be placed on either side of the wall, however it needs to be placed so as to ensure easy access during inspection.
- According to the standard EN 1366-2, the distance between the fire damper bodies must be at least 200 mm. This condition does not apply for tested distances. Therefore installations Wet and Soft are approved for smaller distances under condition that the resulted resistivity is reduced to EI90S.
- The distance between the wall/ceiling and the fire damper must be at least 75 mm. This condition does not apply for tested distances. Therefore installations Wet and Soft are approved for smaller distances under condition that the resulted resistivity is reduced to EI90S.
- The fire damper must be installed into a fire partition structure in such a way that the damper blade in its closed position is located inside this structure. A bendable hinge is provided on the damper body which represents a plane where supporting construction begins. This condition does not apply for installations On & Out.
- For each resistivity the minimum thickness of a its supporting construction cannot be decreased as per EN 1366-2 at least 200 mm from the installation opening.
- The gap in the installation opening between the fire damper and the wall/ceiling can be increased by up to 50% of the gap area, or decreased to the smallest amount possible that still provides sufficient space for the installation of the filling.

IN ACCORDANCE WITH EN 15650, EACH FIRE DAMPER MUST BE INSTALLED ACCORDING TO THE INSTALLATION INSTRUCTIONS PROVIDED BY THE MANUFACTURER!

Wet Installation

Using Plaster/Mortar/Concrete Filling

1. The supporting construction opening must be prepared as depicted. Opening surfaces must be even and cleaned off. The flexible wall opening must be reinforced as per the standards for plasterboard walls. The opening dimensions are driven by the nominal dimensions of the damper with added clearance. For circular dampers prepare the opening of diameter D1.
2. Insert the closed damper into the middle of the opening so that the damper blade is in the wall. Use the bendable hanger (2; or hangers) to secure the damper against the wall using a suitable screw (F1; recommended screw diameter 5,5; e.g. DIN7981).
- 3.

For damper diameter greater than 800 mm, it is recommended to use a duct support inside the damper to avoid any damage, bend to the damper housing from the weight of the filling.

4. Fill in the area between the wall and the damper with plaster or mortar or concrete filling (2), while paying attention to prevent the fouling of the damper's functional parts, which could limit its correct functionality. The best way is to cover the functional parts during installation. The seepage of the filling material can be prevented by using boards. However, these are not required for wet installation.

First let the plaster or mortar or concrete filling harden and then perform the next steps!

5. After the filling hardens, remove the duct support from inside of the damper.
6. If needed, uncover and clean the damper after installation.
7. Check the damper's functionality

Installation - Standard Distances





According to the standard EN 1366-2, the minimum distance from the wall or ceiling to the damper body is 75 mm. For multiple crossings through a fire-resistive wall the minimum distance between two damper bodies is 200 mm. This applies to distances between the damper and a nearby foreign object crossing the fire-resistive wall.

Installation - Smaller Distances - Maximum resistivity reduced to EI90S

The distance between 2 individual fire dampers can be reduced to 60 mm, measured from surface to surface of the housing and the distance between the surface of the damper installed in the duct and the adjacent supporting construction (wall/floor) can be reduced to 40 mm, provided that the fire resistance classification will be reduced as follows: EI90 (ve i <-> o) S.

Installation in a Wall thinner than tested

Installation in a thinner wall is allowed under the condition that an additional layer/layers of fire protective board are fixed to the surface of the wall in order to achieve the same length of damper penetration seal as was tested. The minimum width of added boards around the damper is 200 mm. In addition, the alternative thinner wall should be classified in accordance with EN 13501-2:2007 + A1: 2009 for fire-resistance required for product application. For a protruding wall, the additional layers must be fixed on the steel supporting construction of the wall.

 1 Wet	FDR-3G DN100 ... DN1000	EI 60 (v _e h _o i ↔ o) S				 360°
		EI 90 (v _e h _o i ↔ o) S				
		EI 120 (v _e h _o i ↔ o) S				

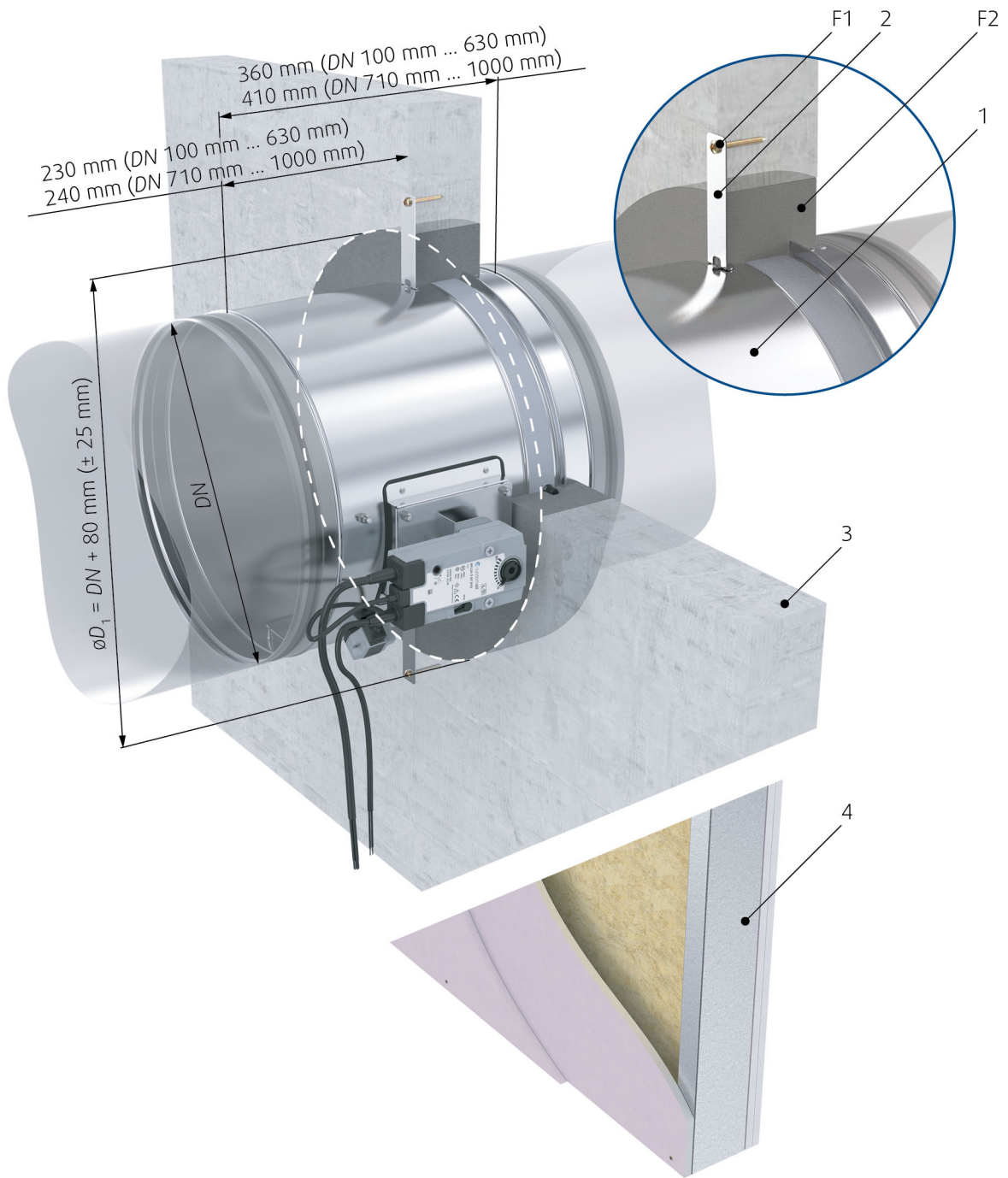

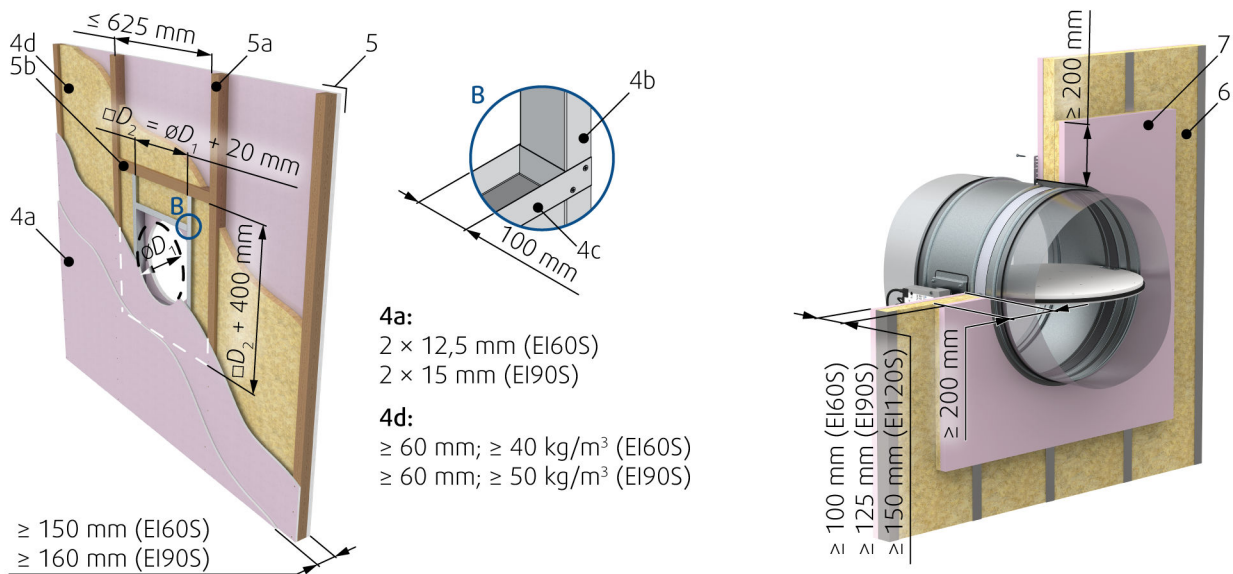
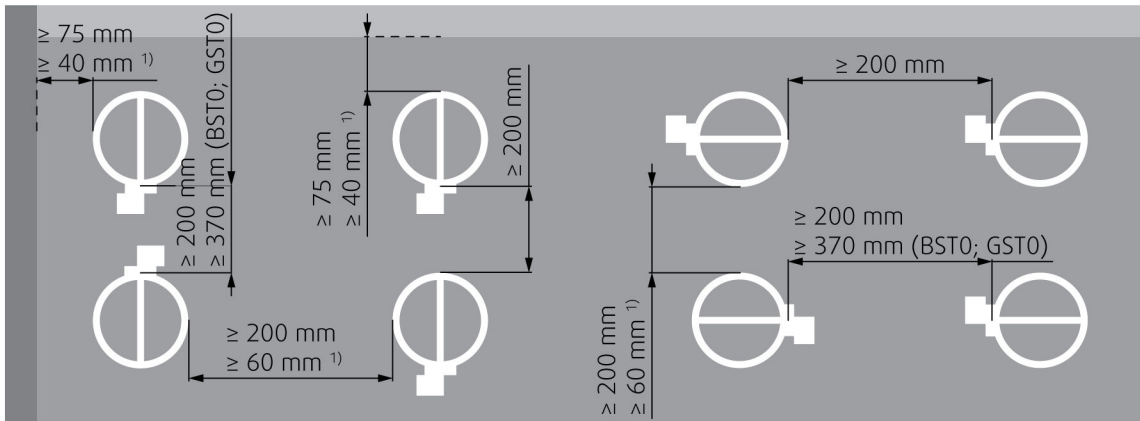
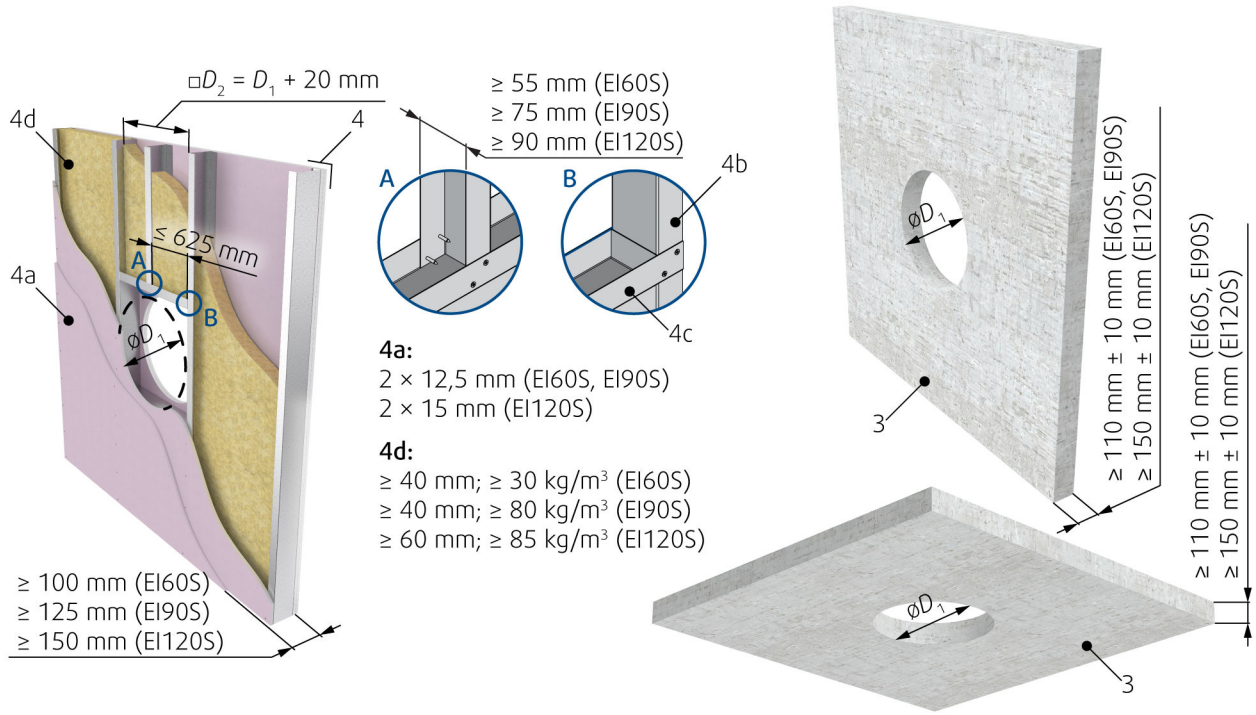

Legend

F1 Screw $\geq 5,5$ DIN7981 or suitable wall plug and screw size 6.

F2 Plaster/mortar/concrete filling

1 Fire damper (actuator side)

2 Bendable hanger

3 Concrete/masonry/cellular concrete wall or ceiling

4 Flexible (plasterboard) wall

4a 2 layers of plasterboard fireproof plate type F, EN 520

4b Vertical CW – profiles

4c Horizontal CW – profiles

4d Mineral wool; thickness/cubic density see picture.

5 Flexible (wood beam) wall

5a Vertical spruce wooden beam $\geq 60 \times 100$ mm

5b Horizontal spruce wooden beam $\geq 80 \times 100$ mm

6

Alternative thinner wall (classified in accordance with EN 13501-2:2007 + A1: 2009 for fire resistance required for product application)

7

Area of 200 mm from opening around the damper must have the same composition and be created the same way as Flexible (plasterboard) wall.

Notes:

ve Vertical (wall)

ho Horizontal (floor/ceiling)

1) Smaller distances – resistivity must be reduced to EI90 (ve i<->o) S

Dry Installation

Using Mineral Wool and Cover Boards









1. The supporting construction opening must be prepared as depicted. Opening surfaces must be even and cleaned off. The flexible wall opening must be reinforced as per the standards for plasterboard walls. The opening dimensions are driven by the nominal dimensions of the damper with added clearance. For circular dampers prepare the opening of diameter D1.
2. With these dampers it is necessary to install the bendable hangers (2) onto the cover boards using suitable screws or screws with wall plug (F1). Therefore, it is necessary to begin by installing the bottom part/parts of the CBR-FD or CBS-FD cover boards. Insert the damper from the mechanism side and secure the bendable hangers of the damper into the cover plate using suitable screws (F1). Subsequently mount the remaining cover boards from the mechanism side.
3. Fill in the area between the wall and the damper with mineral wool (F3) with a density of at least 50 kg/m³ thoroughly but in such a way that will not deform the damper housing, while paying attention to prevent the fouling of the damper's functional parts, which could limit its correct functionality.
4. Close the gap between the damper and the mounting opening, for a circular damper use CBR-FD cover boards, for a rectangular damper use CBS-FD cover boards with screws (F1) through pre-drilled holes.
5. All the gaps between the cover boards, between cover boards and the wall and between cover boards and the fire damper need to be filled with fire-resistive coating (F4).
6. If needed, uncover and clean the damper after installation.
7. Check the damper's functionality

Installation- Standard Distances

For Dry installation, the minimum distance from the wall or ceiling to the damper body is 100 mm and for DN>560 the distance is 150 mm. For multiple crossings through a fire-resistive wall the minimum distance between two damper bodies is 200 mm and for DN>560 the minimum distance is 300 mm. This applies for distances between the damper and a nearby foreign object crossing the fire-resistive wall.

Installation in a Wall thinner than tested

Installation in a thinner wall is allowed under the condition that an additional layer/ layers of fire protective board are fixed to the surface of the wall in order to achieve the same length of damper penetration seal as was tested. The minimum width of added boards around the damper is 200 mm. In addition, the alternative thinner wall should be classified in accordance with EN 13501-2:2007 + A1: 2009 for fire resistance required for product application. For a protruding wall, the additional layers must be fixed on the steel supporting construction of the wall.

 2 Dry	FDR-3G DN100 ... DN630	EI 60 (v _e h _o i ↔ o) S	a) 	b) 	c) 	 360°
		EI 90 (v _e h _o i ↔ o) S				
 2 Dry	FDR-3G > DN630 ... DN1000	EI 60 (v _e - i ↔ o) S	a) 	b) 	 360°	
		EI 90 (v _e - i ↔ o) S				

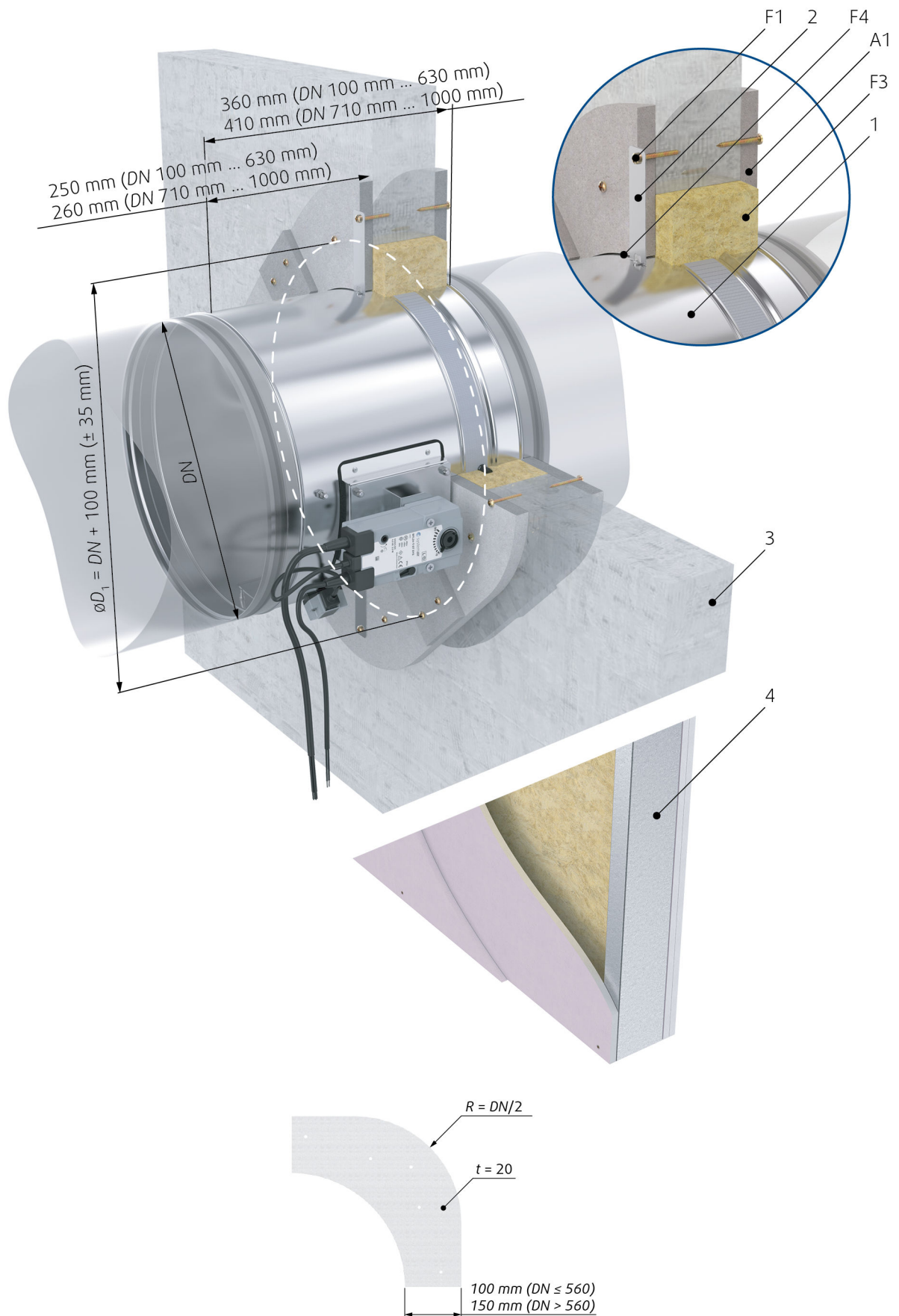

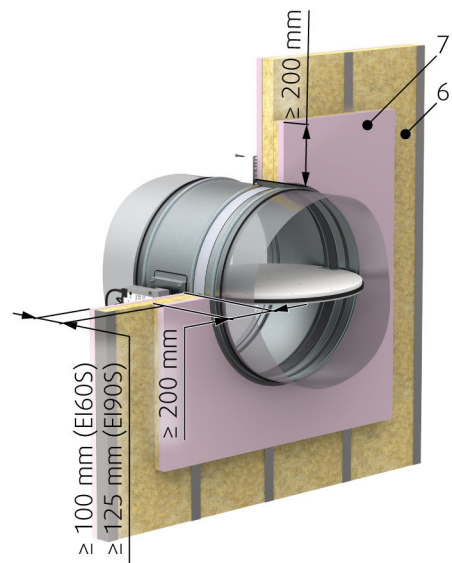
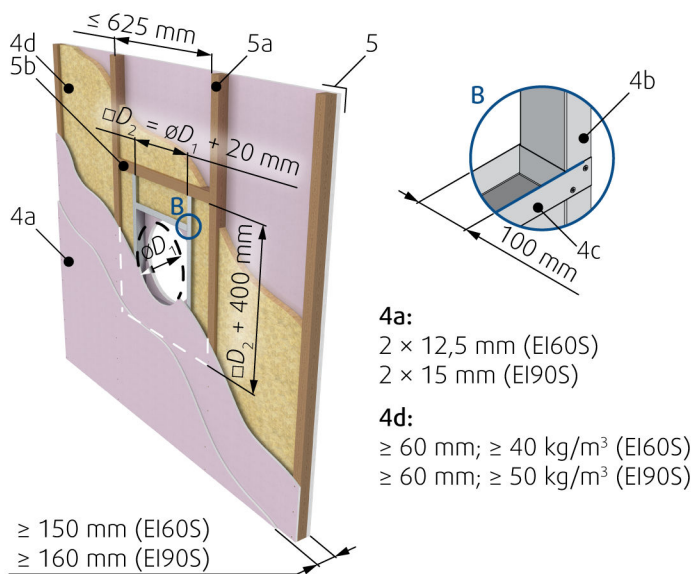
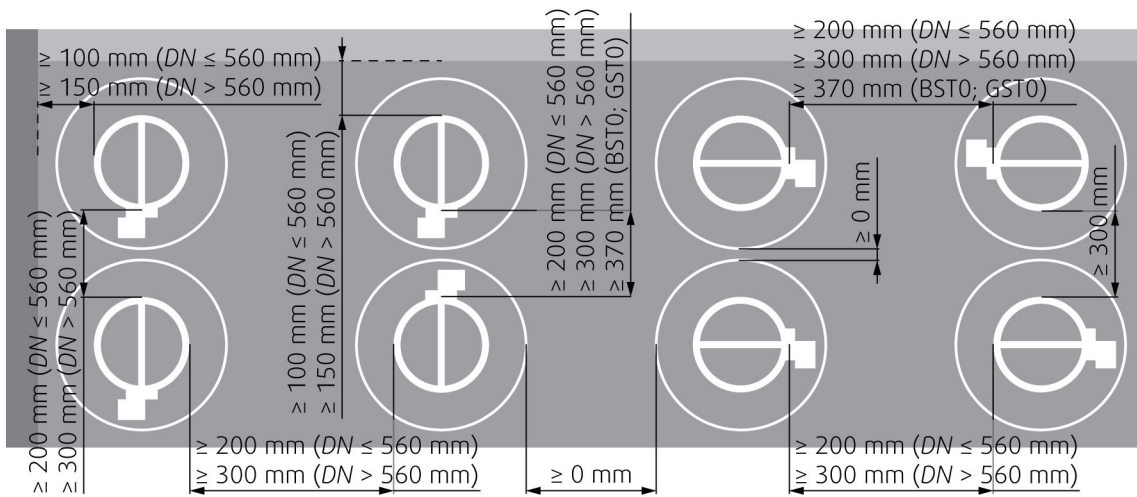
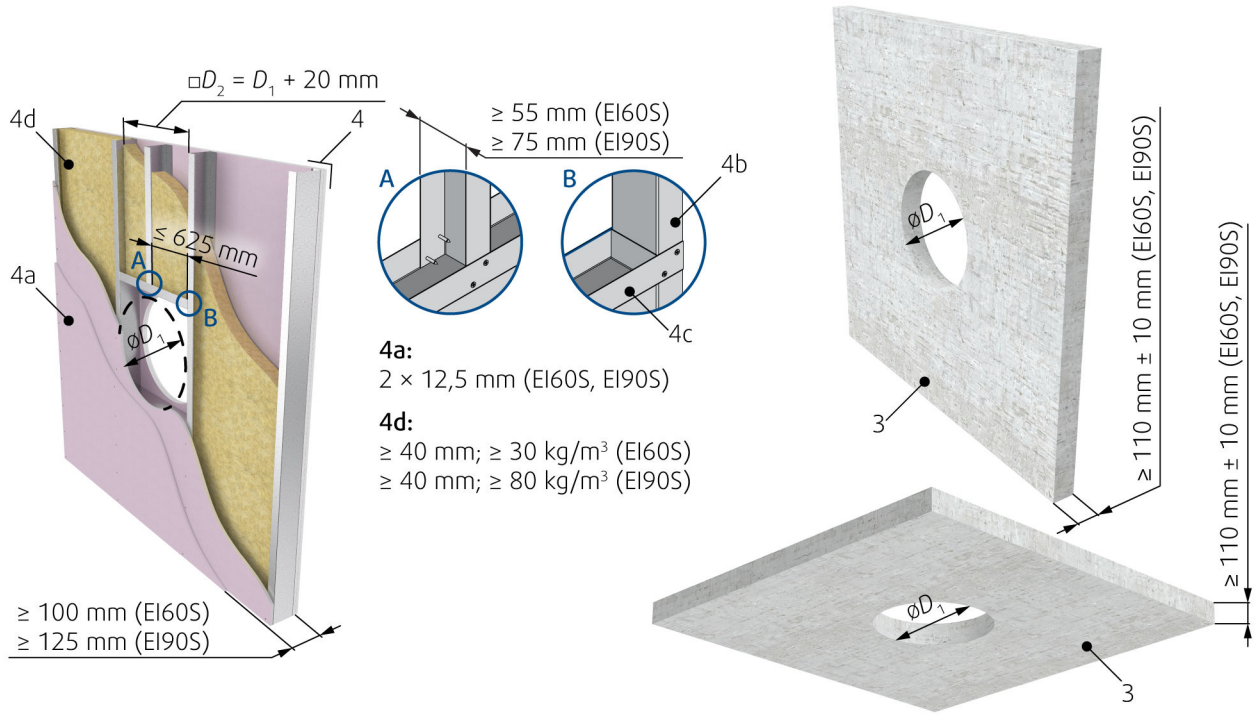

Legend

F1 Screw $\geq 5,5$ DIN7981 or suitable wall plug and screw size 6.

F3 Mineral wool filling (min. 50 kg/m³)

F4 Fire resistive coating, e.g. Promastop-CC/Promat

A1 Cover board CBR-FD (accessory) obligatory

1 Fire damper (actuator side)

2 Bendable hanger

3 Concrete/masonry/cellular concrete wall or ceiling

4 Flexible (plasterboard) wall

4a 2 layers of plasterboard fireproof plate type F, EN 520

4b Vertical CW – profiles

4c Horizontal CW – profiles

4d Mineral wool; thickness/cubic density see picture.

5 Flexible (wood beam) wall

5a Vertical spruce wooden beam $\geq 60 \times 100$ mm

5b Horizontal spruce wooden beam $\geq 80 \times 100$ mm

6

Alternative thinner wall (classified in accordance with EN 13501-2:2007 + A1: 2009 for fire resistance required for product application)

7

Area of 200 mm from opening around the damper must have the same composition and be created the same way as Flexible (plasterboard) wall.

Notes:

ve Vertical (wall)

ho Horizontal (floor/ceiling)

Soft installation

Installation in a Soft Crossing with fire-resistive coating

With this installation we recommend using flexible connection (see accessory FCR) due thermal expansion of connected ducts during fire. Install the compensator so, that the flexible part has a minimum distance of 50 mm from the edge of a damper's blade in open position.

1. The supporting construction opening must be prepared as depicted. Opening surfaces must be even and cleaned off. The flexible wall opening must be reinforced as per the standards for plasterboard walls. The opening dimensions are driven by the nominal dimensions of the damper with added clearance. For circular dampers prepare the opening of diameter D1.
2. Prepare mineral wool installation segments with thickness of the opening height (F5). First apply a suitable fire-resistive coating (F6) onto the damper at the place of its future placement, assemble and glue the filling of the future installation with the same fire-resistive coating. After the fire-resistive coating has dried the damper along with the filling are ready for installation.
3. Apply the same fire-resistive coating (F6) onto the internal surface of the wall opening. Also apply the fire-resistive coating on the external surface of the filling glued on the damper surface. Immediately after the fire-resistive coating is applied, place the damper into the wall opening. The damper blade must be located in the supporting structure.
4. After inserting the damper into the opening and fixing it using the bendable hangers and suitable screws (F1), apply the same fire-resistive coating (F6), at least 2 mm thick and 100 mm wide, on the exposed filling and wall edges evenly from both sides. Do not apply this layer in the place where the mechanism is located, inspection openings and manufacturer labels.
5. If needed, uncover and clean the damper after installation.
6. Check the damper's functionality

Installation - Standard Distances





According to the standard EN 1366-2, the minimum distance from the wall or ceiling to the damper body is 75 mm. For multiple crossings through a fire-resistive wall the minimum distance between two damper bodies is 200 mm. This applies to distances between the damper and a nearby foreign object crossing the fire-resistive wall.

Installation - Smaller Distances

The distance between 2 individual fire dampers can be reduced to 60 mm, measured from surface to surface of the housing and the distance between the surface of the damper installed in the duct and the adjacent supporting construction (wall/floor) can be reduced to 40 mm.

Installation in a Wall thinner than tested

Installation in a thinner wall is allowed under the condition that an additional layer/layers of fire protective board are fixed to the surface of the wall in order to achieve the same length of damper penetration seal as was tested. The minimum width of added boards around the damper is 200 mm. In addition, the alternative thinner wall should be classified in accordance with EN 13501-2:2007 + A1: 2009 for fire resistance required for product application. For a protruding wall, the additional layers must be fixed on the steel supporting construction of the wall.

 3 Soft	FDR-3G DN100 ... DN630	El 60 ($v_e h_o i \leftrightarrow o$) S				 360°
		El 90 ($v_e h_o i \leftrightarrow o$) S				

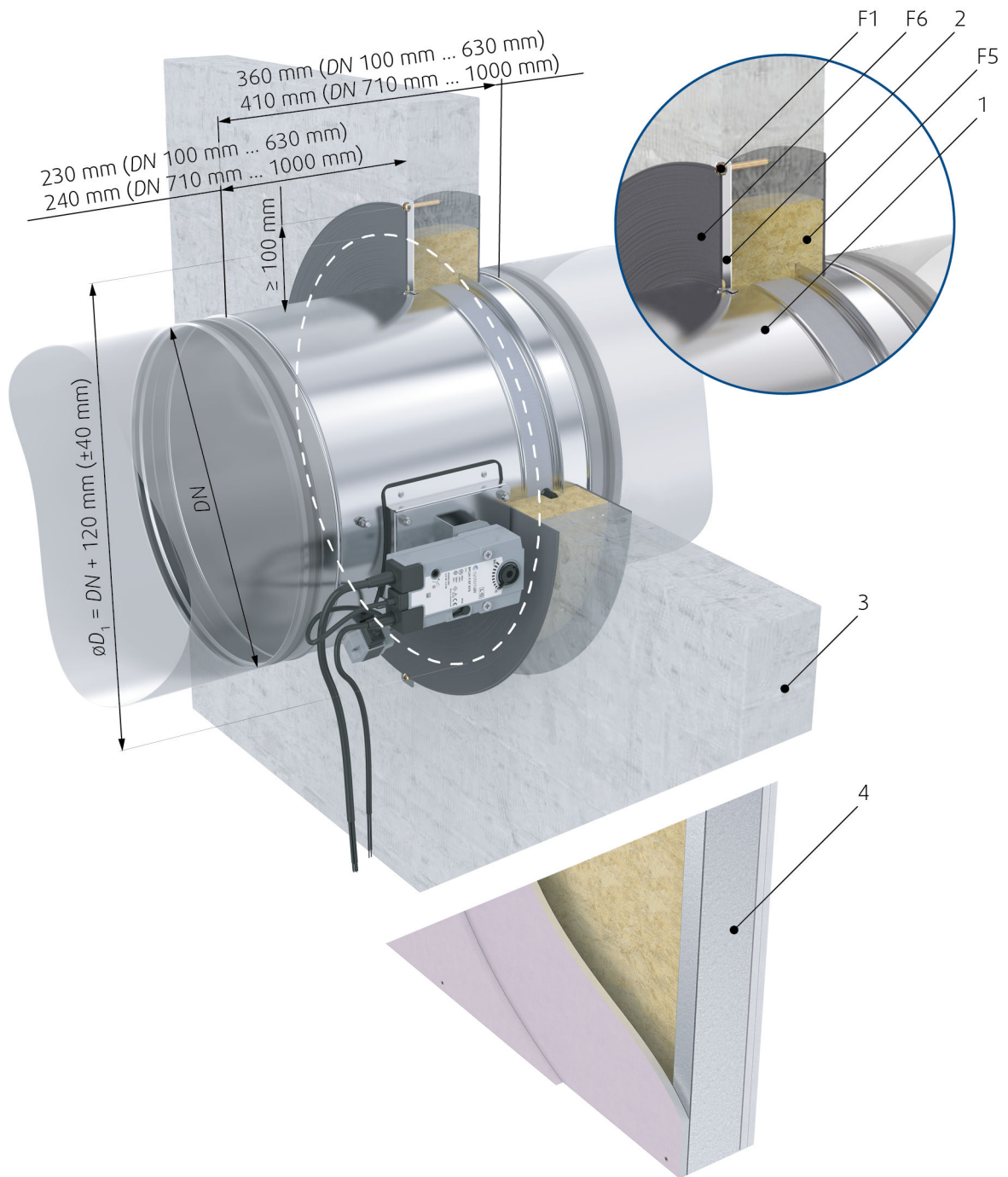

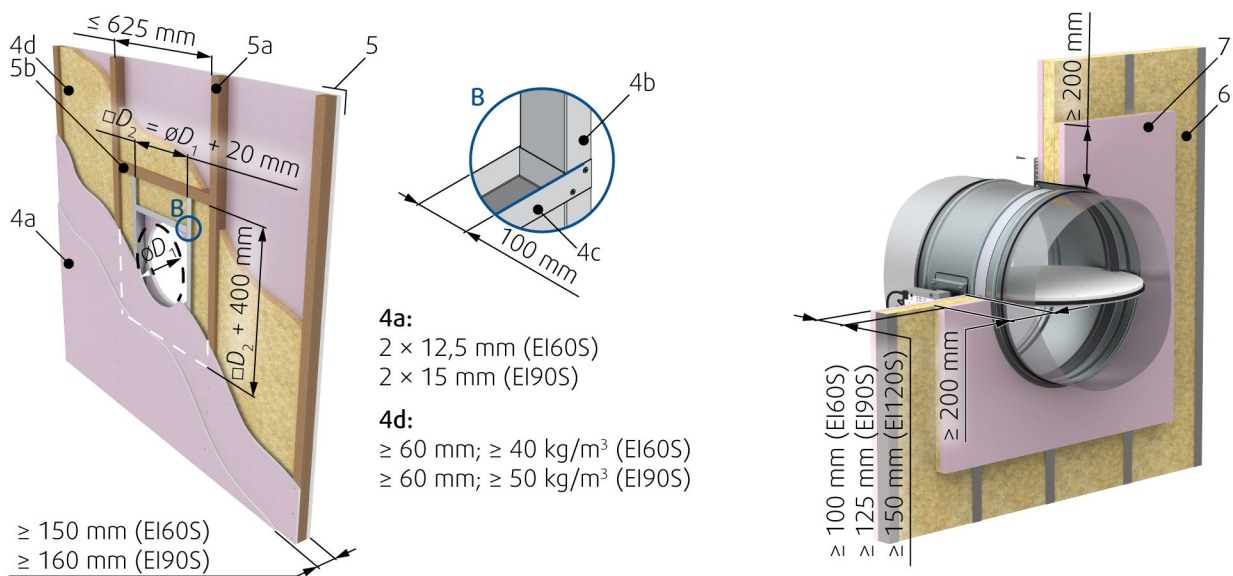
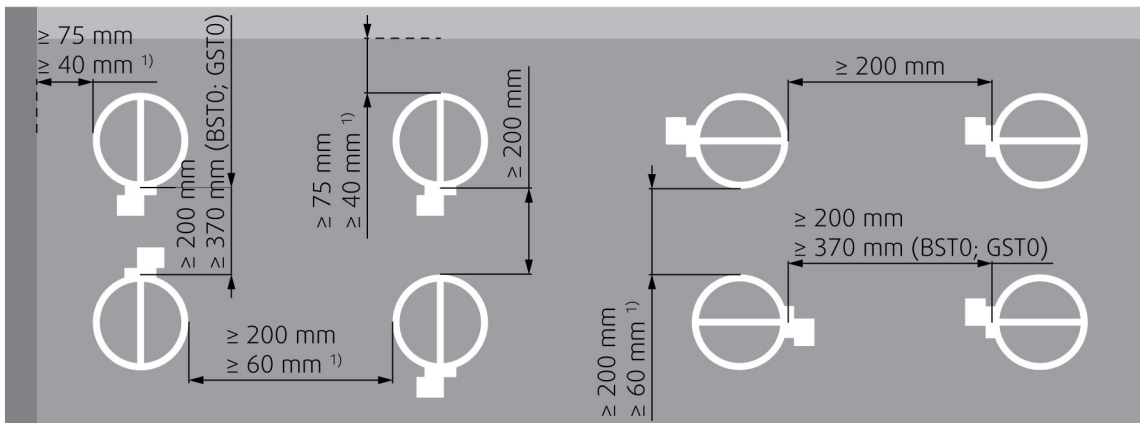
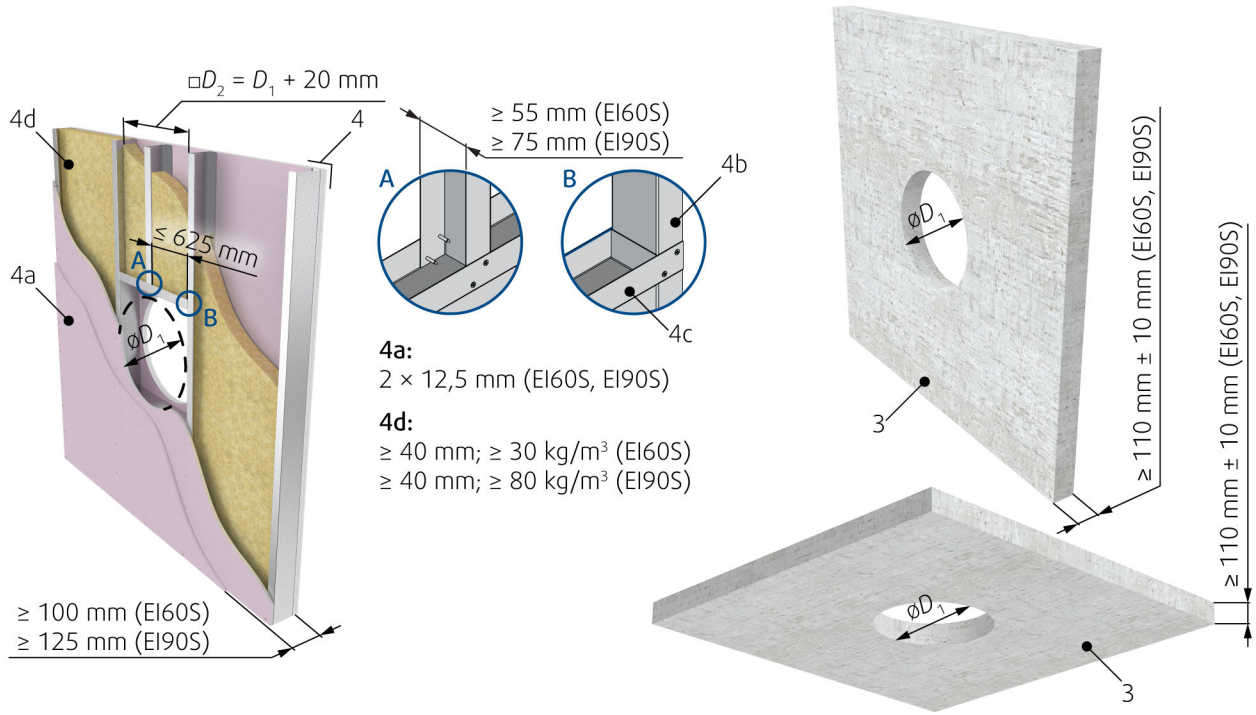

Legend

F1 Screw $\geq 5,5$ DIN7981 or suitable wall plug and screw size 6.

F5 Mineral wool segment (minimum 150 kg/m³).

F6 Layer of fire resistive coating (Promastop-CC/Promat) at least 2 mm thick for exposed surfaces.

1 Fire damper (actuator side)

2 Bendable hanger

3 Concrete/masonry/cellular concrete wall or ceiling

4 Flexible (plasterboard) wall

4a 2 layers of plasterboard fireproof plate type F, EN 520

4b Vertical CW – profiles

4c Horizontal CW – profiles

4d Mineral wool; thickness/cubic density see picture.

5 Flexible (wood beam) wall

5a Vertical spruce wooden beam $\geq 60 \times 100$ mm

5b Horizontal spruce wooden beam $\geq 80 \times 100$ mm

6

Alternative thinner wall (classified in accordance with EN 13501-2:2007 + A1: 2009 for fire resistance required for product application)

7

Area of 200 mm from opening around the damper must have the same composition and be created the same way as Flexible (plasterboard) wall.

Notes:

ve Vertical (wall)

ho Horizontal (floor/ceiling)

Hilti Installation

Filling made only from Hilti foam

With this installation we recommend using flexible connection (see accessory FCR) due thermal expansion of connected ducts during fire. Install the compensator so, that the flexible part has a minimum distance of 50 mm from the edge of a damper's blade in open position.

Tip: Excess material can be reused as the filling for this installation. It can be inserted into the cavity before you add new foam from the gun.

1. The supporting construction opening must be prepared as depicted. Opening surfaces must be even and cleaned off. The flexible wall opening must be reinforced as per the standards for plasterboard walls. The opening dimensions are driven by the nominal dimensions of the damper with added clearance. For circular dampers prepare the opening of diameter D1.
2. Insert the damper into the opening concentric and fixing it with the opening using the bendable hangers and suitable screws (F1).
3. Wear protective gloves when handling foam. Insert the barrel of the foam gun into the middle of the cavity between damper and opening and fill it completely with foam (F17) pushed out foam can be quickly hand pushed back into the cavity.
4. After the filling (F17) is solidified, though it will always remain partly flexible, you can cut the excess foam that stands out from the wall.
5. If needed, uncover and clean the damper after installation.
6. Check the damper's functionality

Installation - Standard Distances





According to the standard EN 1366-2, the minimum distance from the wall or ceiling to the damper body is 75 mm. For multiple crossings through a fire-resistive wall the minimum distance between two damper bodies is 200 mm. This applies to distances between the damper and a nearby foreign object crossing the fire-resistive wall.

Installation - Smaller Distances

The distance between 2 individual fire dampers can be reduced to 60 mm, measured from surface to surface of the housing and the distance between the surface of the damper installed in the duct and the adjacent supporting construction (wall/floor) can be reduced to 40 mm.

Installation in a Wall thinner than tested

Installation in a thinner wall is allowed under the condition that an additional layer/layers of fire protective board are fixed to the surface of the wall in order to achieve the same length of damper penetration seal as was tested. The minimum width of added boards around the damper is 200 mm. In addition, the alternative thinner wall should be classified in accordance with EN 13501-2:2007 + A1: 2009 for fire-resistance required for product application. For a protruding wall, the additional layers must be fixed on the steel supporting construction of the wall.

 3H Hilti	FDR-3G DN100 ... DN630	EI 60 ($v_e - i \leftrightarrow o$) S	 a)	 b)	 360°
		EI 90 ($v_e - i \leftrightarrow o$) S			

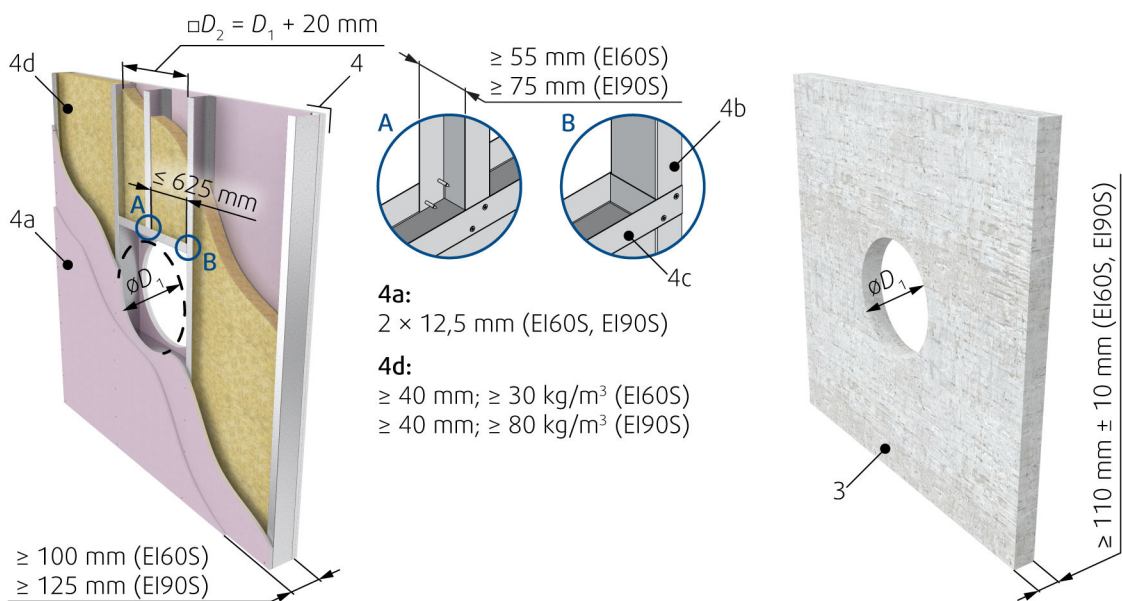
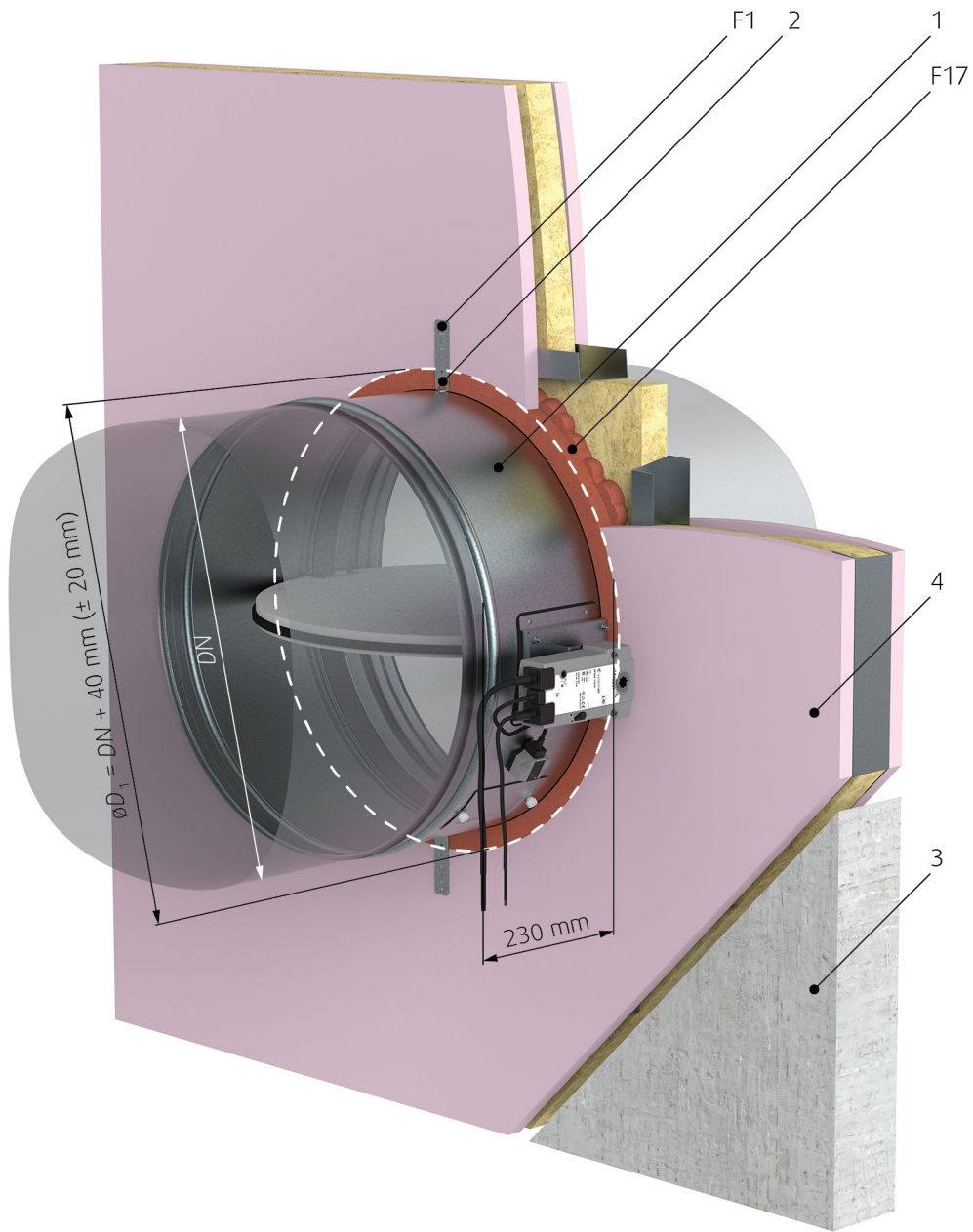

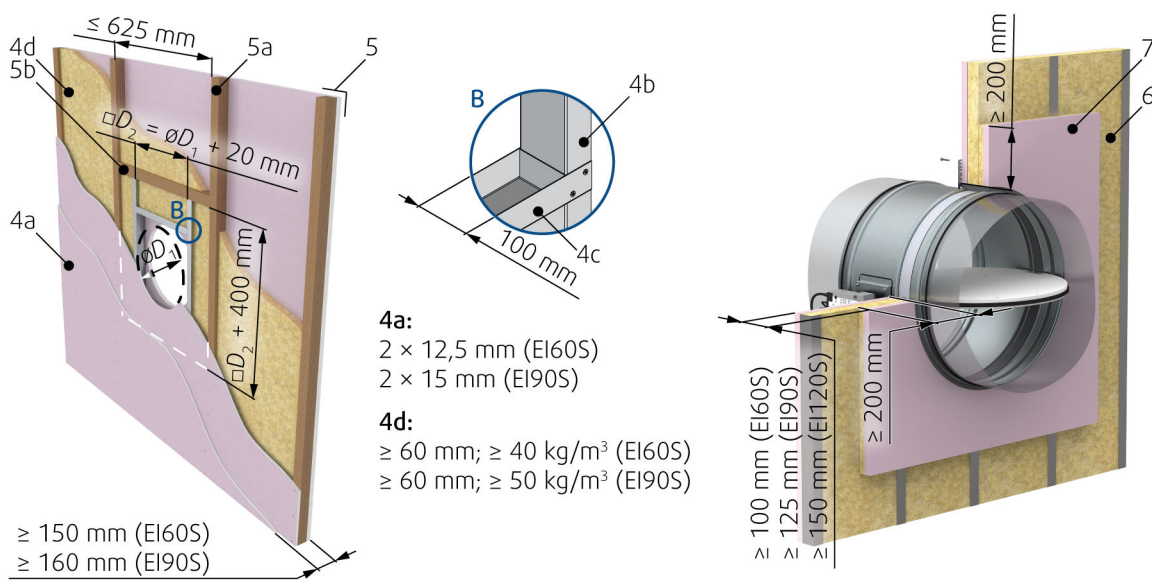
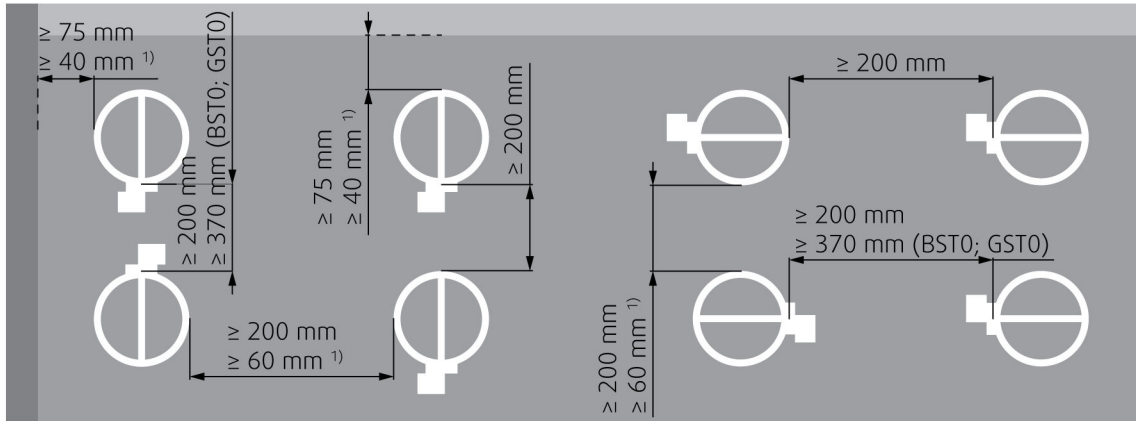

Legend

F1 Screw ≥ 5,5 e.g. DIN7981 or suitable wall plug and screw size 6.

F17 Foam CFS-F FX/HILTI.

1 Fire damper (actuator side)

2 Bendable hanger

3 Concrete/masonry/cellular concrete wall or ceiling

4 Flexible (plasterboard) wall

4a 2 layers of plasterboard fireproof plate type F, EN 520

4b Vertical CW – profiles

4c Horizontal CW – profiles

4d Mineral wool; thickness/cubic density see picture.

5 Flexible (wood beam) wall

5a Vertical spruce wooden beam ≥ 60 × 100 mm

5b Horizontal spruce wooden beam ≥ 80 × 100 mm

6

Alternative thinner wall (classified in accordance with EN 13501-2:2007 + A1: 2009 for fire resistance required for product application)

7

Area of 200 mm from opening around the damper must have the same composition and be created the same way as Flexible (plasterboard) wall.

Notes:

ve Vertical (wall)

1) Smaller distances - maximum resistivity EI90 (ve i<->o) S

ON & OUT of the wall installation, EI90S

Using 2 layers of Mineral Wool

TIP: The duct-wall cavity filling can be also replaced by plaster/mortar/concrete (F2) as a replacement of filling (F9), then the coating (F10) is not needed for the cavity filling.

There are two hanging possibilities, using ringlet MP-MX or using ringlet UVH30 see instructions point 3. Prepare the damper for installation by fastening in the blade and perforation location with ceramic adhesive tape (12) and bind it up using a suitable sheet metal ringlet (13 or 14)





1. The supporting construction opening must be prepared as depicted. Opening surfaces must be even and cleaned off. The flexible wall opening must be reinforced as per the standards for plasterboard walls. The opening dimensions are driven by the nominal dimensions of the damper with added clearance. For circular dampers prepare the opening of diameter D1.
2. Insert the duct into the load-bearing structure along with the damper in such a way that the duct will stick out of the wall to the needed distance. Press the insulation around the duct (F9) and cut its edges to even it with the wall surface. Paint the insulation surface in alignment with the wall with a suitable coat of paint (F10) up to 100 mm from the duct to cover the insulation and part of the wall. Or use as filling
3. Attach the circular damper using L-shaped sheet metal consoles (F11) evenly across the perimeter at 4 points.
4. Depending on the used ringlet embedded in the blade location hang the damper onto:
 - threaded rod M12 (11) when using ringlet MP-MX (13).
 - 2 × threaded rod M10 (15) when using ringlet UVH30 (14).
5. Insulate the damper and duct parts between the damper and the wall. Glue the insulation onto the wall using suitable fire-resistant coating (BSF, ISOVER). Bind the circular damper part and duct insulation with a binding wire (9) for both layers of insulation in the usual way that is applied when insulating circular ducts.
6. Cover the insulation face and perimeter up to 150 mm from the insulation edge using galvanized sheet metal (accessory A2), secure the sheet against the damper housing through accessories holes (10). Any protruding screws which could stand in the way of the blade during its opening need to be shortened so that they don't prevent blade movement.
7. If needed, uncover and clean the damper after installation.
8. Make sure the fixing screws are not interfering with the blade movement and check the damper's functionality.

Installation Distances

For installation 5.1 ON & OUT, the minimum distance from the wall or ceiling to the damper body is 200 mm. For multiple crossings through a fire-resistant wall the minimum distance between two damper bodies is 400 mm. A distance of 200 mm applies for distances between the damper and a nearby foreign object crossing the fire-resistant wall.

Installation in a Wall thinner than tested

Installation in a thinner wall is allowed under the condition that an additional layer/layers of fire protective board are fixed to the surface of the wall in order to achieve the same length of damper penetration seal as was tested. The minimum width of added boards around the damper is 200 mm. In addition, the alternative thinner wall should be classified in accordance with EN 13501-2:2007 + A1: 2009 for fire-resistance required for product application. For a protruding wall, the additional layers must be fixed on the steel supporting construction of the wall.

 5.1 On, Out	FDR-3G DN100 ... DN400	EI 60 ($v_e - i \leftrightarrow o$) S	a)  b) 	
		EI 90 ($v_e - i \leftrightarrow o$) S		

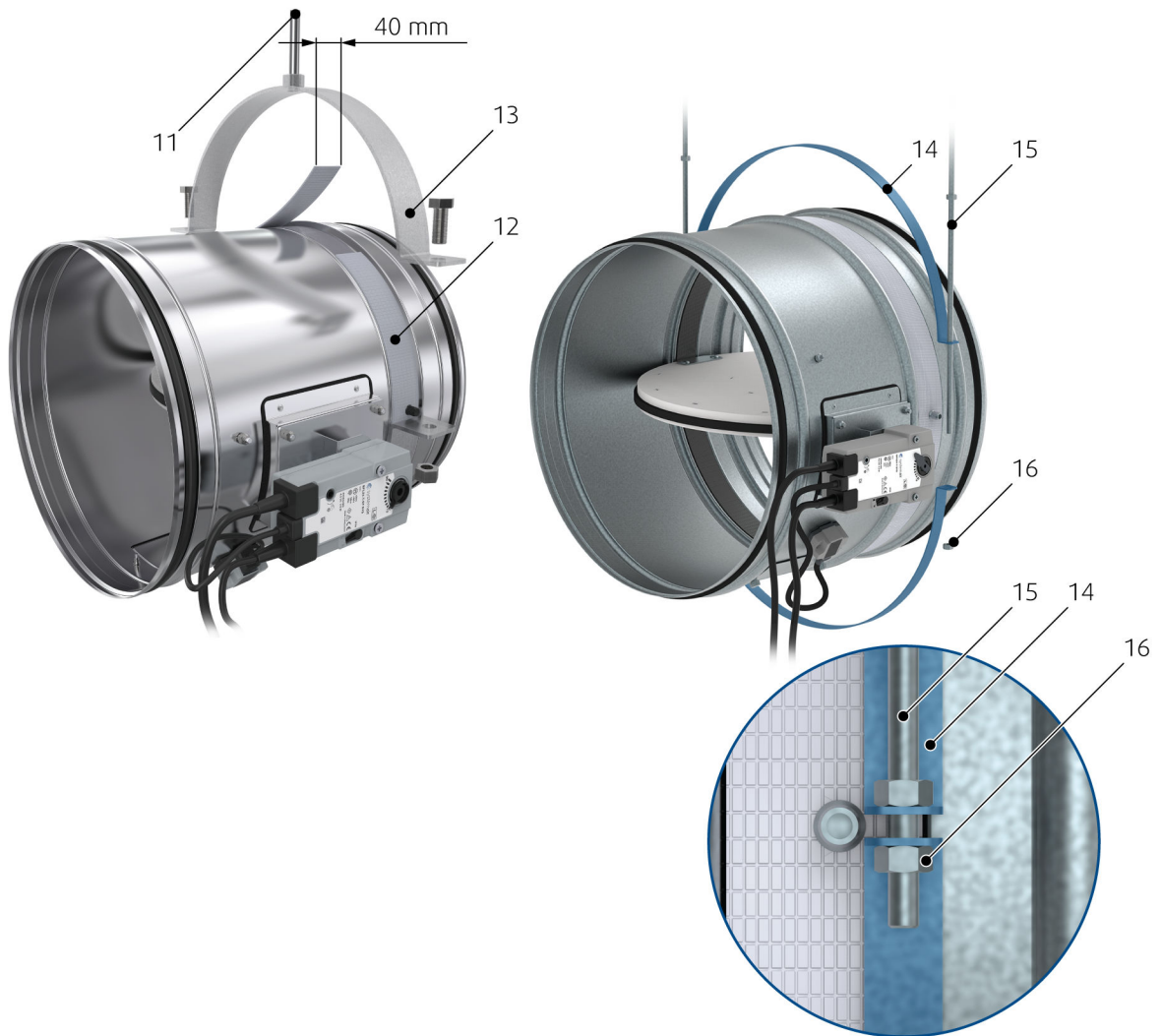
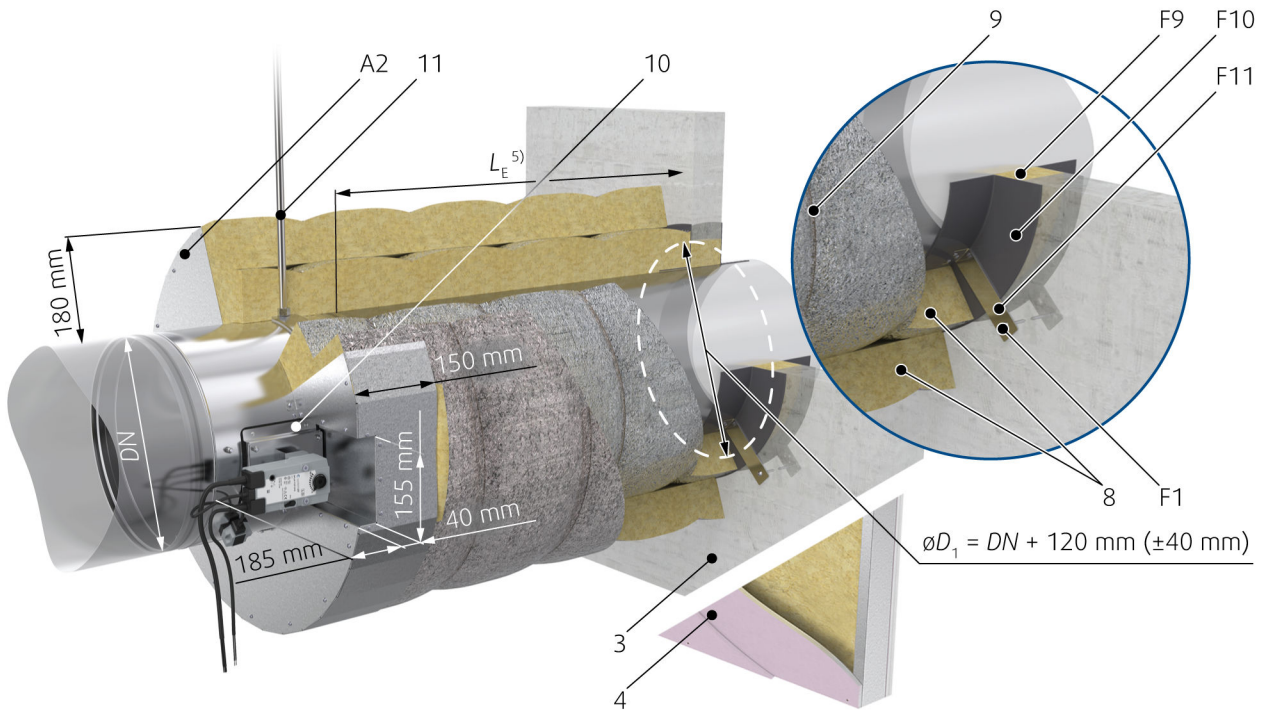

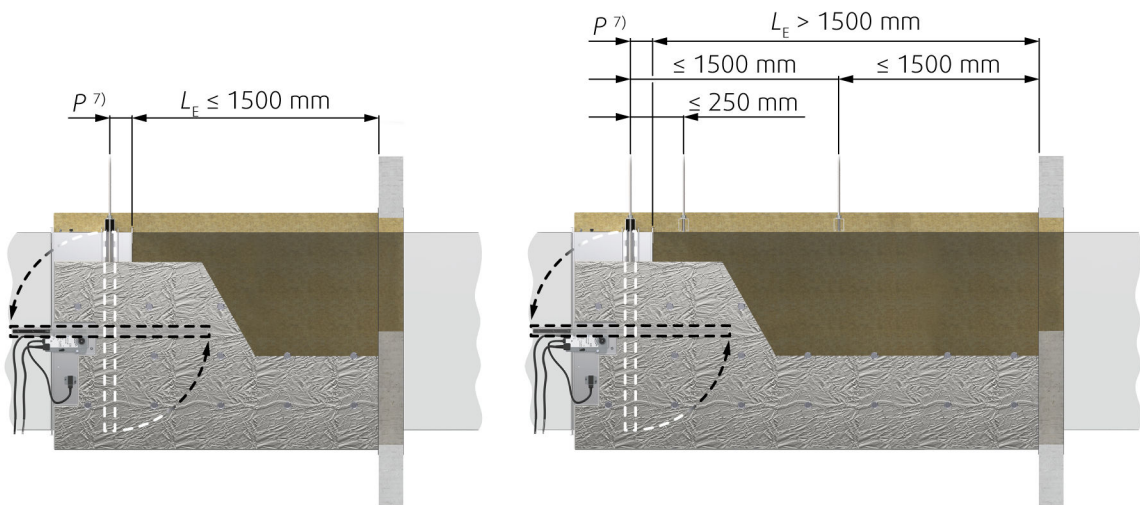
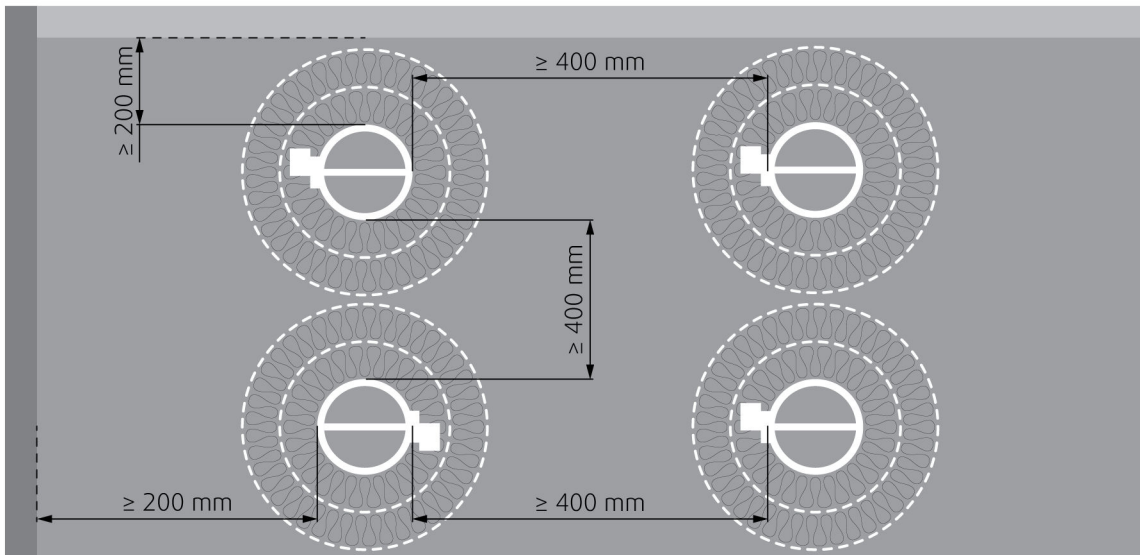
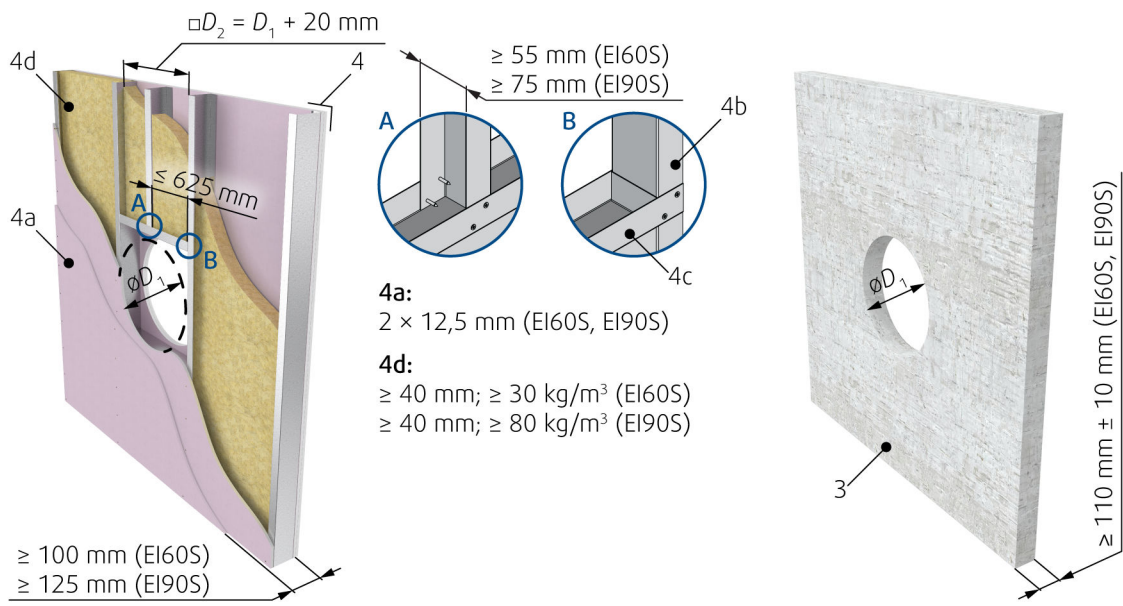

Legend

- F9** Mineral wool segment (min. 66 kg/m³) - in a wall
- F10** Layer of fire resistive coating (BSF/ISOVER) at least 2 mm thick for exposed surfaces
- F11** Sheet metal belt 40 × 2 mm bent into an L shape of 35 and 160 mm
- A2** Insulation front cover IPOR-FD-DN (accessory)
- 1** Fire damper (actuator side)
- 3** Concrete/masonry/brick/cellular concrete wall or ceiling
- 4** Flexible (plasterboard) wall
 - 4a** 2 layers of plasterboard fireproof plate type F, EN 520
 - 4b** Vertical CW – profiles
 - 4c** Horizontal CW – profiles
 - 4d** Mineral wool; thickness/cubic density see picture.
- 8** Mineral wool segment ULTIMATE Protect Wired Mat 4.0 Alu1/ISOVER (min. 66 kg/m³) - inner layer & outer layer
- 9** Steel binding wire thickness 1,6 mm
- 10** Screw 3,9 × max. 13; e.g. DIN7504
- 11** Steel threaded rod M12 (1 ×)
- 12** Ceramic tape (A-KERA) width 40 mm, thickness 2 mm
- 13** Sheet metal ringlet for damper suspension (MP-MX/HILTI), when using 1 × M12 rod
- 14** Sheet metal ringlet for damper suspension (UVH30, Lindab), when using 2 × M10 rod
- 15** Steel threaded rod M10 (2 ×)
- 16** Nut M10 (4 ×)

Notes:

ve Vertical (wall)

(5)

Rules for hanger placements and duct suspensions depend on the dampers distance from the supporting construction
LE

(7)

The distance P is the distance from the blade axis to the damper flange. The distance depends on the type of damper used.

F2

Plaster/mortar/concrete filling - can serve as replacement of filling F9. Using Plaster/mortar/concrete filling the coating F10 is not needed.

ON & OUT of the wall installation, EI60S

Using 1 layer of Mineral Wool

TIP: The duct-wall cavity filling can be also replaced by plaster/mortar/concrete (F2) as a replacement of filling (F9), then the coating (F10) is not needed for the cavity filling.

There are two hanging possibilities, using ringlet MP-MX or using ringlet UVH30 see instructions point 3. Prepare the damper for installation by fastening in the blade and perforation location with ceramic adhesive tape (12) and bind it up using a suitable sheet metal ringlet (13 or 14)





1. The supporting construction opening must be prepared as depicted. Opening surfaces must be even and cleaned off. The flexible wall opening must be reinforced as per the standards for plasterboard walls. The opening dimensions are driven by the nominal dimensions of the damper with added clearance. For circular dampers prepare the opening of diameter D1.
2. Insert the duct into the load-bearing structure along with the damper in such a way that the duct will stick out of the wall to the needed distance. Press the insulation around the duct (F9) and cut its edges to even it with the wall surface. Paint the insulation surface in alignment with the wall with a suitable coat of paint (F10) up to 100 mm from the duct to cover the insulation and part of the wall. Or use as filling.
3. Reinforce the circular duct from both sides of the wall crossing with ringlets MP-MX (13) or ringlets UVH30 (14).
4. Depending on the used ringlet embedded in the blade location hang the damper onto:
 - threaded rod M12 (11) when using ringlet MP-MX, Hilti (13).
 - 2 × threaded rod M10 (15) when using ringlet UVH30, Lindab (14) with nuts (16).
5. Insulate the damper and duct parts between the damper and the wall. Entwine the circular damper and duct with one layer of insulation (17). Glue the insulation onto the wall using a suitable fire-resistive coating (F10). Secure the insulation (17) with a binding wire (ϕ 1,6 mm) in the standard way that is applied when insulating circular ducts or by using wire clamps (26) to sew together the meshes on the top of the insulation (17). The actuator, thermosensor, and inspection lid must remain uninsulated with a gap of a max. of 15 mm.
6. Around the front side and on all surfaces that are not covered with aluminum foil, apply aluminum tape (25).
7. If needed, uncover and clean the damper after installation.
8. Make sure the fixing screws are not interfering with the blade movement and check the damper's functionality.

Installation Distances

For installation 5.2 ON & OUT, the minimum distance from the wall or ceiling to the damper body is 100 mm. For multiple crossings through a fire-resistive wall the minimum distance between two damper bodies is 200 mm. A distance 200 mm also applies for distances between the damper and a nearby foreign object crossing the fire-resistive wall.

Installation in a Wall thinner than tested

Installation in a thinner wall is allowed under the condition that an additional layer/layers of fire protective board are fixed to the surface of the wall in order to achieve the same length of damper penetration seal as was tested. The minimum width of added boards around the damper is 200 mm. In addition, the alternative thinner wall should be classified in accordance with EN 13501-2:2007 + A1: 2009 for fire-resistance required for product application. For a protruding wall, the additional layers must be fixed on the steel supporting construction of the wall.

 <p>FDR-3G DN100 ... DN500 5.2 On, Out</p>	<p>FDR-3G DN100 ... DN500</p>	<p>EI 60 (v_e - i ↔ o) S</p>	<p>a) </p>	<p>b) </p>	
---	-----------------------------------	--	---	--	---

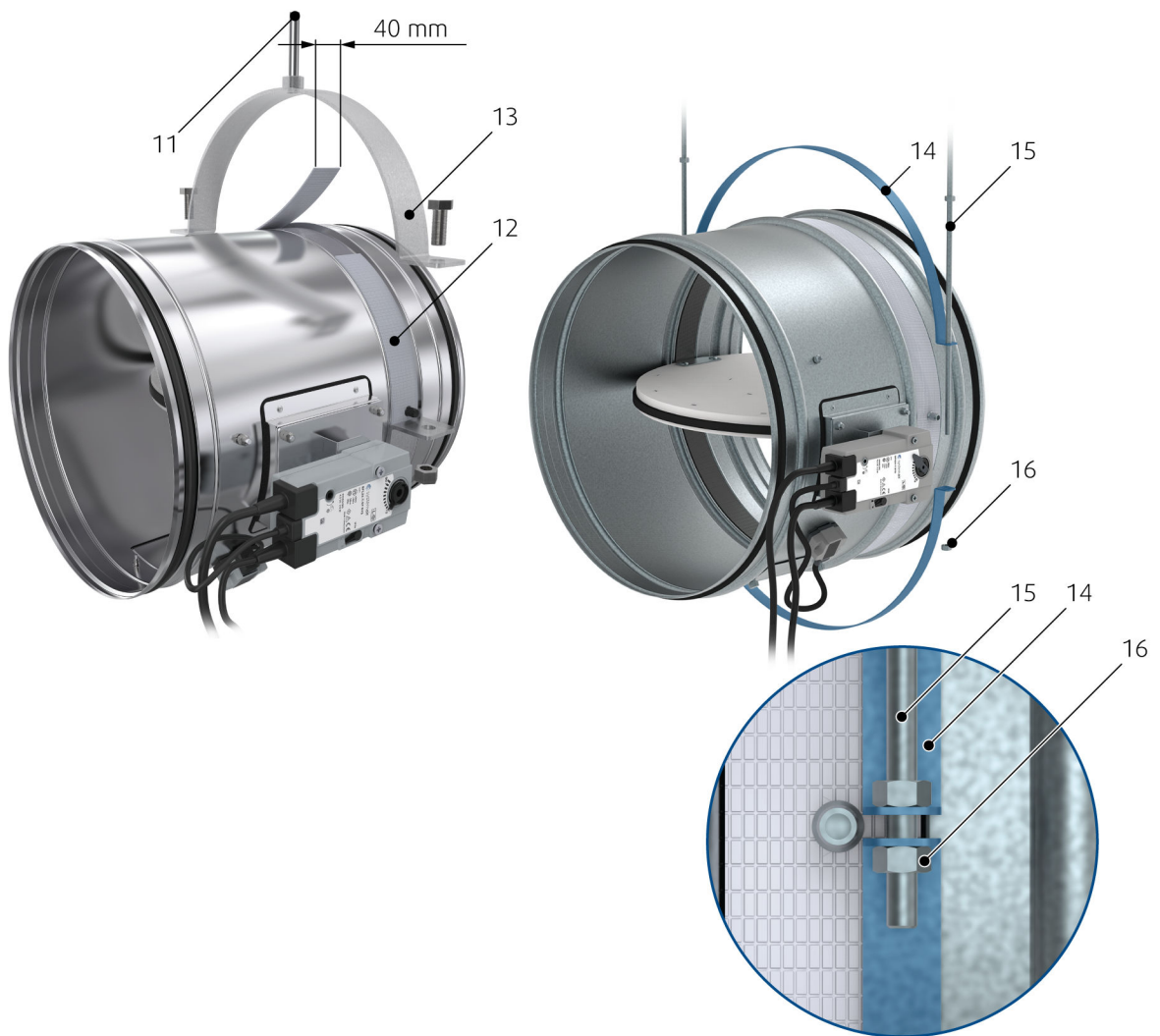
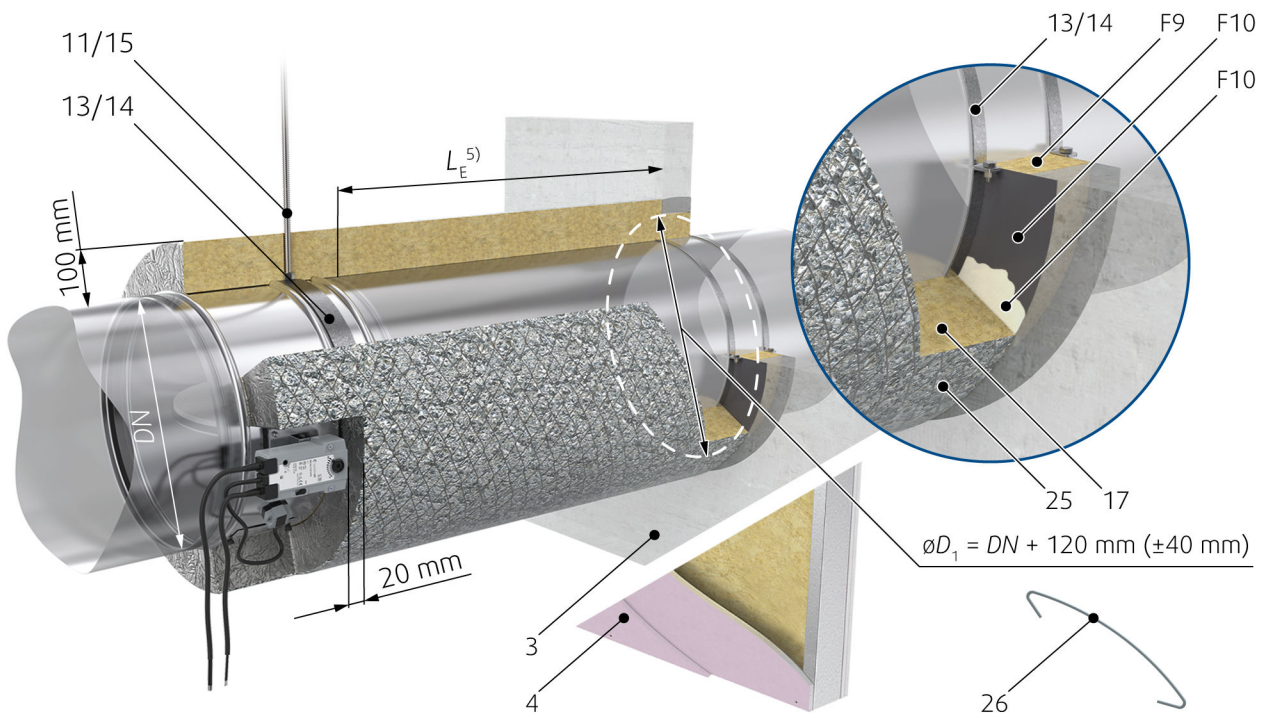

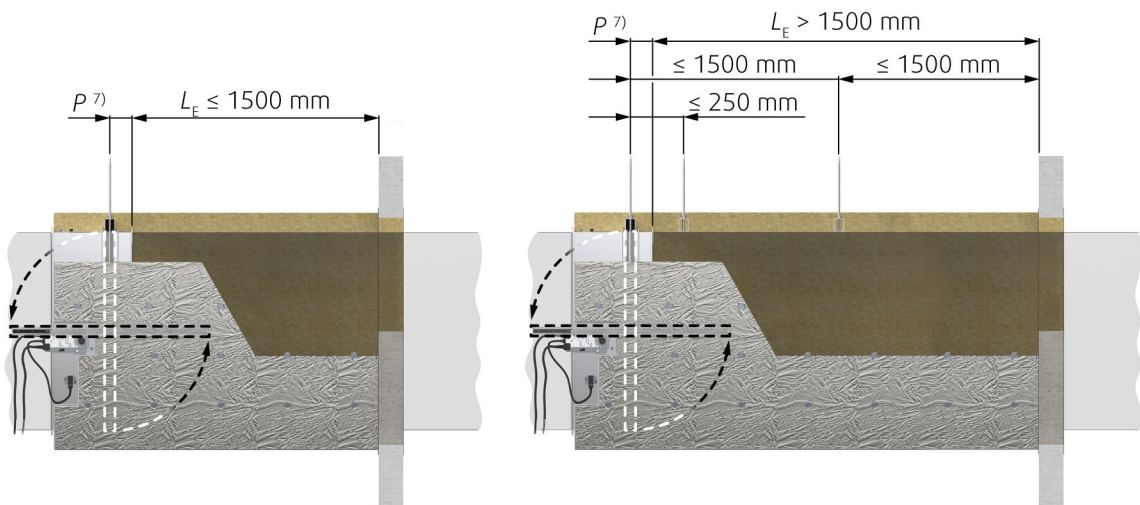
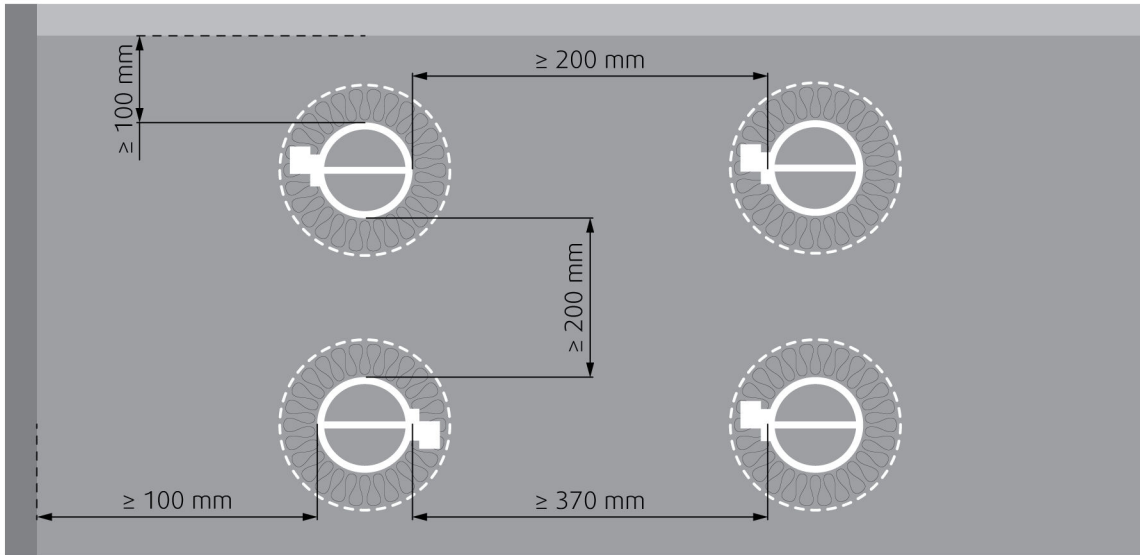
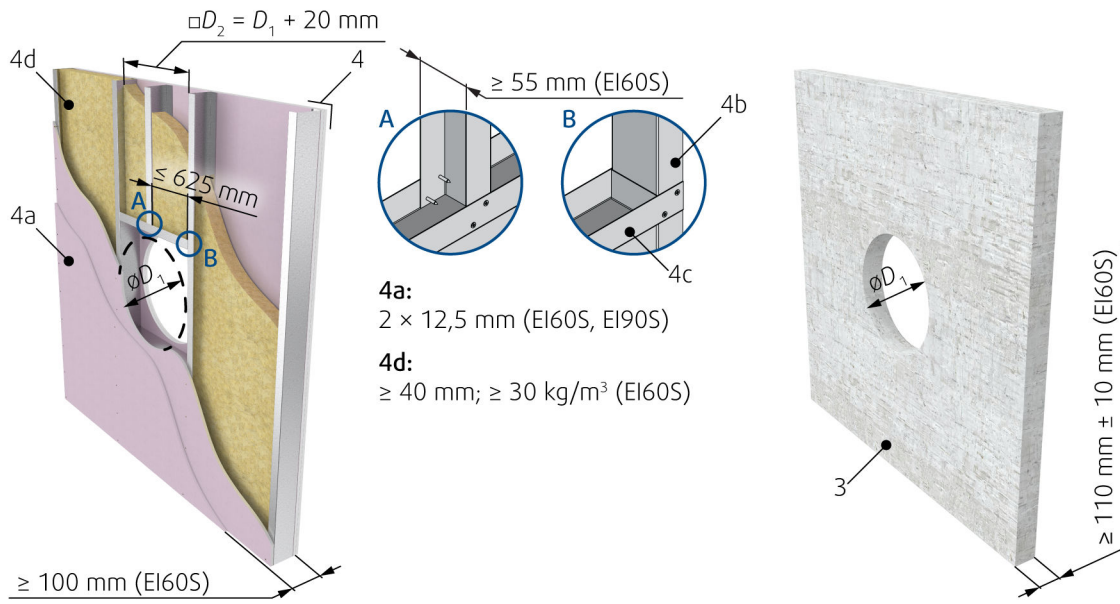

Legend

- F9** Mineral wool segment (min. 66 kg/m³) - in a wall
- F10** Layer of fire resistive coating (BSF/ISOVER) at least 2 mm thick for exposed surfaces
- 1** Fire damper (actuator side)
- 3** Concrete/masonry/brick/cellular concrete wall or ceiling
- 4** Flexible (plasterboard) wall
- 4a** 2 layers of plasterboard fireproof plate type F, EN 520
- 4b** Vertical CW – profiles
- 4c** Horizontal CW – profiles
- 4d** Mineral wool; thickness/cubic density see picture.
- 11** Steel threaded rod M12 (1 ×)
- 12** Ceramic tape (A-KERA) width 40 mm, thickness 2 mm
- 13** Sheet metal ringlet for damper suspension (MP-MX, HILTI), when using 1 × M12 rod
- 14** Sheet metal ringlet for damper suspension (UVH30, Lindab), when using 2 × M10 rod
- 15** Steel threaded rod M10 (2 ×)
- 16** Nut M10 (4 ×)
- 17** Mineral wool ULTIMATE Protect Slab 4.0 Alu1/ISOVER (min. 66 kg/m³)
- 25** Aluminium tape around the front side and on places uncovered with alufoil
- 26** Wire clamp for U-ProtectWiredMat fixation

Notes:

ve Vertical (wall)

(5)

Rules for hanger placements and duct suspensions depend on the dampers distance from the supporting construction
LE

(7)

The distance P is the distance from the blade axis to the damper flange. The distance depends on the type of damper used.

F2

Plaster/mortar/concrete filling - can serve as replacement of filling F9. Using Plaster/mortar/concrete filling the coating F10 is not needed.

Electrical connections

T/PC/A	DN (mm)																				
	100	125	140	150	160	180	200	225	250	280	315	355	400	450	500	560	630	710	800	900	1000
	B230T/6,5 VA/BFL230-T B24T/4 VA/BFL24-T B24T-W/4 VA/BFL24-T-ST BST0/11 VA/BFL24-T-ST + BKN230-24 B24T-SR / 6,5 VA / BFL24-T-SR										B230T/10 VA/ BFN230-T B24T/6 VA/BFN24-T B24T-W/6 VA/BFN24-T-ST BST0/11 VA/BFN24-T-ST + BKN230-24 B24T-SR / 8,5 VA / BFN24-T-SR					B230T/11 VA/BF230-T B24T/10 VA/BF24-T B24T-W/10 VA/BF24-T-ST BST0/11 VA/BF24-T-ST + BKN230-24 B24T-SR-KR / 9,5 VA / BF24-T-SR					

T/PC/A	DN (mm)																			
	100	125	140	150	160	180	200	225	250	280	315	355	400	450	500	560	630	710	800	900
	G230T-KR/9,5 VA/340TA-230-05... G24T-KR/9 VA/340TA-024-05... G24T-W-KR/9 VA/340TA-024-05...ST01 GST0-KR/11 VA/340TA-024-05...ST01 + fs-UFC24-2 G24T-SR-KR/7,5 VA/340CTA-024-05...										G230T-KR/11,5 VA/360TA-230-12... G24T-KR/7 VA/360TA-024-12... G24T-W-KR/7 VA/360TA-024-12...ST01 GST0-KR/9 VA/360TA-024-12...ST01 + fs-UFC24-2 G24T-SR-KR/8 VA/360CTA-024-12...									

T/PC/A - Activation Type / Power Consumption / Actuator

Type of activation H0

This type of activation mechanism does not have any electrical equipment.

Type of activation H2

IMPORTANT: Risk of electric shock! Switch off the power supply before working on any electrical equipment.

Only qualified electricians are allowed to work on the electrical system.

Microswitch: Power Supply: 125/250V AC or 12/24V DC Electric Parameters: 3A

NOTES:

- Supply via safety isolation transformer.
- Power consumption must be observed!

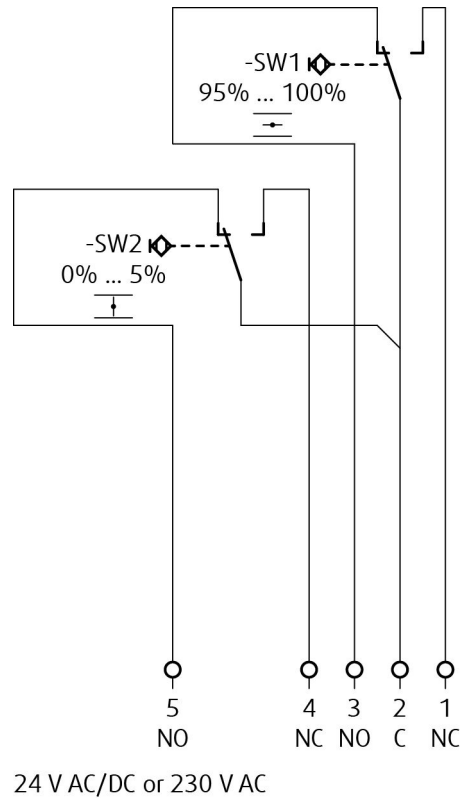

Legend

- 1 Grey cable colour
- 2 Orange cable colour
- 3 Pink cable colour
- 4 White cable colour
- 5 Red cable colour
- 6 Brown cable colour (Do not use for type of activation H2)
- X:7 Blue cable colour (Do not use for type of activation H2)

Type of activation H5-2

IMPORTANT: Risk of electric shock!

Switch off the power supply before working on any electrical equipment.

Only qualified electricians are allowed to work on the electrical system.

Microswitch:

Power Supply: 125/250V AC or 12/24V DC

Electric Parameters: 3A

Impulse Electromagnet:

Power Supply: AC (50/60 Hz)/DC 24 V

Electric Parameters: 50 VA, load factor 10% (maximum 30 seconds in operation)

NOTES:

- 50 VA = Nominal activation power, maximum permissible magnet load = 300 VA
- Supply via safety isolation transformer.
- Power consumption must be observed!

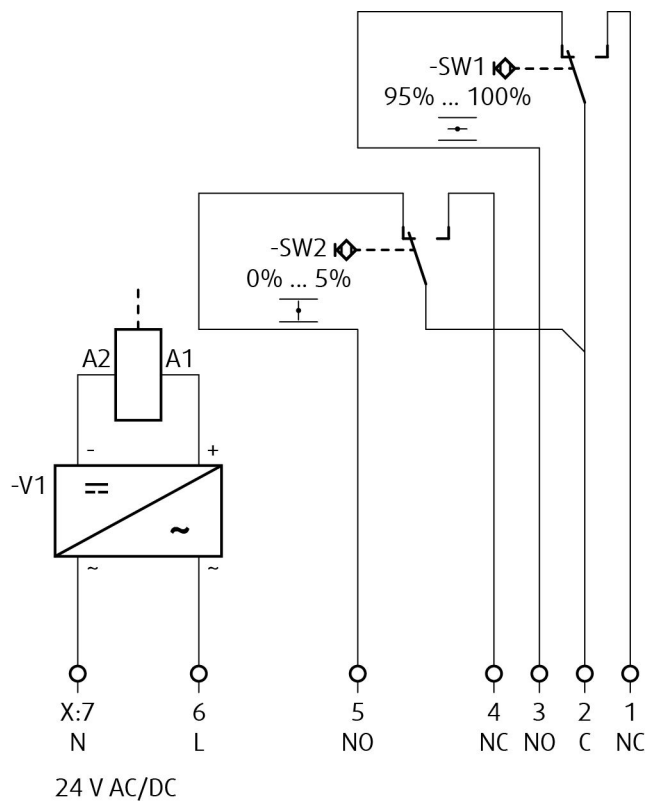

Legend

- 1 Grey cable colour
- 2 Orange cable colour
- 3 Pink cable colour
- 4 White cable colour
- 5 Red cable colour
- 6 Brown cable colour
- X:7 Blue cable colour

Type of activation H6-2

IMPORTANT: Risk of electric shock!

Switch off the power supply before working on any electrical equipment.

Only qualified electricians are allowed to work on the electrical system.

Microswitch:

Power Supply: 125/250V AC or 12/24V DC

Electric Parameters: 3A

Impulse Electromagnet:

Power Supply: 230V AC, 50/60 Hz

Electric Parameters: 50 VA, load factor 10% (maximum 30 seconds in operation)

NOTES:

- 50 VA = Nominal activation power, maximum permissible magnet load = 300 VA
- Caution! Main power supply voltage!
- A device that disconnects the pole conductors (minimum contact gap 3 mm) is required for isolation from the power supply.
- Power consumption must be observed!

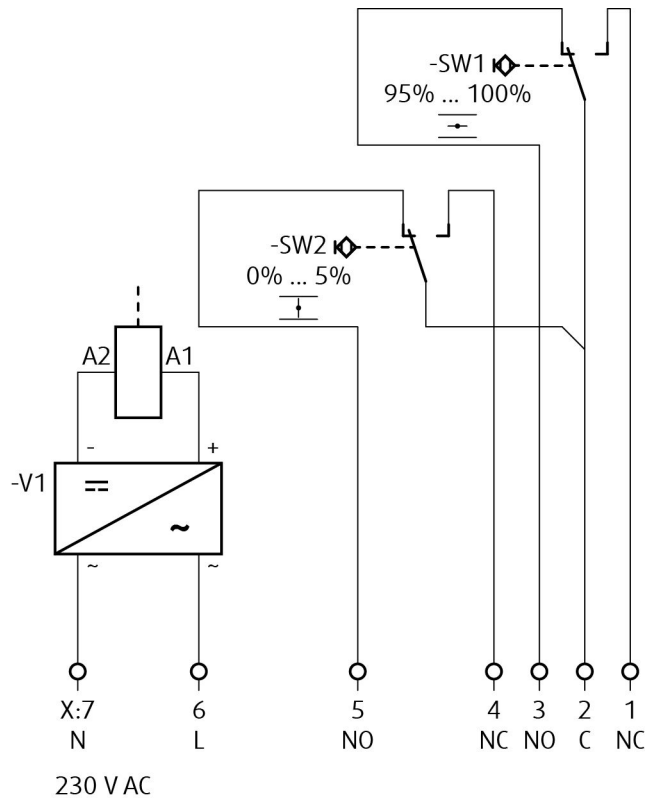

Legend

- 1 Grey cable colour
- 2 Orange cable colour
- 3 Pink cable colour
- 4 White cable colour
- 5 Red cable colour
- 6 Brown cable colour
- X:7 Blue cable colour

Type of activation B230T

IMPORTANT: Risk of electric shock!

Switch off the power supply before working on any electrical equipment.

Only qualified electricians are allowed to work on the electrical system.

Actuator power supply: 230V AC, 50/60 Hz

NOTES:

- Caution! Main power supply voltage!
- A device that disconnects the pole conductors (minimum contact gap 3 mm) is required for isolation from the power supply.
- Parallel connection of several actuators possible.
- Power consumption must be observed!

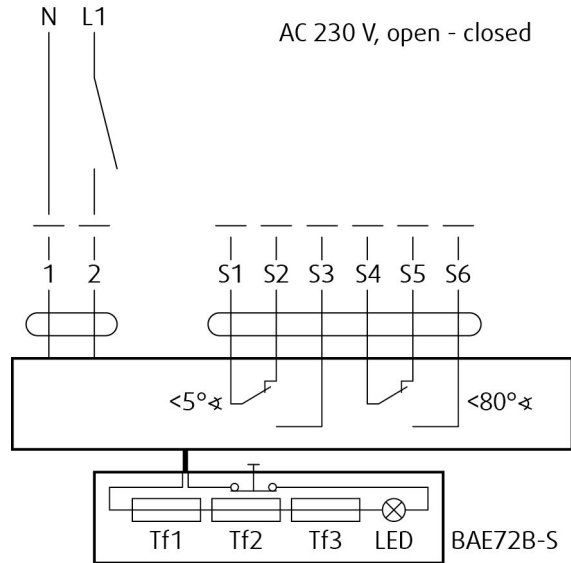

Legend

- 1** Blue cable colour
- 2** Brown cable colour
- S1** Violet cable colour
- S2** Red cable colour
- S3** White cable colour
- S4** Orange cable colour
- S5** Pink cable colour
- S6** Grey cable colour
- Tf** Thermal fuse

Type of activation G230T

IMPORTANT: Risk of electric shock!

Switch off the power supply before working on any electrical equipment.

Only qualified electricians are allowed to work on the electrical system.

Actuator power supply: 230V AC, 50/60 Hz

NOTES:

- Caution! Main power supply voltage!
- A device that disconnects the pole conductors (minimum contact gap 3 mm) is required for isolation from the power supply.
- Parallel connection of several actuators possible.
- Power consumption must be observed!

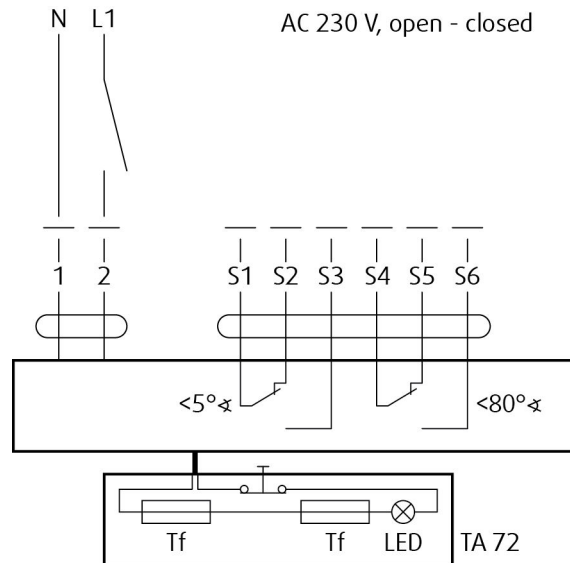

Type of activation B24T

IMPORTANT: Risk of electric shock!

Switch off the power supply before working on any electrical equipment.

Only qualified electricians are allowed to work on the electrical system.

Actuator power supply: AC (50/60 Hz)/DC 24 V

NOTES:

- Supply via safety isolation transformer.
- Parallel connection of several actuators possible.
- Power consumption must be observed!

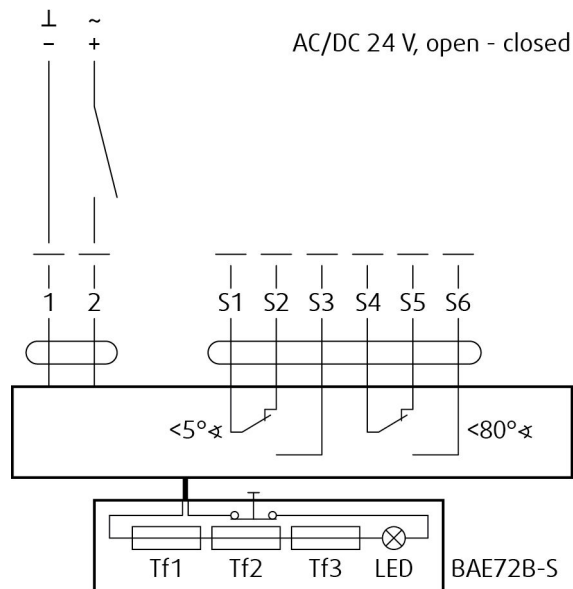

Legend

- 1** Blue cable colour (black for BF24-T)
- 2** Red cable colour (white for BF24-T)
- S1** Violet cable colour (white for BF24-T)
- S2** Red cable colour (white for BF24-T)
- S3** White cable colour (white for BF24-T)
- S4** Orange cable colour (white for BF24-T)
- S5** Pink cable colour (white for BF24-T)
- S6** Grey cable colour (white for BF24-T)
- Tf** Thermal fuse

Type of activation G24T

IMPORTANT: Risk of electric shock!

Switch off the power supply before working on any electrical equipment.

Only qualified electricians are allowed to work on the electrical system.

Actuator power supply: AC (50/60 Hz)/DC 24 V

NOTES:

- Supply via safety isolation transformer.
- Parallel connection of several actuators possible.
- Power consumption must be observed!

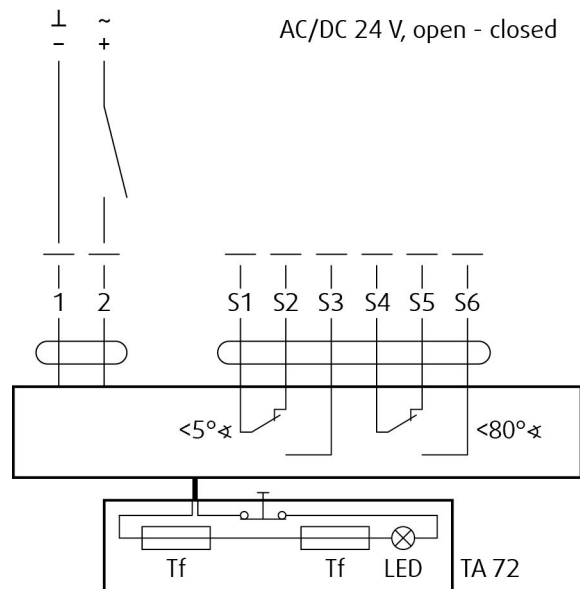

Legend

- 1** Black cable colour
- 2** Red cable colour
- S1** Violet cable colour
- S2** Red cable colour
- S3** White cable colour
- S4** Orange cable colour
- S5** Pink cable colour
- S6** Grey cable colour
- Tf** Thermal fuse

Type of activation BST0

IMPORTANT: Risk of electric shock!

Switch off the power supply before working on any electrical equipment.

Only qualified electricians are allowed to work on the electrical system.

This type of activation is with a Belimo supply and communication unit BKN230-24 (other communication units on demand).

Actuator power supply: AC (50/60 Hz)/DC 24 V

NOTES:

- Connection scheme for standardly fitted BKN230-24.
- Power consumption must be observed.

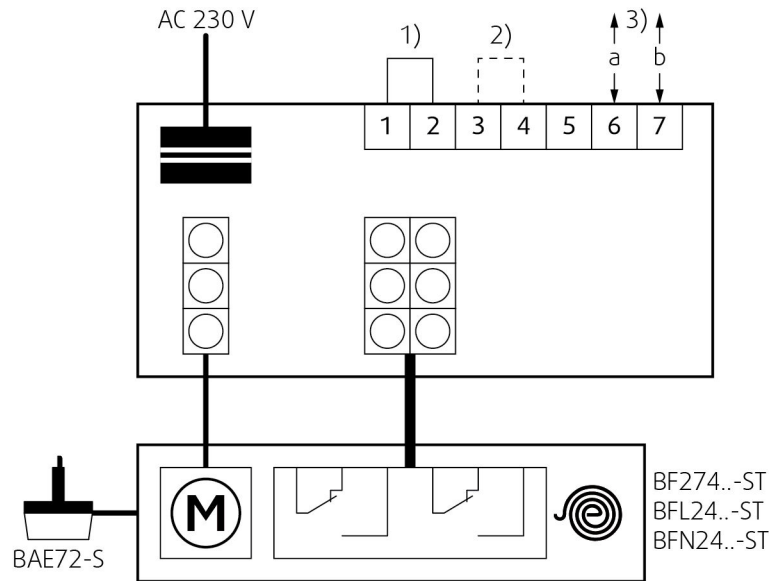

Legend

1)

Jumper factory-fitted. Can be removed if necessary to be replaced by a thermoelectric trip (the safety function will be triggered if terminals 1 and 2 are not linked).

2) Jumper only used for commissioning purposes and without BKS24-.. !

3) 2-wire conductor to BKS24-..

Type of activation GSTO

IMPORTANT: Risk of electric shock!

Switch off the power supply before working on any electrical equipment.

Only qualified electricians are allowed to work on the electrical system.

This type of activation is with a Gruner supply and communication unit fs-UFC24-2 (other communication units on demand).

Actuator power supply: AC (50/60 Hz)/DC 24 V

NOTES:

- Supply via safety isolation transformer.
- Power consumption must be observed!

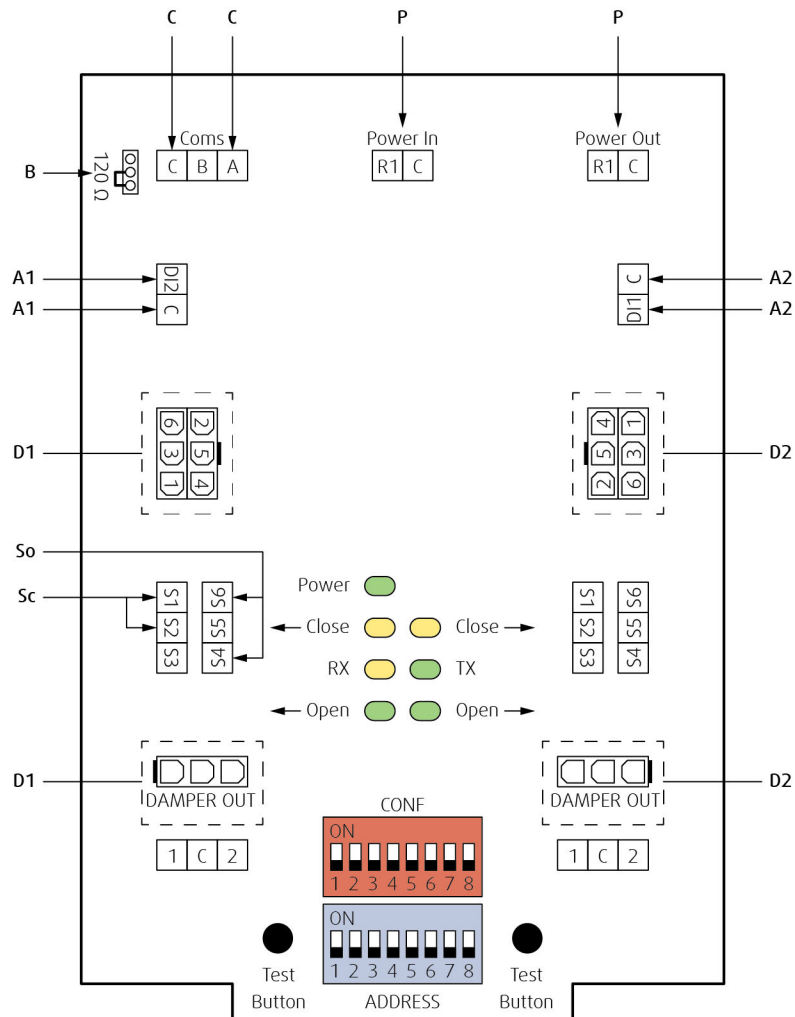

Legend

A1, A2

Analogue Application; Digital input for manual override can be selected via bus as „Normally Open“ (= standard open) or „Normally Closed“ (= standard closed) Default: „Normally Open“

B Position of line termination 120 ohm if FS-UFC24-2 is last Modbus or BACnet device in line

C RS-485 Coms; Modbus RTU or BACnet MS/TP dip switch selectable

D1, D2 Damper 1, Damper 2; Fire or smoke extraction application

P Main power 24 V AC/DC; Daisy chain from and to other FS-UFC24-2

So Contact open

Sc Contact closed

Type of activation B24T-W

IMPORTANT: Risk of electric shock!

Switch off the power supply before working on any electrical equipment.

Only qualified electricians are allowed to work on the electrical system.

This type of activation is with provided cable connectors for the supply and communication unit (communication unit not part of the mechanism).

Actuator power supply: AC (50/60 Hz)/DC 24 V

NOTES:

- Supply via safety isolation transformer.
- Parallel connection of several actuators possible.
- Power consumption must be observed!

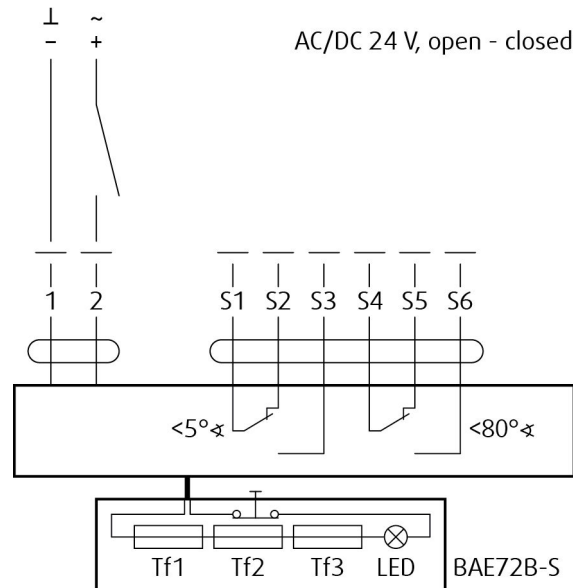

Legend

- 1** Blue cable colour (black for BF24-T) in connector 1
- 2** Brown cable colour (white for BF24-T) in connector 1
- S1** Violet cable colour (white for BF24-T) in connector 2
- S2** Red cable colour (white for BF24-T) in connector 2
- S3** White cable colour (white for BF24-T) in connector 2
- S4** Orange cable colour (white for BF24-T) in connector 2
- S5** Pink cable colour (white for BF24-T) in connector 2
- S6** Grey cable colour (white for BF24-T) in connector 2
- Tf** Thermal fuse

Type of activation G24T-W

IMPORTANT: Risk of electric shock!

Switch off the power supply before working on any electrical equipment.

Only qualified electricians are allowed to work on the electrical system.

This type of activation is with provided cable connectors for the supply and communication unit (communication unit not part of the mechanism).

NOTES:

- Supply via safety isolation transformer.
- Parallel connection of several actuators possible.
- Power consumption must be observed!

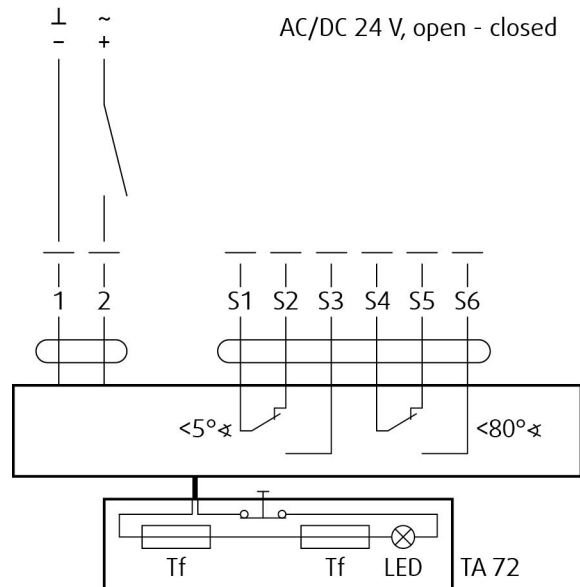

Legend

- 1** Black cable colour (black for BF24-T) in connector 1
- 2** Red cable colour (white for BF24-T) in connector 1
- S1** Violet cable colour (white for BF24-T) in connector 2
- S2** Red cable colour (white for BF24-T) in connector 2
- S3** White cable colour (white for BF24-T) in connector 2
- S4** Orange cable colour (white for BF24-T) in connector 2
- S5** Pink cable colour (white for BF24-T) in connector 2
- S6** Grey cable colour (white for BF24-T) in connector 2
- Tf** Thermal fuse

Type of activation B24T-SR

IMPORTANT: Risk of electric shock!

Switch off the power supply before working on any electrical equipment.

Only qualified electricians are allowed to work on the electrical system.

Actuator power supply: AC (50/60 Hz)/DC 24 V

NOTES:

- Supply via safety isolation transformer.
- Power consumption must be observed!

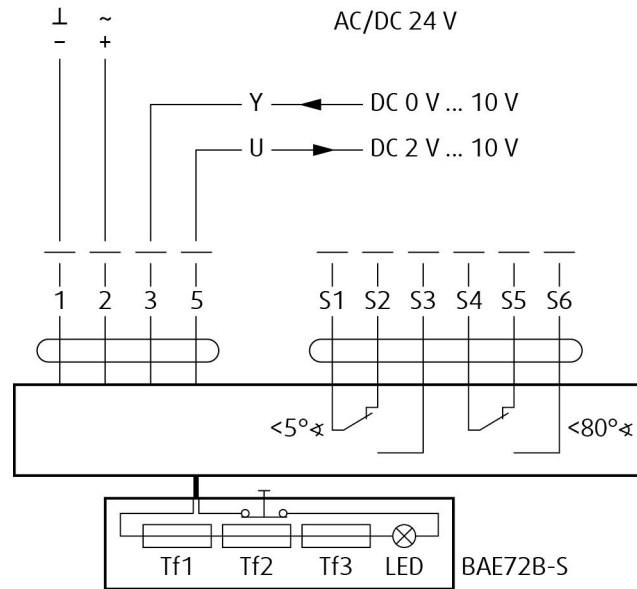

Legend

- 1** Blue cable colour
- 2** Brown cable colour
- 3** White cable colour
- 5** Orange cable colour
- S1** Violet cable colour
- S2** Red cable colour
- S3** White cable colour
- S4** Orange cable colour
- S5** Pink cable colour
- S6** Grey cable colour
- Tf** Thermal fuse

Type of activation G24T-SR

IMPORTANT: Risk of electric shock!

Switch off the power supply before working on any electrical equipment.

Only qualified electricians are allowed to work on the electrical system.

Actuator power supply: AC (50/60 Hz)/DC 24 V

NOTES:

- Supply via safety isolation transformer.
- Power consumption must be observed!

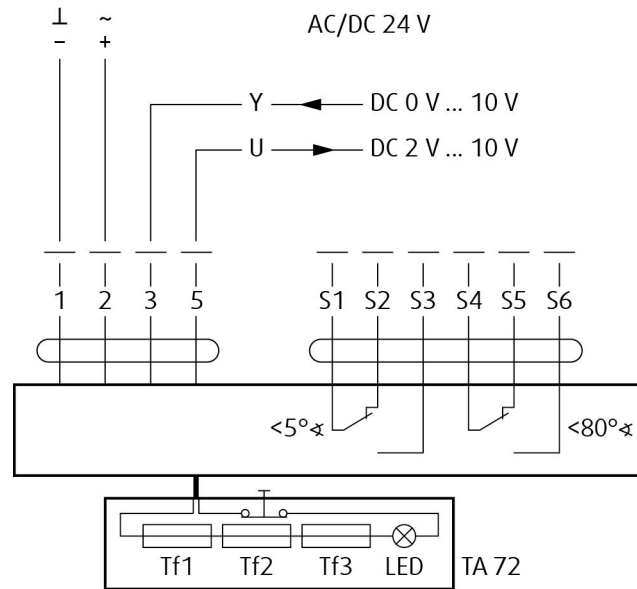

Legend

- 1** Blue cable colour
- 2** Brown cable colour
- 3** Black cable colour
- 4** Grey cable colour
- S1** Violet cable colour
- S2** Red cable colour
- S3** White cable colour
- S4** Orange cable colour
- S5** Pink cable colour
- S6** Grey cable colour
- Tf** Thermal fuse

Operation manual

Warning

To avoid injury, make sure to wear gloves and keep the blades movement area clear while manipulating with the damper.

NEVER OPEN THE INSPECTION LID WHEN THERE IS AIR FLOWING IN THE DUCT CONNECTED TO THE FIRE DAMPER!

Fire Damper Functionality Check

Manually Operated Activation Mechanism

1. Open the damper - turn the red crank (P10) using a hexagon bent wrench No. 10 (P13). Turn the red crank so that the indicator arrow is pointing to the "OPEN" position (P11), the red crank needs to remain in the "OPEN" position, and the microswitch for the open position indication must be pushed (if installed).
2. Close the damper - release the mechanism by pressing the red release button (P9), the red crank will adjust its indicator arrow pointing to the "CLOSED" position (P12) and remain locked in this position, the microswitch for the closed position indication must be pushed (if installed).
3. Open the damper - turn the red crank (P10) using a hexagon bent wrench No. 10. (P13) Turn the red crank so that the indicator arrow is pointing to the "OPEN" position, the red crank needs to remain in the "OPEN" position, and the microswitch for the open position indication must be pushed (if installed).

Spring Return Actuator Operated Activation Mechanism

1. The fire damper must open automatically after the actuator circuit closes - the arrow on the actuator axis must show the position 90°.
2. Press the control switch (P9) on the Thermoelectric fuse and hold it until the fire damper is fully closed - the arrow on the actuator axis must show the position 0°.
3. Release the control switch on the Thermoelectric fuse. The fire damper must become fully open - the arrow on the actuator axis must show the position 90° - which is the operating position.

Operation Manual

After installation, it is necessary to adjust the damper into its operating position - open the fire damper.

Spring Return Actuator Operated Activation Mechanism

Connect the electric driving mechanism to the relevant electric power supply (see Electrical connection section). The electromotor is activated and adjusts the damper into its open position.

Manually Operated Activation Mechanism

Turn the red crank into the "OPEN" position. The damper blade must remain in open position.

Damper Inspection

The activation mechanism keeps the dampers on stand-by during their entire life cycle in accordance with this manual issued by the manufacturer. It is not permitted to alter the dampers in any way nor perform any changes to their structure without the manufacturer's consent. The operator performs regular checks of the dampers as per established regulations and standards at least once every 12 months. The check needs to be performed by an employee who has been specifically trained for this purpose. The current fire damper condition determined during the inspection needs to be entered into the operating logbook along with the date of the inspection, the legible name, surname and signature of the employee who performed the inspection. The Operating Journal includes a copy of the employee's authorization. If any discrepancies are discovered, these need to be entered in the Operating Journal along with a proposal for their removal. The Operating Journal can be found in product documents section. Immediately after the installation and activation of the damper, it needs to be checked under the identical conditions as apply to the above mentioned 12-month inspections. The visual check ensures that visible damages on the inspected damper parts are seen. On its external side, the damper housing and the activation mechanism are checked. Due to the need to perform a visual check of the damper's internal parts, open the inspection lid. For small sizes there is the possibility of removing the mechanism to perform the inspection. The removable mechanism always needs to be replaced into the damper with the damper blade being closed.

The damper's internal casing, thermal fuse, seals, foaming substance, the damper blade condition and accuracy of its closure during its leaning against the backstop in the closed position must all be checked. There must not be any strange objects or a layer of impurities from the air distribution systems inside the damper.

Recommended Inspection Steps According to the EN 15 650:

1. Damper identification
2. Date of inspection
3. Inspecting electric connection of the activation mechanism (where applicable)
4. Inspecting damper for cleanliness and possible need for cleaning (where needed)
5. Inspecting blade and sealing condition, possible correction and logging (where needed)
6. Inspecting proper fire damper closure
7. Inspecting damper functionality – opening and closing using the control system, physical examination of the damper's behavior, possible correction and logging (where needed)
8. Inspecting end switches' functionality in the open and closed position, possible correction and logging (where needed)
9. Inspect whether the damper is fulfilling its role as part of the regulation system (where needed)
10. Inspect whether the damper remains in its standard operating position.
11. The damper is usually part of a system. In that case the whole system needs to be checked as described in its operation and requirements published by the builder of the system.

Supplement

Any deviations from the technical specifications contained in SystemairDESIGN and the terms should be discussed with the manufacturer. We reserve the right to make any changes to the product without prior notice, provided that these changes do not affect the quality of the product and the required parameters.

