

FDS-3G...KS

Fire Damper FDS-3G with Kit-S

Handbook



Table of Contents

Overview	3
Technical Parameters	6
Diagrams	11
Dimensions & Weights	13
Ordering Code	16
Installation	18
Electrical Parameters	25
Operation Manual	54

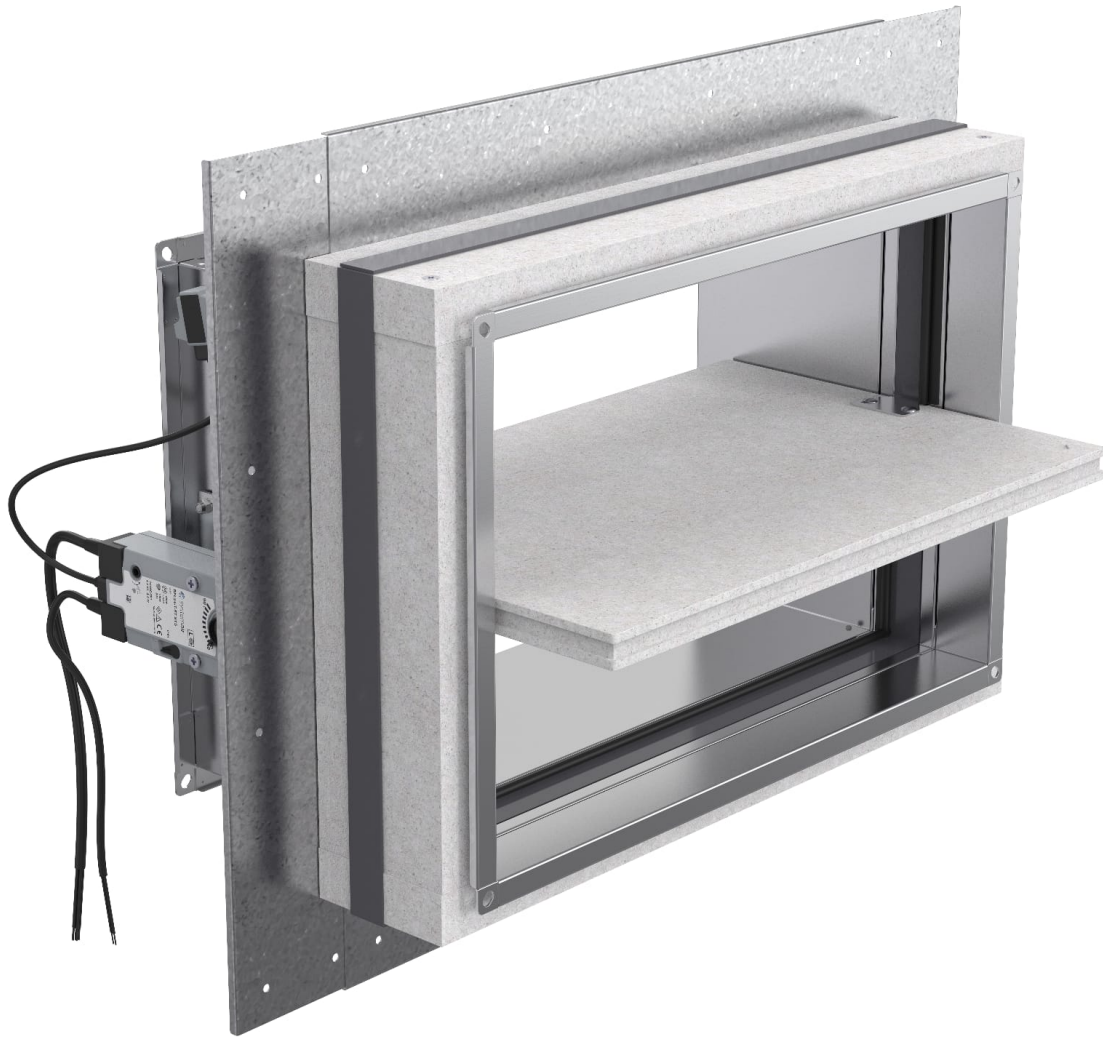

Description

Fire dampers with square Kit up to size 800x600 mm represent passive fire protection, designed with the help of compartmentalization to prevent the spread of toxic gases, smoke and fire. FDS-3G...KS fire dampers installation is designed with simplicity in mind. Standard fire dampers are designed and certified in accordance with EN 15650 and tested for EIS criteria according to EN 1366-2. By default, all fire dampers are supplied with an manual mechanism or actuator mechanism, optionally with a supply and communication unit.

IMPORTANT: The installation kit can not be delivered separately! The installation kit is delivered pre-mounted on a damper.

Design

Fire dampers have casings made from galvanized sheet metal. Blades from non-asbestos insulants have a rubber seal for cold smoke and an intumescent seal, that expands in a fire situation.

Material Composition

IMPORTANT: The installation kit can not be delivered separately! The installation kit is delivered pre-mounted on a damper.

Highlights

- Fast installation rated EI60S, EI90S, EI120S
- Casing tightness class C as standard
- Exceptionally low pressure drop
- Changeable mechanism
- Two inspection openings for all sizes greater than 200x200 mm
- Modulated actuator suitable for system balancing - possibility to open the blade at the desired angle.

Activation Types

Manually Operated Fire Dampers

By default, all manually operated fire dampers are supplied with manual control, optionally with micro switches and electromagnets. In case of fire, the fire damper is closed automatically. Depending on the version, the damper closes either after the melting of the thermal fuse or by means of remote activation through an electromagnet in impulse connection. After the closing of the damper blade, it is mechanically locked in the closed position and can only be opened manually. The actuating mechanism is activated when the temperature of the air in the duct reaches 74°C and the damper closes within 10 seconds after the melting of the fuse.

- H0-KS

Fire damper with an activation mechanism with a cover, manual crank and with a spring return release mechanism activated by a fusible thermal link set to 74°C (on demand 100°C).

- H2-KS

Fire damper with an activation mechanism H0 + open and closed indication with AC 230 V or AC/DC 24 V contact switches.

- H5-2-KS

Fire damper with an activation mechanism H0 + a AC/DC 24 V electromagnetic release mechanism in the impulse connection (release takes place when the electromagnet is activated) + open and closed indication with AC 230 V or AC/DC 24 V contact switches.

- H6-2-KS

Fire damper with an activation mechanism H0 + an AC 230 V electromagnetic release mechanism in the impulse connection (release takes place when the electromagnet is activated) + open and closed indication with AC 230 V or AC/DC 24 V contact switches.

Actuator- Operated Fire Dampers

By default, all actuator operated fire dampers are supplied with an actuator with micro switches, optionally with a power and communication unit. A fire damper can be equipped with a spring return actuator can be closed with command from the building management system, or after the breaching of the thermoelectric fuse. Actuator operated fire dampers are standardly equipped with a thermoelectric fuse, that activates the closing of the damper after the reaching or exceeding of the ambient temperature of 72°C. The actuator power circuit is interrupted and its spring closes the damper blade within 20 seconds.

Belimo actuator available with on demand fuse 95 °C or 120 °C.

- B230T or G230T

Fire damper with an activation mechanism with a Belimo or Gruner spring return actuator (230V AC) with electro-thermal fuse 72°C and auxiliary switches.

- B24T or G24T

Fire damper with an activation mechanism with a Belimo or Gruner spring return actuator (24V AC/DC) with electro-thermal fuse 72°C and auxiliary switches.

- GST0

Fire damper with an activation mechanism with a Gruner spring return actuator (24V AC/DC) with an electro-thermal fuse 72°C and auxiliary switches, with a Gruner supply and communication unit fs-UFC24-2 (other communication units on demand).

- B24T-W or G24T-W

Fire damper with an activation mechanism with a Belimo or Gruner spring return actuator (24V AC/DC) with an electro-thermal fuse 72°C and auxiliary switches, with provided cable connectors for the supply and communication unit (communication unit not part of the mechanism).

- B24T-SR or G24T-SR

Fire damper with an activation mechanism with a Belimo or Gruner spring return actuator (24V AC/DC) with electro-thermal fuse 72°C and auxiliary switches for Modulated dampers (possibility to open the blade at the desired angle). For fire dampers in the size $H \geq 160$ mm. Not available for FDS-EI90S/EI120S.

Design

The product contains galvanized sheet metal, calcium silicate board, fireproof carbon fiberglass, polyurethane foam and ethylene - propylene rubber. These are processed in accordance with local regulations. The product contains no hazardous substances, except for the solder in the thermofuse, which contains a milligram of lead.

List of Accessories

Detailed information about accessories for FDS-3G...KS is available in SystemairDESIGN under Fire Damper Accessories.

- AM-FD: Activation Mechanisms

Technical Parameters

Durability test

- 50 cycles/manually operated activation mechanism – with no change of the required properties
- 10000 + 100 + 100 cycles/actuator operated activation mechanism – with no change of the required properties
- 20 000 cycles/modulated actuator (B24T-SR-KS and G24T-SR-KS) – with no change of the required properties

Fire testing pressure

Underpressure up to 300 Pa

Safety position

Closed. (In fire scenario the damper closes via spring in actuator or spring in manual mechanism)

Airflow direction

Both directions

Allowed air velocity

Damper can still operate at max. 12 m/s. Air without any mechanical or chemical contamination

Side with fire protection

Depending on installation classification: From both sides (i <-> o)

Repeated opening

Suitable for daily check procedure. It is not possible to operate the device after reaching Activation temperature.

Activation Temperature

- Manually operated: 74 °C as standard (100 °C on request) by means of a spring after the melting of the thermofuse.
- Actuator operated: 72 °C as standard (95 °C or 120 °C on request) by means of the spring after current interruption in the electro-thermal fuse.

Operational temperature

- Minimum: 0 °C
- Maximum: 60 °C for 74 °C and 72 °C thermofuse
- Maximum: 85 °C for 95 °C and 100 °C thermofuse
- Maximum 105 °C for 120 °C thermofuse

Environment suitability

Protected against weather disruptions, with temperature above 0 °C, up to 95% Rha, (3K5 according to EN 60721-3-3)

Open/Closed indication

- Manually operated microswitches - Activation types H2-KS up to H6-2-KS
- Actuator operated built-in microswitches - Activation types B230T-KS/G230T-KS up to B24T-SR-KS/G24T-SR-KS

Closing/Opening time

Manually operated < 10 s, actuator operated < 20 s

Inspection possibility

By opening of the inspection lid. For smaller sizes than 200 mm after removing of the activation mechanism, or a inspection opening must be added to the connected duct.

Maintenance

Not required. Dry cleaning if demanded by law in the country in which the dampers are installed.

Revisions

Determined by law in the country in which the fire dampers are installed but at least every 12 months.

Allowed pressure

1200 Pa

Blade tightness (STN EN 1751)

Class 2 as standard

Tightness of the housing (STN EN 1751)

Class C as standard

Conformity with EC directives

2006/42/EC Machinery Directive

2014/35/EU Low Voltage Directive

2014/30/EU Electromagnetic Compatibility Directive

Modulated Actuator

Can be set to any position when opening the blade - see types of activation mechanisms B24T-SR-KS/G24T-SR-KS

Driving actuator types

Belimo: BLF230-T, BLF24-T, BFL24-SR-T, BF230-T, BF24-T, BF24-SR-T, BFN230-T, BFN24-T, BFN24-T, BFL230-T, BFL24-T, BFL24-SR-T (also with connection possibilities with acronyms ST, W)

Gruner: 360TA-230-12-S2, 360CTA-024-12-S2, 360TA-024-12-S2, 340TA-230D-03-S2, 340TA-024D-03-S2, 340CTA-024D-03-S2, 340TA-230-05-S2, 340TA-024-05-S2, 340CTA-024-05-S2 (also with connection possibilities with acronyms ST, W)

Transport and Storage

Dry indoor conditions with a temperature range of -20 °C to +50 °C

[Product parts](#)

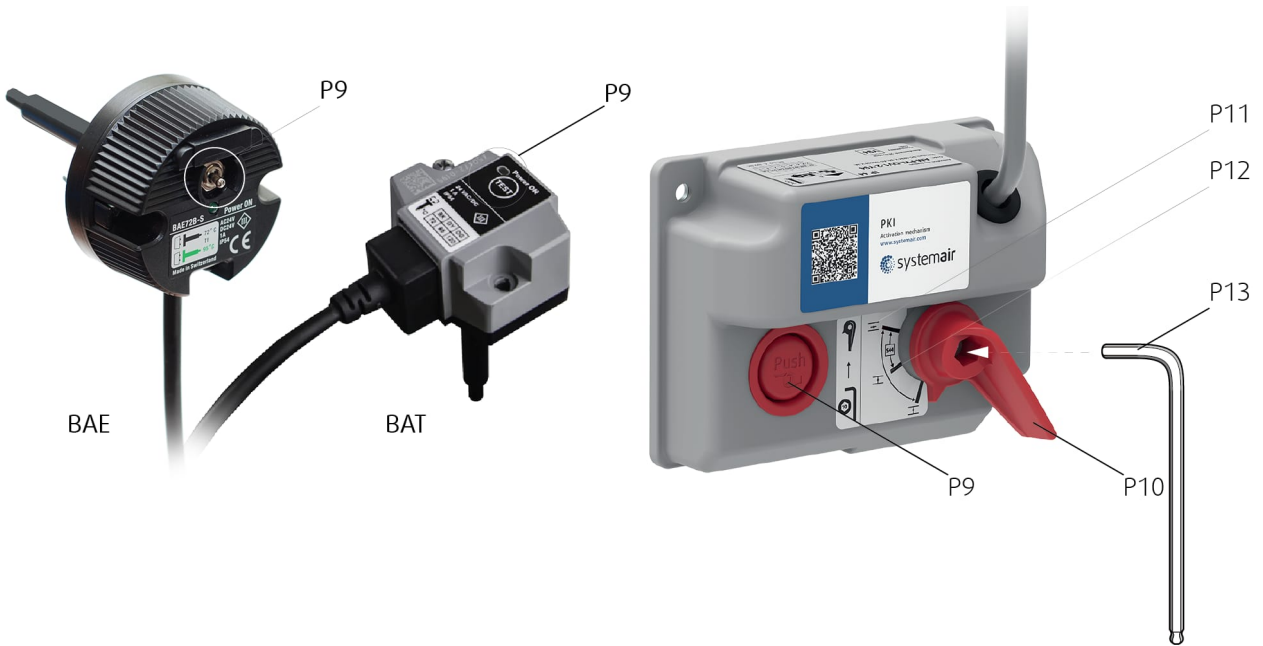
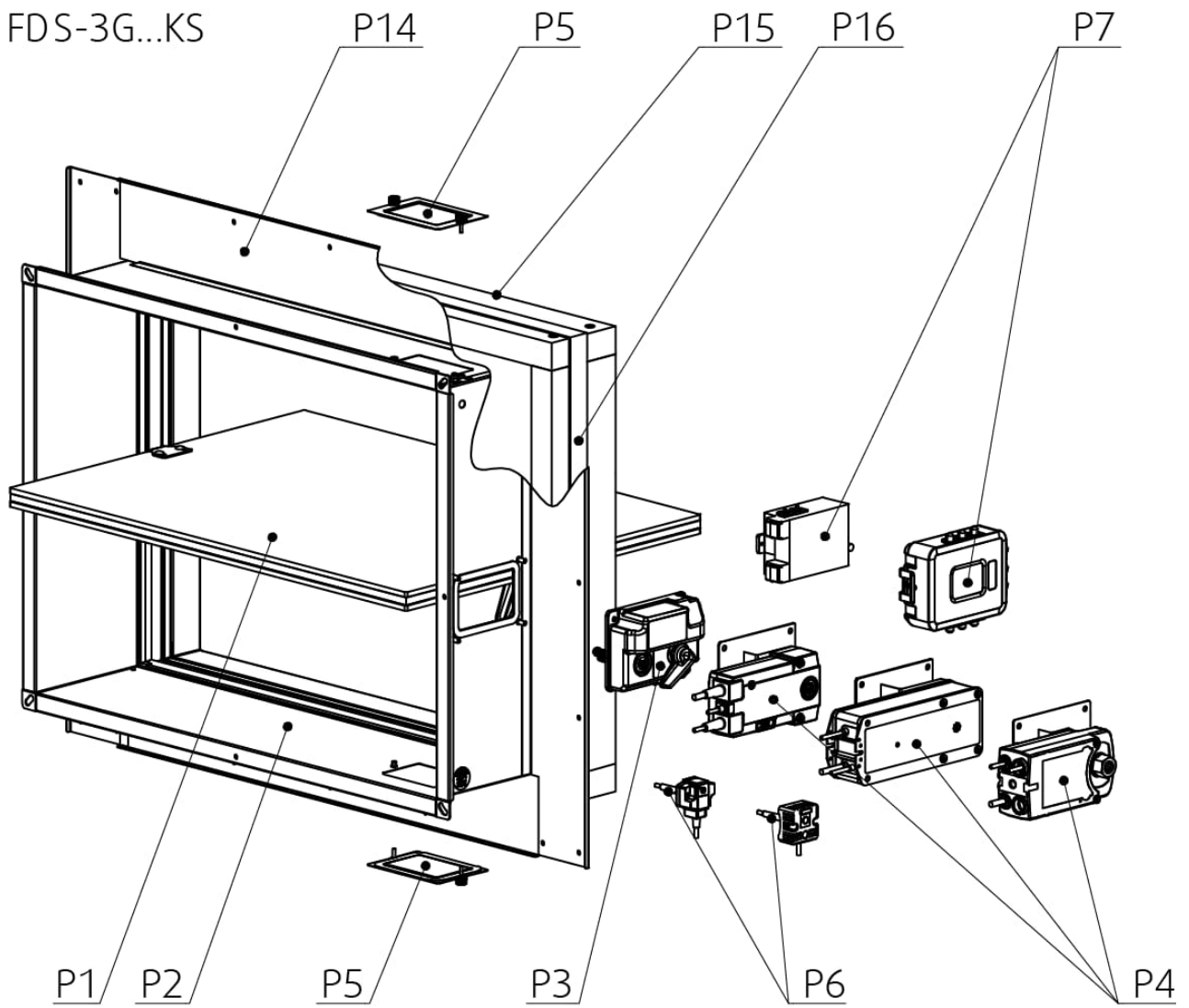

Legend

- P1 Blade
- P2 Casing
- P3 Manually operated activation mechanism (H0;H...)

- P4** Actuator operated activation mechanism (B...;G...)
- P5** Inspection lid
- P6** Thermoelectric fuse (BAT72;TA-72)
- P7** Supply and communication unit (BKN230-24;FS-UFC24-2)
- P9** Release and test button
- P10** Crank
- P11** Open position
- P12** Closed position
- P13** Hexagon bent wrench No.10 (not part of delivery)
- P14** Kit Base plate
- P15** Cover plate (PROMAT)
- P16** Intumex

Assessed Performance - FDS-3G

19 CE 1396

Systemair Production a.s.

Hlavná 371, 900 43 Kalinkovo, Slovakia

1396-CPR-0163, FDS-3G

(valid for subgroups: ...EX, ...KS, ...OF)

EN 15650 : 2010

Rectangular fire dampers

Nominal activation conditions/sensitivity		Pass
<ul style="list-style-type: none"> • sensing element load bearing capacity • sensing element response temperature 		
Response delay (response time)		Pass
<ul style="list-style-type: none"> • closure time 		
Operational reliability		Pass
<ul style="list-style-type: none"> • motorized cycle • manual cycle • modulated 	<p>10.200 cycles</p> <p>50 cycles</p> <p>20.200 cycles</p>	
Fire resistance:		
Resistivity depending on installation method and situation		
<ul style="list-style-type: none"> • integrity E • maintenance of the cross section (under E) • mechanical stability (under E) • cross section (under E) • insulation I • smoke leakage S 		
Durability of response delay		Pass
<ul style="list-style-type: none"> • sensing element response temperature and load bearing capacity 		
Durability of operational reliability		Pass
<ul style="list-style-type: none"> • open and closing cycle 		

Diagrams

The pressure drop and A-weighted total discharged sound power level depend on the nominal width and height of the damper and air flow volume at different duct pressures. The type of activation does not influence the airflow parameter, therefore only one activation type is shown in the diagrams.

FDS-3G-...-KS

Pressure drop & A-weighted sound power level in dB(A)

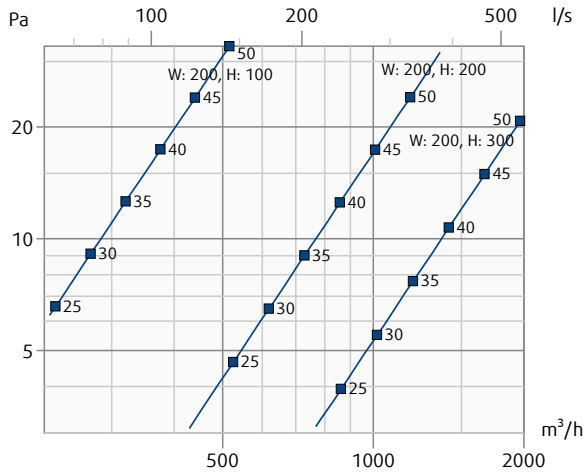

FDS-3G-...-KS

Pressure drop & A-weighted sound power level in dB(A)

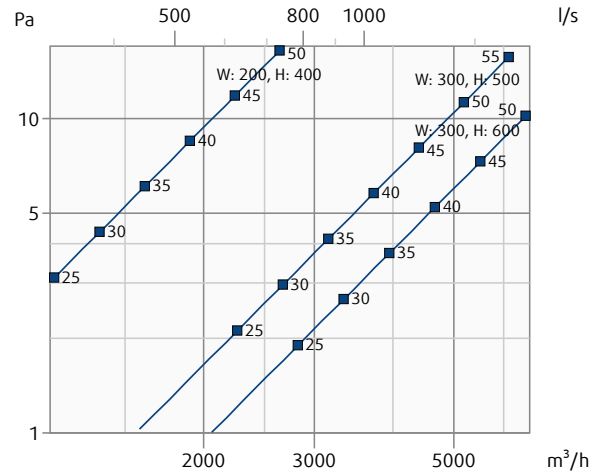

FDS-3G-...-KS

Pressure drop & A-weighted sound power level in dB(A)

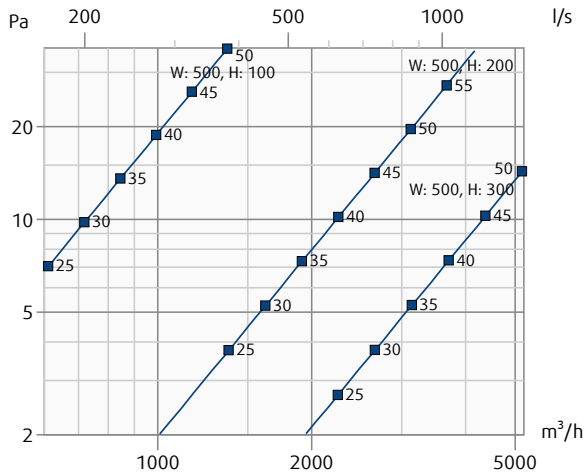

FDS-3G-...-KS

Pressure drop & A-weighted sound power level in dB(A)

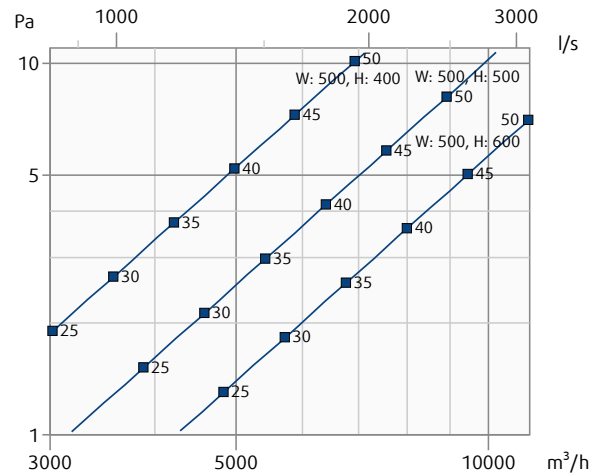

FDS-3G-...-KS

Pressure drop & A-weighted sound power level in dB(A)

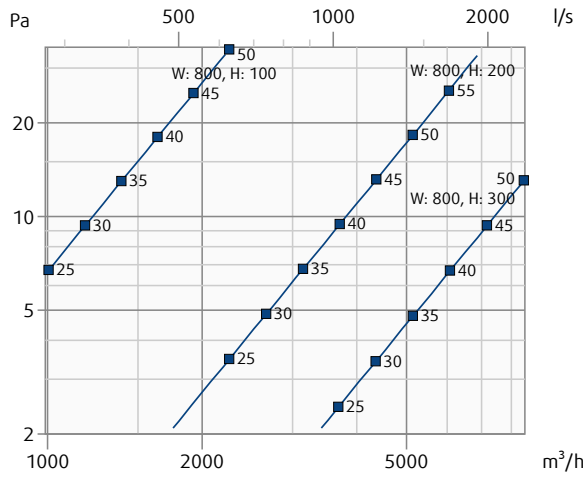

FDS-3G-...-KS

Pressure drop & A-weighted sound power level in dB(A)

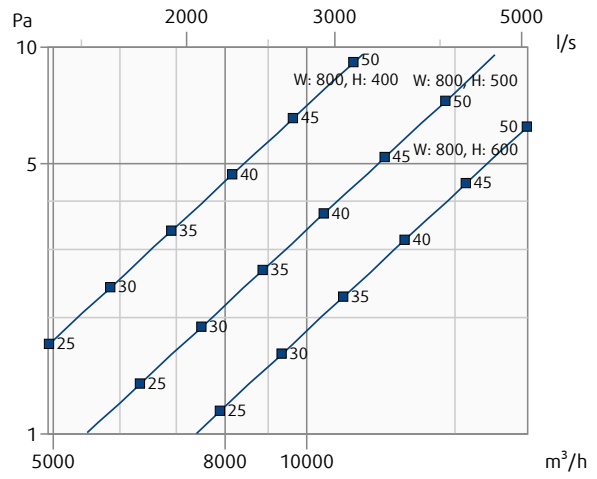

Free area

A _v (m ²)		W (mm)																			
		100	150	200	250	300	315	350	355	400	450	500	550	560	600	630	650	700	710	750	800
H (mm)	100	0,007	0,010	0,014	0,018	0,022	0,023	0,026	0,026	0,030	0,030	0,034	0,037	0,038	0,041	0,043	0,044	0,048	0,049	0,051	0,055
	150	0,011	0,015	0,021	0,027	0,033	0,034	0,038	0,039	0,044	0,047	0,052	0,058	0,059	0,063	0,066	0,068	0,074	0,075	0,079	0,085
	175	0,013	0,019	0,026	0,033	0,040	0,042	0,047	0,048	0,054	0,058	0,064	0,071	0,072	0,078	0,082	0,084	0,091	0,092	0,098	0,104
	180	0,014	0,019	0,027	0,034	0,041	0,043	0,048	0,049	0,056	0,060	0,067	0,074	0,075	0,081	0,085	0,087	0,094	0,096	0,101	0,108
	200	0,016	0,022	0,030	0,039	0,047	0,049	0,055	0,056	0,063	0,067	0,074	0,082	0,084	0,090	0,095	0,098	0,105	0,107	0,113	0,121
	250	-	0,029	0,040	0,050	0,061	0,064	0,072	0,073	0,083	0,088	0,099	0,109	0,111	0,119	0,125	0,129	0,140	0,142	0,150	0,160
	300	-	0,036	0,049	0,062	0,075	0,079	0,089	0,090	0,102	0,110	0,123	0,135	0,138	0,148	0,156	0,161	0,174	0,176	0,186	0,199
	315	-	-	0,052	0,066	0,080	0,084	0,094	0,095	0,108	0,116	0,130	0,143	0,146	0,157	0,165	0,170	0,184	0,187	0,197	0,211
	350	-	-	0,058	0,074	0,090	0,094	0,105	0,107	0,121	0,132	0,147	0,162	0,165	0,177	0,186	0,193	0,208	0,211	0,223	0,238
	355	-	-	0,059	0,075	0,091	0,096	0,107	0,109	0,123	0,134	0,149	0,165	0,168	0,180	0,190	0,196	0,211	0,214	0,227	0,242
	400	-	-	-	0,086	0,104	0,109	0,122	0,124	0,140	0,153	0,171	0,189	0,192	0,206	0,217	0,224	0,242	0,245	0,260	0,277
	450	-	-	-	0,094	0,114	0,120	0,134	0,136	0,154	0,175	0,195	0,215	0,219	0,235	0,248	0,256	0,276	0,280	0,296	0,316
	500	-	-	-	0,105	0,128	0,135	0,151	0,153	0,174	0,196	0,219	0,242	0,246	0,265	0,278	0,287	0,310	0,315	0,333	0,356
	550	-	-	-	-	0,142	0,15	0,167	0,170	0,193	0,218	0,243	0,268	0,273	0,294	0,309	0,319	0,344	0,349	0,369	0,395
	560	-	-	-	-	0,145	0,153	0,171	0,173	0,197	0,222	0,248	0,274	0,279	0,300	0,315	0,325	0,351	0,356	0,377	0,403
	600	-	-	-	-	0,156	0,165	0,184	0,187	0,212	0,240	0,267	0,295	0,301	0,323	0,339	0,351	0,378	0,384	0,406	0,434

Dimensions

Dimensions

To avoid blocking the movement of a damper blade, connect a straight duct at minimal lengths respectively R1 or R2. R1 and R2 are the overhang of the fully open blade, including seals and gaskets on the damper blade.

NOTES

* For nominal size W = 100 mm the internal width dimension is 100 mm, flange outside width dimension 152 mm and/or for nominal size H = 100 mm the internal height dimension is 100 mm, flange outside height dimension 152 mm.

{dimensions}

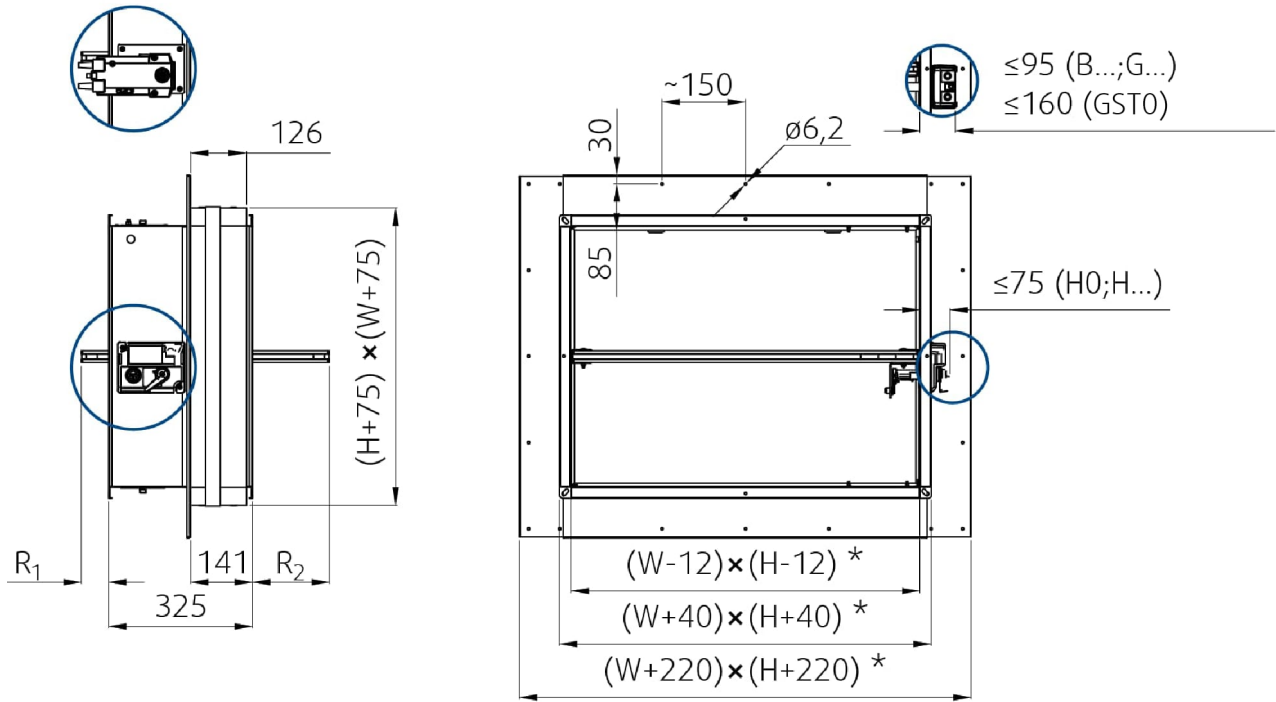

{dimensions}

	H (mm)															
	100	150	175	180	200	250	300	315	350	355	400	450	500	550	560	600
R1 (mm)	-188	-163	-150	-148	-143	-118	-93	-85	-68	-65	-43	-18	7	32	37	57
R2 (mm)	-43	-18	-5	-3	2	27	52	60	77	80	102	127	152	177	182	202

Weights

m (kg ±10%)		W (mm)																			
		100	150	200	250	300	315	350	355	400	450	500	550	560	600	630	650	700	710	750	800
H (mm)	100	7,1	7,9	8,8	9,6	10,5	10,8	11,4	11,5	12,3	13,2	14,0	14,9	15,1	15,8	16,3	16,5	17,6	17,8	18,4	19,3
		9,1	9,9	10,8	11,6	12,5	12,8	13,4	13,5	14,3	15,2	16,0	16,9	17,1	17,8	18,3	18,5	19,6	19,8	20,4	21,3
	150	7,9	8,8	9,7	10,7	11,7	11,9	12,6	12,7	13,5	14,5	15,4	16,3	16,5	17,4	17,9	18,1	19,2	19,4	20,1	21,0
		9,9	10,8	11,7	12,7	13,7	13,9	14,6	14,7	15,5	16,5	17,4	18,3	18,5	19,4	19,9	20,1	21,2	21,4	22,1	23,0
	200	8,8	9,8	10,7	11,8	12,8	13,1	13,8	13,9	14,8	15,8	16,8	17,9	18,0	18,9	19,4	19,6	20,9	21,1	21,8	22,8
		10,8	11,8	12,7	13,8	14,8	15,1	15,8	15,9	16,8	17,8	18,8	20,9	20,0	20,9	21,4	21,6	22,9	24,1	24,8	24,8
	250	-	11,7	11,8	12,9	13,9	14,2	15,0	15,2	16,0	17,2	18,3	19,4	19,6	20,4	21,0	21,2	22,5	22,7	23,6	24,7
		-	13,7	13,8	14,9	15,9	16,2	17,0	17,2	18,0	19,2	20,3	21,4	21,6	22,4	23,0	23,2	24,5	24,7	25,6	26,7
	300	-	-	12,8	13,9	15,0	15,4	16,2	16,4	17,3	18,6	19,7	20,8	21,0	21,9	22,6	22,7	24,1	24,4	25,4	26,5
		-	-	14,8	15,9	17,0	17,4	18,2	18,4	19,3	20,6	21,7	22,8	23,0	23,9	24,6	24,7	26,1	26,4	27,4	28,5
	315	-	-	13,1	14,2	15,4	15,8	16,6	16,7	17,7	18,9	20,1	21,2	21,5	22,3	23,1	23,3	24,7	24,9	25,9	27,0
		-	-	15,1	16,2	17,4	17,8	18,6	18,7	19,7	20,9	22,1	23,2	23,5	24,3	25,1	25,3	26,7	26,9	27,9	29,0
	350	-	-	13,8	15,0	16,2	16,6	17,3	17,5	18,6	19,9	21,1	22,2	22,5	23,4	24,2	24,3	25,9	26,0	27,1	28,3
		-	-	15,8	17,0	18,2	18,6	19,3	19,5	20,6	21,9	23,1	24,2	24,5	25,4	26,2	26,3	27,9	28,0	29,1	30,3
	355	-	-	13,9	15,2	16,4	16,7	17,5	17,6	18,7	20,0	21,2	22,4	22,6	23,6	24,3	24,5	26,0	26,3	27,2	28,4
		-	-	15,9	17,2	18,4	18,7	19,5	19,6	20,7	22,0	23,2	24,4	24,6	25,6	26,3	26,5	28,0	28,3	29,2	30,4
	400	-	-	14,8	16,0	17,3	17,7	18,6	18,7	19,9	21,2	22,4	23,7	24,0	24,9	25,7	25,9	27,5	27,8	28,8	30,0
		-	-	16,8	18,0	19,3	19,7	20,6	20,7	21,9	23,2	24,4	25,7	26,0	26,9	27,7	27,9	29,5	29,8	30,8	32,0
	450	-	-	-	17,1	18,5	18,9	19,8	19,9	21,1	22,5	23,8	25,1	25,4	26,5	27,3	27,5	29,2	29,5	30,5	31,8
		-	-	-	19,1	20,5	20,9	21,8	21,9	23,1	24,5	25,8	27,1	27,4	28,5	29,3	29,5	31,2	31,5	32,5	33,8
500	-	-	-	18,2	19,6	20,0	21,0	21,1	22,4	23,8	25,2	26,7	26,9	28,1	28,8	29,0	30,8	31,1	32,2	33,6	
	-	-	-	20,2	21,6	22,2	23,0	23,1	24,4	25,8	27,2	28,7	28,9	30,1	30,8	31,0	32,8	33,1	34,2	35,6	
550	-	-	-	-	20,7	21,1	22,2	22,4	23,6	25,1	26,7	28,1	28,4	29,6	30,4	30,6	32,5	32,8	33,9	35,4	
	-	-	-	-	22,7	23,1	24,2	24,4	25,6	27,1	28,7	30,1	30,4	31,6	32,4	32,6	34,5	34,8	35,9	38,4	
560	-	-	-	-	21,0	21,4	22,4	22,5	23,9	25,4	26,7	28,4	28,6	29,9	30,7	30,9	32,8	33,1	34,3	35,7	
	-	-	-	-	23,0	23,4	24,4	24,5	25,9	27,4	28,7	30,4	30,6	31,9	32,7	32,9	34,8	35,1	36,3	37,7	
600	-	-	-	-	21,8	22,3	23,3	23,6	24,9	26,5	28,1	29,6	29,9	31,1	32,0	32,1	34,1	34,4	35,7	37,2	
	-	-	-	-	23,8	24,3	25,3	25,6	26,9	28,5	30,1	31,6	31,9	33,1	34,0	34,1	36,1	37,4	37,7	39,2	

FDS-3G...KS (H...)
FDS-3G...KS (B..., G...)

Ordering Code

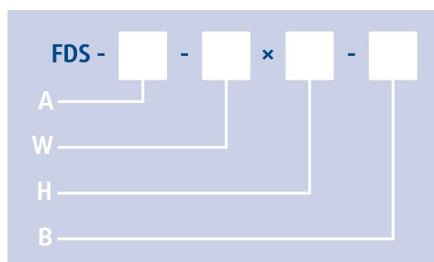

A - Damper type

3G

W - Width Dimension

from 100 mm up to 800 mm

H - Height Dimension

from 100 mm up to 600 mm

B - Type of Activation (H0 up to B24T-SR)

H0-KS (Manual crank, no switches)

H2-KS (Manual crank, 2 switches 230V AC or 24V AC/DC)

H5-2-KS (Manual crank, 24V AC/DC electromagnet, 2 switches 230V AC or 24V AC/DC)

H6-2-KS (Manual crank, 230V AC electromagnet, 2 switches 230V AC or 24V AC/DC)

B230T-KS (230V AC Belimo Actuator)

G230T-KS (230V AC Gruner Actuator)

B24T-KS (24V AC/DC Belimo Actuator)

G24T-KS (24V AC/DC Gruner Actuator)

GST0-KS (24V AC/DC Supply comm.unit & 24V AC/DC Gruner Actuator)

B24T-W-KS (24V AC/DC Belimo Actuator & Wire connector for comm.unit)

G24T-W-KS (24V AC/DC Gruner Actuator & Wire connector for comm.unit)

B24T-SR-KS (24V AC/DC Belimo Actuator, modulated 0..10 V), Only for dimensions ≥ 160 mm

G24T-SR-KS (24V AC/DC Gruner Actuator, modulated 0..10 V), Only for dimensions ≥ 160 mm

Example of the Rectangular Fire Dampers Ordering Code

FDS-3G...KS

FDS-3G-800x600-H2-KS

Rectangular fire damper with Kit, nominal dimensions width \times height = 800 \times 600 mm, with open and closed position indication with 230 V contact microswitches.

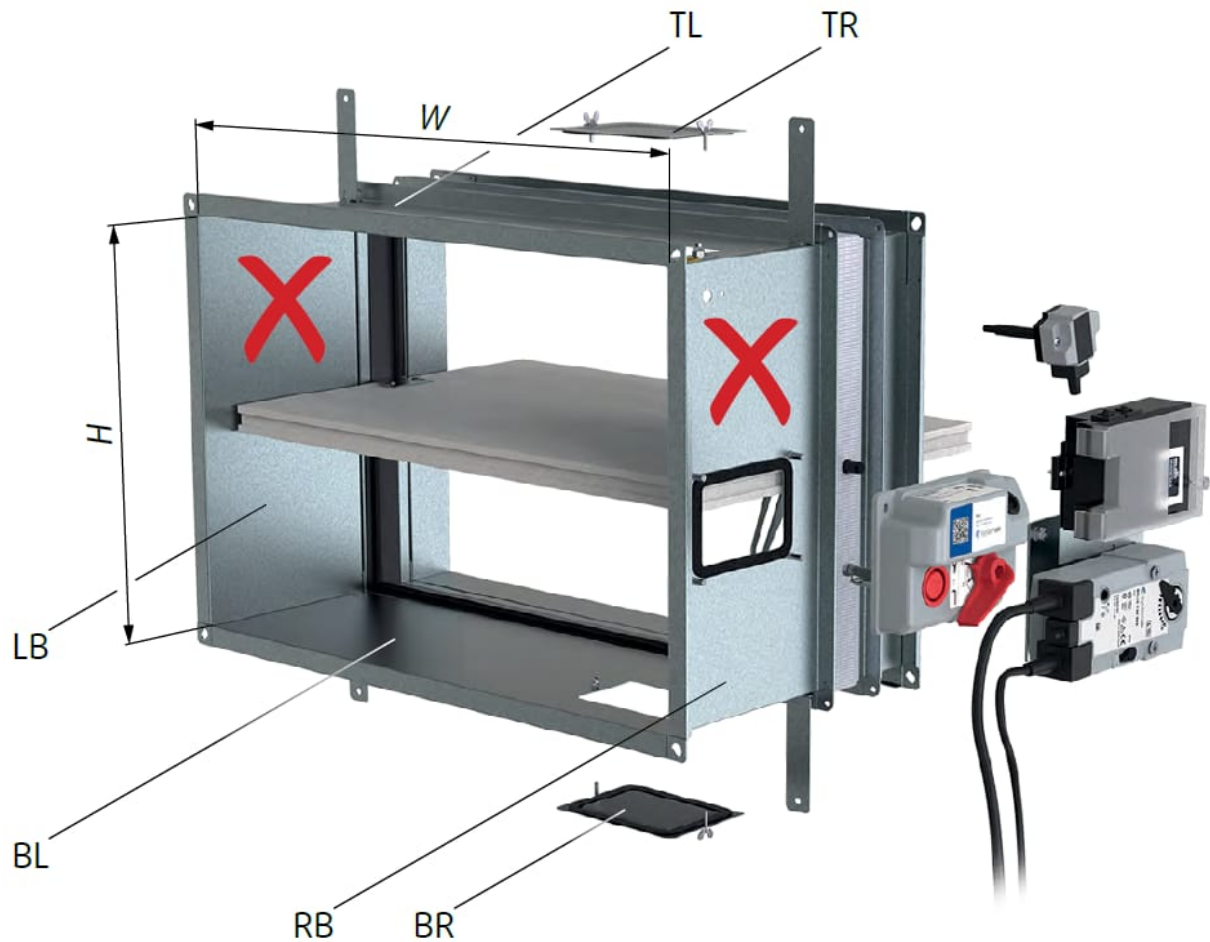

Inspection opening possitions

(Removable mechanism is available for all sizes)

W and $H < 200$

No inspection opening. Inspection possible through removable mechanism or additional inspection opening must be added to the connecting duct.

W and $H \geq 200$

Standardardly in position: BR and TR; On demand in positions: TL*, BL.





$H \geq 250$

Standardardly in position: BR, TR; On demand in position: TL*, LB, BL.

NOTES:

* An inspection lid cannot be placed on position BR and BL on one damper.** An inspection lid cannot be placed on position TL and TR on one damper.

Installation Methods

 4 Kit	FDS-3G...KS	EI 60 (v_e i ↔ o) S	 a)	 b)	 360°
	100 × 100 ...	EI 90 (v_e i ↔ o) S			
	... 800 × 600	EI 120 (v_e i ↔ o) S			

Legend:

4. Kit - Kit Installation, using an Installation Kit

a) - Flexible (plasterboard) wall

b) - Concrete/masonry/cellular concrete (rigid) wall

v_e - Vertical wall

Installation, Maintenance & Operation

Some damper parts may have sharp edges – therefore to protect yourself from harm, please use gloves during damper installation and manipulation. In order to prevent electric shock, fire or any other damage which could result from incorrect damper usage and operation, it is important to:

1. ensure that installation is performed by a trained person.
2. follow the written and depicted instructions provided within Handbook closely.
3. perform damper inspection in accordance with Handbook.
4. check the damper's functionality as per the chapter "Fire Damper Functionality Check" before you install the fire damper. This procedure prevents the installation of a damper that has been damaged during transportation or handling.

Information about installation, maintenance and operation is available in the "Handbook_FDR-3G" document or more can be found at SystemairDESIGN.

Installation rules

- The duct connected to the fire damper must be supported or hung in such a way that the damper does not carry its weight. The damper must not support any part of the surrounding construction or wall which could cause damage and consequent damper failure. It is recommended to connect the damper to a dilatation compensator on either end of the damper.
- The damper driving mechanism can be placed on either side of the wall, however it needs to be placed so as to ensure easy access during inspection.
- The distance between the fire damper bodies is defined by the Kit base plate. Smallest distance between two dampers with kit is when the Kit base plates are touching.
- The distance between the wall/ceiling is defined by the Kit base plate. Smallest distance between wall/ceiling and a damper with kit is when the Kit base plates is touching wall/ceiling.
- The fire damper must be installed into a fire partition structure in such a way that the damper blade in its closed position is located inside this structure. Kit base plate on the damper body represents a plane where supporting constructure begins.
- For each resistivity the minimum thickness of a its supporting construction cannot be decreased as per EN 1366-2 at least 200 mm from the installation opening.

IN ACCORDANCE WITH EN 15650, EACH FIRE DAMPER MUST BE INSTALLED ACCORDING TO THE INSTALLATION INSTRUCTIONS PROVIDED BY THE MANUFACTURER!

Installation 4 - Kit

Installation Using an Installation Kit

IMPORTANT: The installation kit can not be delivered separately! The installation kit is delivered pre-mounted on a damper.





1. The supporting construction opening must be prepared as depicted. Opening surfaces must be even and cleaned off.
2. The opening dimensions are driven by the nominal dimensions of the damper with added clearance. For rectangular dampers, the opening will have dimensions of $W1 \times H1$.
3. The flexible wall opening must be reinforced as per the standards for plasterboard walls. Additionally opening in the flexible wall must be reinforced as per the standards for plasterboard walls and the perimeter of its interior must be lined with a double layer of 12,5 mm thick plasterboard (see detail).
4. This is the simplest installation method. Insert the damper into the opening and fix the Kit base plate using appropriate screws (recommended screw diameter 5,5 - e.g. DIN7981) into pre-drilled holes.
5. If needed, uncover and clean the damper after installation.
6. Check the damper's functionality

Installation Standard Distances

The distances are defined by the kit base plate. Minimum distances are when kit base plate is touching ceiling or side wall. This means from the wall or ceiling to the duct axis it is $(W+230)/2$ or $(H+230)/2$. For multiple crossings through a fire resistive wall the minimum distance between two duct axes is W_p , this means the Kit base plates are touching. This Kit base plate also serves as a distance limiter for nearby foreign objects crossing the fire resistive wall.

Installation into a Wall thinner than tested

Installation into a thinner wall is allowed under the condition that an additional layer/layers of fire protective board are fixed to the surface of the wall in order to achieve the same length of damper penetration seal as was tested. The minimum width of added boards around the damper is 200 mm. In addition, the alternative thinner wall should be classified in accordance with EN 13501-2:2007 + A1: 2009 for fire resistance required for product application. For a protruding wall, the additional layers must be fixed on the steel supporting construction of the wall.

 4 Kit	FDS-3G...KS 100 × 100 800 × 600	EI 60 ($v_e i \leftrightarrow o$) S	a) 	b) 	 360°
		EI 90 ($v_e i \leftrightarrow o$) S			
		EI 120 ($v_e i \leftrightarrow o$) S			

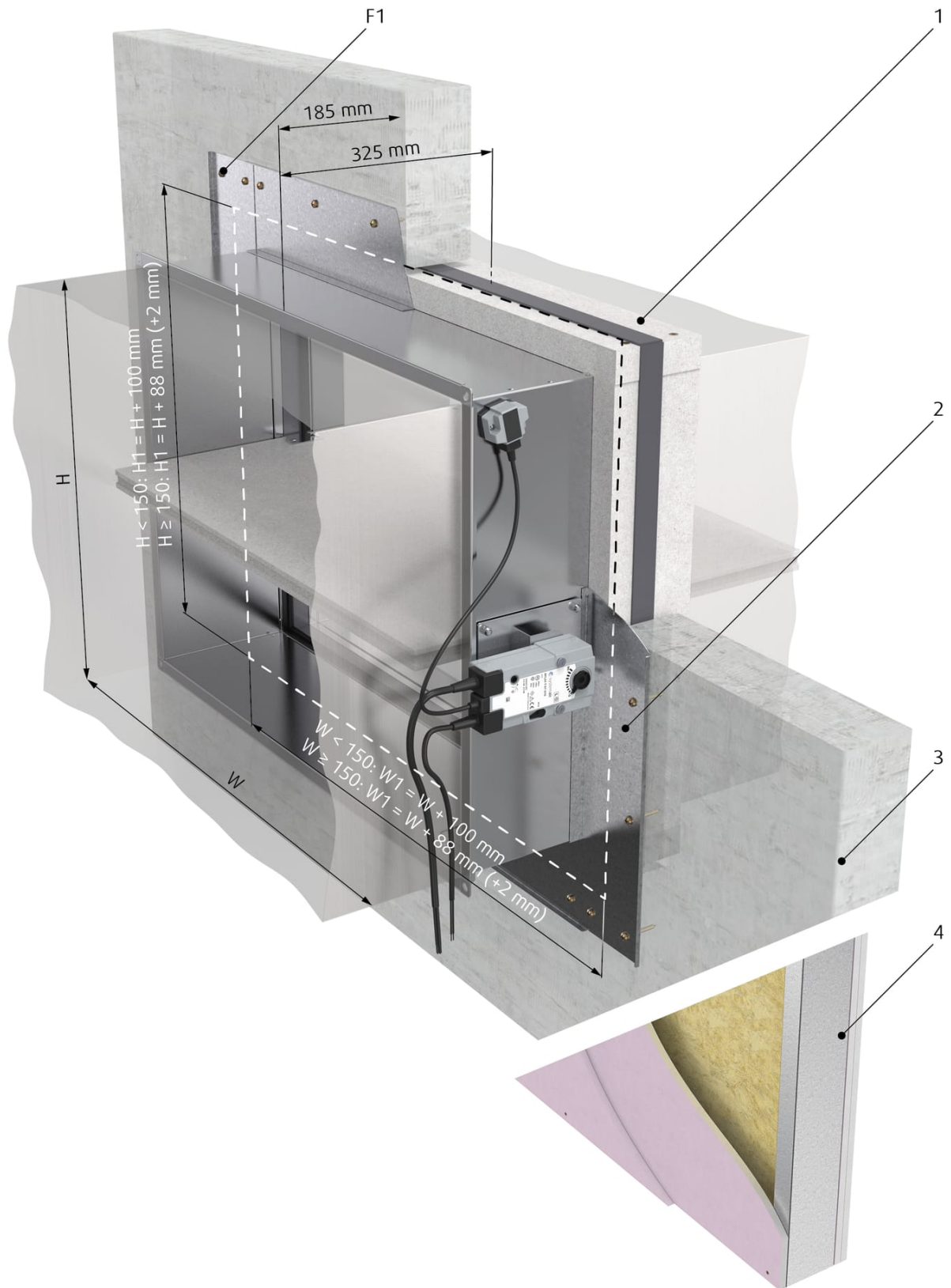

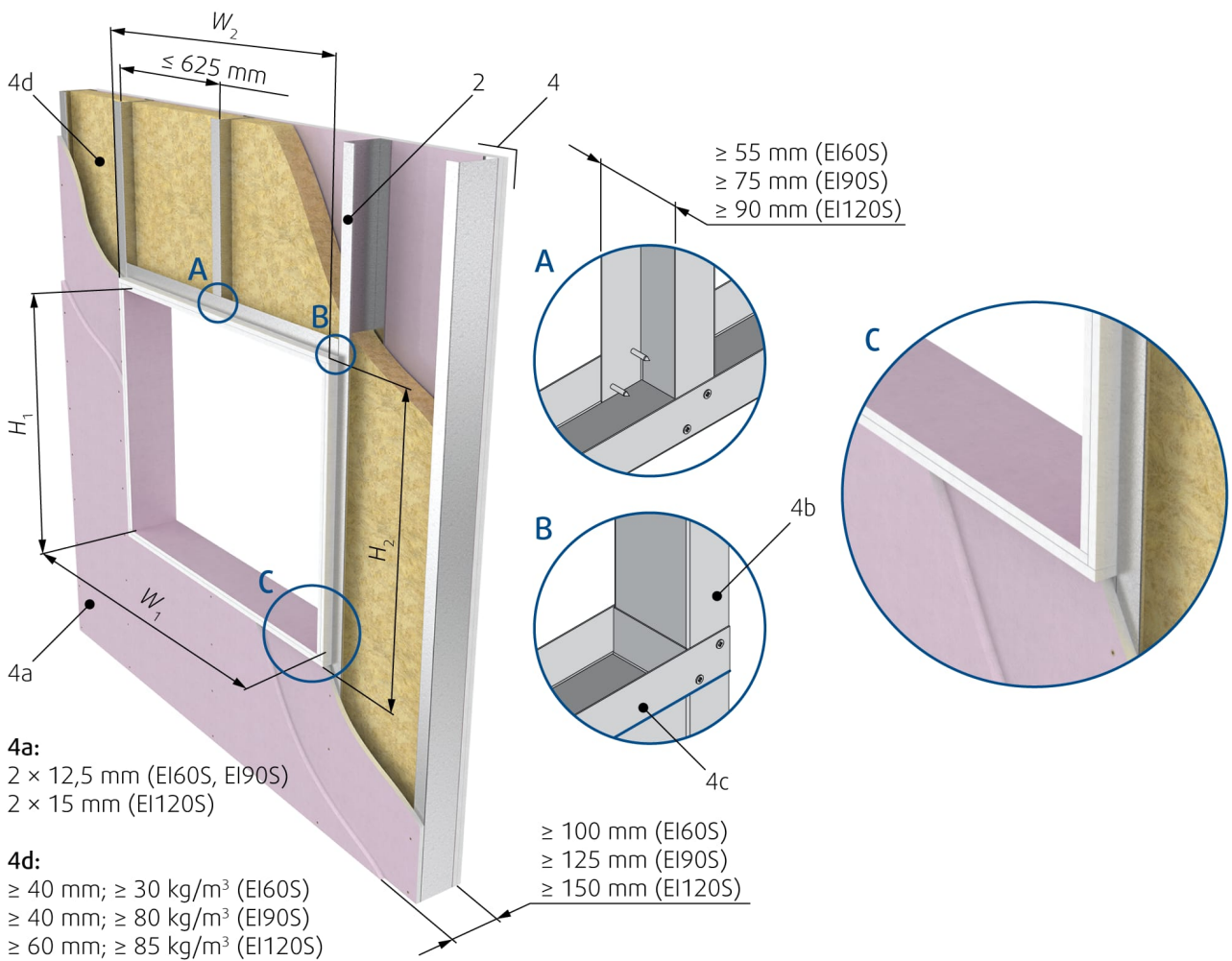
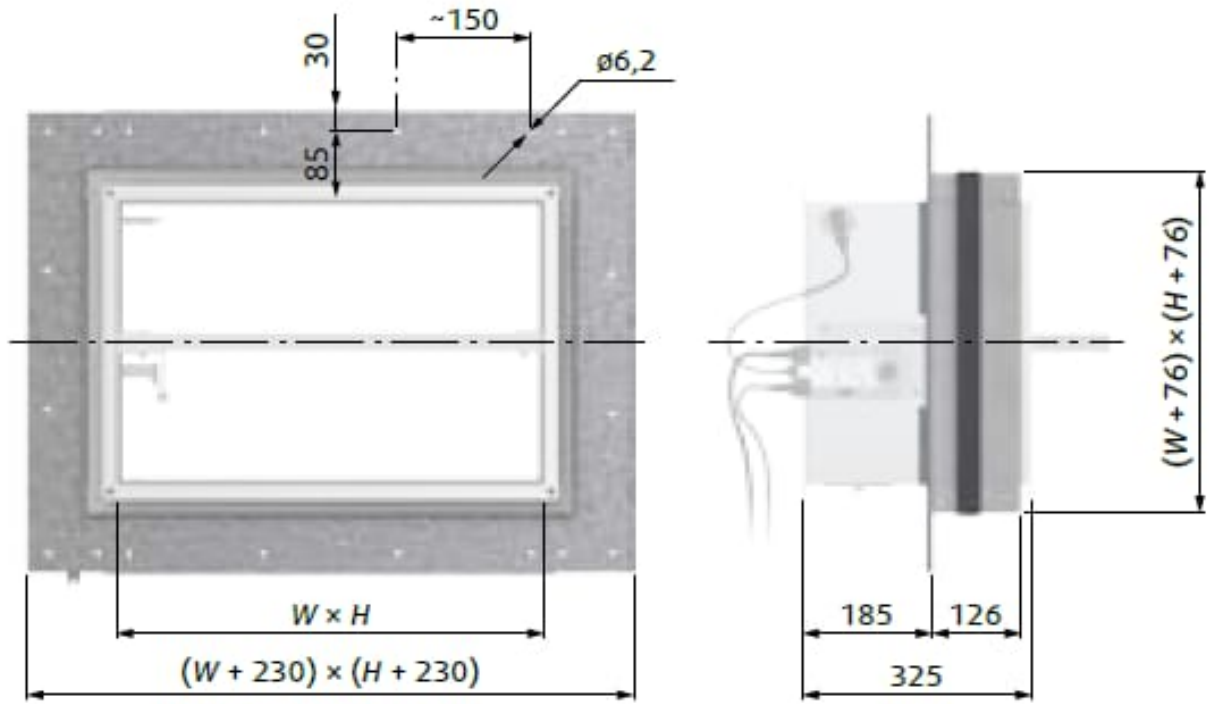

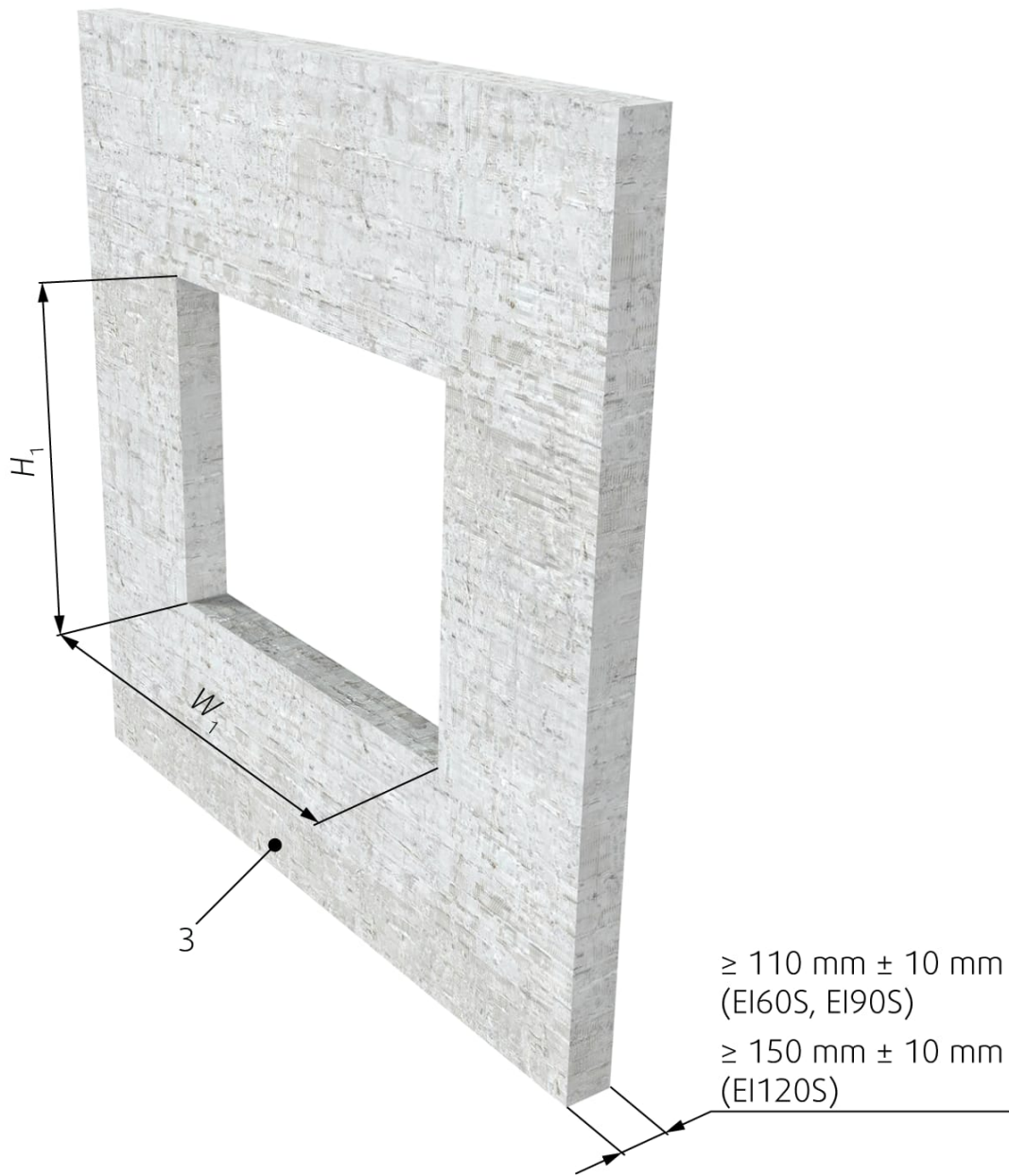

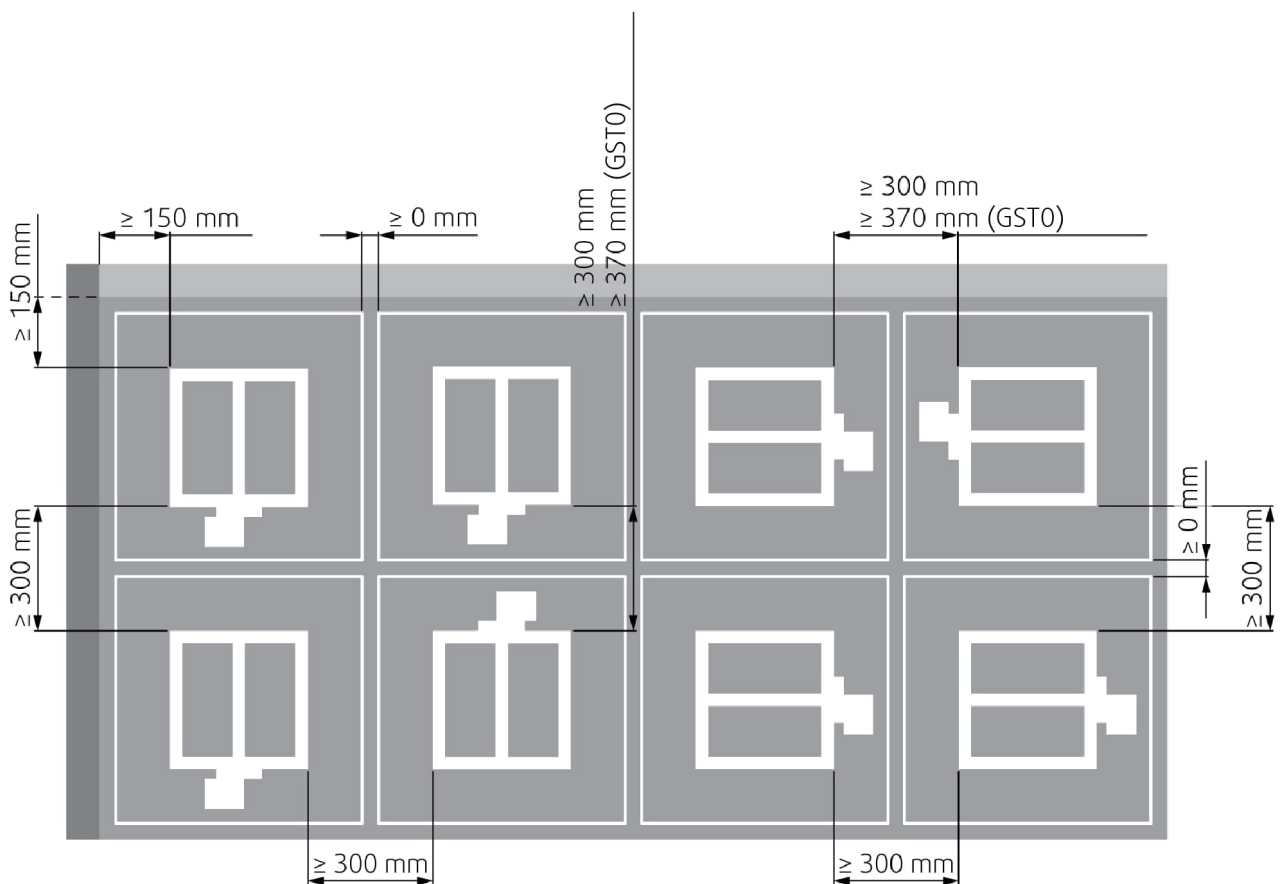
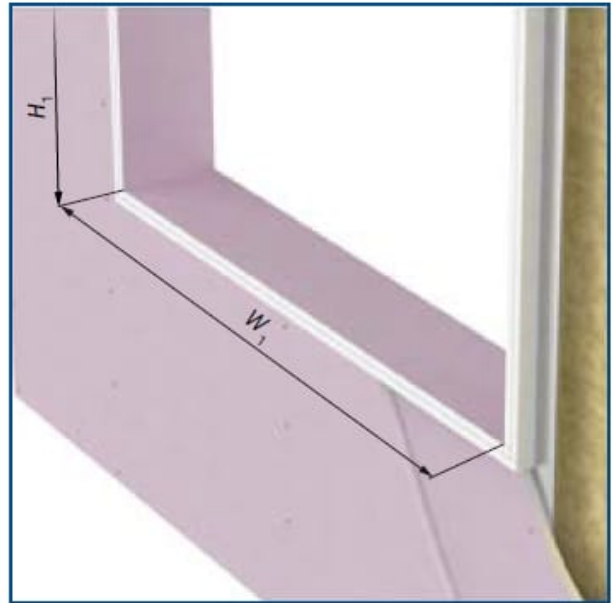
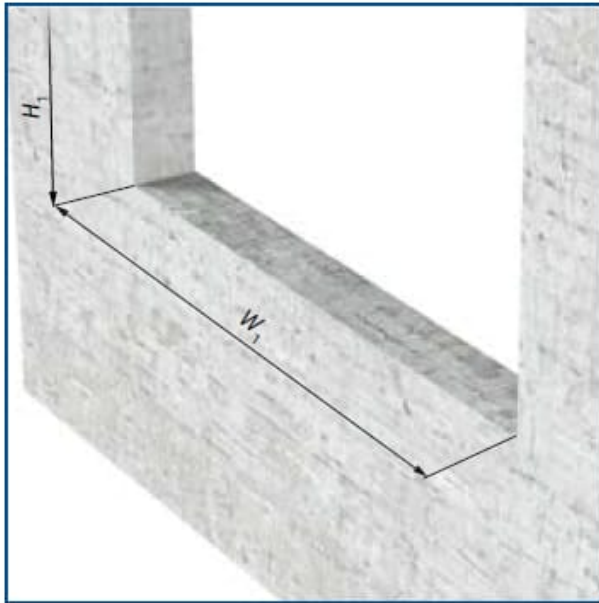

Legend

F1 Screw $\geq 5,5$ DIN7981 or suitable wall plug and screw size 6.

1 Fire damper with KIT (factory fitted)

2 Kit base plate - fixed directly onto the wall

3 Concrete/masonry/cellular concrete wall or ceiling

4 Flexible (plasterboard) wall

4a 2 layers of plasterboard fireproof plate type F, EN 520

4b Vertical CW - profiles

4c Horizontal CW - profiles

4d Mineral wool; thickness/cubic density see picture.

Notes

a) - Flexible (plasterboard) wall

b) - Concrete/masonry/cellular concrete (rigid) wall

v_e - Vertical wall

Electrical Connections

T/PC/A		W (mm)																			
		100	150	200	250	300	315	350	355	400	450	500	550	560	600	630	650	700	710	750	800
H (mm)	100																				
	150																				
	175																				
	180																				
	200																				
	250																				
	300																				
	315																				
	350																				
	355																				
	400																				
	450																				
	500																				
	550																				
	560																				
600																					

B230T-KS/6,5 VA/BFL230-T
 B24T-KS/4 VA/BFL24-T
 B24T-W-KS/4 VA/BFL24-T-ST
 B24T-SR-KS/6,5 VA/BFL24-T-SR

T/PC/A		W (mm)																			
		100	150	200	250	300	315	350	355	400	450	500	550	560	600	630	650	700	710	750	800
H (mm)	100																				
	150																				
	175																				
	180																				
	200																				
	250																				
	300																				
	315																				
	350																				
	355																				
	400																				
	450																				
	500																				
	550																				
	560																				
	600																				

G230T-KS/9,5 VA/340TA-230-05...
 G24T-KS/9 VA/340TA-024-05...
 G24T-W-KS/9 VA/340TA-024-05...ST01
 GST0-KS/11 VA/340TA-024-05...ST01 + fs-UFC24-2
 G24T-SR-KS/7,5 VA/340CTA-024-05...

NOTE:

T/PC/A - Activation Type / Power Consumption / Actuator

Type of activation H0-KS

This type of activation mechanism does not have any electrical equipment.

Type of activation H2-KS

IMPORTANT: Danger of electric shock!

Switch off the power supply before working on any electrical equipment.

Allow only qualified electricians to work on the electrical system.

Microswitch:Power Supply: AC 125/250 V or DC 12/24 V

Electric Parameters: 3A

NOTES:

- Supply via safety isolation transformer!

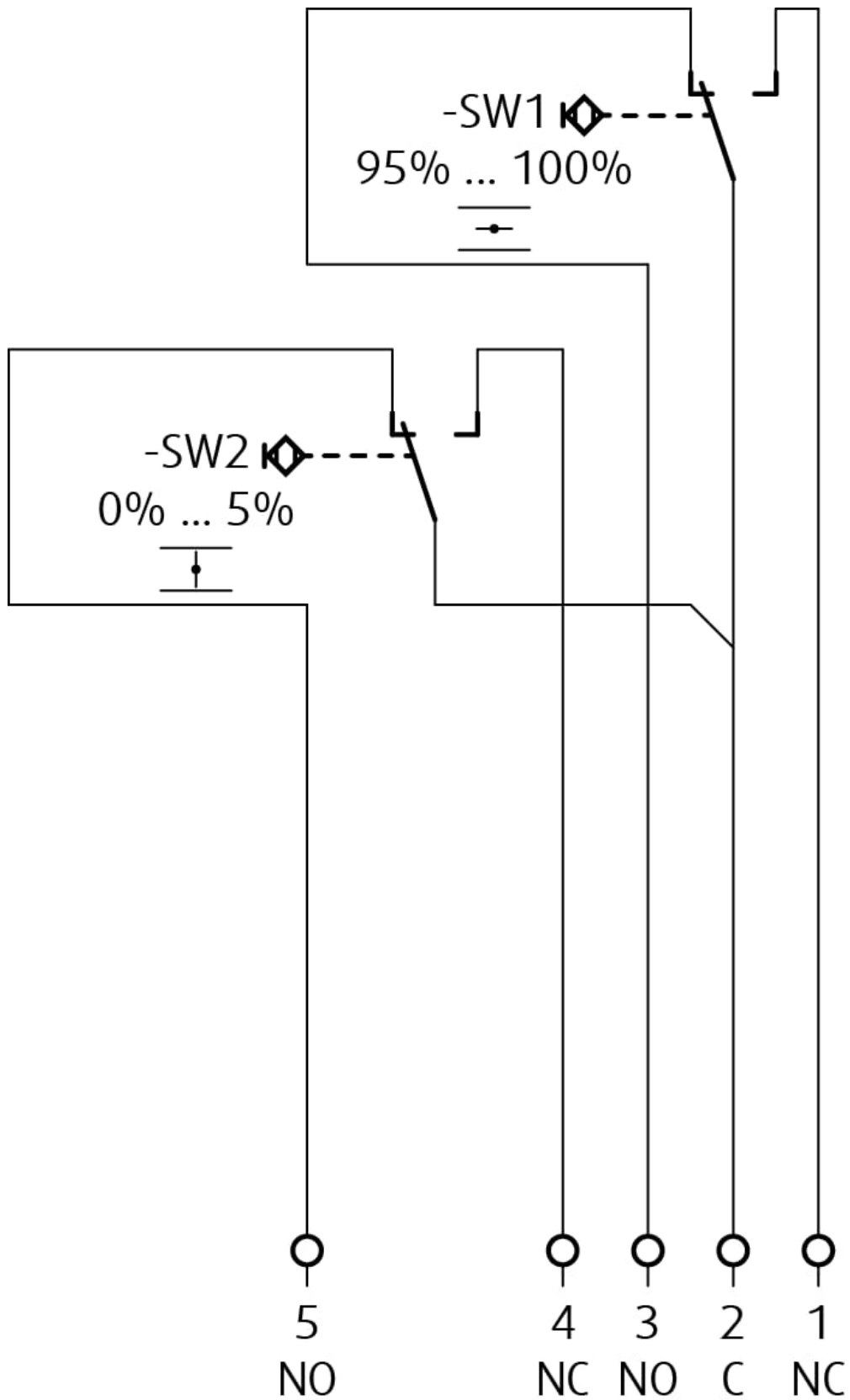

24 V AC/DC or 230 V AC

Legend

- 1 Grey cable colour
- 2 Orange cable colour

- 3** Pink cable colour
- 4** White cable colour
- 5** Red cable colour
- 6** Brown cable colour (Do not use for type of activation H2)
- X:7** Blue cable colour (Do not use for type of activation H2)

Type of activation H5-2-KS

IMPORTANT: Danger of electric shock!

Switch off the power supply before working on any electrical equipment.

Allow only qualified electricians to work on the electrical system.

Microswitch:

Power Supply: AC 125/250 V or DC 12/24 V

Electric Parameters: 3A

Impulse Electromagnet:

Power Supply: AC (50/60 Hz)/DC 24 V

Electric Parameters: 50 VA, load factor 10% (maximum 30 seconds in operation)

NOTES:

- 50 VA = Nominal activation power, maximum permissible magnet load = 300 VA
- Supply via safety isolation transformer.
- Power consumption must be monitored!

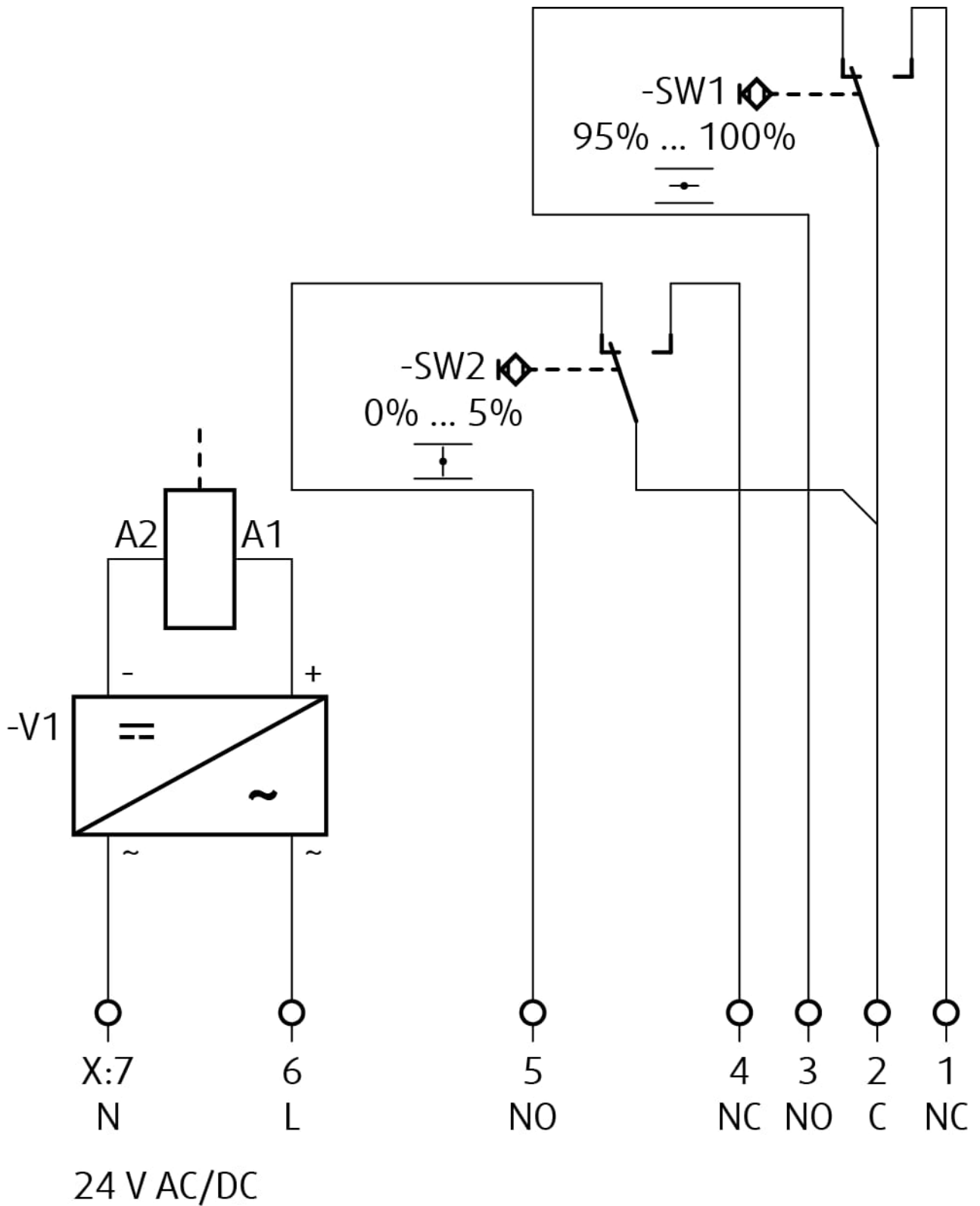

Legend

- 1 Grey cable colour
- 2 Orange cable colour
- 3 Pink cable colour
- 4 White cable colour
- 5 Red cable colour
- 6 Brown cable colour
- X:7 Blue cable colour

Type of activation H6-2-KS

IMPORTANT: Danger of electric shock!

Switch off the power supply before working on any electrical equipment.

Allow only qualified electricians to work on the electrical system.

Microswitch:

Power Supply: AC 125/250 V or DC 12/24 V

Electric Parameters: 3A

Impulse Electromagnet:

Power Supply: AC 230 V, 50/60 Hz

Electric Parameters: 50 VA, load factor 10% (maximum 30 seconds in operation)

NOTES:

- 50 VA = Nominal activation power, maximum permissible magnet load = 300 VA
- Caution! Main power supply voltage!
- A device that disconnects the pole conductors (minimum contact gap 3 mm) is required for isolation from the power supply.
- Power consumption must be monitored!

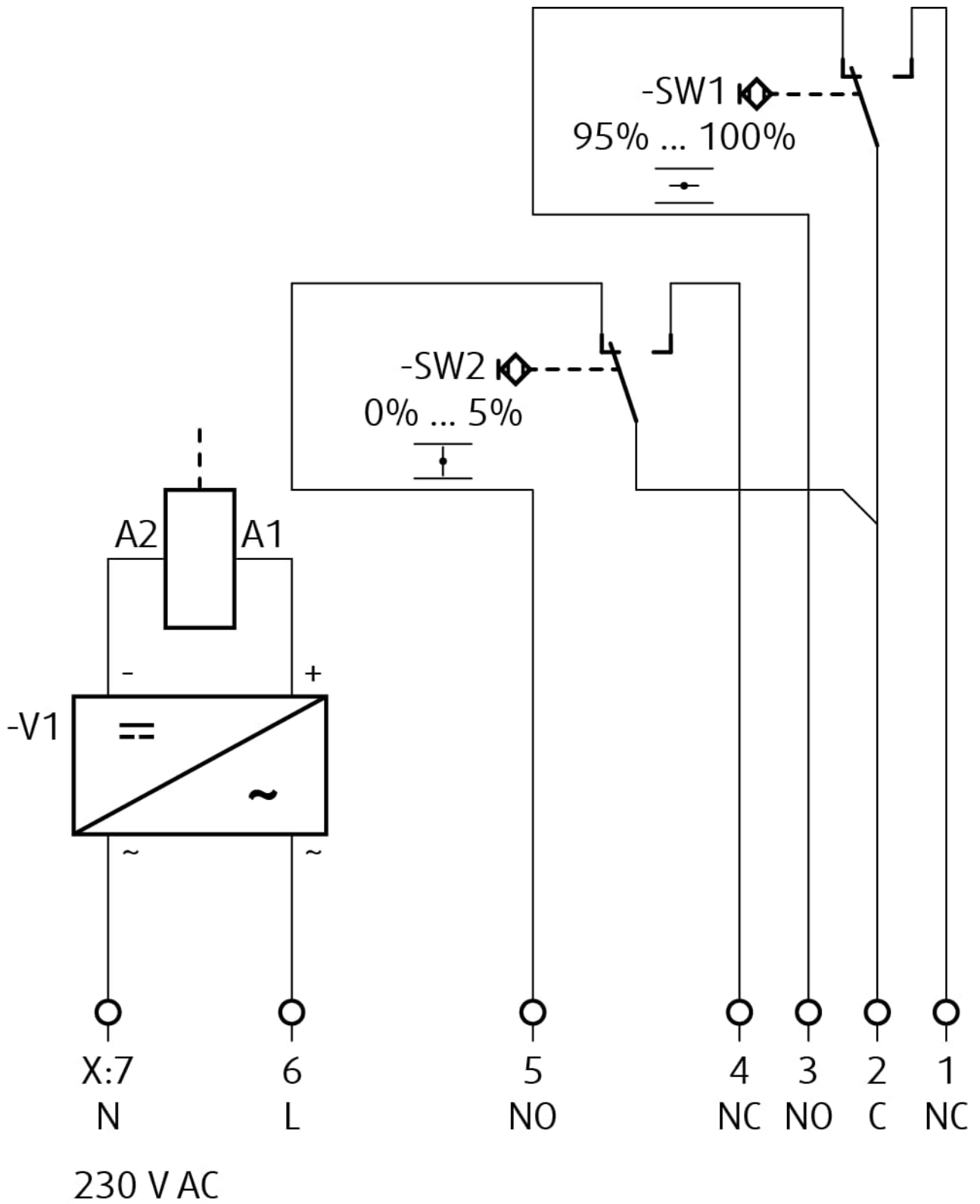

Legend

- 1 Grey cable colour
- 2 Orange cable colour
- 3 Pink cable colour
- 4 White cable colour
- 5 Red cable colour
- 6 Brown cable colour
- X:7 Blue cable colour

Type of activation B230T-KS

IMPORTANT: Danger of electric shock!

Switch off the power supply before working on any electrical equipment.

Allow only qualified electricians to work on the electrical system.

Actuator power supply: AC 230 V, 50/60 Hz

NOTES:

- Caution! Main power supply voltage!
- A device that disconnects the pole conductors (minimum contact gap 3 mm) is required for isolation from the power supply.
- Parallel connection of several actuators possible.
- Power consumption must be monitored!

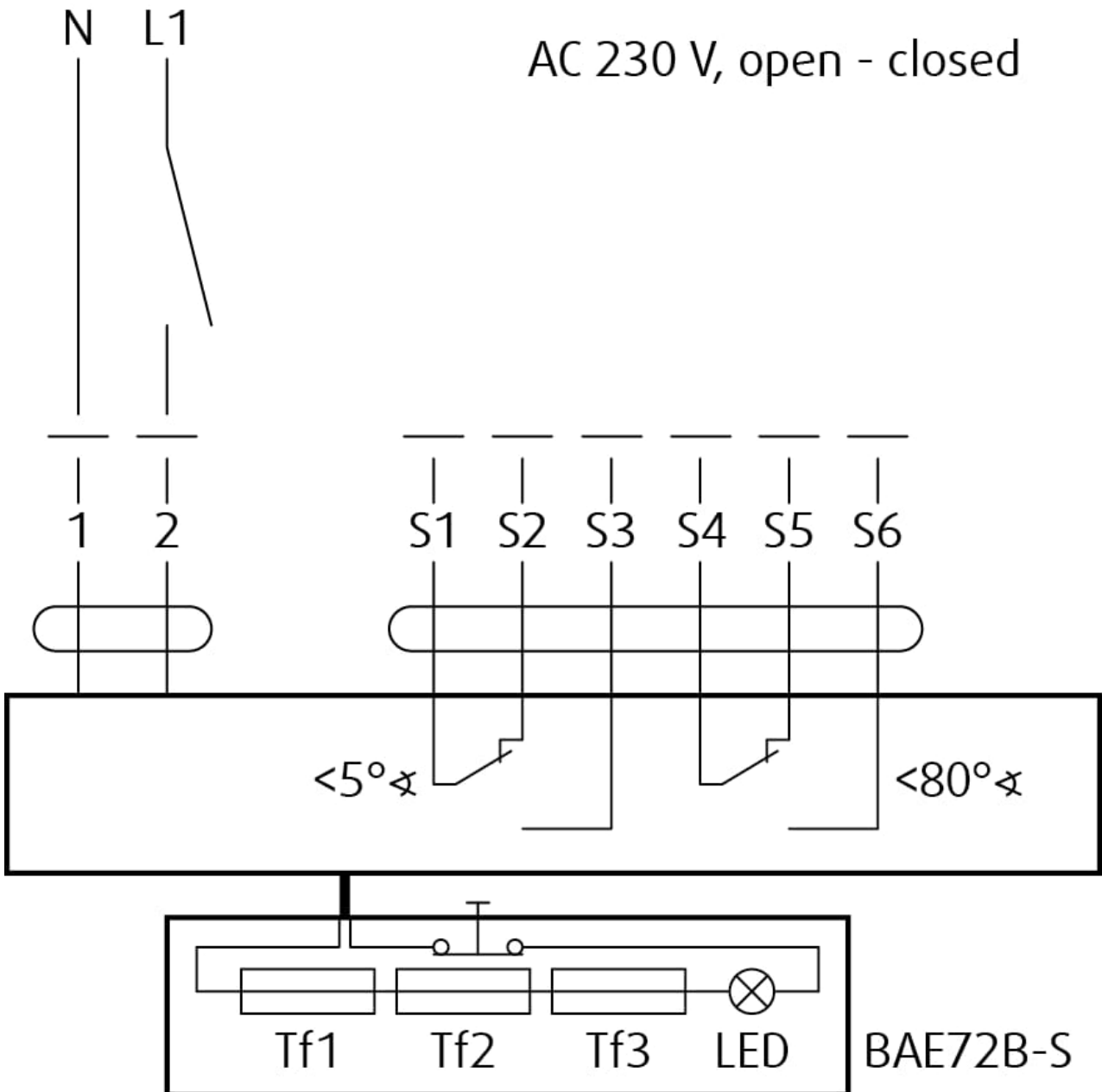
**Legend**

- 1** Blue cable colour
- 2** Brown cable colour
- S1** Violet cable colour

- S2** Red cable colour
- S3** White cable colour
- S4** Orange cable colour
- S5** Pink cable colour
- S6** Grey cable colour
- Tf** Thermal fuse

Type of activation G230T-KS

IMPORTANT: Danger of electric shock!

Switch off the power supply before working on any electrical equipment.

Allow only qualified electricians to work on the electrical system.

Actuator power supply: AC 230 V, 50/60 Hz

NOTES:

- Caution! Main power supply voltage!
- A device that disconnects the pole conductors (minimum contact gap 3 mm) is required for isolation from the power supply.
- Parallel connection of several actuators possible.
- Power consumption must be monitored!

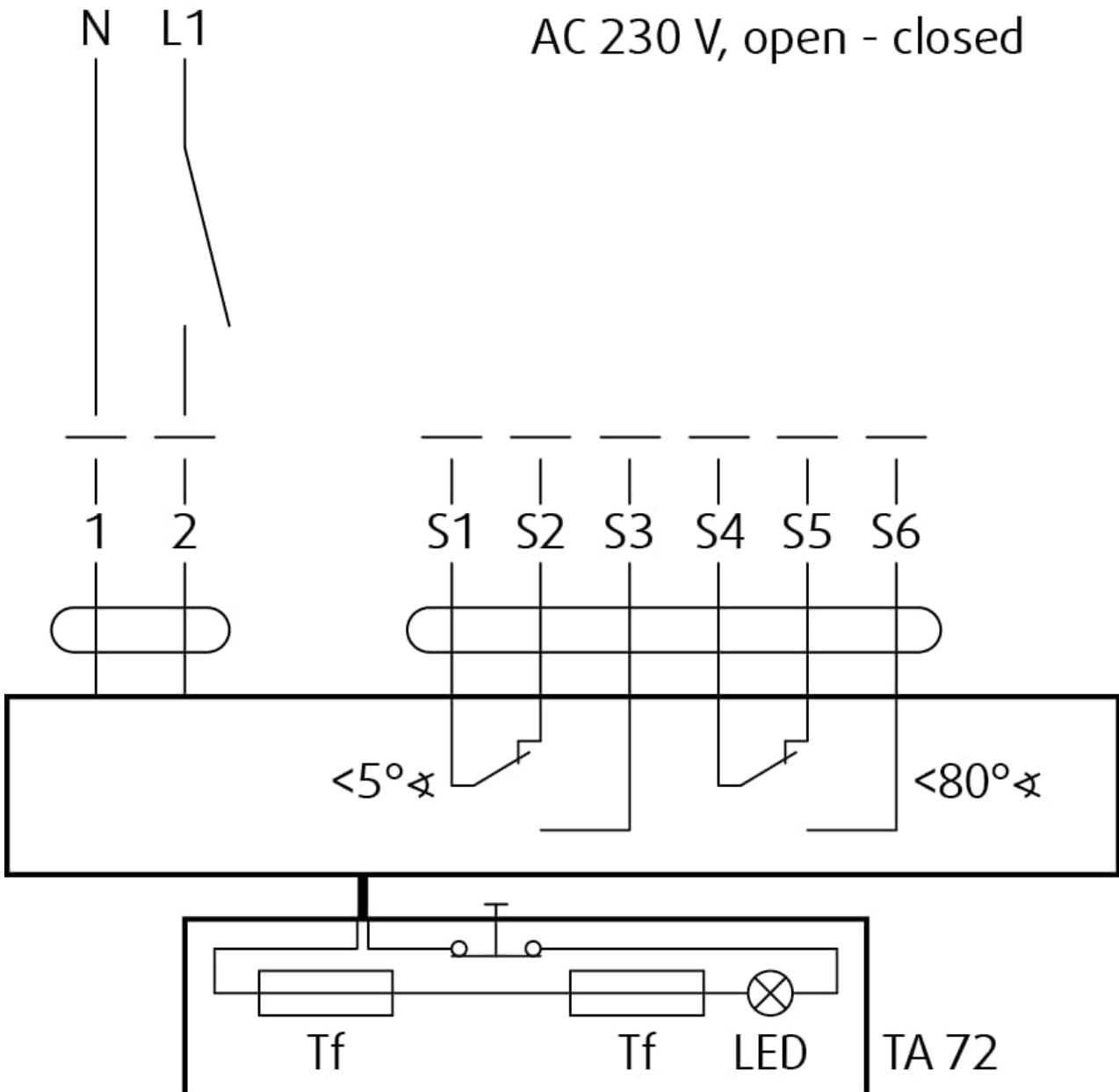

- S3** White cable colour
- S4** Orange cable colour
- S5** Pink cable colour
- S6** Grey cable colour
- Tf** Thermal fuse

Type of activation B24T-KS

IMPORTANT: Danger of electric shock!

Switch off the power supply before working on any electrical equipment.

Allow only qualified electricians to work on the electrical system.

Actuator power supply: AC (50/60 Hz)/DC 24 V

NOTES:

- Supply via safety isolation transformer.
- Parallel connection of several actuators possible.
- Power consumption must be monitored!

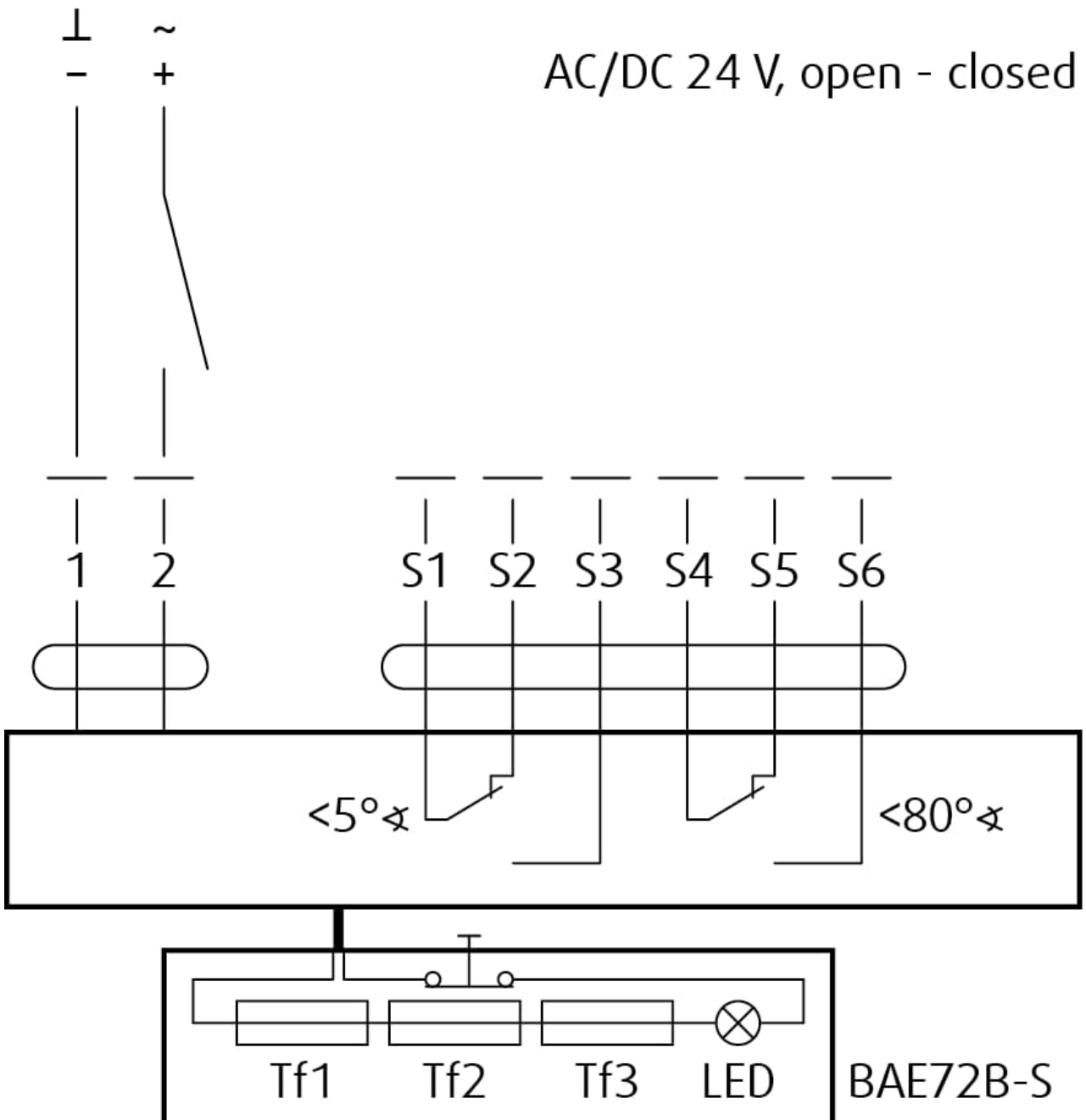

Legend

- 1 Blue cable colour (black for BF24-T)
- 2 Red cable colour (white for BF24-T)
- S1 Violet cable colour (white for BF24-T)
- S2 Red cable colour (white for BF24-T)

- S3** White cable colour (white for BF24-T)
- S4** Orange cable colour (white for BF24-T)
- S5** Pink cable colour (white for BF24-T)
- S6** Grey cable colour (white for BF24-T)
- Tf** Thermal fuse

Type of activation G24T-KS

IMPORTANT: Danger of electric shock!

Switch off the power supply before working on any electrical equipment.

Allow only qualified electricians to work on the electrical system.

Actuator power supply: AC (50/60 Hz)/DC 24 V

NOTES:

- Supply via safety isolation transformer.
- Parallel connection of several actuators possible.
- Power consumption must be monitored!

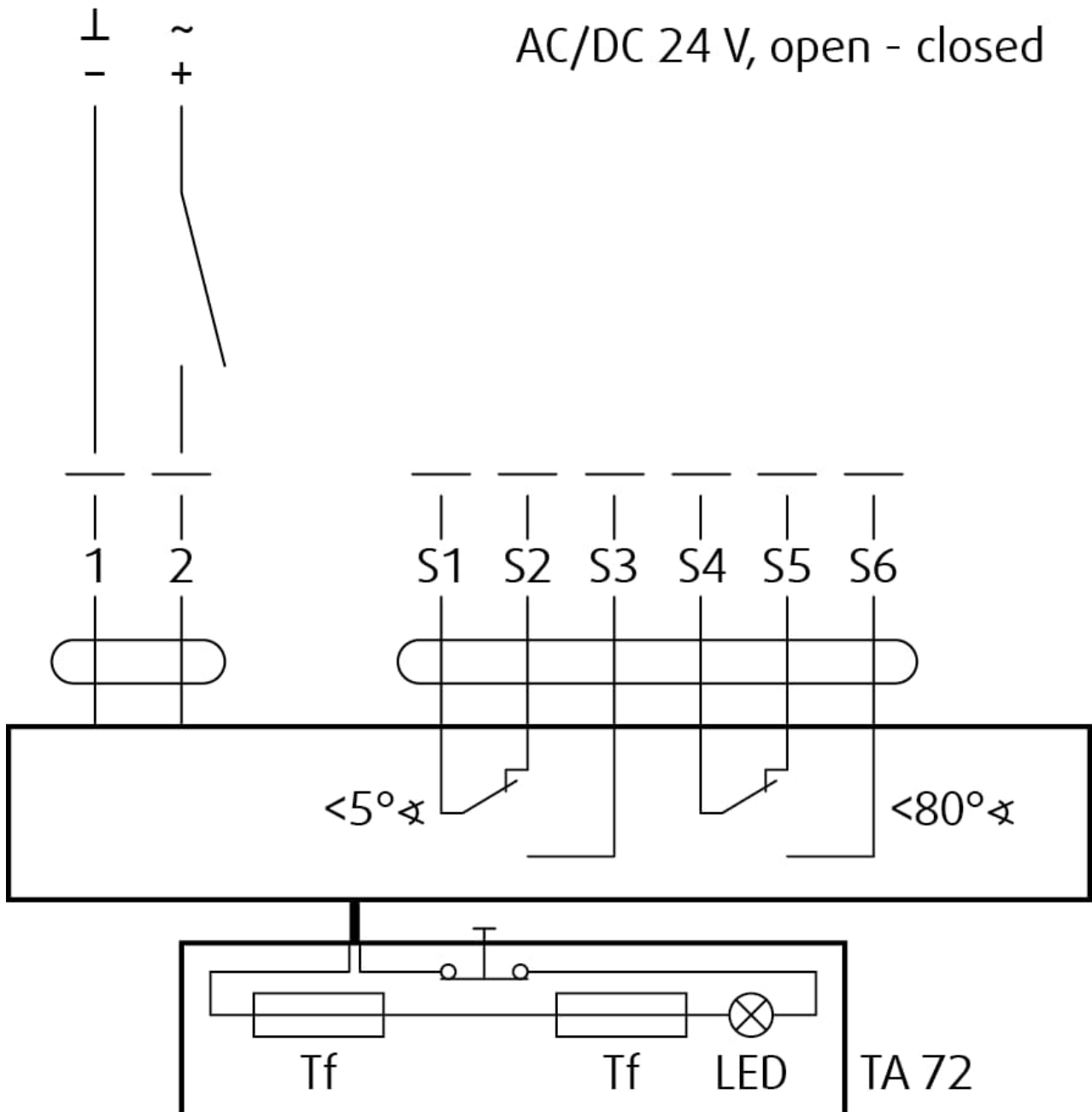

Legend

- 1** Black cable colour
- 2** Red cable colour
- S1** Violet cable colour
- S2** Red cable colour

- S3** White cable colour
- S4** Orange cable colour
- S5** Pink cable colour
- S6** Grey cable colour
- Tf** Thermal fuse

Type of activation GST0-KS

IMPORTANT: Danger of electric shock!

Switch off the power supply before working on any electrical equipment.

Allow only qualified electricians to work on the electrical system.

This type of activation is with a Gruner supply and communication unit fs-UFC24-2 (other communication units on demand).

Actuator power supply: AC (50/60 Hz)/DC 24 V

NOTES:

- Supply via safety isolation transformer.
- Power consumption must be monitored!

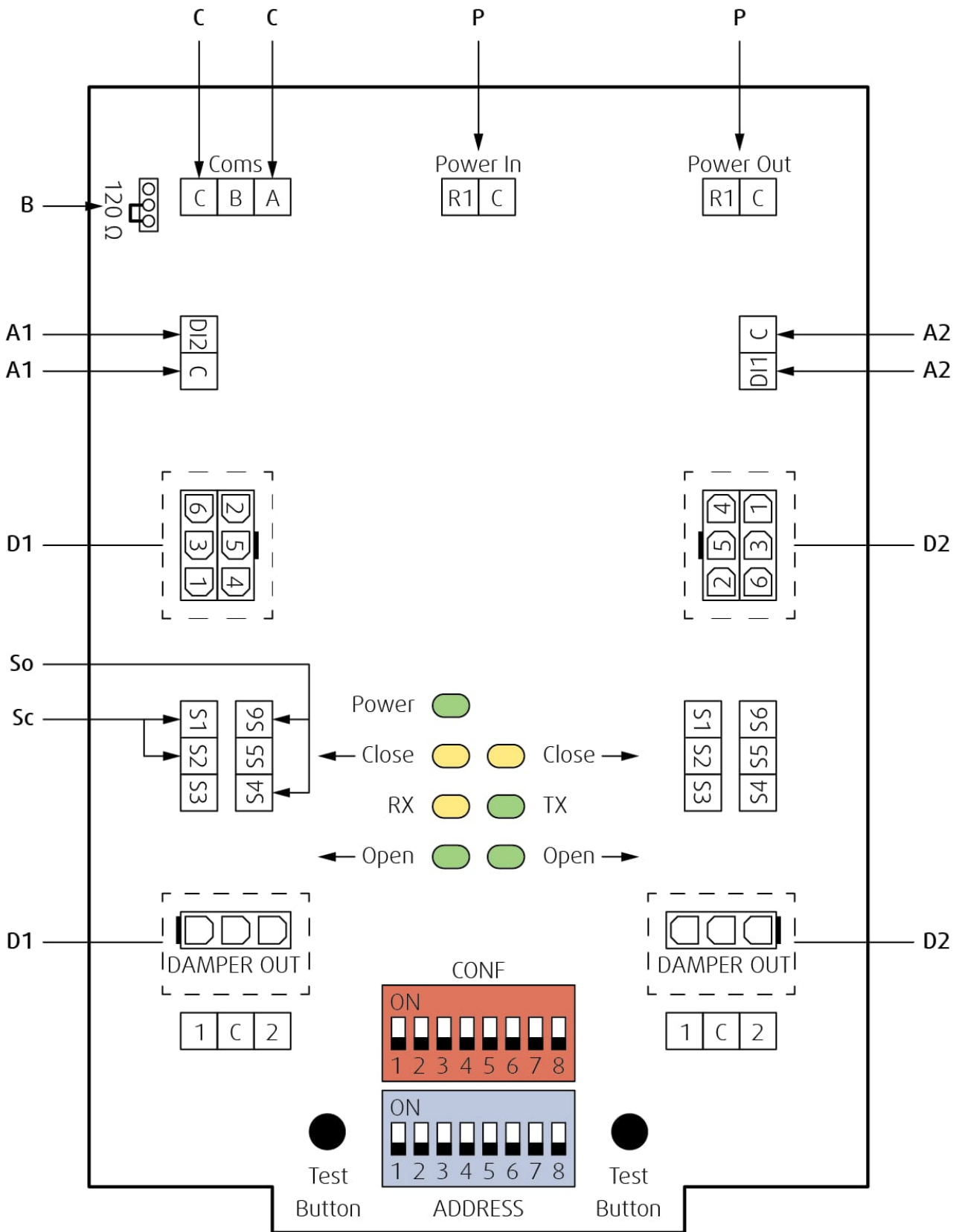

Legend

- A1, A2** Analog Application; Digital input for manual override can be selected via bus as „Normally Open“ (= standard open) or „Normally Closed“ (= standard closed) Default: „Normally Open“
- B** Position of line termination 120 ohm if FS-UFC24-2 is last Modbus or BACnet device in line
- C** RS-485 Coms; Modbus RTU or BACnet MS/TP dip switch selectable
- D1, D2** Damper 1, Damper 2; Fire or smoke extraction application

P Main power 24 V AC/DC; Daisy chain from and to other FS-UFC24-2

So Contact open

Sc Contact closed

Type of activation B24T-W-KS

IMPORTANT: Danger of electric shock!

Switch off the power supply before working on any electrical equipment.

Allow only qualified electricians to work on the electrical system.

This type of activation is with provided cable connectors for the supply and communication unit (communication unit not part of the mechanism).

Actuator power supply: AC (50/60 Hz)/DC 24 V

NOTES:

- Supply via safety isolation transformer.
- Parallel connection of several actuators possible.
- Power consumption must be monitored!

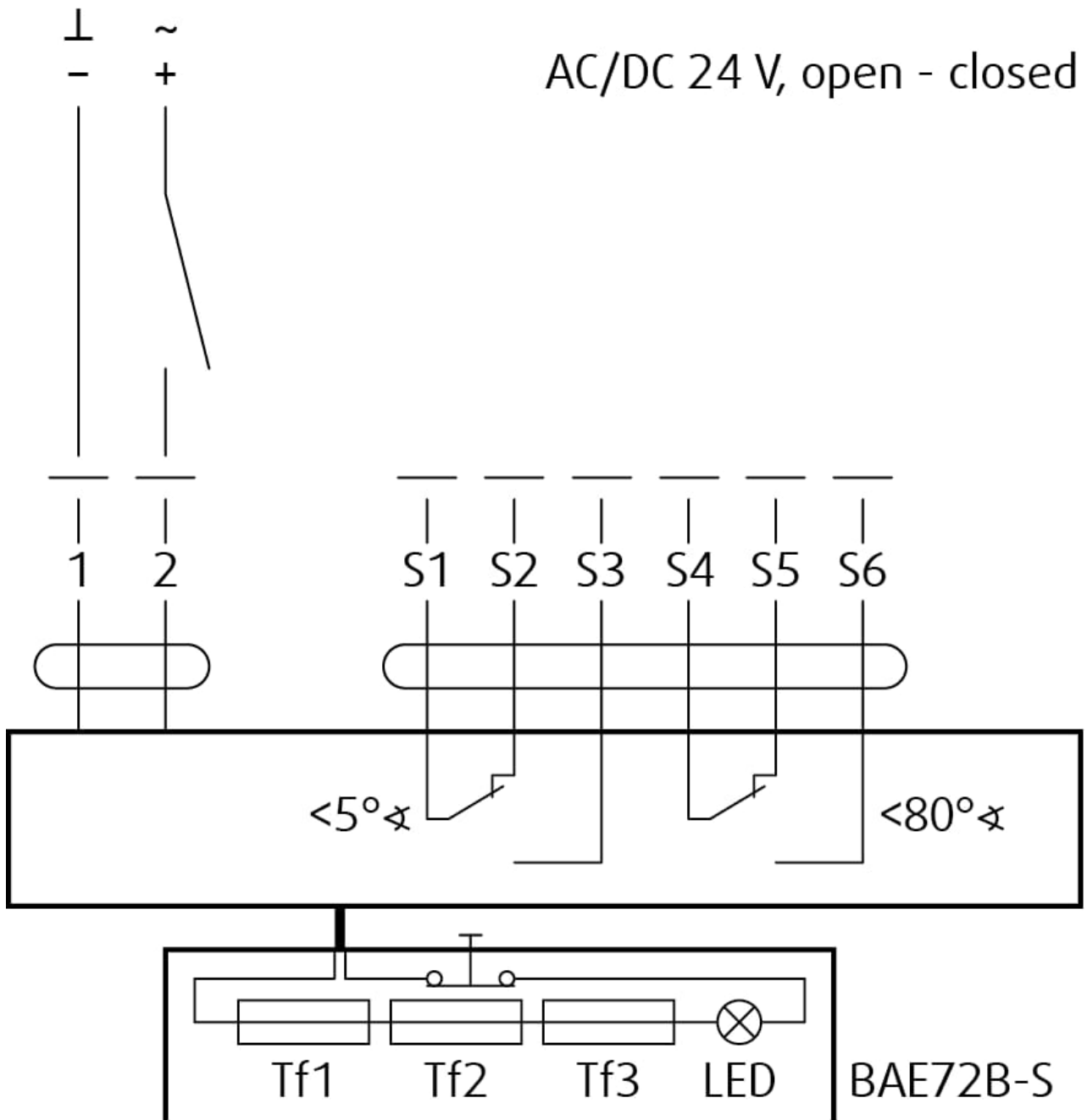

Legend

- 1 Blue cable colour (black for BF24-T) in connector 1
- 2 Brown cable colour (white for BF24-T) in connector 1

- S1** Violet cable colour (white for BF24-T) in connector 2
- S2** Red cable colour (white for BF24-T) in connector 2
- S3** White cable colour (white for BF24-T) in connector 2
- S4** Orange cable colour (white for BF24-T) in connector 2
- S5** Pink cable colour (white for BF24-T) in connector 2
- S6** Grey cable colour (white for BF24-T) in connector 2
- Tf** Thermal fuse

Type of activation G24T-W-KS

IMPORTANT: Danger of electric shock!

Switch off the power supply before working on any electrical equipment.

Allow only qualified electricians to work on the electrical system.

This type of activation is with provided cable connectors for the supply and communication unit (communication unit not part of the mechanism).

NOTES:

- Supply via safety isolation transformer.
- Parallel connection of several actuators possible.
- Power consumption must be monitored!

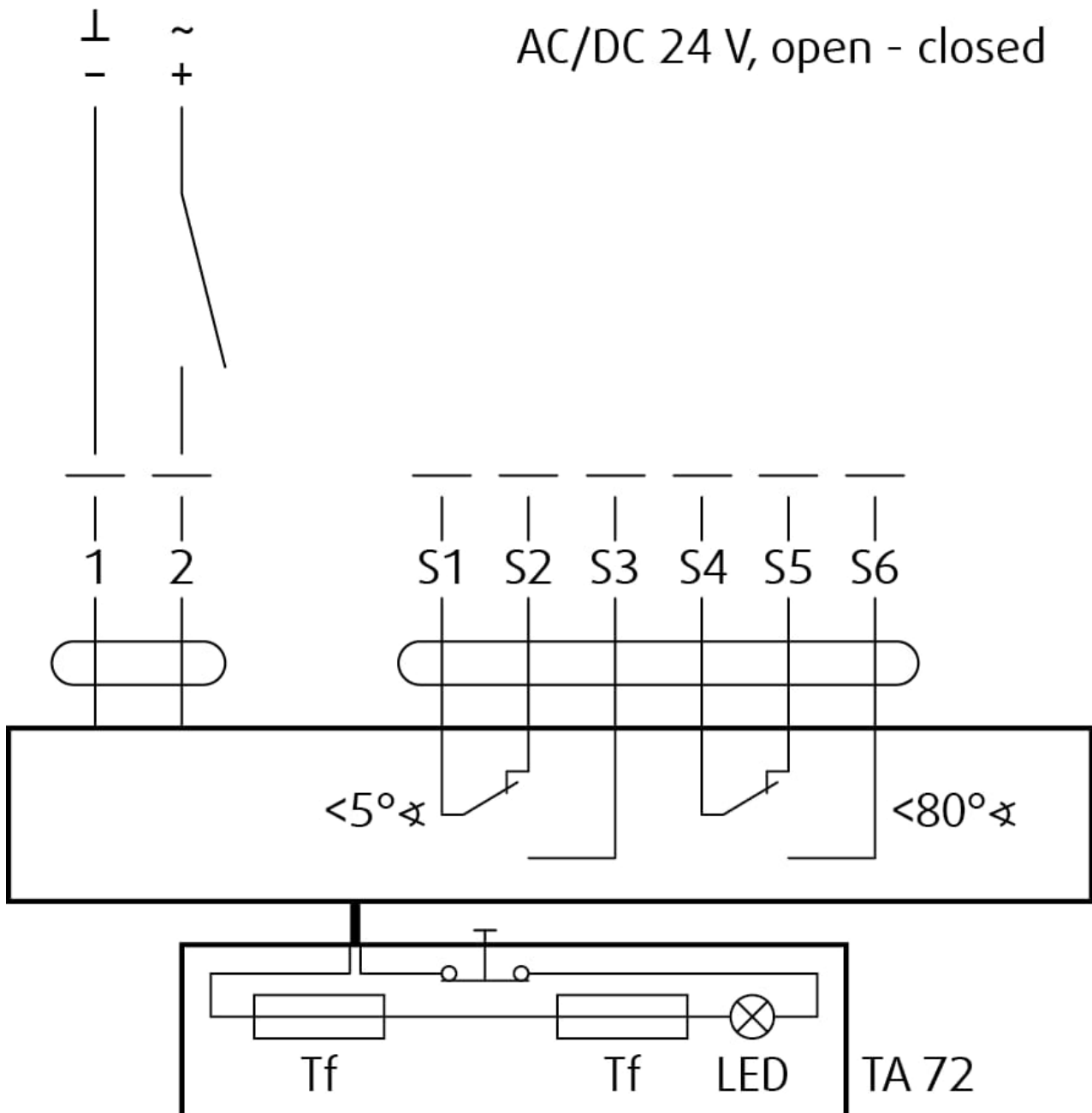

Legend

- 1 Black cable colour (black for BF24-T) in connector 1
- 2 Red cable colour (white for BF24-T) in connector 1
- S1 Violet cable colour (white for BF24-T) in connector 2

- S2** Red cable colour (white for BF24-T) in connector 2
- S3** White cable colour (white for BF24-T) in connector 2
- S4** Orange cable colour (white for BF24-T) in connector 2
- S5** Pink cable colour (white for BF24-T) in connector 2
- S6** Grey cable colour (white for BF24-T) in connector 2
- Tf** Thermal fuse

Type of activation B24T-SR-KS

IMPORTANT: Danger of electric shock!

Switch off the power supply before working on any electrical equipment.

Allow only qualified electricians to work on the electrical system.

Actuator power supply: AC (50/60 Hz)/DC 24 V

NOTES:

- Supply via safety isolation transformer.
- Power consumption must be monitored!

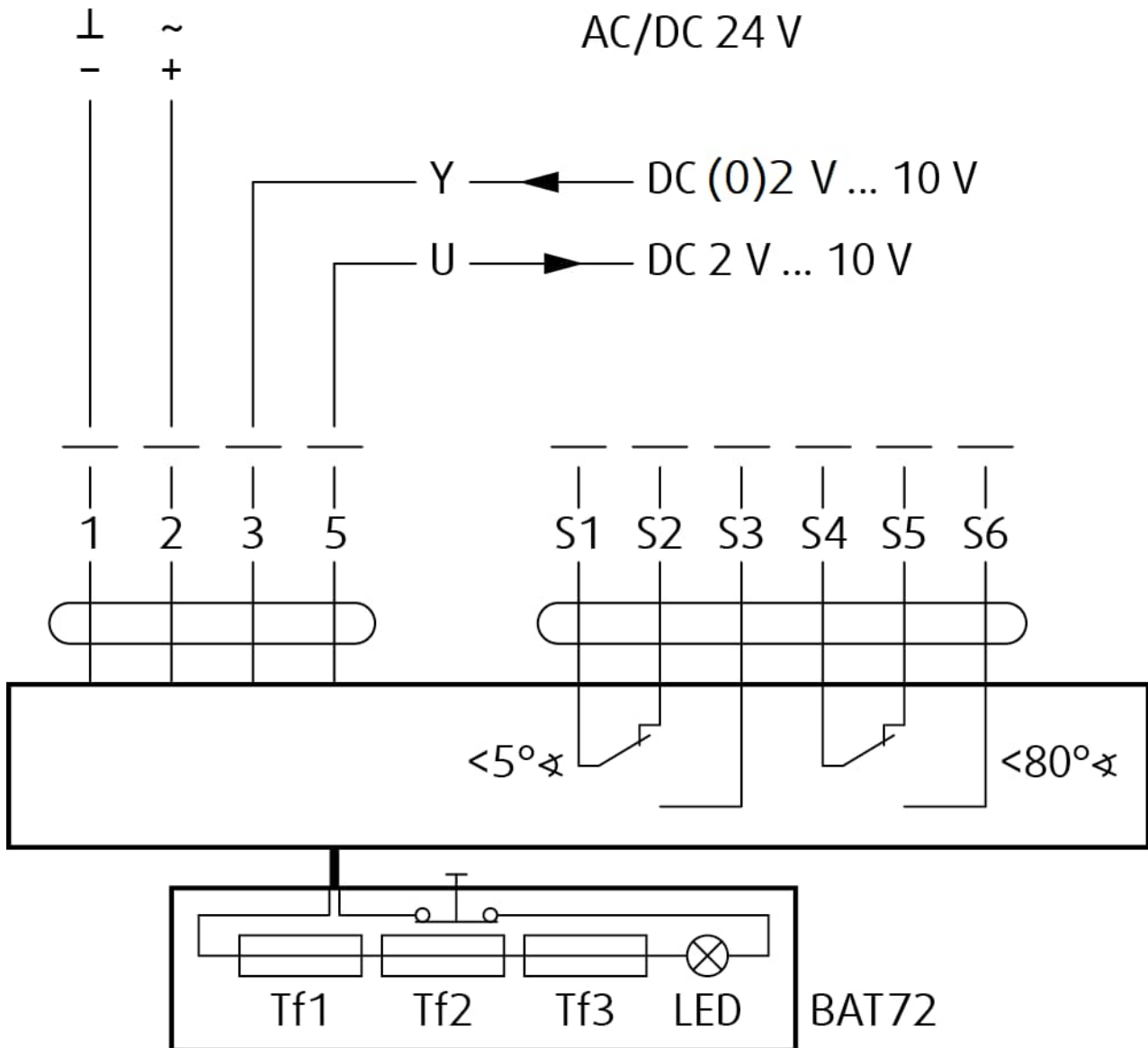
**Legend**

- 1 Blue cable colour
- 2 Brown cable colour
- 3 White cable colour
- 5 Orange cable colour
- S1 Violet cable colour
- S2 Red cable colour
- S3 White cable colour
- S4 Orange cable colour
- S5 Pink cable colour

S6 Grey cable colour

Tf Thermal fuse

Type of activation G24T-SR-KS

IMPORTANT: Danger of electric shock!

Switch off the power supply before working on any electrical equipment.

Allow only qualified electricians to work on the electrical system.

Actuator power supply: AC (50/60 Hz)/DC 24 V

NOTES:

- Supply via safety isolation transformer.
- Power consumption must be monitored!

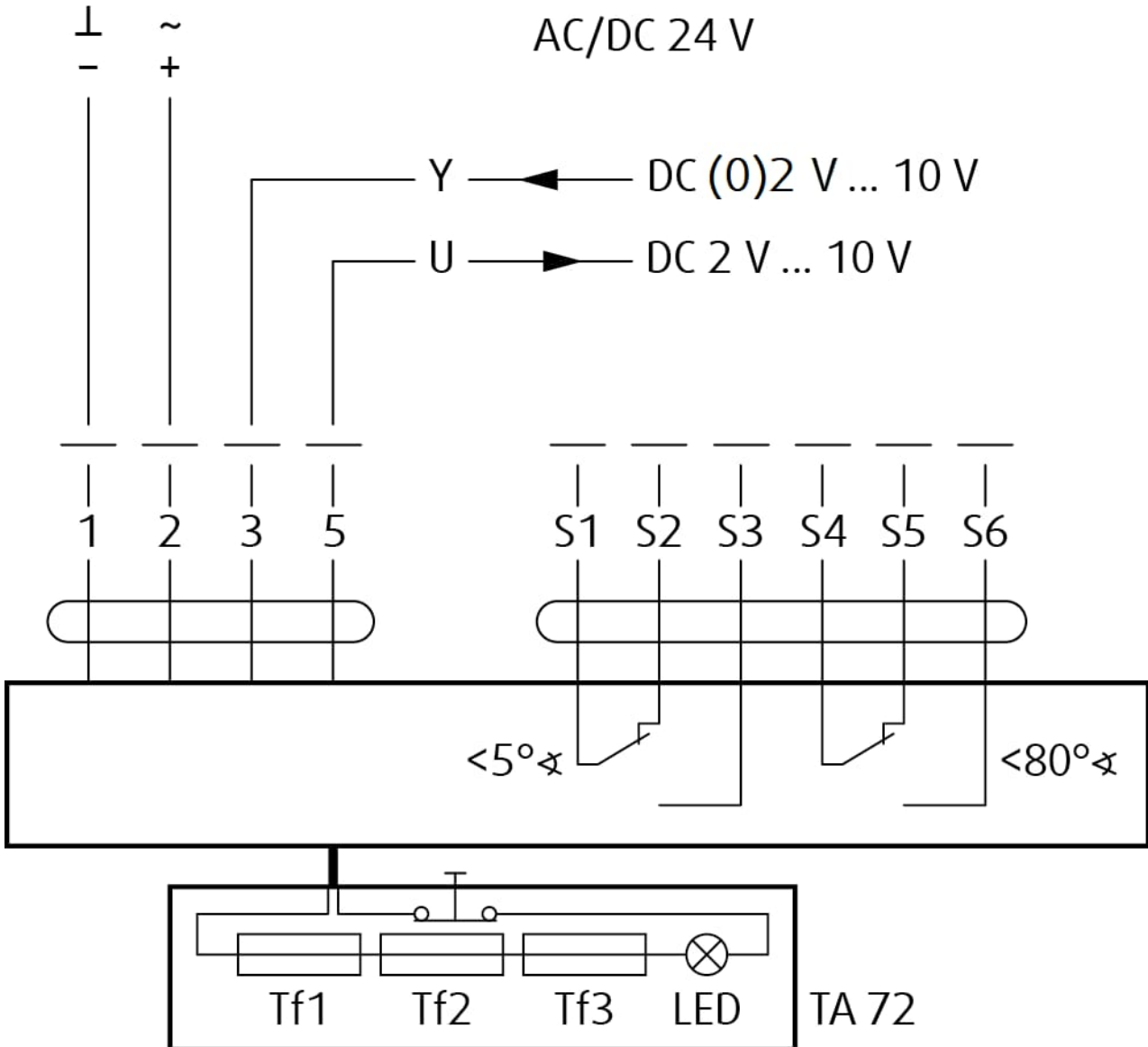
**Legend**

- 1 Blue cable colour
- 2 Brown cable colour
- 3 Black cable colour
- 4 Grey cable colour
- S1 Violet cable colour
- S2 Red cable colour
- S3 White cable colour
- S4 Orange cable colour
- S5 Pink cable colour

S6 Grey cable colour

Tf Thermal fuse

Operation Manual

Warning

To avoid injury, make sure to wear gloves and keep the blades movement area clear while manipulating with the damper. NEVER OPEN THE INSPECTION LID WHEN THERE IS AIR FLOWING IN THE DUCT CONNECTED TO THE FIRE DAMPER!

Fire Damper Functionality Check

Manually Operated Activation Mechanism

1. Open the damper - turn the red crank (P10) using a hexagon bent wrench No. 10 (P13). Turn the red crank so that the indicator arrow is pointing to the "OPEN" position (P11), the red crank needs to remain in the "OPEN" position, and the microswitch for the open position indication must be pushed (if installed).
2. Close the damper - release the mechanism by pressing the red release button (P9), the red crank will adjust its indicator arrow pointing to the "CLOSED" position (P12) and remain locked in this position, the microswitch for the closed position indication must be pushed (if installed).
3. Open the damper - turn the red crank (P10) using a hexagon bent wrench No. 10. (P13) Turn the red crank so that the indicator arrow is pointing to the "OPEN" position, the red crank needs to remain in the "OPEN" position, and the microswitch for the open position indication must be pushed (if installed).

Spring Return Actuator Operated Activation Mechanism

1. The fire damper must open automatically after the actuator circuit closes - the arrow on the actuator axis must show the position 90°.
2. Press the control switch (P9) on the Thermoelectric fuse and hold it until the fire damper is fully closed - the arrow on the actuator axis must show the position 0°.
3. Release the control switch on the Thermoelectric fuse. The fire damper must become fully open - the arrow on the actuator axis must show the position 90° - which is the operating position.

Operation Manual

After installation, it is necessary to adjust the damper into its operating position - open the fire damper.

Spring Return Actuator Operated Activation Mechanism

Connect the electric driving mechanism to the relevant electric power supply (see Electrical connection section). The electromotor is activated and adjusts the damper into its open position.

Manually Operated Activation Mechanism

Turn the red crank into the "OPEN" position. The damper blade must remain in open position.

Damper Inspection

The activation mechanism keeps the dampers on stand-by during their entire life cycle in accordance with this manual issued by the manufacturer. It is not permitted to alter the dampers in any way nor perform any changes to their structure without the manufacturer's consent. The operator performs regular checks of the dampers as per established regulations and standards at least once every 12 months. The check needs to be performed by an employee who has been specifically trained for this purpose.

The current fire damper condition determined during the inspection needs to be entered into the operating logbook along with the date of the inspection, the legible name, surname and signature of the employee who performed the inspection. The Operating Journal includes a copy of the employee's authorization. If any discrepancies are discovered, these need to be entered in the Operating Journal along with a proposal for their removal.

The Operating Journal can be found in product documents section. Immediately after the installation and activation of the damper, it needs to be checked under the identical conditions as apply to the above mentioned 12-month inspections. The visual check ensures that visible damages on the inspected damper parts are seen. On its external side, the damper housing and the activation mechanism are checked.

Due to the need to perform a visual check of the damper's internal parts, open the inspection lid. For small sizes there is the possibility of removing the mechanism to perform the inspection. The removable mechanism always needs to be returned back into the damper with the damper blade being closed.

The damper's internal casing, thermal fuse, sealings, foaming substance, the damper blade condition and accuracy of its closure during its leaning against the backstop in the closed position must all be checked. There must not be any strange objects or a layer of impurities from the air distribution systems inside the damper.

Recommended Inspection Steps According to the EN 15 650:

1. Damper identification
2. Date of inspection
3. Inspecting electric connection of the activation mechanism (where applicable)
4. Inspecting damper for cleanliness and possible need for cleaning (where needed)
5. Inspecting blade and sealing condition, possible correction and logging (where needed)
6. Inspecting proper fire damper closure
7. Inspecting damper functionality – opening and closing using the control system, physical examination of the damper's behavior, possible correction and logging (where needed)
8. Inspecting end switches' functionality in the open and closed position, possible correction and logging (where needed)
9. Inspect whether the damper is fulfilling its role as part of the regulation system (where needed)
10. Inspect whether the damper remains in its standard operating position.
11. The damper is usually part of a system. In that case the whole system needs to be checked as described in its operation and requirements published by the builder of the system.

