

Käsikirja

NOTUS-S

CAV -säädin



Sisällysluettelo

Kuvaus	3
Mitat & painot	10
Tilaukoodit	12
Lisätarvikkeet	13
Pikavalinta	20
Tekniset parametrit	21
Asennus	29
Kuljetus, varastointi ja käyttö	30
Muutokset	31



Description

NOTUS-S is a constant air volume flow controller with mechanical operation (no need for auxiliary energy or actuation). The product is intended to control the constant air flow independently of the duct air pressure in the range of 50 Pa to 1000 Pa. The product is installed into rectangular ducts. The constant air flow value can be adjusted by a rotating dial within a range dependent on the size of product manually (type M0) or by an electric actuator (type M1). The product is ideal for all applications, where a reliable, precise and cost effective air flow control is required.

Highlights

- Easy tool-less setpoint adjustment – manually or by actuator
- CAV control ratio 3:1
- Static pressure independent control in range of 50 Pa to 1000 Pa
- Control accuracy with max. 10% flow volume deviation
- Rectangular sizes up to 600 × 600 mm
- Installable in horizontal and vertical ducts
- Casing tightness class “C” as per EN 1751

Product Types

- NOTUS-S...M0: CAV Controller with Manual Adjustment
- NOTUS-SI...M0: Insulated CAV Controller with Manual Adjustment
- NOTUS-S...M1(M2): CAV Controller with Actuator Adjustment (M1 continuous, M1/M2 2-point)
- NOTUS-SI...M1(M2): Insulated CAV Controller with Actuator Adjustment (M1 continuous, M1/M2 2-point)

NOTE: The type M0 can be additionally equipped by the actuator kit and upgraded so to the type M1 or M2. Types M1 and M2 are available only in sizes with height smaller than 500 mm (single control mechanism).

List of Accessories

Detailed information about accessories for NOTUS-S is available on page 12.

The accessories are available only for NOTUS in sizes with height smaller than 500 mm (single control mechanism)

- M1A-NOTUS: Actuator Kit
Supply AC 24V, continuous control DC 0 V ... 10 V, or 2-point (small CAV dimensions)
- M1B-NOTUS: Actuator Kit
Supply AC 24V, continuous control DC 0 V ... 10 V, or 2-point (large CAV dimensions)
- M2A-NOTUS: Actuator Kit
Supply AC 100 ... 240V, 2-point control (small CAV dimensions)
- M2B-NOTUS: Actuator Kit
Supply AC 100 ... 240V, 2-point control (large CAV dimensions)
- LDR-A: Sound Attenuator

Design

NOTUS-S is manufactured from galvanized steel sheet with 20 mm flange duct connections at the ends. The control damper blade material is aluminium. The product consists of a casing, a duct connection flange, a CAV control mechanism, an adjustment position indicator, a flow adjustment dial, an adjustment table and an actuator (only for NOTUS-S... M1/M2). The casing of NOTUS-S in all types has leakage class C according to EN 1751 (the damper blade is not intended for the shut-off function so the blade leakage is not classified). A version with acoustic insulation (NOTUS-SI...) has a 1,9 cm polymer foam layer around the casing, covered by a galvanized sheet mantle. The control mechanism on the outer surface of the body consists of ABS plastic levers and transmissions, steel springs, silicone-oil-filled rotary shock absorber, all covered by a ABS box. The types M1 and M2 are delivered with a pre-installed flow adjustment actuator. On type M0 (with manual adjustment) the actuator kit can be installed additionally. Types M1 and M2 are available only in sizes with height smaller than 500 mm (single control mechanism).

Tuotteen osat

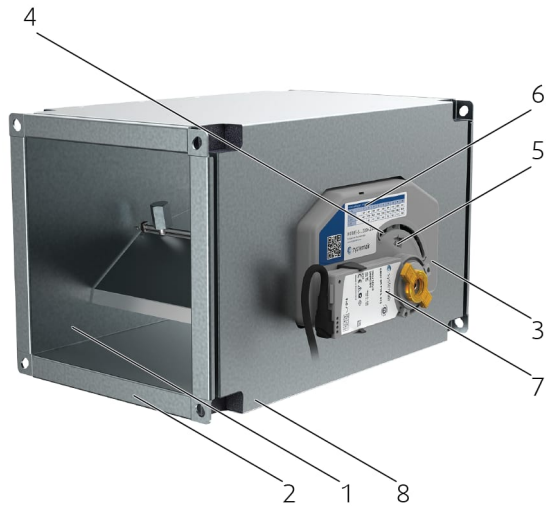

Legend

- 1 Casing
- 2 Duct connection flange 20 mm
- 3 CAV control mechanism
- 4 Adjustment position indicator
- 5 Flow adjustment dial (with arresting bolt only on NOTUS-S...M0)
- 6 Adjustment table
- 7 Actuator (only for NOTUS-S... M1/M2)
- 8 Insulation + Covering (only on NOTUS-SI)

Setup Possibilities

NOTUS-S...M0

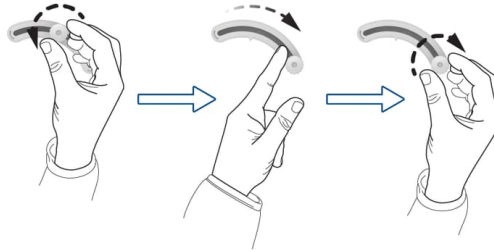
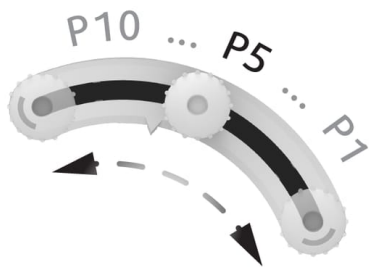

1a

1b

Air flow settings $\Delta P = 50 \text{ Pa} \dots 1000 \text{ Pa}$					
Pos. No.	200	244	289	333	378
q_v (m ³ /h)	200	244	289	333	378
q_v (l/s)	55,5	67,9	80,2	92,6	104,5
U_c (V)	0	1,2	2,3	3,5	5

320



$p \approx 3,5$



$$P = \frac{4 - 3}{333 - 289} \cdot (320 - 289) + 3$$

$p = 3,704$



2.

✓



$q_v = 320 \text{ m}^3/\text{h}$

NOTUS-S...M1



CM24-SRV

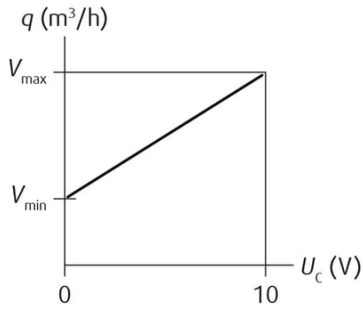

LM24-SRV

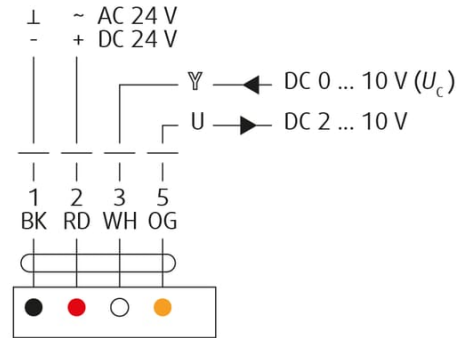

1a

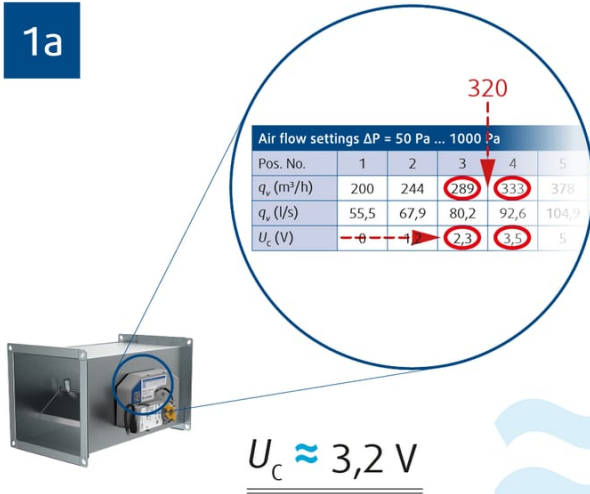

1b

$$U_c = \frac{3,5 - 2,3}{333 - 289} \cdot (320 - 289) + 2,3$$

$U_c \approx 3,2 \text{ V}$



$U_c = 3,15 \text{ V}$



2.

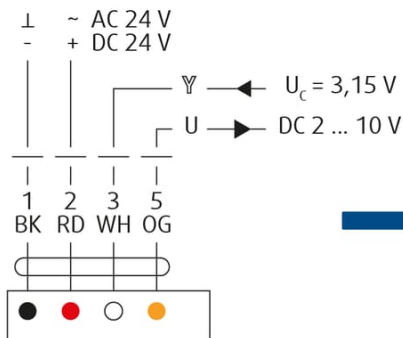

✓



$q_v = 320 \text{ m}^3/\text{h}$

NOTUS-S...M1

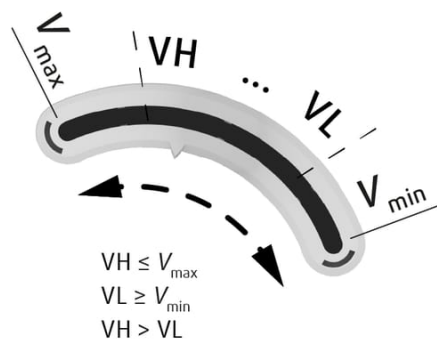
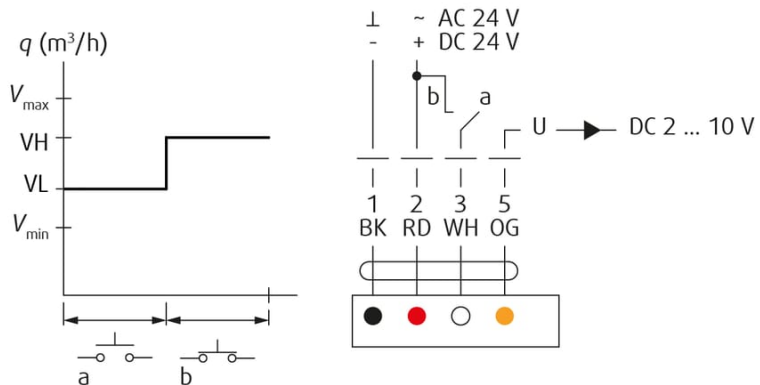

LM24-SRV

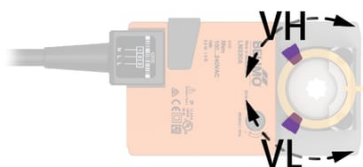

1.

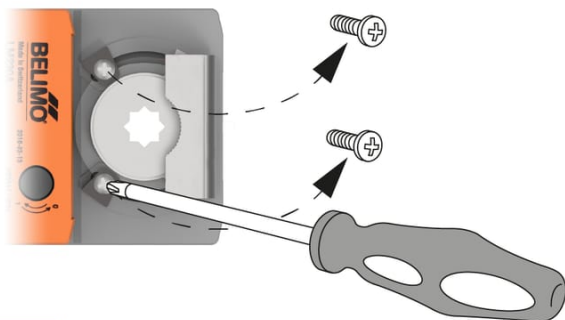

2.



3.

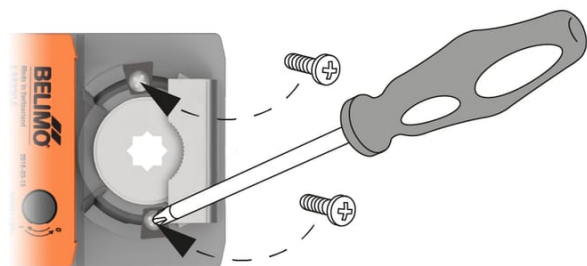

CM24-SRV

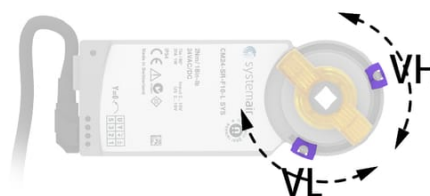

1.

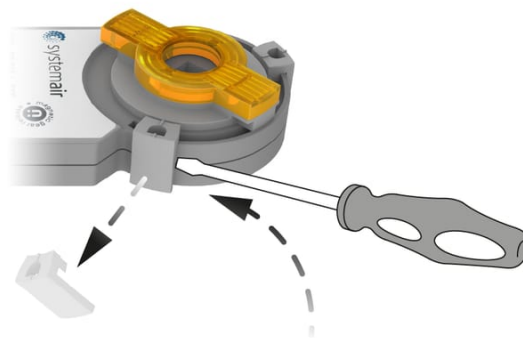

2.

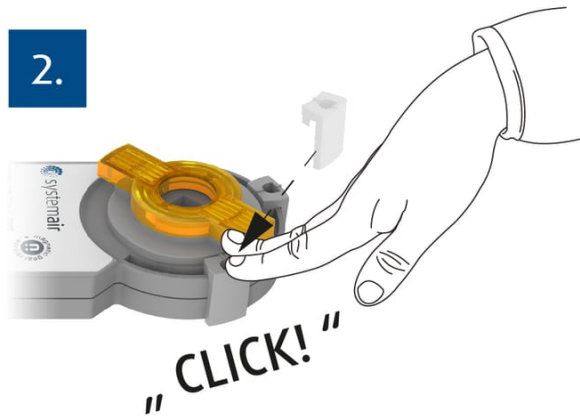

NOTUS-S...M2

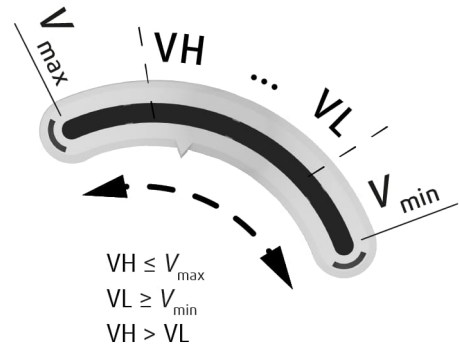
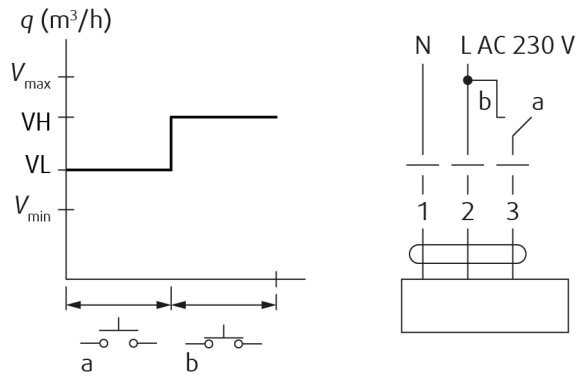

LM230

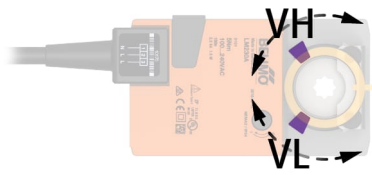

CM230

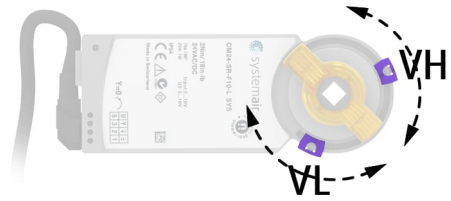

1.

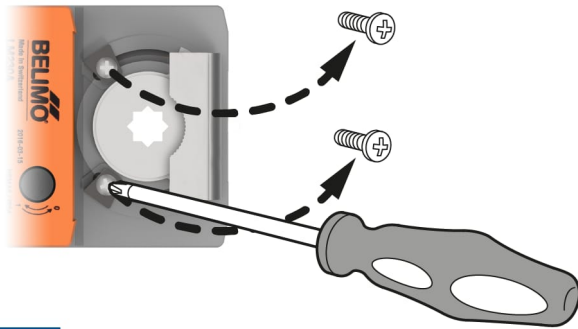

1.

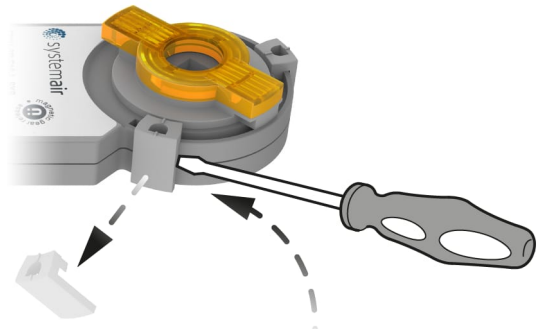

2.

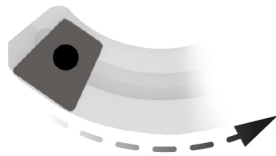

2.

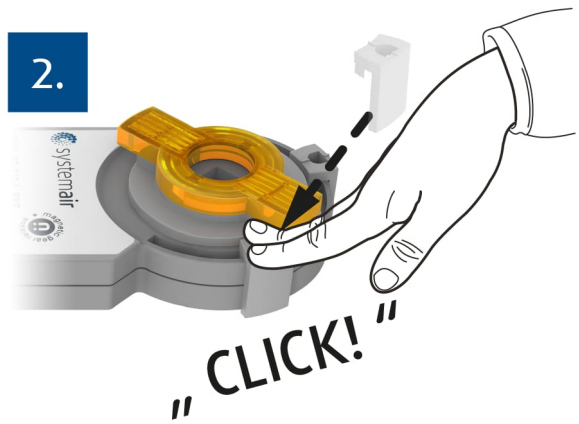

3.

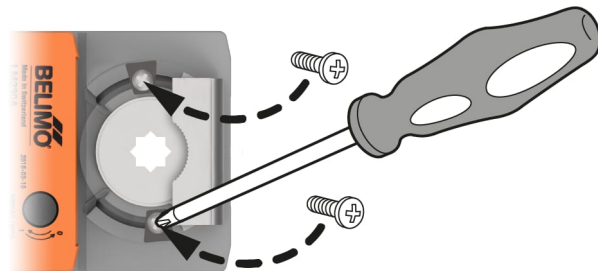

Mitat

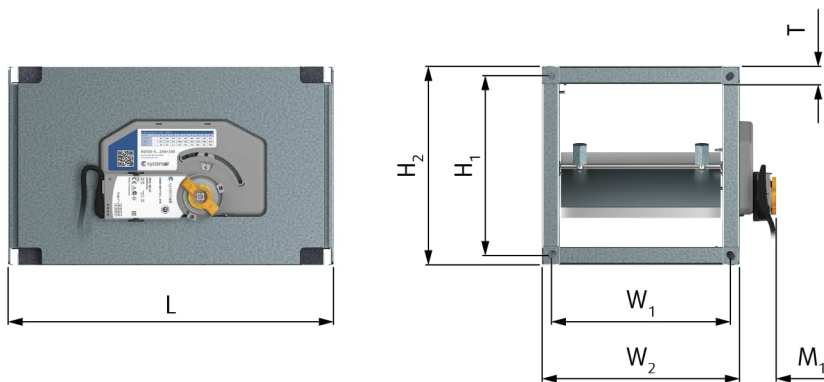
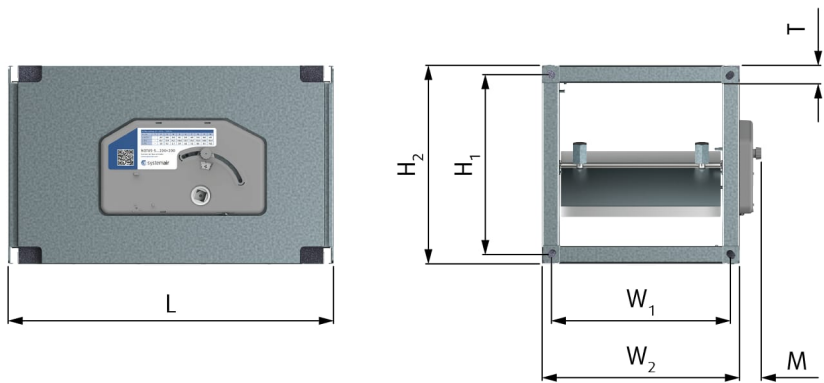
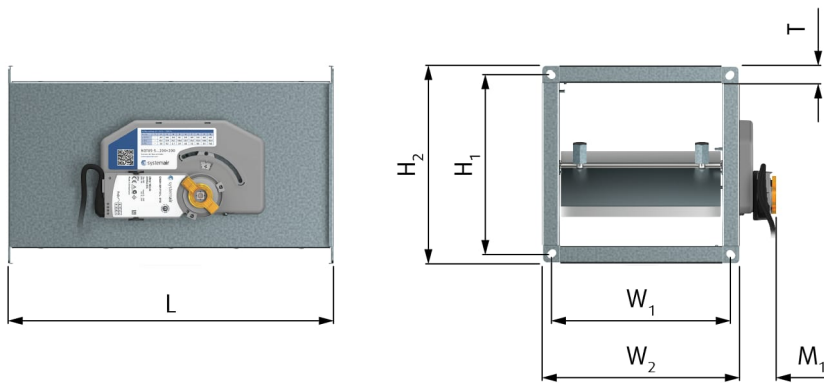
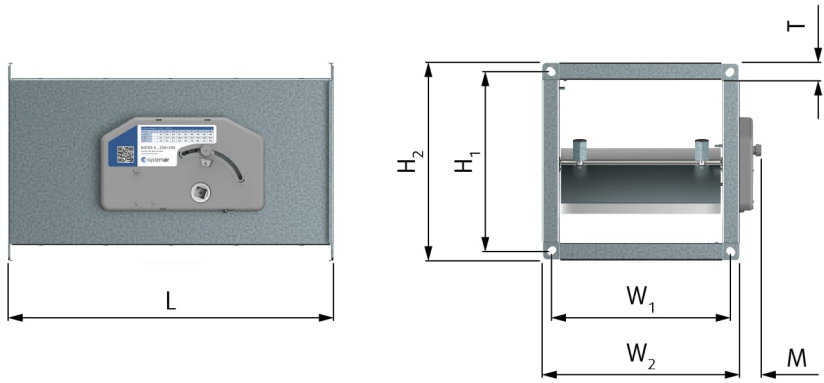

W × H	L	W ₂	W ₁	H ₂	H ₁	T	M	M ₁
mm								
200 × 100	400	243	219	143	119	21,5	25	45
200 × 200				243	219			
300 × 100	400	343	319	143	119	21,5	25	45
300 × 150				193	169			
300 × 200				243	219		30	89
400 × 200	400	443	419	243	219	21,5	30	89
400 × 250				293	269			
400 × 300				343	319			
400 × 400				443	419		65	
500 × 200	400	543	519	243	219	21,5	30	89
500 × 250				293	269			
500 × 300				343	319			
500 × 400				443	419		65	
500 × 500				543	519		-	
600 × 200	400	643	619	243	219	21,5	30	89
600 × 250				293	269			
600 × 300				343	319			
600 × 400				443	419		65	
600 × 500				543	519		-	
600 × 600				643	619		-	

NOTES: The dimension M is valid for NOTUS-S (SI)...M0. The dimension M₁ is valid for NOTUS-S (SI)...M1(M2). Types M1 and M2 are available only in sizes with height (H) smaller than 500 mm (single control mechanism).

Available air flow adjustment types

		H (mm)							
		100	150	200	250	300	400	500	600
W (mm)	200	M0, M1, M2	-	M0, M1, M2	-	-	-	-	-
	300	M0, M1, M2	M0, M1, M2	M0, M1, M2	-	-	-	-	-
	400	-	-	M0, M1, M2	M0, M1, M2	M0, M1, M2	M0, M1, M2	-	-
	500	-	-	M0, M1, M2	M0, M1, M2	M0, M1, M2	M0, M1, M2	M0	-
	600	-	-	M0, M1, M2	M0, M1, M2	M0, M1, M2	M0, M1, M2	M0	M0

Tilauskoodit

NOTUS-S-

Nominal Size (mm)

W x H

Type of Flow Adjustment

M0 Manual

M1 Actuator Operated AC/DC 24 V *

M2 Actuator Operated AC 230 V 2-point

NOTUS-SI-

Nominal Size (mm)

W x H

Type of Flow Adjustment

M0 Manual

M1 Actuator Operated AC/DC 24 V *

M2 Actuator Operated AC 230 V 2-point

NOTES:

* AC/DC 24 V contin. 0 V ... 10 V /2-point

Types M1 and M2 are available only in sizes with height (H) smaller than 500 mm (single control mechanism).

Example of the Ordering Code

NOTUS-SI-200×200-M1

Insulated version of CAV controller with nominal dimensions 200 mm × 200 mm, equipped by actuator type M1.

Lisätarvikkeet

LDR-A

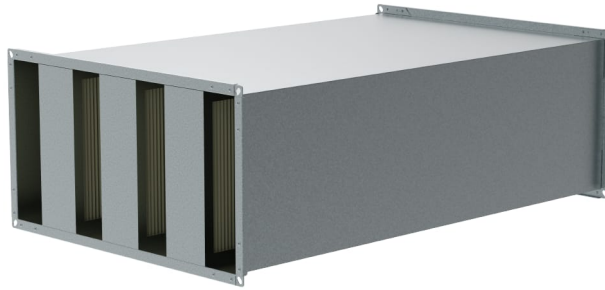

Description

LDR-A is a sound attenuator for rectangular inline devices. The product is intended for installation in rectangular ducts.

Design

LDR-A consists of a frame and attenuation inserts. The frame is manufactured from galvanized steel. The inserts are manufactured from mineral wool.

Product parts

LDR-A...1000

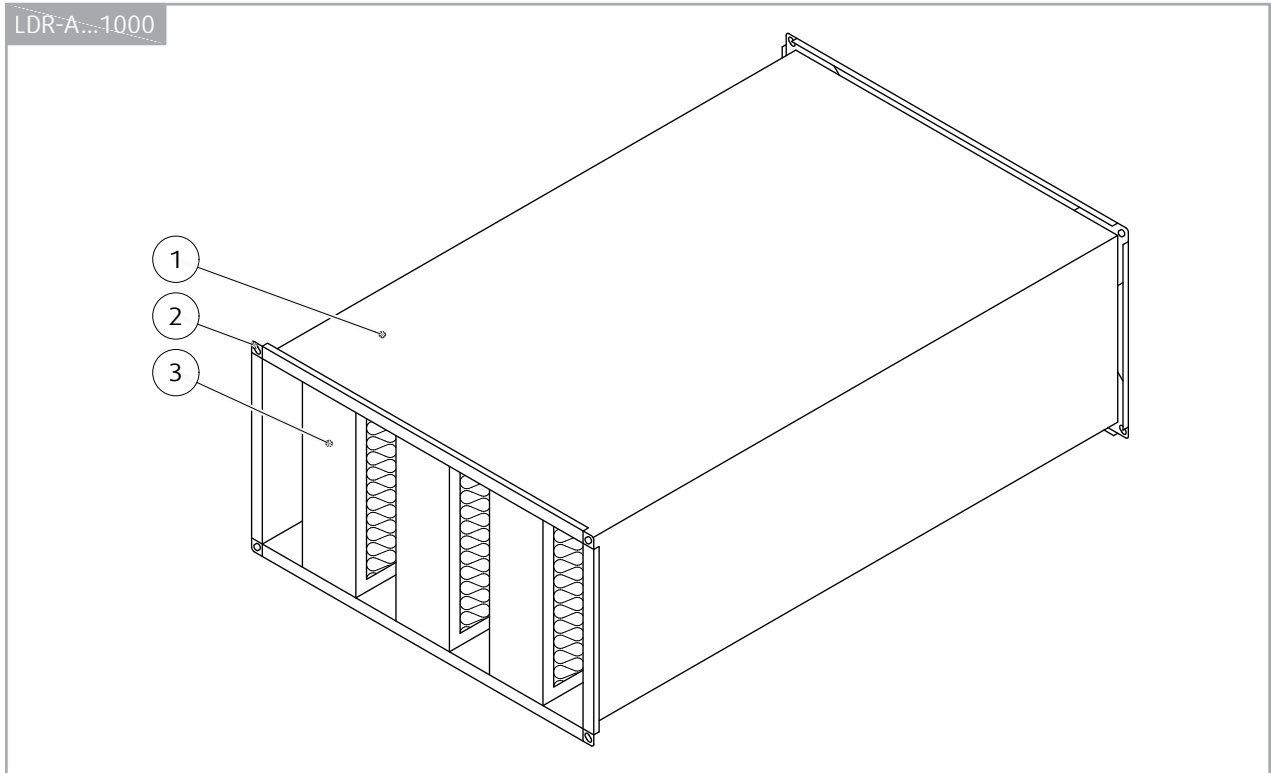

Legend

- P1** - Attenuator casing
- P2** - Connection flange
- P3** - Attenuation baffle

Dimensions

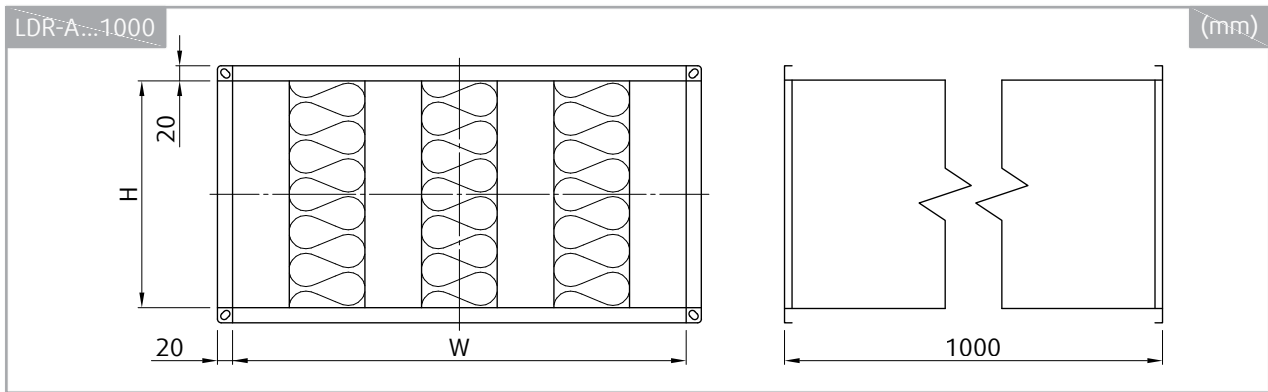

LDR-A			
W	H	L	m
mm			kg
200	100	1000	7,0
	200	1000	10,1
300	100	1000	9,6
	150	1000	10,9
	200	1000	13,7
400	200	1000	17,3
	250	1000	22,4
	300	1000	23,3
	400	1000	25,7
500	200	1000	20,9
	250	1000	26,5
	300	1000	27,4
	400	1000	29,1
	500	1000	32,3
600	200	1000	24,5
	250	1000	30,6
	300	1000	31,5
	400	1000	34,3
	500	1000	36,6
	600	1000	41,1

M1A-NOTUS

Actuator Kit



Description

The actuator kit is intended to upgrade the manually adjusted NOTUS-S (SI)...M0 to the actuator adjusted version M1 on smaller sizes of the CAV controller. It enables remote adjustment of the CAV controller in continuous or in 2-point mode.

Design

The actuator kit consists of the actuator type Belimo CM24-SRV, the gearing and fixing material.

- **Power supply:** AC 24 V
- **Control:** DC 0 V ... 10 V for continuous positioning or AC 24 V for 2-point positioning
- **Power consumption:** 1.5 VA
- **Protection:** IP54

Weight

The weight of the Actuator Kit M1A-NOTUS is 0,4 kg.

Ordering Code

M1A-NOTUS

		H (mm)							
		100	150	200	250	300	400	500	600
W (mm)	200	M1A	-	M1A	-	-	-	-	-
	300	M1A	M1A	M1B	-	-	-	-	-
	400	-	-	M1B	M1B	M1B	M1B	-	-
	500	-	-	M1B	M1B	M1B	M1B	-	-
	600	-	-	M1B	M1B	M1B	M1B	-	-

M1B-NOTUS

Actuator Kit



Description

The actuator kit is intended to upgrade the manually adjusted NOTUS-S (SI)...M0 to the actuator adjusted version M1 on larger sizes of the CAV controller. It enables remote adjustment of the CAV controller in continuous or in 2-point mode.

Design

The actuator kit consists of the actuator type Belimo LM24-SRV, the gearing and fixing material.

- **Power supply:** AC 24 V
- **Control:** DC 0 V ... 10 V for continuous positioning or AC 24V for 2-point positioning
- **Power consumption:** 2 VA
- **Protection:** IP54

Weight

The weight of the Actuator Kit M1B-NOTUS is 0,7 kg.

Ordering Code

M1B-NOTUS

		H (mm)							
		100	150	200	250	300	400	500	600
W (mm)	200	M1A	-	M1A	-	-	-	-	-
	300	M1A	M1A	M1B	-	-	-	-	-
	400	-	-	M1B	M1B	M1B	M1B	-	-
	500	-	-	M1B	M1B	M1B	M1B	-	-
	600	-	-	M1B	M1B	M1B	M1B	-	-

M2A-NOTUS

Actuator Kit



Description

The actuator kit is intended to upgrade the manually adjusted NOTUS-S (SI)...M0 to the actuator adjusted version M1 on smaller sizes of the CAV controller. It enables remote adjustment of the CAV controller in 2-point mode.

Design

The actuator kit consists of the actuator type Belimo CM230, the gearing and fixing material.

- **Power supply:** AC 100 ... 240 V
- **Control:** AC 230 V for 2-point positioning
- **Power consumption:** 3 VA
- **Protection:** IP54

Weight

The weight of the Actuator Kit M2A-NOTUS is 0,4 kg.

Ordering Code

M2A-NOTUS

		H (mm)							
		100	150	200	250	300	400	500	600
W (mm)	200	M2A	-	M2A	-	-	-	-	-
	300	M2A	M2A	M2B	-	-	-	-	-
	400	-	-	M2B	M2B	M2B	M2B	-	-
	500	-	-	M2B	M2B	M2B	M2B	-	-
	600	-	-	M2B	M2B	M2B	M2B	-	-

M2B-NOTUS

Actuator Kit



Description

The actuator kit is intended to upgrade the manually adjusted NOTUS-S (SI)...M0 to the actuator adjusted version M2 on larger sizes of the CAV controller. It enables remote adjustment of the CAV controller in continuous or in 2-point mode.

Design

The actuator kit consists of the actuator type Belimo LM230, the gearing and fixing material.

- **Power supply:** AC 100 ... 240 V
- **Control:** AC 230 V for 2-point positioning
- **Power consumption:** 3.5 VA
- **Protection:** IP54

Weight

The weight of the Actuator Kit M2B-NOTUS is 0,7 kg.

Ordering Code

M2B-NOTUS

		H (mm)							
		100	150	200	250	300	400	500	600
W (mm)	200	M2A	-	M2A	-	-	-	-	-
	300	M2A	M2A	M2B	-	-	-	-	-
	400	-	-	M2B	M2B	M2B	M2B	-	-
	500	-	-	M2B	M2B	M2B	M2B	-	-
	600	-	-	M2B	M2B	M2B	M2B	-	-

Pikavalinta

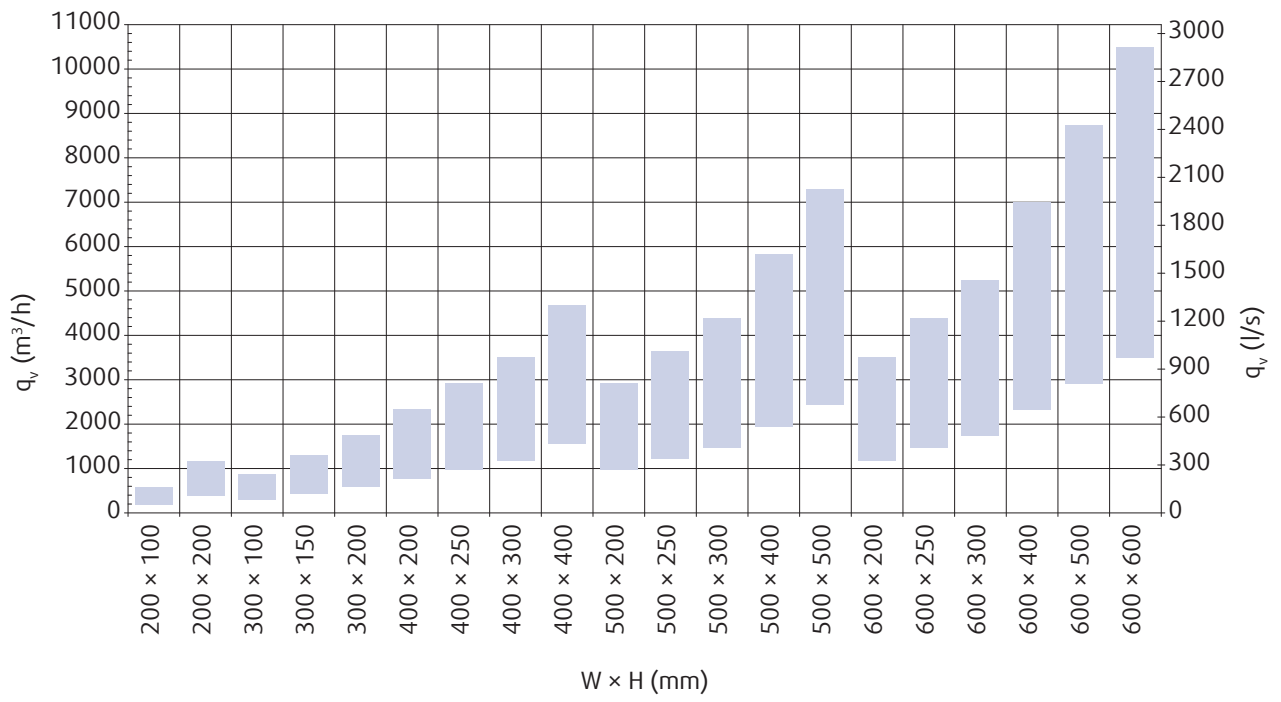

Tekniset parametrit

NOTUS-S-200x100-M0

Painehäviö ja A-painotettu äänitehotaso (dB(A))

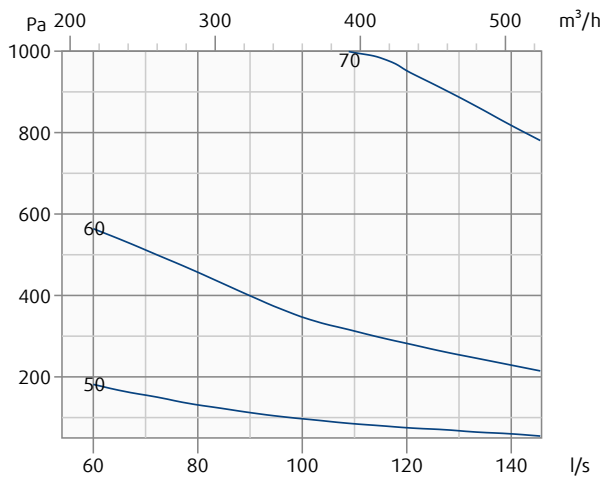

NOTUS-S-200x200-M0

Painehäviö ja A-painotettu äänitehotaso (dB(A))

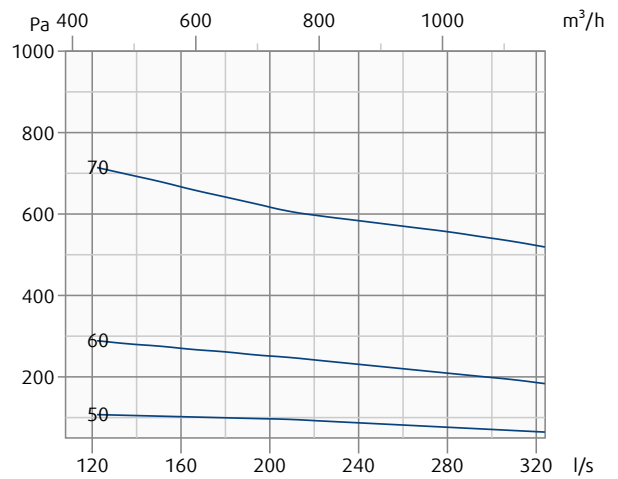

NOTUS-S-300x100-M0

Painehäviö ja A-painotettu äänitehotaso (dB(A))

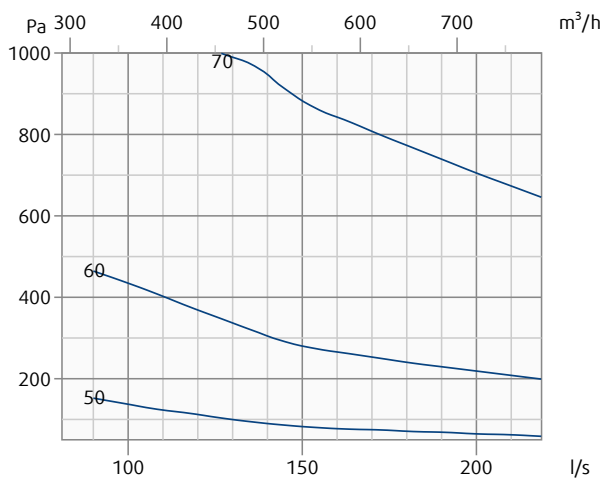

NOTUS-S-300x150-M0

Painehäviö ja A-painotettu äänitehotaso (dB(A))

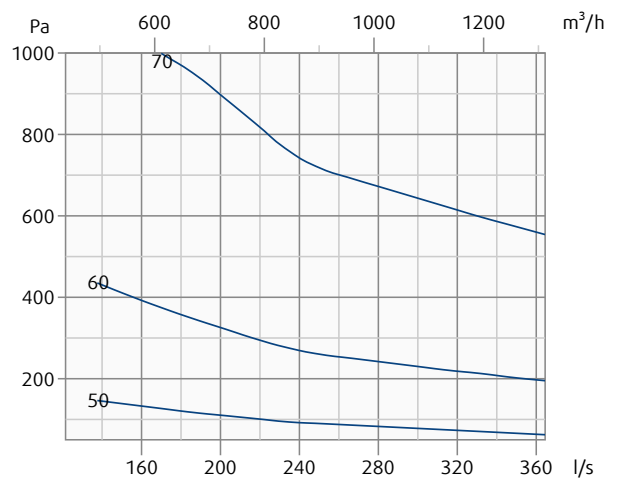

NOTUS-S-300x200-M0

Painehäviö ja A-painotettu äänitehotaso (dB(A))

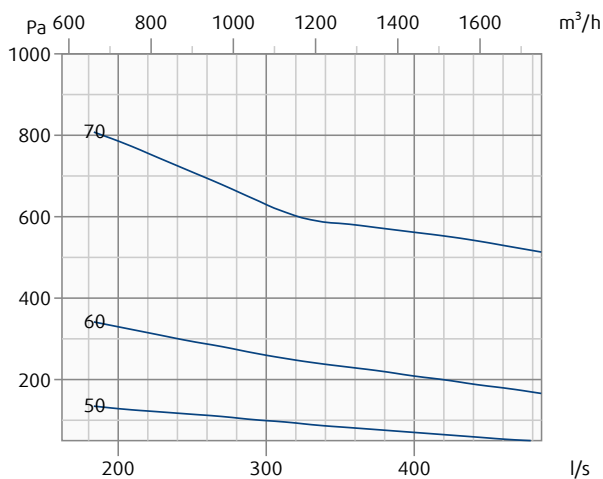

NOTUS-S-400x200-M0

Painehäviö ja A-painotettu äänitehotaso (dB(A))

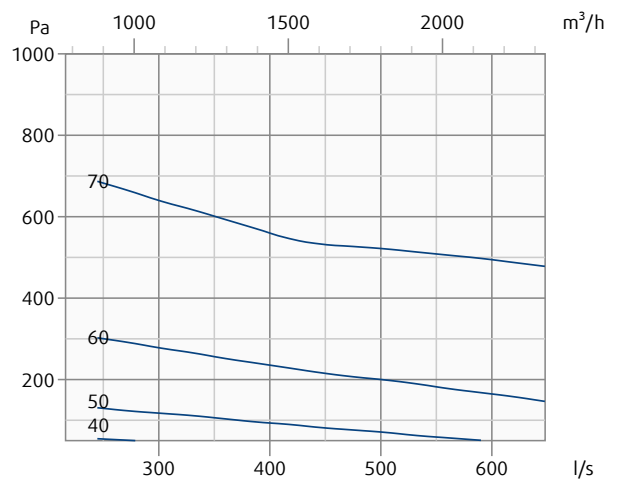

NOTUS-S-400x250-M0

Painehäviö ja A-painotettu äänitehotaso (dB(A))

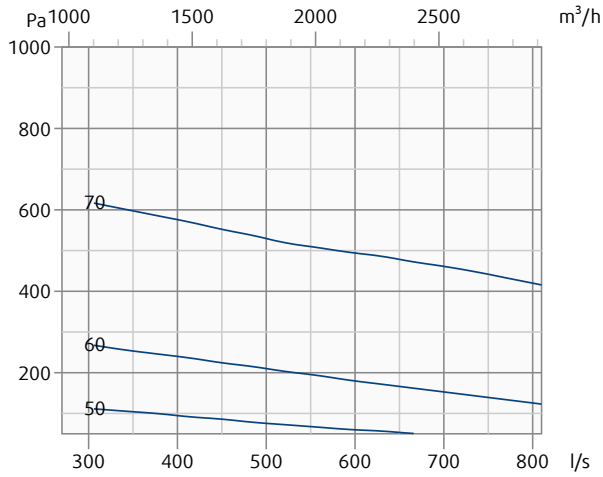

NOTUS-S-400x300-M0

Painehäviö ja A-painotettu äänitehotaso (dB(A))

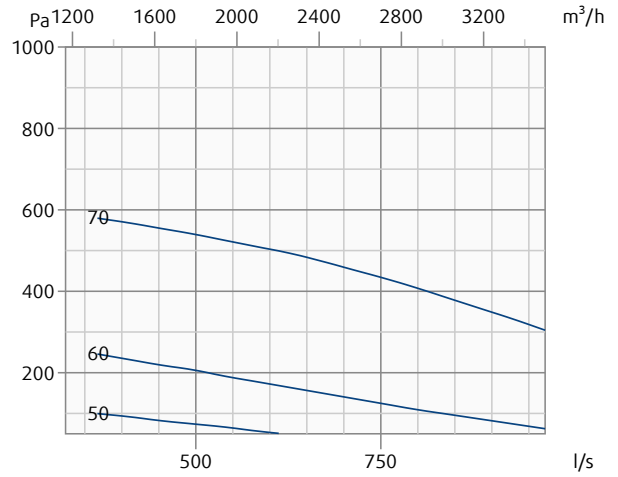

NOTUS-S-400x400-M0

Painehäviö ja A-painotettu äänitehotaso (dB(A))

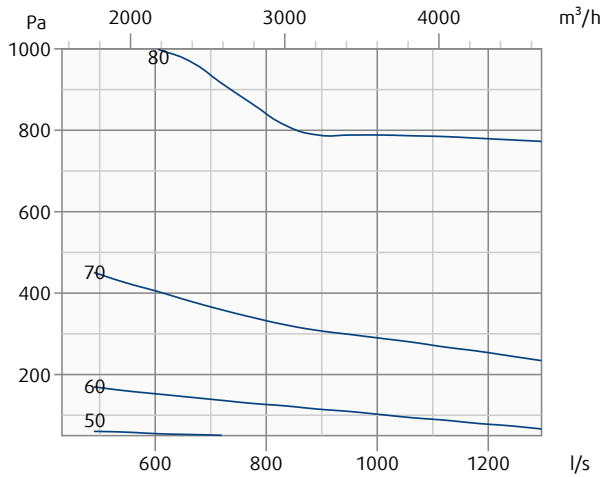

NOTUS-S-500x200-M0

Painehäviö ja A-painotettu äänitehotaso (dB(A))

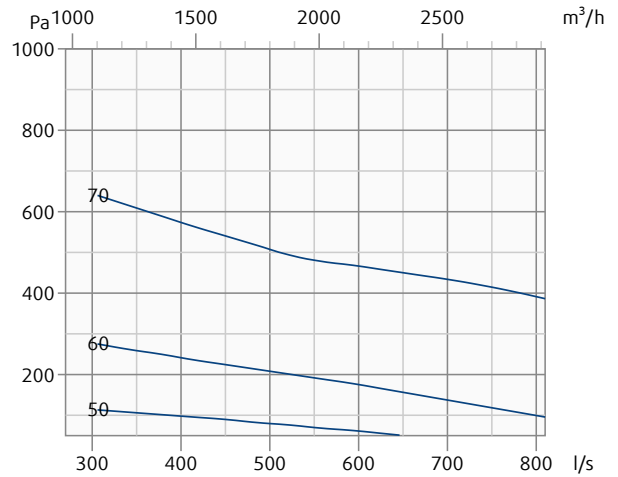

NOTUS-S-500x250-M0

Painehäviö ja A-painotettu äänitehotaso (dB(A))

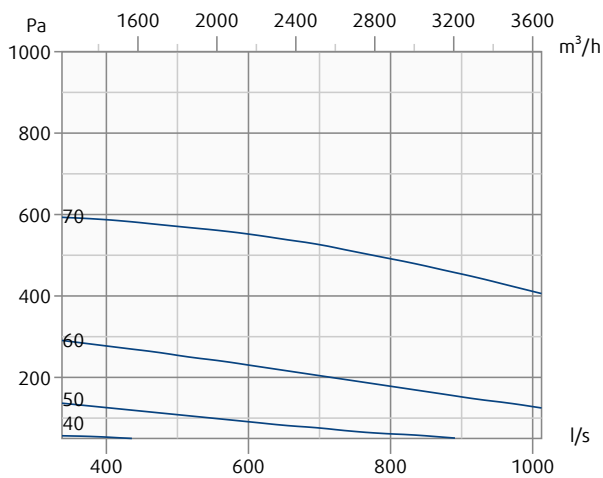

NOTUS-S-500x300-M0

Painehäviö ja A-painotettu äänitehotaso (dB(A))

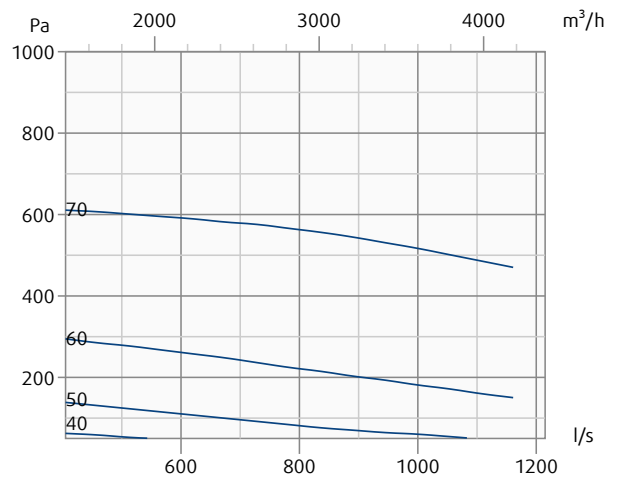

NOTUS-S-500x400-M0

Painehäviö ja A-painotettu äänitehotaso (dB(A))

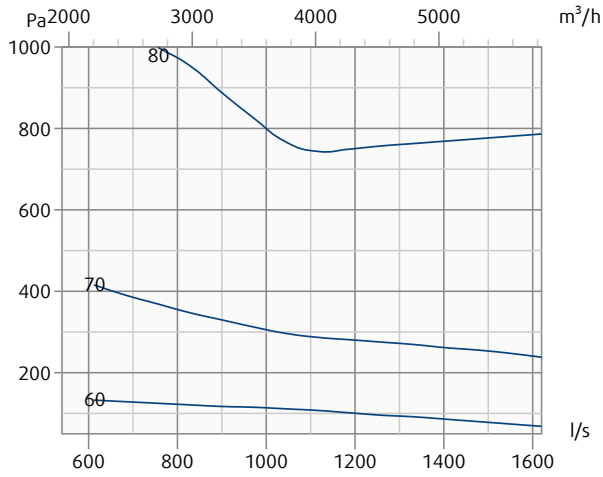

NOTUS-S-500x500-M0

Painehäviö ja A-painotettu äänitehotaso (dB(A))

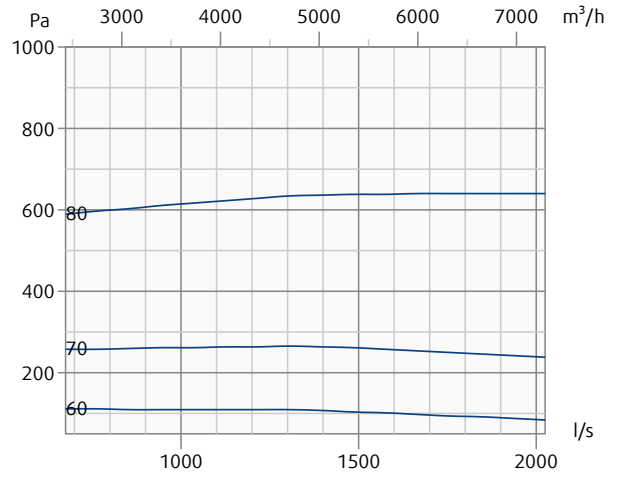

NOTUS-S-600x200-M0

Painehäviö ja A-painotettu äänitehotaso (dB(A))

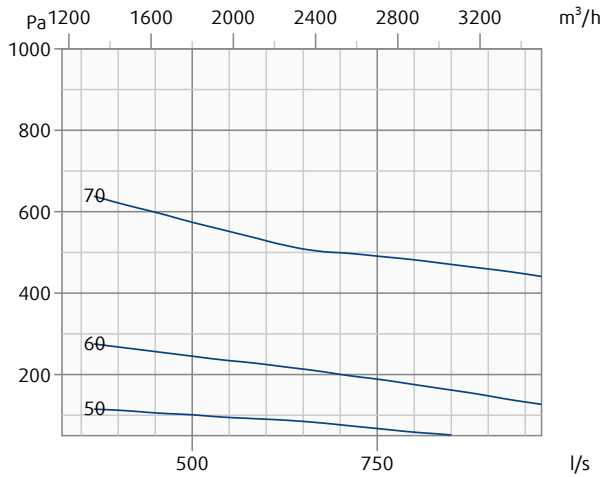

NOTUS-S-600x250-M0

Painehäviö ja A-painotettu äänitehotaso (dB(A))

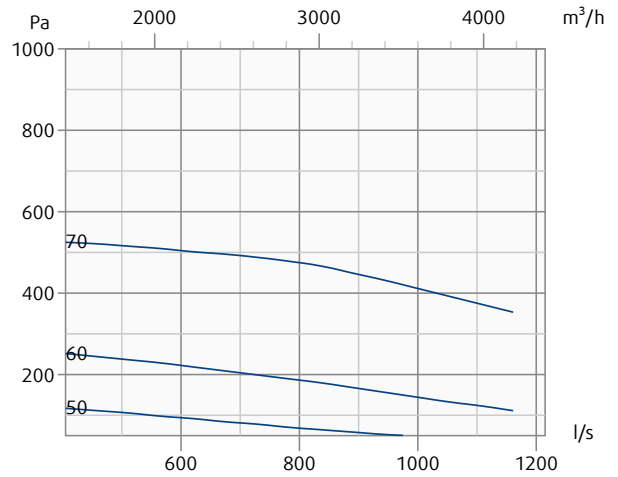

NOTUS-S-600x300-M0

Painehäviö ja A-painotettu äänitehotaso (dB(A))

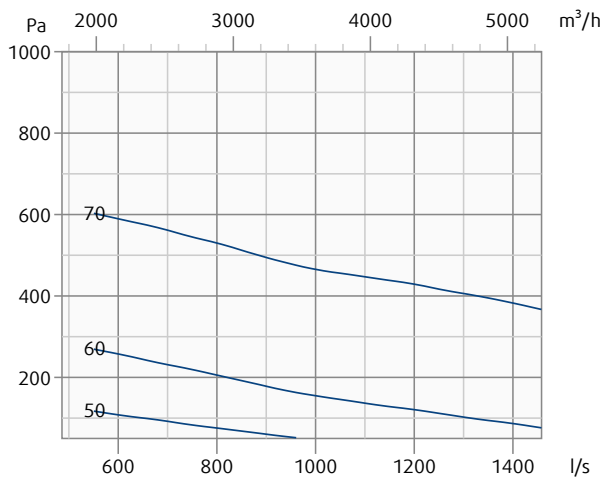

NOTUS-S-600x400-M0

Painehäviö ja A-painotettu äänitehotaso (dB(A))

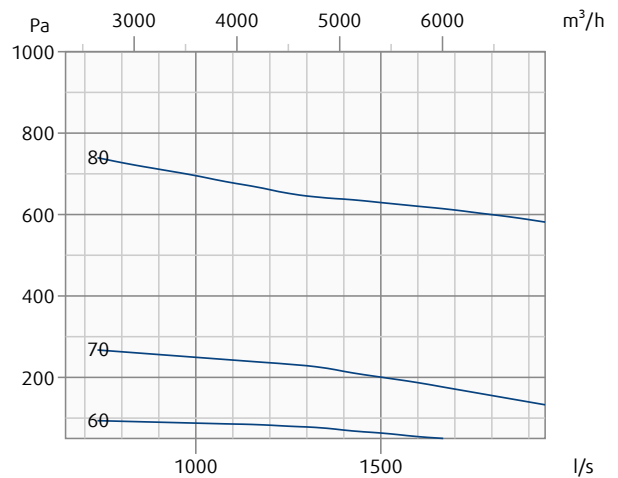

NOTUS-S-600x500-M0

Painehäviö ja A-painotettu äänitehotaso (dB(A))

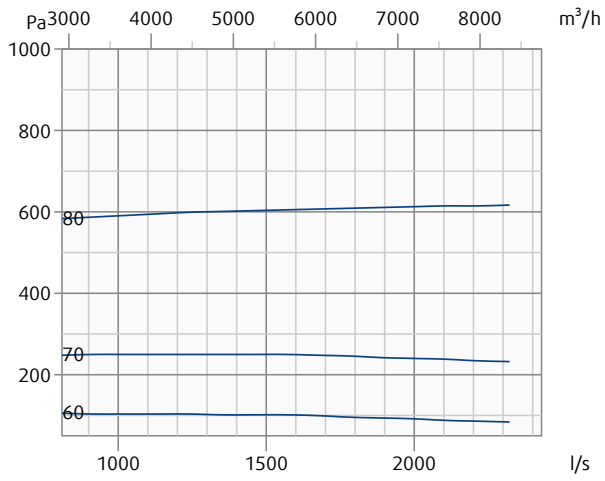

NOTUS-S-600x600-M0

Painehäviö ja A-painotettu äänitehotaso (dB(A))

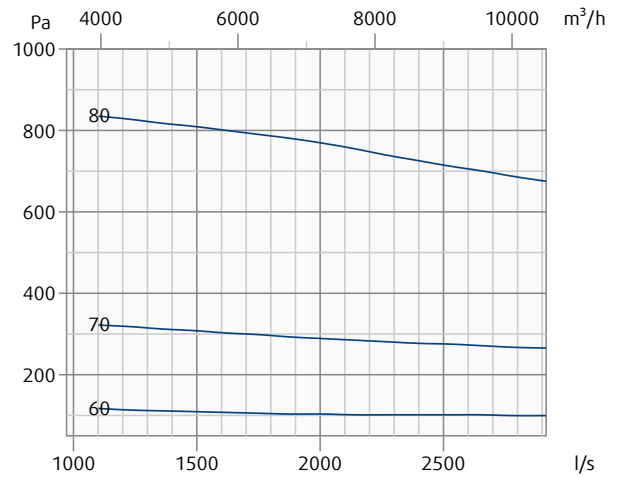

Positioning

NOTUS-S-200×100										
P	1	2,5	3	4	5	6	7	8	9	10
q _v (m ³ /h)	-	205	230	280	330	380	430	480	530	580
q _v (l/s)	-	56,9	63,9	77,8	91,7	105,6	119,4	133,3	147,2	161,1
Y (V)	-	2,3	2,7	3,5	4,4	5,2	6,1	6,9	7,8	9
NOTUS-S-200×200										
P	1	2,75	3	4	5	6	7	8	9	10
q _v (m ³ /h)	-	440	466	571	676	781	886	990	1095	1200
q _v (l/s)	-	122,2	129,5	158,6	187,7	216,9	246	275,1	304,2	333,3
Y (V)	-	2,8	3	3,9	4,7	5,6	6,5	7,3	8,2	9
NOTUS-S-300×100										
P	1	2,25	3	4	5	6	7	8	9	10
q _v (m ³ /h)	-	290	341	410	478	546	615	683	752	820
q _v (l/s)	-	80,6	94,8	113,8	132,8	151,8	170,8	189,8	208,8	227,8
Y (V)	-	2,1	2,7	3,5	4,4	5,2	6,1	7	7,8	9
NOTUS-S-300×150										
P	1	2,25	3	4	5	6	7	8	9	10
q _v (m ³ /h)	-	460	549	668	786	905	1024	1142	1261	-
q _v (l/s)	-	127,8	152,5	185,5	218,4	251,4	284,4	317,3	350,3	-
Y (V)	-	2,4	3	3,9	4,7	5,6	6,5	7,3	8,2	-
NOTUS-S-300×200										
P	1	2,25	3	4	5	6	7	8	9	10
q _v (m ³ /h)	-	590	715	882	1048	1215	1382	1548	1715	-
q _v (l/s)	-	163,9	198,6	244,9	291,2	337,5	383,8	430,1	476,4	-
Y (V)	-	3,2	3,9	4,8	5,6	6,5	7,4	8,2	9,1	-

NOTUS-S-400×200										
P	1	2	3	4	5	6	7	8	9	10
q _v (m ³ /h)	-	-	810	1051	1293	1534	1776	2017	2259	2500
q _v (l/s)	-	-	225	292,1	359,1	426,2	493,3	560,3	627,4	694,4
Y (V)	-	-	3,7	4,6	5,5	6,4	7,2	8,1	9	10
NOTUS-S-400×250										
P	1	2,5	3	4	5	6	7	8	9	10
q _v (m ³ /h)	-	930	1068	1344	1620	1896	2172	2448	2724	3000
q _v (l/s)	-	258,3	296,7	373,3	450	526,7	603,3	680	756,7	833,3
Y (V)	-	3,5	3,9	4,8	5,7	6,5	7,4	8,3	9,2	10
NOTUS-S-400×300										
P	1	2	3	4	5	6	7	8	9	10
q _v (m ³ /h)	-	-	1120	1460	1800	2140	2480	2820	3160	3500
q _v (l/s)	-	-	311,1	405,6	500	594,4	688,9	783,3	877,8	972,2
Y (V)	-	-	3,9	4,8	5,6	6,5	7,4	8,3	9,1	10
NOTUS-S-400×400										
P	1	2,75	3	4	5	6	7	8	9	10
q _v (m ³ /h)	-	1550	1669	2145	2621	3096	3572	4048	4524	5000
q _v (l/s)	-	430,6	463,6	595,8	727,9	860,1	992,3	1124,4	1256,6	1388,8
Y (V)	-	3,5	3,7	4,6	5,5	6,4	7,3	8,2	9,1	10
NOTUS-S-500×200										
P	1	2	3	4	5	6	7	8	9	10
q _v (m ³ /h)	-	-	870	1246	1621	1997	2373	2749	3124	3500
q _v (l/s)	-	-	241,7	346	450,4	554,8	659,1	763,5	867,9	972,2
Y (V)	-	-	3,6	4,5	5,4	6,3	7,2	8,1	9	10

NOTUS-S-500×250										
P	1	2,75	3	4	5	6	7	8	9	10
q _v (m ³ /h)	-	1200	1300	1700	2100	2500	2900	3300	3700	4100
q _v (l/s)	-	333,3	361,1	472,2	583,3	694,4	805,6	916,7	1027,8	1138,9
Y (V)	-	3,5	3,7	4,6	5,5	6,4	7,3	8,2	9,1	10
NOTUS-S-500×300										
P	1	2	3,25	4	5	6	7	8	9	10
q _v (m ³ /h)	-	-	1400	1711	2126	2541	2956	3370	3785	4200
q _v (l/s)	-	-	388,9	475,3	590,5	705,8	821	936,2	1051,4	1166,7
Y (V)	-	-	3,9	4,6	5,5	6,4	7,3	8,1	9	10
NOTUS-S-500×400										
P	1	2	3	4	5	6	7	8	9	10
q _v (m ³ /h)	-	-	1950	2550	3150	3750	4350	4950	5550	6150
q _v (l/s)	-	-	541,7	708,3	875	1041,7	1208,3	1375	1541,7	1708,3
Y (V)	-	-	3,7	4,6	5,5	6,4	7,3	8,2	9	10
NOTUS-S-500×500										
P	1	2,75	3	4	5	6	7	8	9	10
q _v (m ³ /h)	-	2430	2598	3268	3938	4609	5279	5949	6620	7290
q _v (l/s)	-	675	721,6	907,8	1094	1280,2	1466,4	1652,6	1838,8	2025
Y (V)	-	-	-	-	-	-	-	-	-	-
NOTUS-S-600×200										
P	1	2,5	3	4	5	6	7	8	9	10
q _v (m ³ /h)	-	1175	1350	1700	2050	2400	2750	3100	3450	3800
q _v (l/s)	-	326,4	375	472,2	569,4	666,7	763,9	861,1	958,3	1055,6
Y (V)	-	3,4	3,8	4,7	5,6	6,5	7,4	8,2	9,1	10

NOTUS-S-600×250										
P	1	2,75	3	4	5	6	7	8	9	10
q _v (m ³ /h)	-	1450	1566	2028	2490	2952	3414	3876	4338	4800
q _v (l/s)	-	402,8	434,9	563,2	691,6	819,9	948,3	1076,6	1205	1333,3
Y (V)	-	3,6	3,8	4,7	5,5	6,4	7,3	8,2	9,1	10
NOTUS-S-600×300										
P	1	2	3,25	4	5	6	7	8	9	10
q _v (m ³ /h)	-	-	1750	2122	2619	3115	3611	4107	4603,7	5100
q _v (l/s)	-	-	486,1	589,5	727,4	865,2	1003,1	1140,9	1278,8	1416,7
Y (V)	-	-	4,2	4,7	5,5	6,4	7,3	7,7	9,1	10
NOTUS-S-600×400										
P	1	2	3,25	4	5	6	7	8	9	10
q _v (m ³ /h)	-	-	2350	2867	3556	4244	4933	5622	6311	7000
q _v (l/s)	-	-	652,8	796,3	987,7	1179	1370,4	1561,7	1753,1	1944,4
Y (V)	-	-	4	4,7	5,6	6,5	7,4	8,2	9,1	10
NOTUS-S-600×500										
P	1	2	3	4	5	6	7	8	9	10
q _v (m ³ /h)	-	-	3050	3957	4864	5771	6679	7586	8493	9400
q _v (l/s)	-	-	847,2	1099,2	1351,2	1603,2	1855,2	2107,1	2359,1	2611,1
Y (V)	-	-	-	-	-	-	-	-	-	-
NOTUS-S-600×600										
P	1	2	3,25	4	5	6	7	8	9	10
q _v (m ³ /h)	-	-	3500	4244	5237	6230	7222	8215	9207	10200
q _v (l/s)	-	-	972,2	1179	1454,7	1730,5	2006,2	2281,9	2557,6	2833,3
Y (V)	-	-	-	-	-	-	-	-	-	-

Asennus

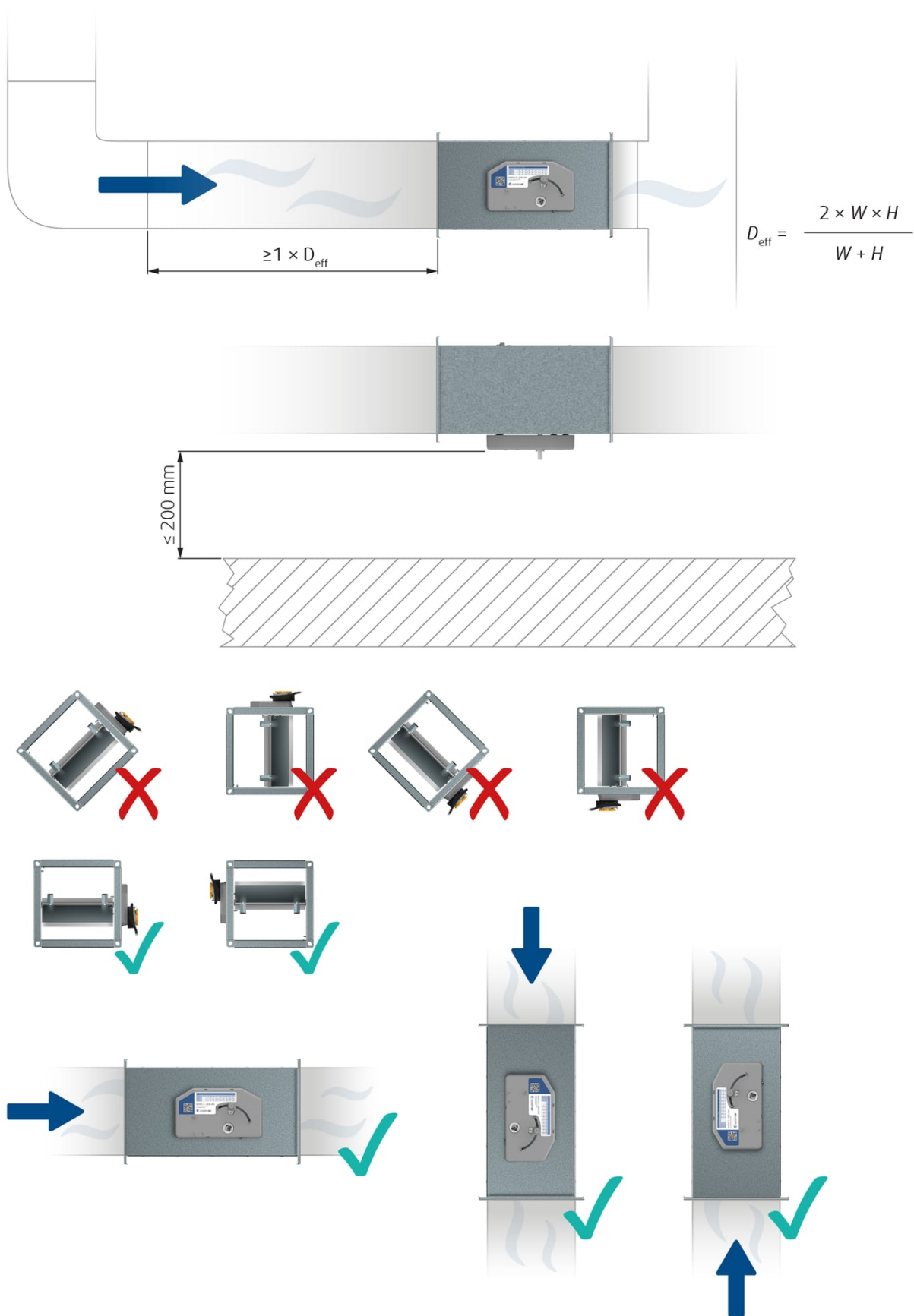

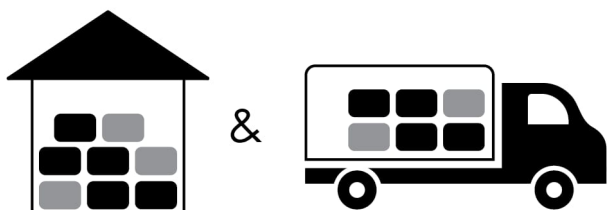

Kuljetus, varastointi ja käyttö

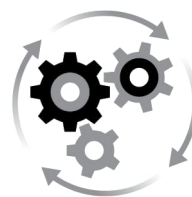

 °C -40 °C ... +80 °C

 % ≤ 95%



 °C -20 °C ... +70 °C

 % ≤ 95%

Muutokset

Any deviations from the technical specifications contained herein and the terms should be discussed with the manufacturer. We reserve the right to make any changes to the product without prior notice, provided that these changes do not affect the quality of the product and the required parameters. Current information on all products is available on design.systemair.com.



Handbook_NOTUS_S_fi-FI
design.systemair.com
www.systemair.com

© Copyright Systemair Production a.s
Kaikki oikeudet pidätetään
E&OE

Systemair pidättää oikeuden muuttaa tuotteitaan ilman ennakoilmoitusta.
Tämä koskee myös jo tilattuja tuotteita, niin kauan kuin se ei vaikuta aiemmin sovittuihin eritelmiin.