

TSF
Extract Diffuser
Handbook



Table of Contents

Description3
Dimensions & Weights5
Ordering Codes6
Accessory7
Technical Parameters9
Installation12
Transport, Storage and Operation21
Supplement22



Description

TSF is a square extract diffuser, designed for ceiling assembly. It has a perforated front plate and is mainly intended for air extract, but can be also used for air supply. The product is intended for use as air supply diffuser in offices, schools, hospitals etc.

Accessory:

- THOR: Plenum Box

Design

The TSF is manufactured from steel with a white powder-coated finish and is available in 7 sizes. It consists of backing box and a perforated diffuser plate. The backing box has a connection sleeve fitted with a rubber gasket. The diffuser plate is removable to easy access to the duct.

Product Parts

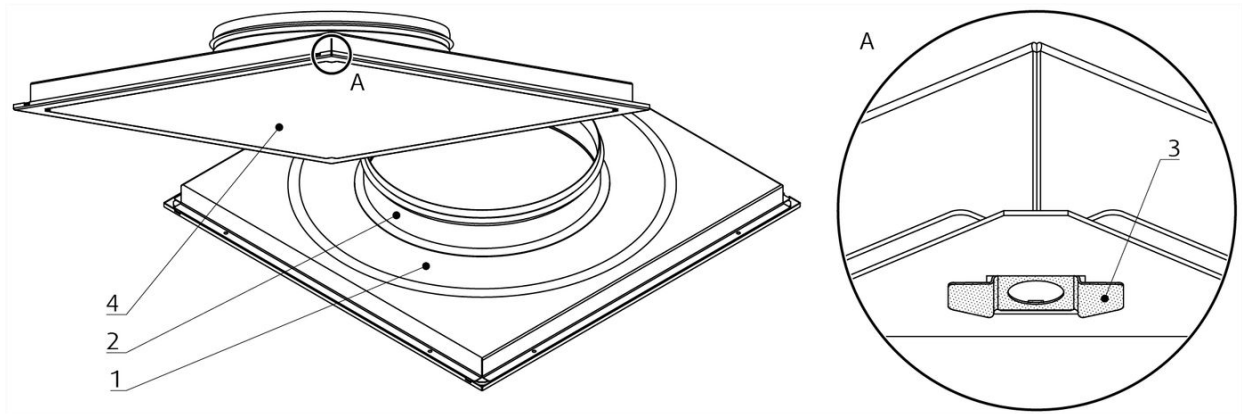

Legend

- 1 Backing box
- 2 Connection with rubber gasket
- 3 Spring clips for diffuser plate fixing (inside the backing box)
- 4 Diffuser plate

Dimensions & Weights

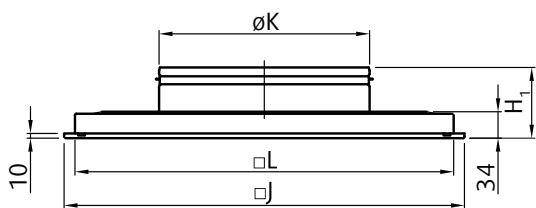

DN	$\varnothing K$	$\square J$	$\square L$	H_1	m
	mm				kg
100	99	355	326	93	2,3
125	124	355	326	93	2,2
160	159	355	326	93	2,2
200	199	455	426	100	3,6
250	249	565	561	100	6,1
315	314	595	561	100	5,9
400	399	595	561	120	5,0

Ordering Codes

Size - inlet ø (mm)

100

125

160

200

250

315

400

Surface finish

SW Signal white (RAL9003, gloss 30%)

RALxxxx Other colour powder coating

Example of the Ordering Code

TSF-250-SW

Diffuser of connection size 250 mm, signal white RAL9003

Notes: If no surface finish is stated in ordering code, the product will be delivered in signal white RAL9003.

Accessory

THOR

Plenum Box



Description

The THOR plenum box is used together with air diffusers for pressure reduction, airflow balancing and sound attenuation as well as for measuring and adjusting the air flow. The plenum box can be used for air inlet and extract.

Design

THOR plenum boxes are manufactured from hot-dip galvanized sheet steel with inlet connection sleeve fitted with a rubber seal tested for air-tightness. The inlet is equipped by the ZEUS damper with impulse tubes for measuring differential pressure for flow volume calculation, using a portable measuring device. It can be adjusted manually using a cable gearing.

Dimensions

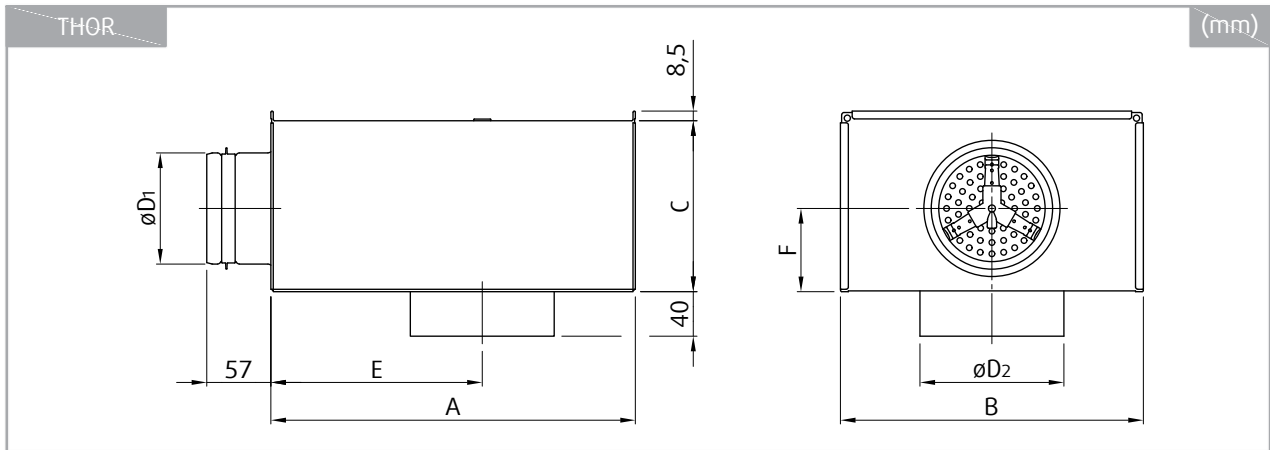

THOR	A	B	C	$\varnothing D_1$	$\varnothing D_2$	E	F	m
	mm							kg
100-125	320	267	150	98	126	185	75	2,5
125-160	360	267	160	123	161	210	80	2,9
160-200	450	317	195	158	201	280	98	4,0
200-250	500	367	250	198	251	305	125	5,4
250-315	565	467	300	248	316	330	150	7,3
315-400	620	567	400	313	401	360	200	10,1

Ordering Codes

Nominal size: Inlet-Outlet

100-125

125-160

160-200

200-250

250-315

315-400

Example of the Ordering Code

THOR-100-125

Plenum box THOR with 100 mm circular inlet and 125 mm circular outlet (nominal dimensions).

Technical Parameters

Legend

p_s (Pa) Pressure drop

q_v (m³/h or l/s) Air flow volume

L_{WA} (dB(A)) A-weighted total radiated sound power level

L_{pA} (dB(A)) A-weighted total sound pressure level expressed for 10 m² room absorption area

L_W (dB) Non weighted total sound power level

$L_{0,2}$ (m) Air throw length with terminal velocity 0,2 m/s

L_x (m) Air throw length calculated for specific terminal velocity

x (m/s) Terminal velocity in range of 0,1 m/s ... 1 m/s

Calculation of Air Throw for Different Terminal Velocities

$$L_x = L_{0,2} \cdot 0,2/x$$

Pressure drop and radiated sound power level dependent on air flow volume

TSF-100-SW

Pressure drop & A-weighted sound power level in dB(A)

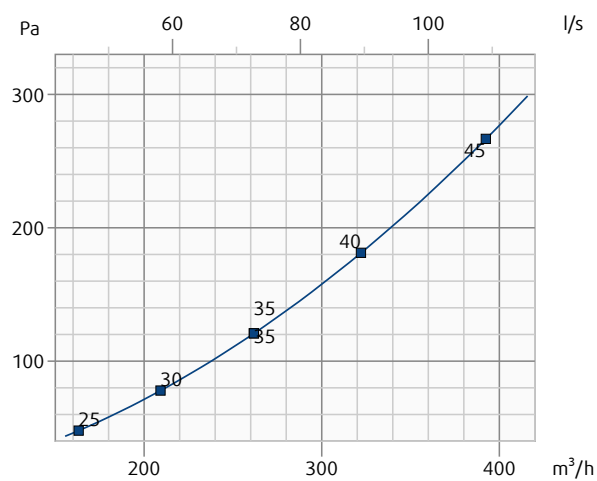

Pressure drop and radiated sound power level dependent on air flow volume

TSF-125-SW

Pressure drop & A-weighted sound power level in dB(A)

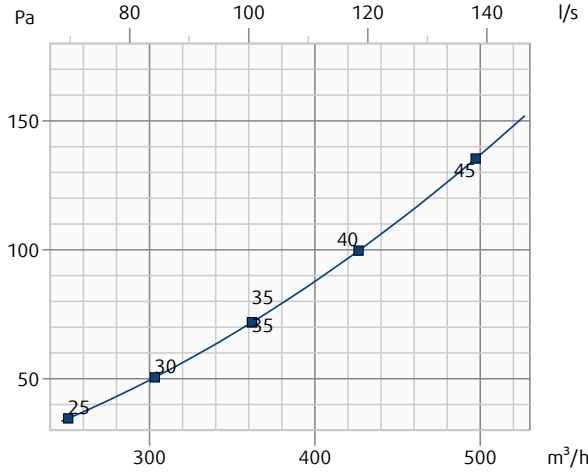

TSF-125-SW + THOR-100-125

Pressure drop & A-weighted sound power level in dB(A)

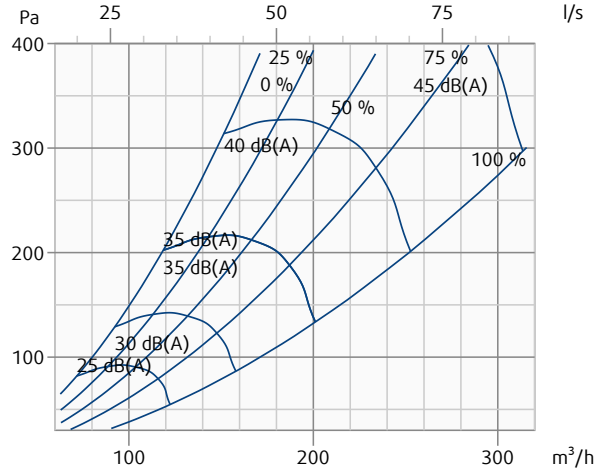

TSF-160-SW

Pressure drop & A-weighted sound power level in dB(A)

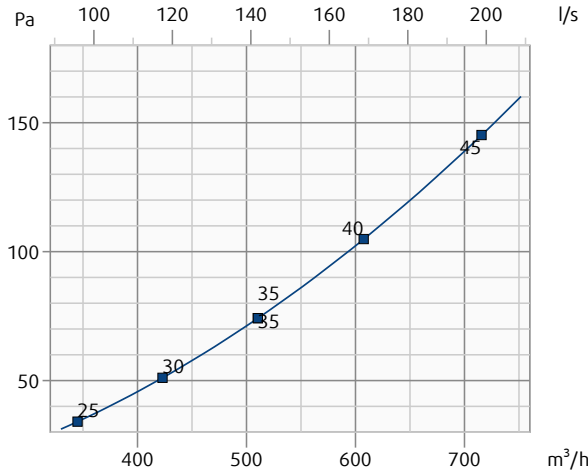

TSF-160-SW + THOR-125-160

Pressure drop & A-weighted sound power level in dB(A)

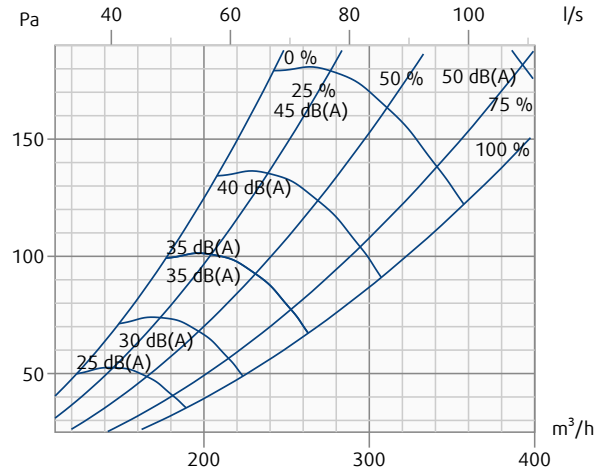

TSF-200-SW

Pressure drop & A-weighted sound power level in dB(A)

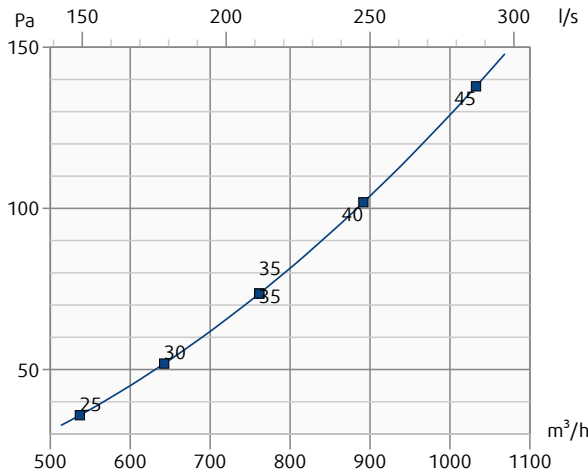

TSF-200-SW + THOR-160-200

Pressure drop & A-weighted sound power level in dB(A)

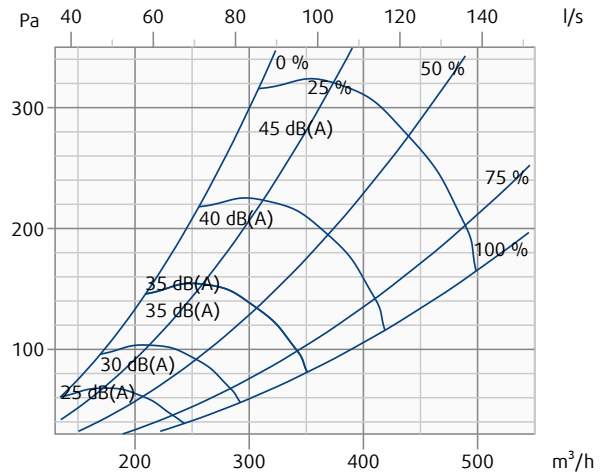

TSF-250-SW

Pressure drop & A-weighted sound power level in dB(A)

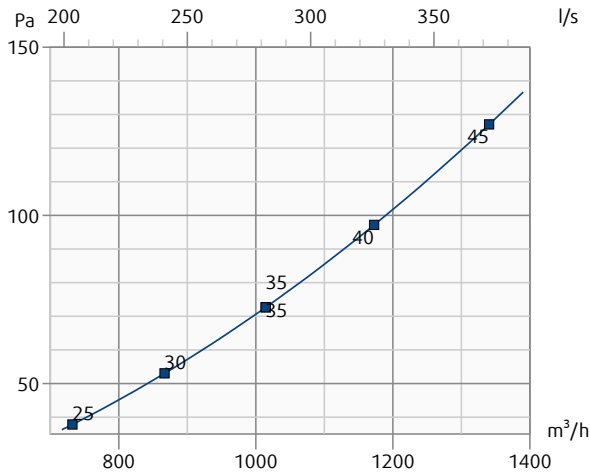

TSF-250-SW + THOR-200-250

Pressure drop & A-weighted sound power level in dB(A)

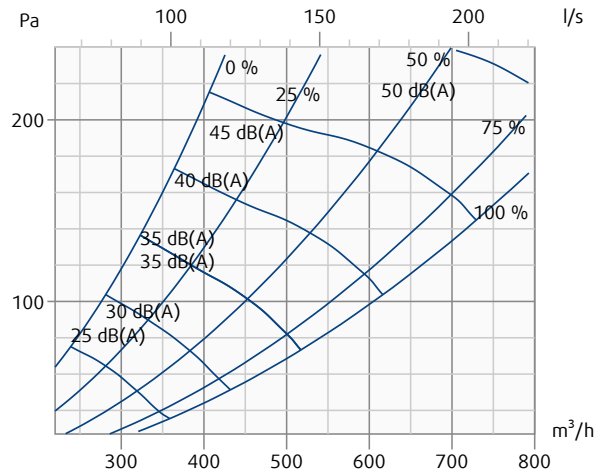

TSF-315-SW

Pressure drop & A-weighted sound power level in dB(A)

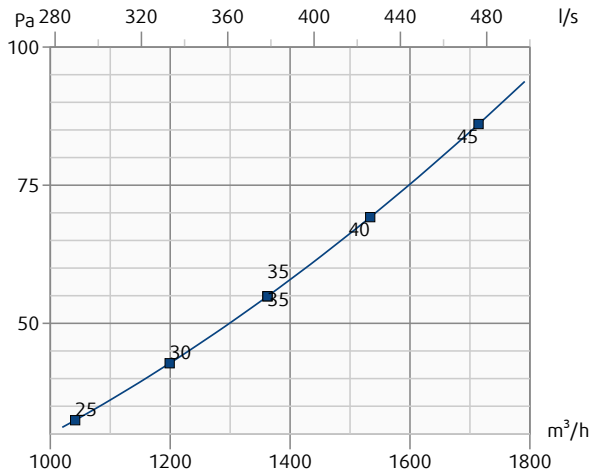

TSF-315-SW + THOR-250-315

Pressure drop & A-weighted sound power level in dB(A)

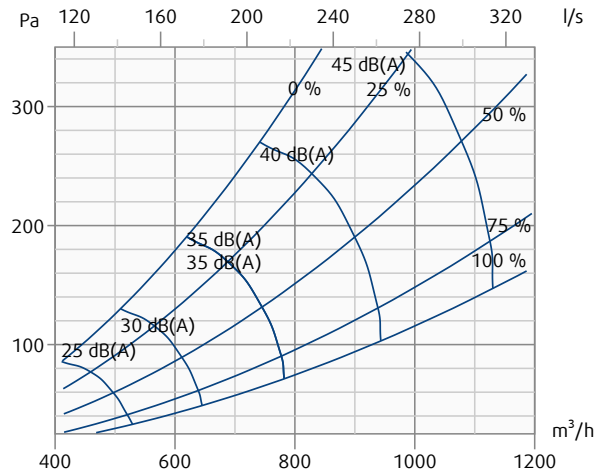

TSF-400-SW

Pressure drop & A-weighted sound power level in dB(A)

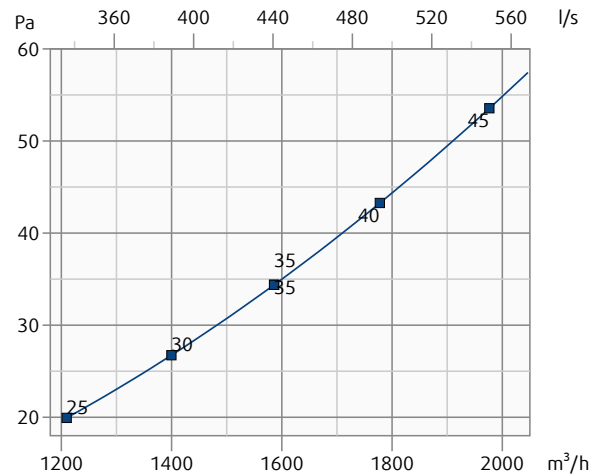

TSF-400-SW + THOR-315-400

Pressure drop & A-weighted sound power level in dB(A)

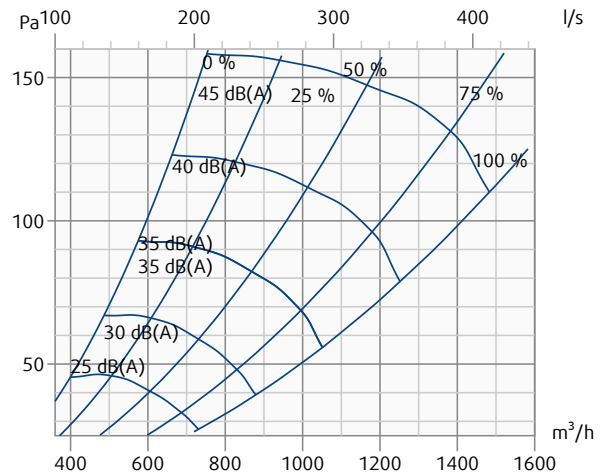

Installation

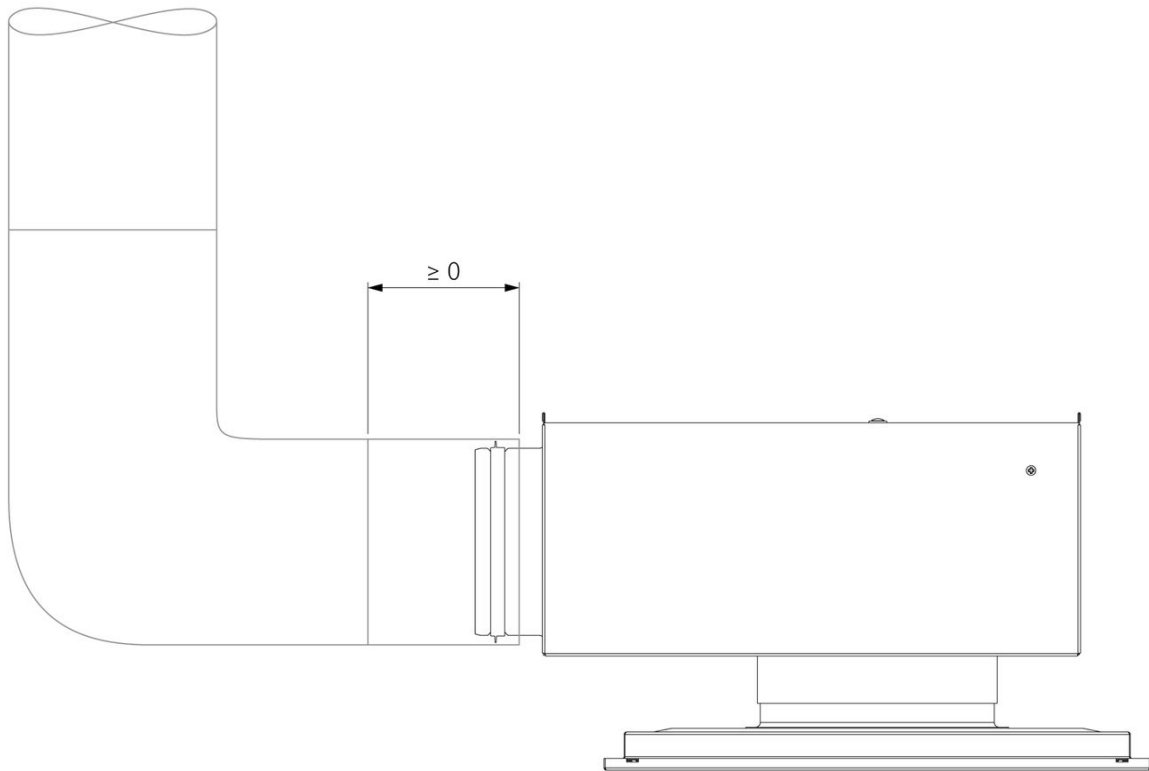
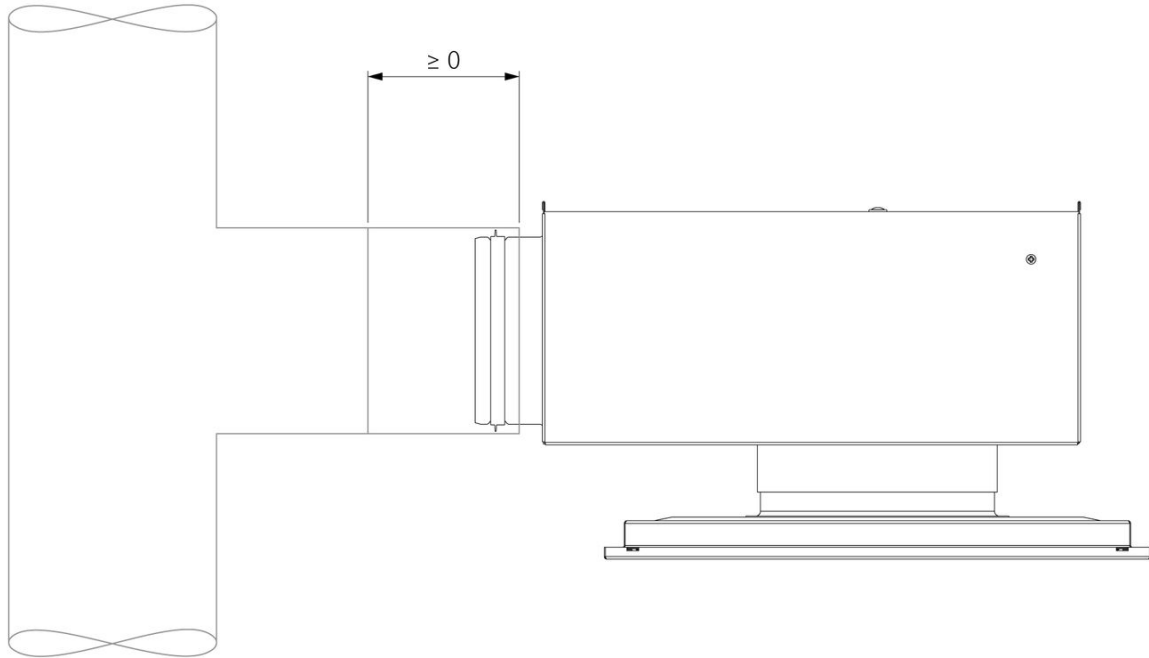

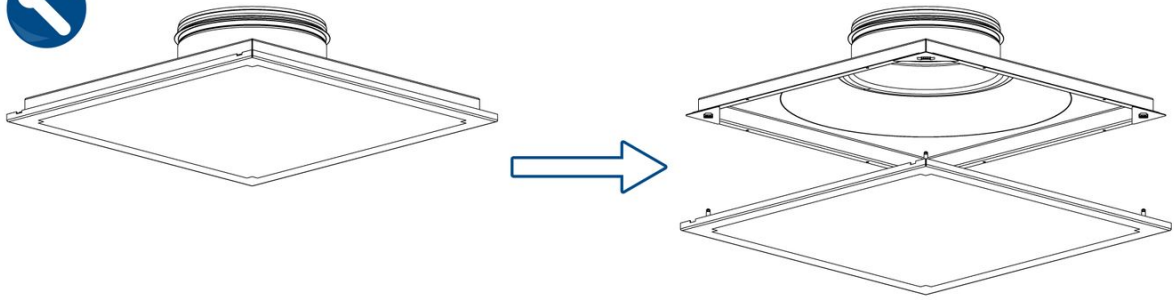

1.

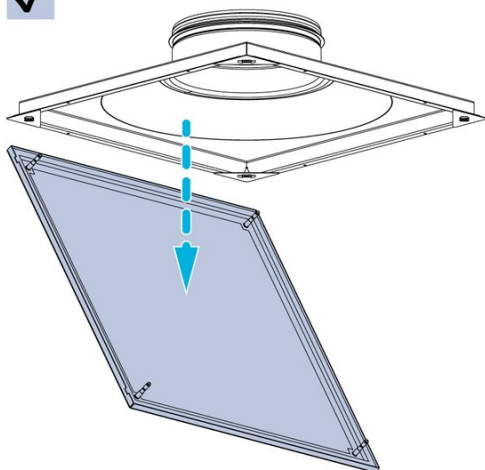
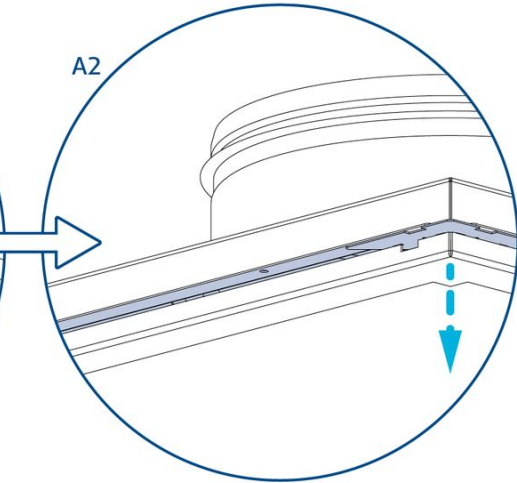
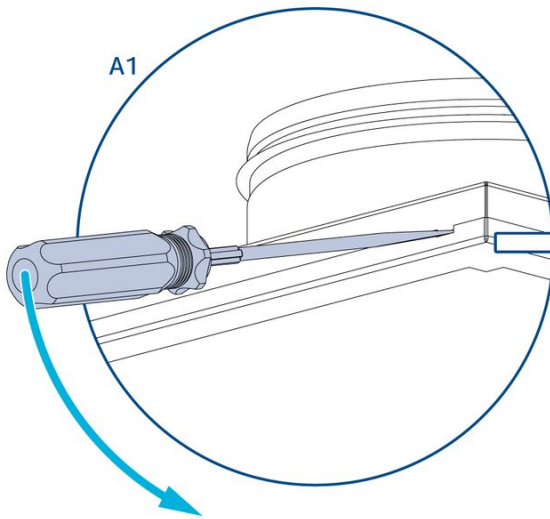
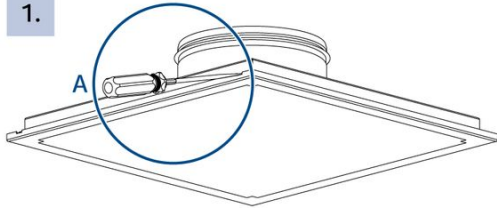

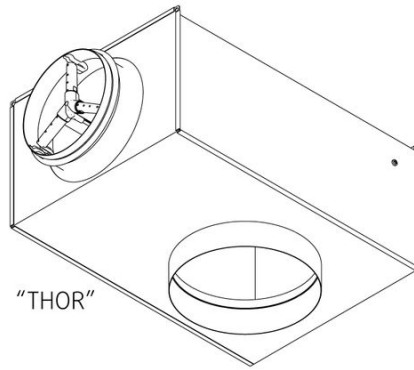

2.

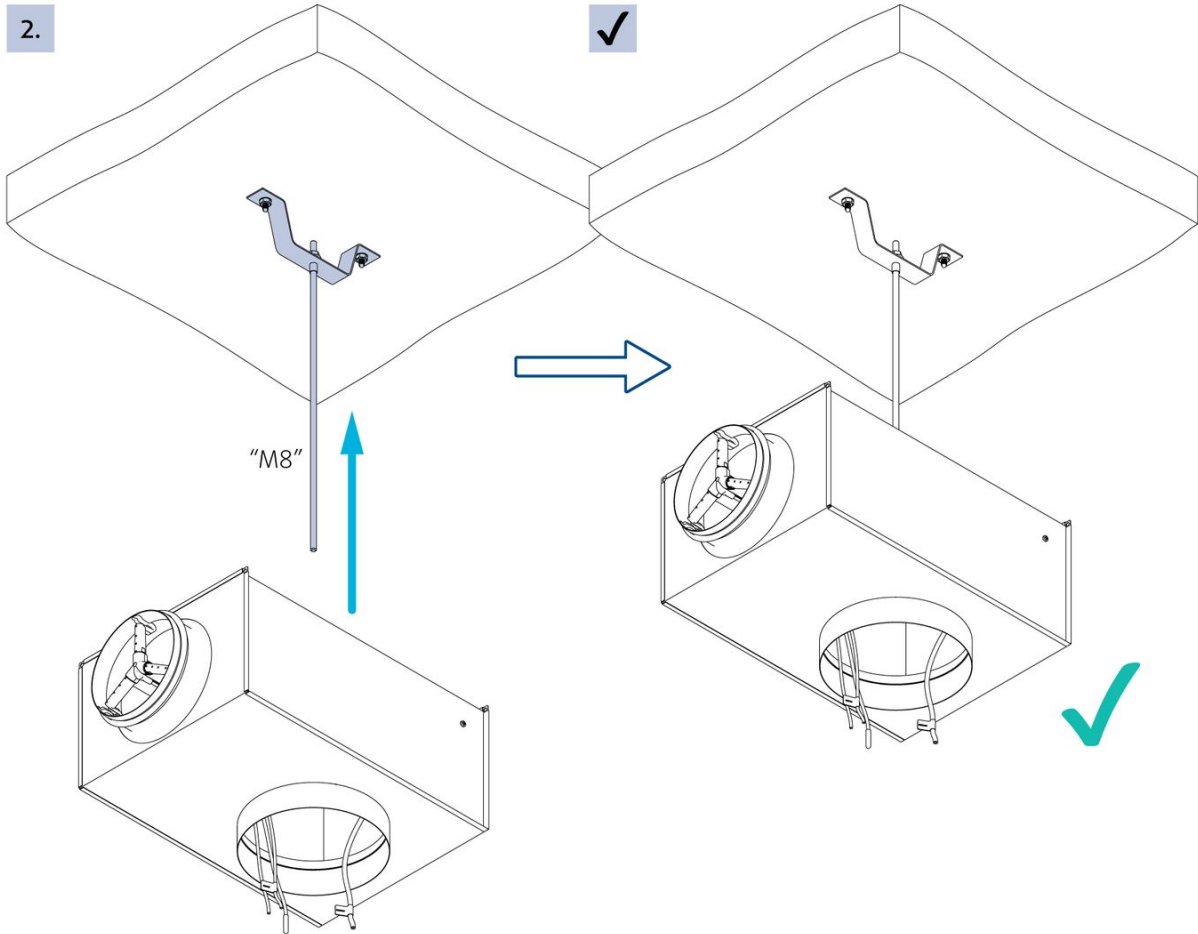

3.

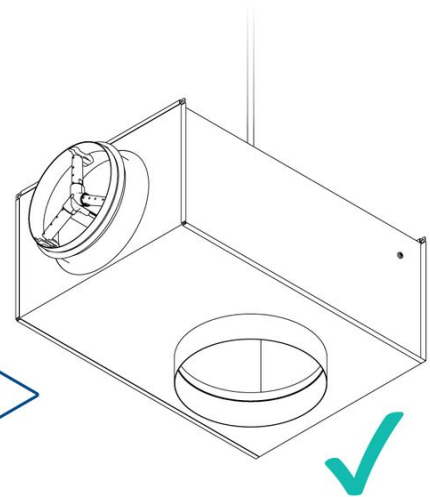
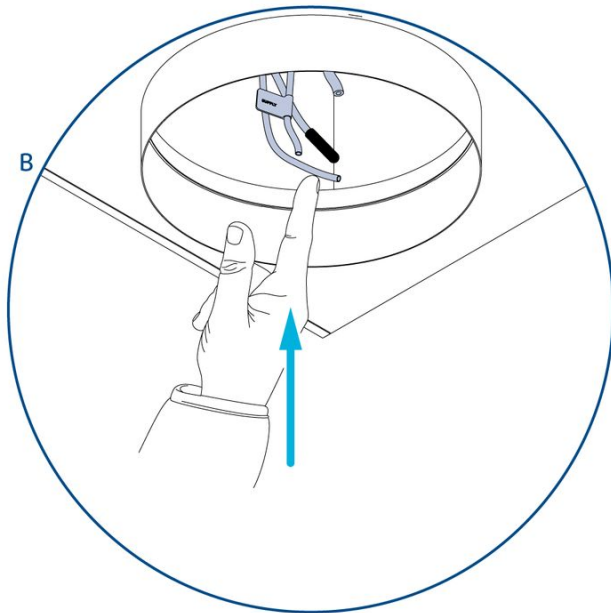
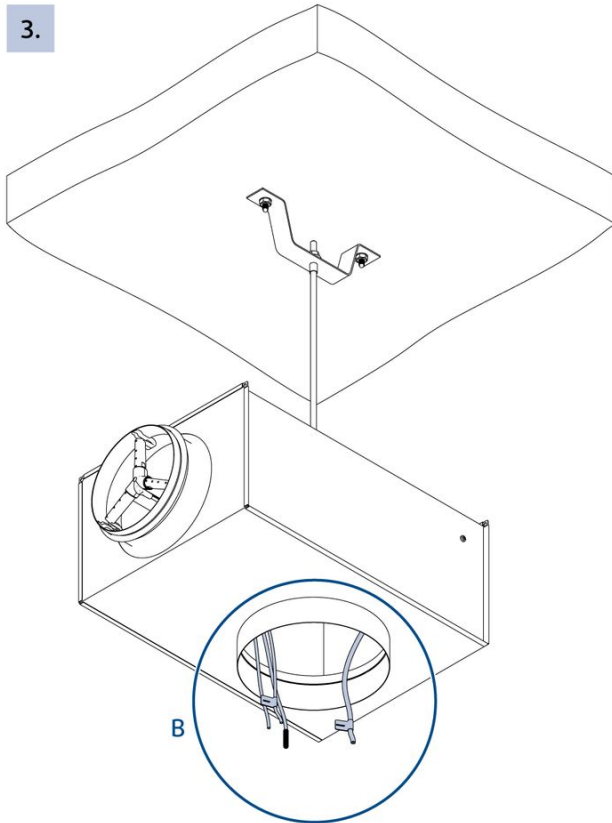

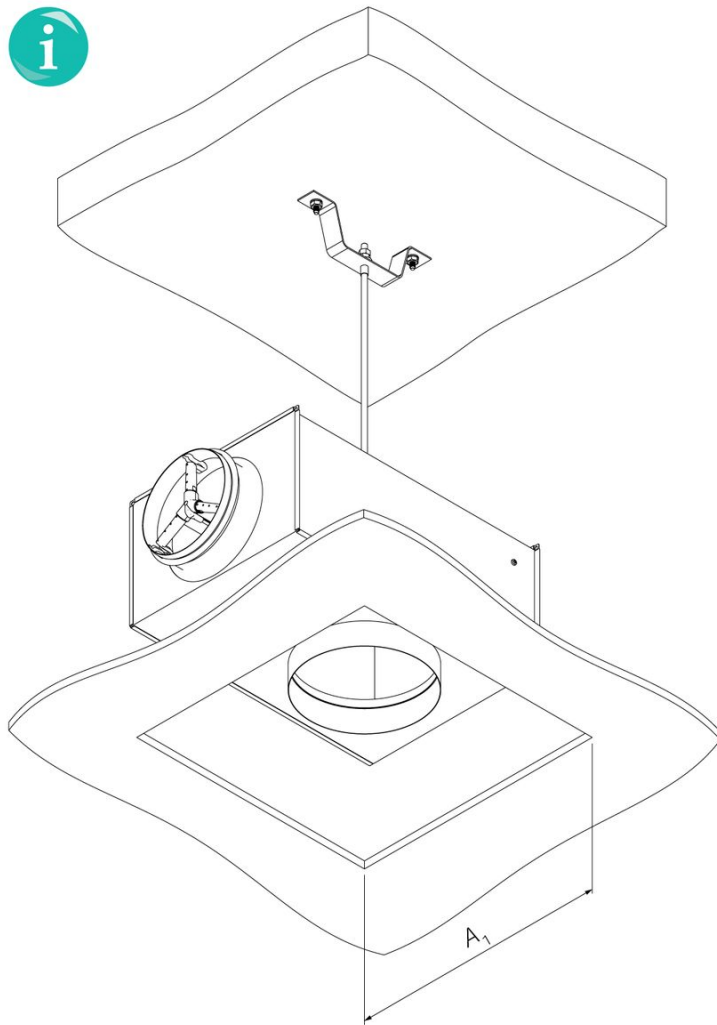

DN	A ₁
mm	
100	331
125	
160	
200	431
250	566
315	
400	

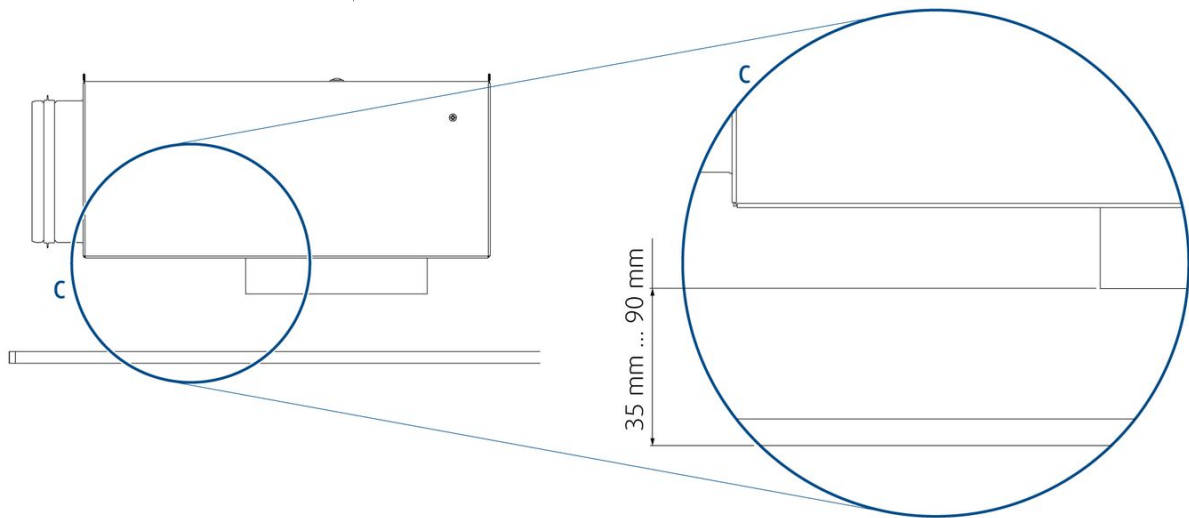

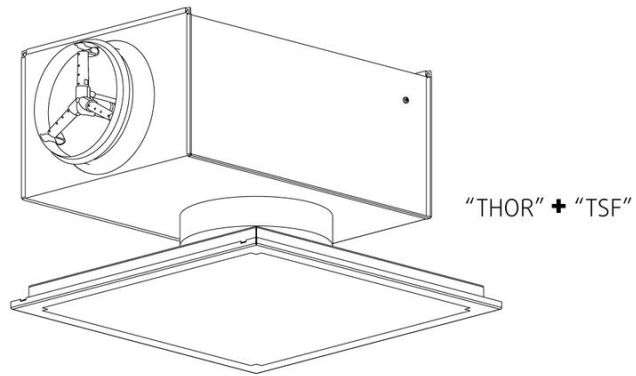

4.

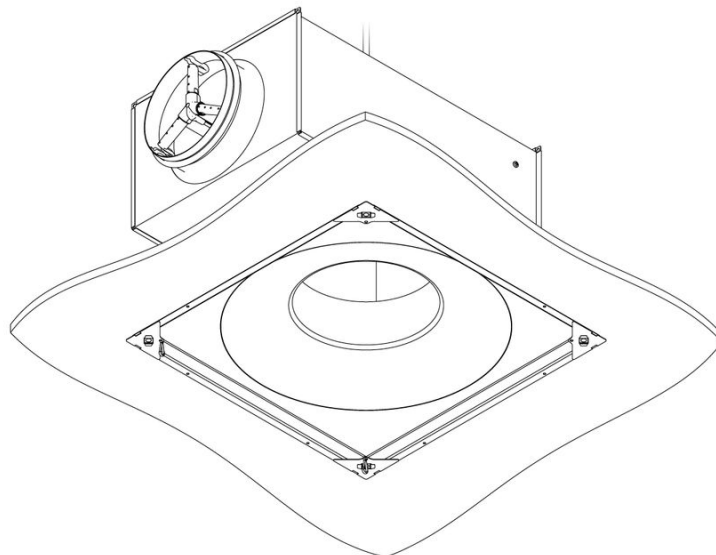
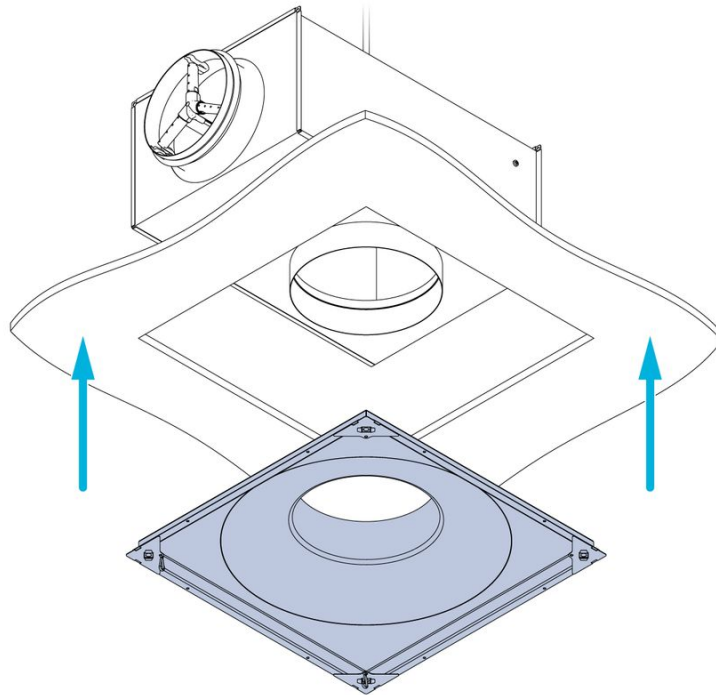

5.

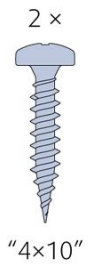
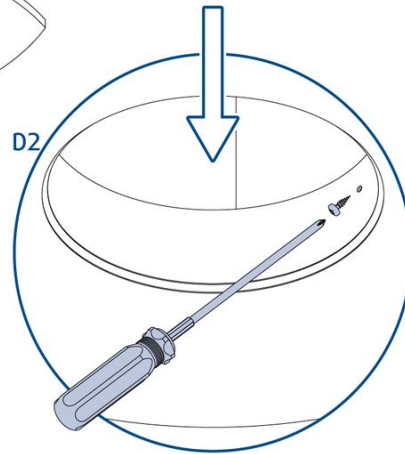
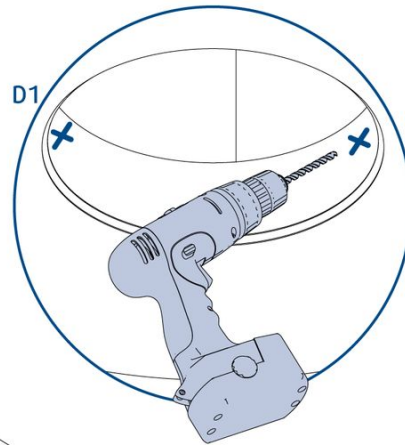
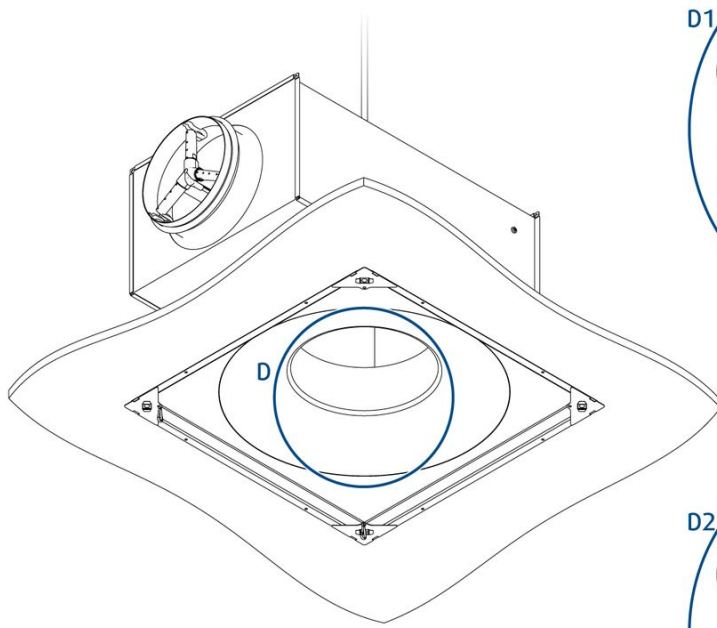

6.

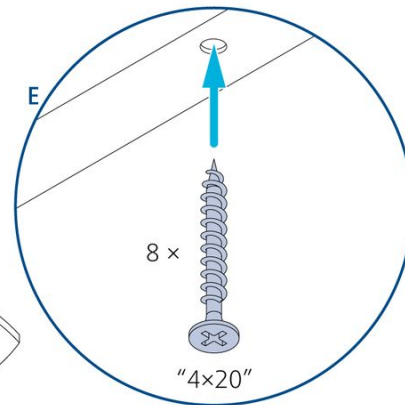
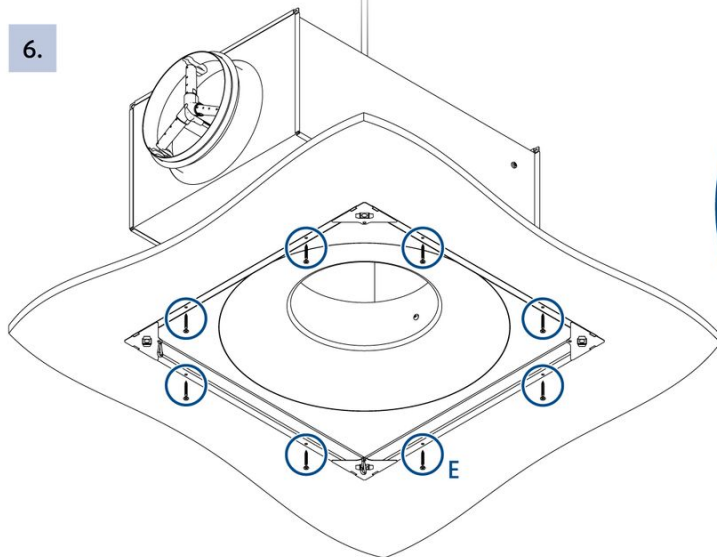

7.

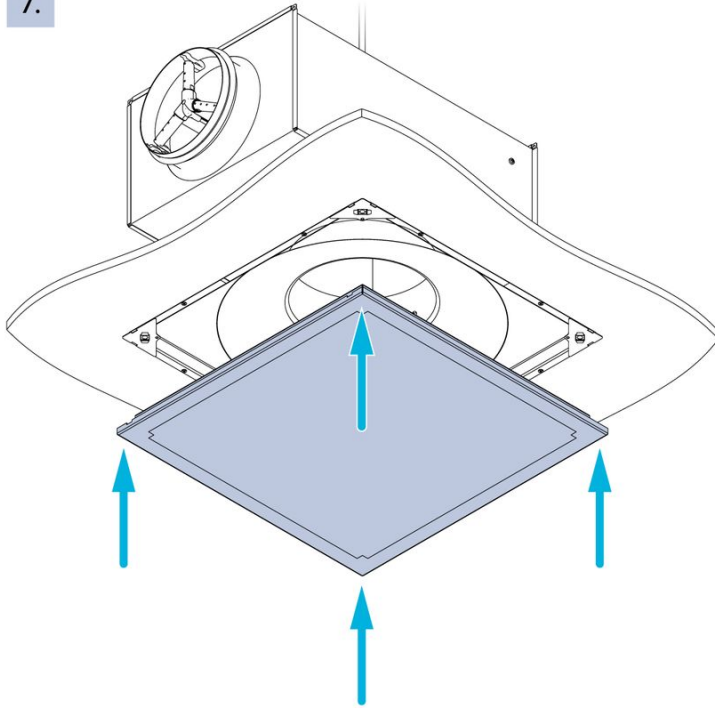

8.

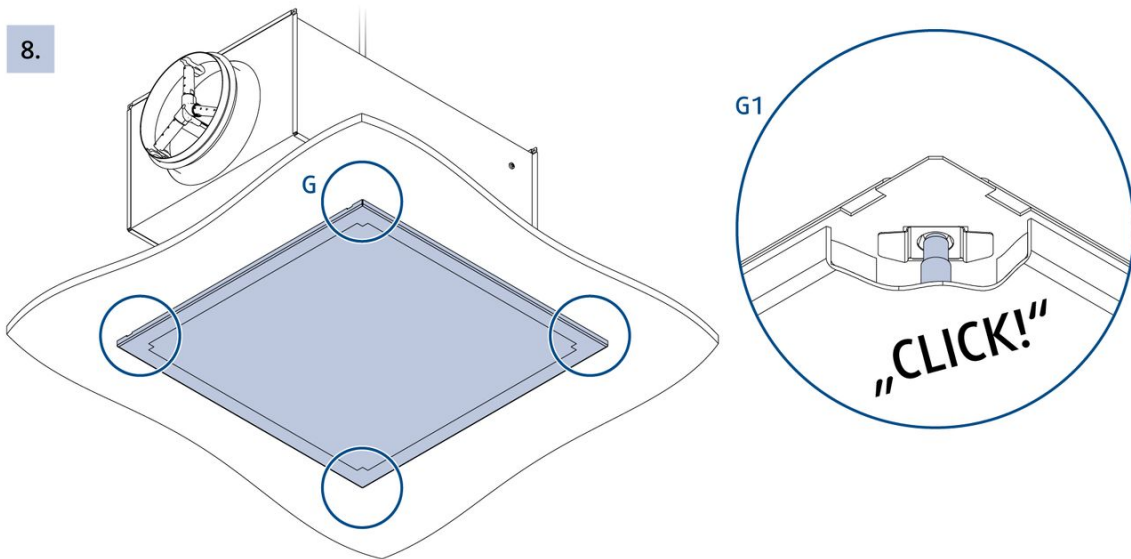

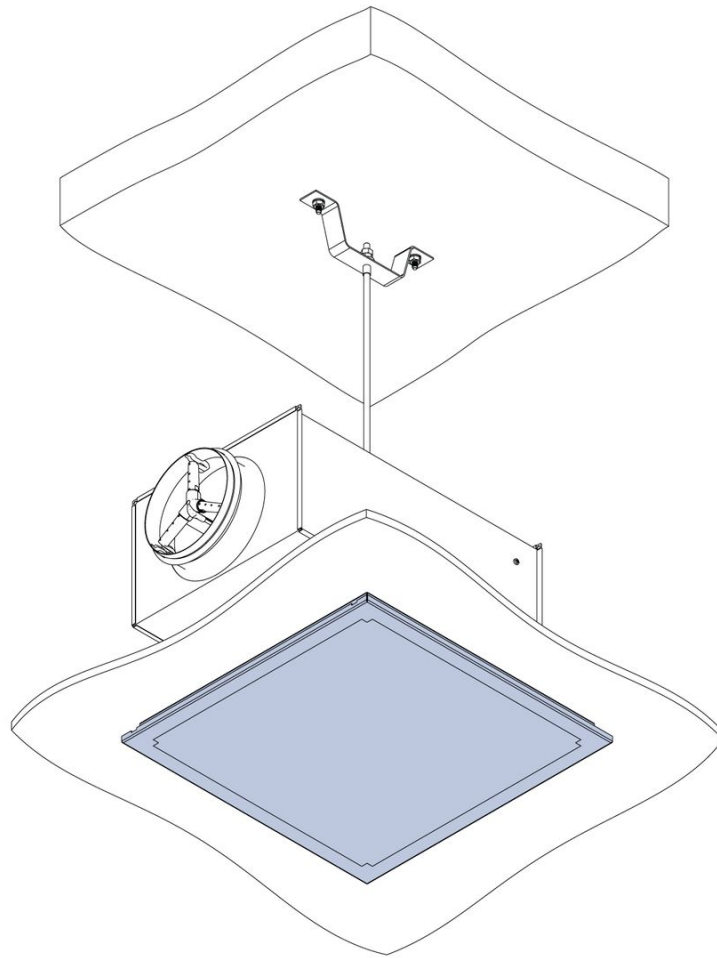

Transport, Storage and Operation

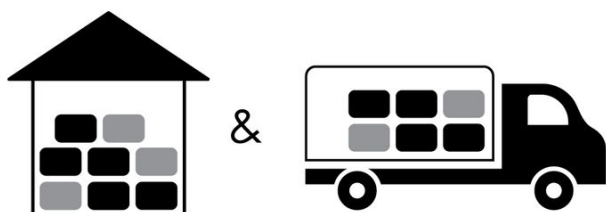

 °C -40°C ... +50°C

 % ≤ 95%



 °C -20°C ... +50°C

 % ≤ 95%

Supplement

Any deviations from the technical specifications contained herein and the terms should be discussed with the manufacturer. We reserve the right to make any changes to the product without prior notice, provided that these changes do not affect the quality of the product and the required parameters.

Current information on all products is available on design.systemair.com.

