

TSO  
Supply Diffuser  
Handbook

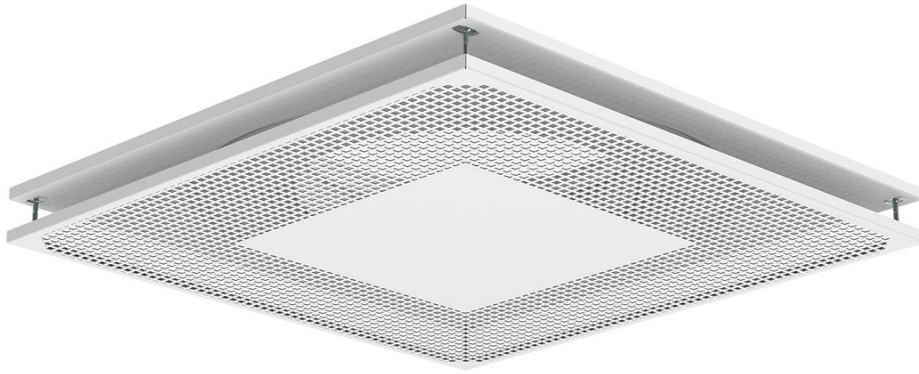

# Table of Contents

Description . . . . .	.3
Dimensions & Weights . . . . .	.5
Ordering Codes . . . . .	.6
Accessories . . . . .	.7
Technical Parameters . . . . .	.11
Installation . . . . .	.18
Transport, Storage and Operation . . . . .	.27
Supplement . . . . .	.28



## Description

TSO is a square supply and extract diffuser, designed for ceiling assembly. It has a perforated front plate and a connection sleeve fitted with a rubber seal, tested for airtightness. The TSO has high induction which allows a maximum air temperature difference of  $dT \pm 10$  K. The distribution unit is adjustable. The product is intended for use as air supply diffuser in offices, schools, hospitals etc.

### List of Accessories:

- THOR: Plenum Box
- SSO: Shielding Plate

## Design

The TSO is manufactured from steel with a white powder-coated finish and is available in 7 sizes. It consists of backing box and a perforated diffuser plate. The backing box has a connection sleeve fitted with a rubber gasket. The diffuser plate is removable to easy access to the duct.

### Product Parts

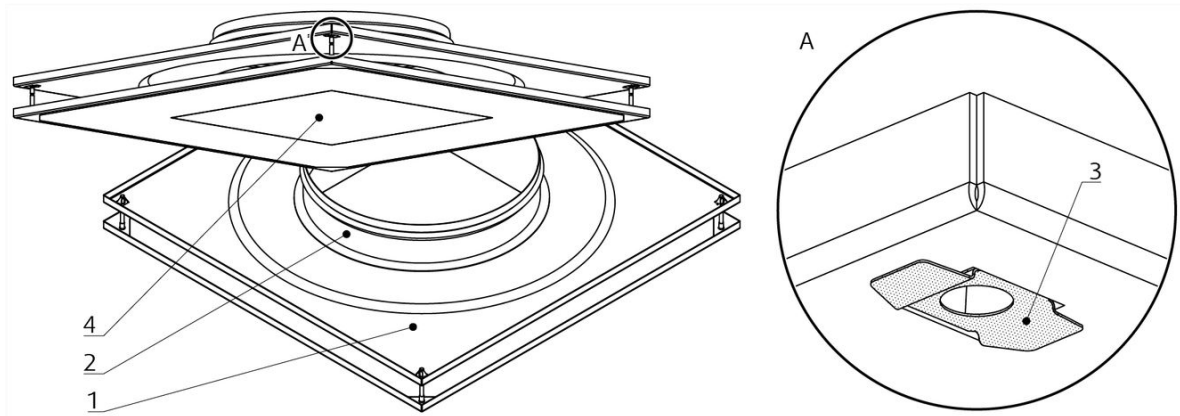

### Legend

- 1 Backing box
- 2 Connection with rubber gasket
- 3 Spring clips for diffuser plate fixing (inside the backing box)
- 4 Diffuser plate

# Dimensions & Weights

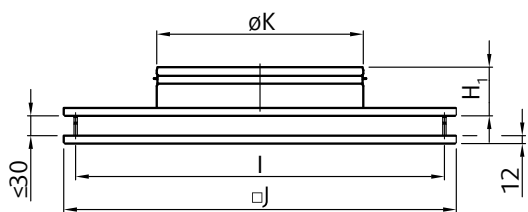

DN	$\varnothing K$	$J$	$I$	$H_1$	$m$
	mm				kg
100	99	300	264	67	1,7
125	124	300	264	67	2,6
160	159	300	264	67	5,3
200	199	400	364	67	2,7
250	249	595	559	75	5,8
315	314	595	559	75	5,6
400	399	595	559	95	5,4

# Ordering Codes

## Size - inlet ø (mm)

100

125

160

200

250

315

400

## Surface finish/material

**SW** Signal white (RAL9003, gloss 30%)

**RALxxxx** Other colour powder coating

## Example of the Ordering Code

**TSO-250-SW**

Diffuser of connection size 250 mm, signal white RAL9003

Notes: If no surface finish is stated in ordering code, the product will be delivered in signal white RAL9003.

# Accessories

## THOR

### Plenum Box



### Description

The THOR plenum box is used together with air diffusers for pressure reduction, airflow balancing and sound attenuation as well as for measuring and adjusting the air flow. The plenum box can be used for air inlet and extract.

### Design

THOR plenum boxes are manufactured from hot-dip galvanized sheet steel with inlet connection sleeve fitted with a rubber seal tested for air-tightness. The inlet is equipped by the ZEUS damper with impulse tubes for measuring differential pressure for flow volume calculation, using a portable measuring device. It can be adjusted manually using a cable gearing.

## Dimensions

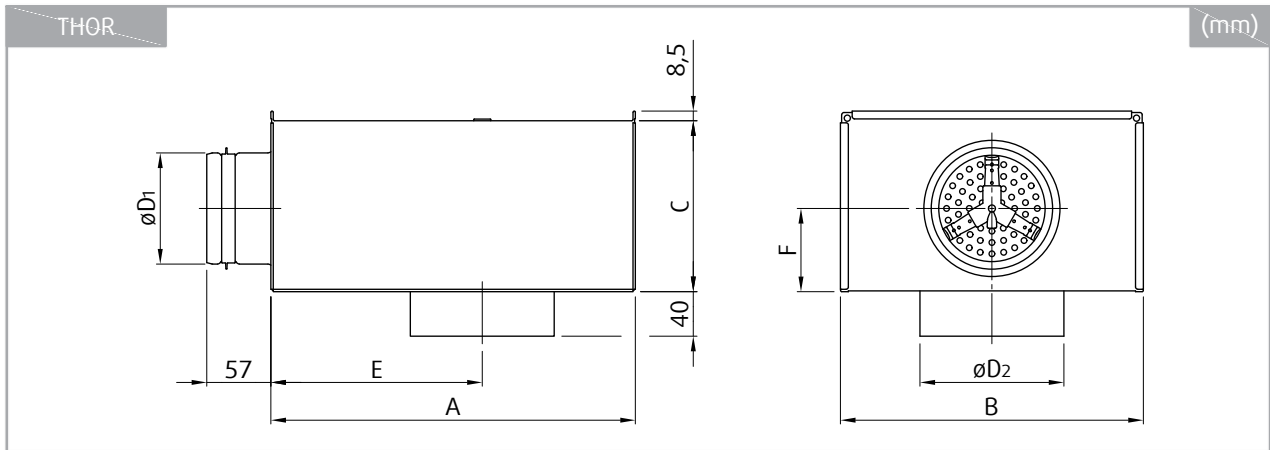

THOR	A	B	C	$\varnothing D_1$	$\varnothing D_2$	E	F	m
	mm							kg
100-125	320	267	150	98	126	185	75	2,5
125-160	360	267	160	123	161	210	80	2,9
160-200	450	317	195	158	201	280	98	4,0
200-250	500	367	250	198	251	305	125	5,4
250-315	565	467	300	248	316	330	150	7,3
315-400	620	567	400	313	401	360	200	10,1

## Ordering Codes

## Nominal size: Inlet-Outlet

80-100

100-125

125-160

160-200

200-250

250-315

315-400

## Example of the Ordering Code

THOR-100-125

Plenum box THOR with 100 mm circular inlet and 125 mm circular outlet (nominal dimensions).



## SSO

### Shielding Plate



### Description

SSO is a shielding accessory, that can alter the air distribution pattern to 1-, 2- or 3-way distribution (three SSO plates are used to provide one-way distribution, two SSO plates are fitted to provide two-way distribution, and so on). SSO is fitted with the tape provided. It is manufactured from steel with a white powder-coated finish.

SSO can be cut to the desired length to provide shielding that is shorter than an entire side.

## Dimensions

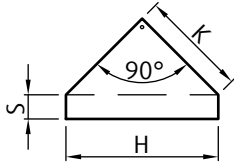

DN	H	K	S	m
	mm			kg
100	255	180	40	0,10
125	255	180	40	0,10
160	255	180	40	0,10
200	355	252	40	0,20
250	550	392	40	0,50
315	550	392	40	0,50
400	550	392	40	0,50

## Ordering Codes

For nominal sizes DN:

100-125-160

200

250-315-400

## Surface finish/material

**SW** Signal white (RAL9003, gloss 30%)

**RALxxxx** Other colour powder coating

## Example of the Ordering Code

SSO-100-125-160-SW

Directional shielding for the diffuser TSO of nominal sizes 100, 125 or 160 with RAL9003 signal white powder coating.

# Technical Parameters

## Legend

$p_s$  (Pa) Pressure drop

$q_v$  (m<sup>3</sup>/h or l/s) Air flow volume

$L_{WA}$  (dB(A)) A-weighted total radiated sound power level

$L_{pA}$  (dB(A)) A-weighted total sound pressure level expressed for 10 m<sup>2</sup> room absorption area

$L_W$  (dB) Non weighted total sound power level

$L_{0,2}$  (m) Air throw length with terminal velocity 0,2 m/s

$L_x$  (m) Air throw length calculated for specific terminal velocity

$x$  (m/s) Terminal velocity in range of 0,1 m/s ... 1 m/s

**20%, 40%, 60%, 80%, 100%** The plenum box damper positions in pressure drop/noise diagrams are represented as percentage. 20% is fully closed damper. 100% is fully open damper.

## Calculation of Air Throw for Different Terminal Velocities

$$L_x = L_{0,2} \cdot 0,2/x$$

Pressure drop and radiated sound power level dependent on air flow volume

Throw length with terminal velocity 0,2 m/s dependent on air flow volume

### TSO-100-SW

Pressure drop & A-weighted sound power level in dB(A)

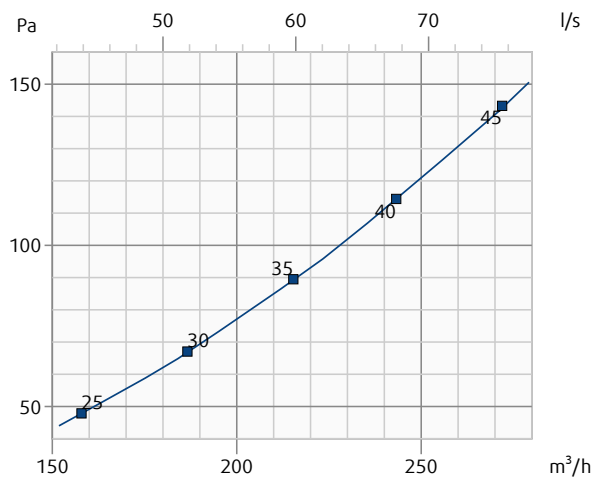

### TSO-100-SW

Throw length (terminal velocity 0.2 m/s)

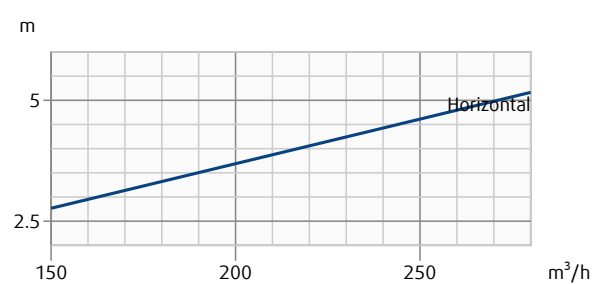

Pressure drop and radiated sound power level dependent on air flow volume

Throw length with terminal velocity 0,2 m/s dependent on air flow volume

**TSO-125-SW**

Pressure drop & A-weighted sound power level in dB(A)

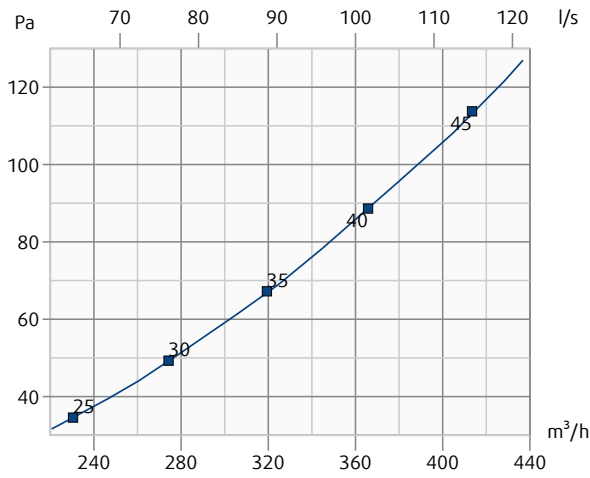

**TSO-125-SW + THOR-100-125**

Pressure drop & A-weighted sound power level in dB(A)

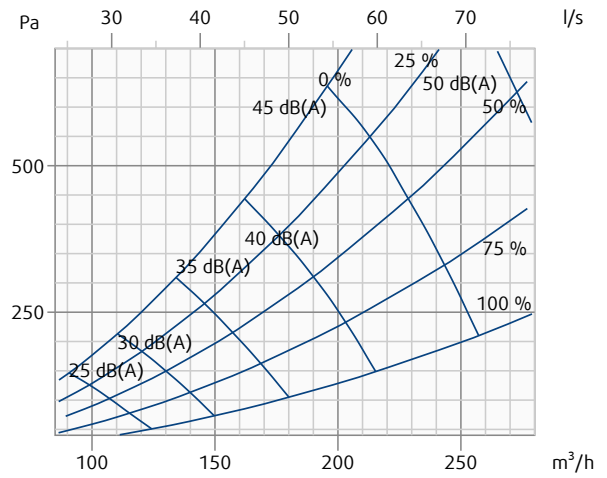

**TSO-125-SW**

Throw length (terminal velocity 0.2 m/s)

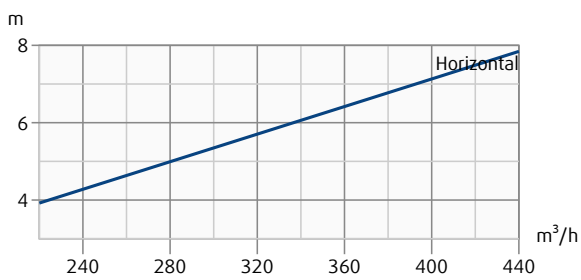

**TSO-125-SW + THOR-100-125**

Throw length (terminal velocity 0.2 m/s)

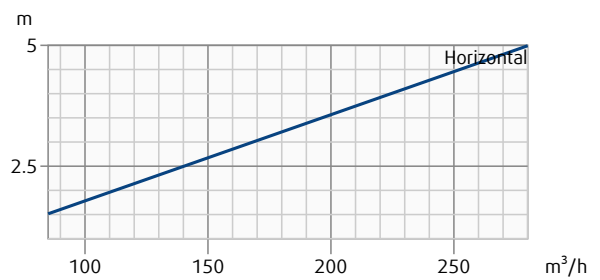

Pressure drop and radiated sound power level dependent on air flow volume

Throw length with terminal velocity 0,2 m/s dependent on air flow volume

**TSO-160-SW**

Pressure drop & A-weighted sound power level in dB(A)

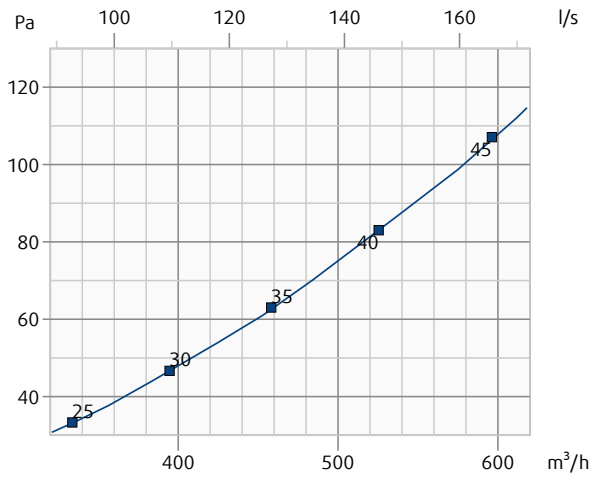

**TSO-160-SW + THOR-125-160**

Pressure drop & A-weighted sound power level in dB(A)

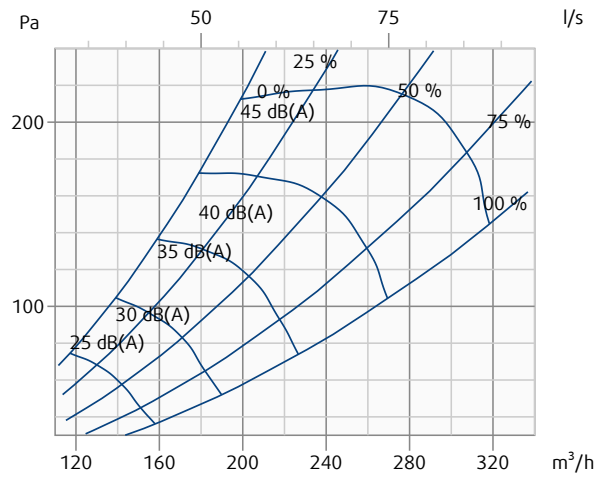

**TSO-160-SW**

Throw length (terminal velocity 0.2 m/s)

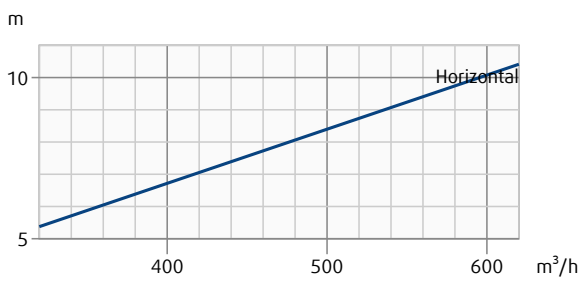

**TSO-160-SW + THOR-125-160**

Throw length (terminal velocity 0.2 m/s)

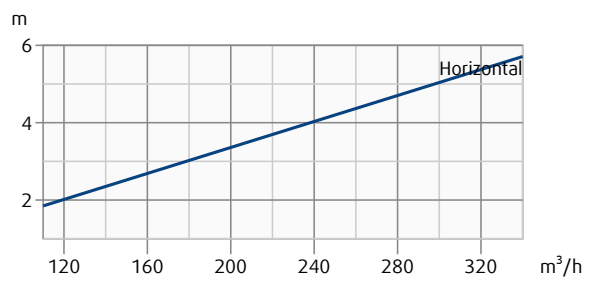

Pressure drop and radiated sound power level dependent on air flow volume

Throw length with terminal velocity 0,2 m/s dependent on air flow volume

**TSO-200-SW**

Pressure drop & A-weighted sound power level in dB(A)

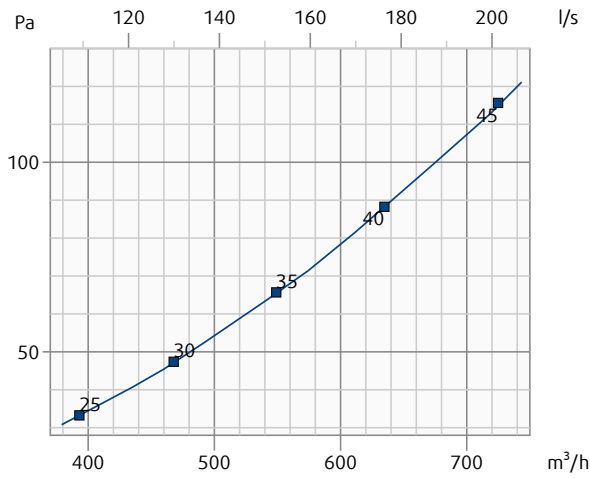

**TSO-200-SW + THOR-160-200**

Pressure drop & A-weighted sound power level in dB(A)

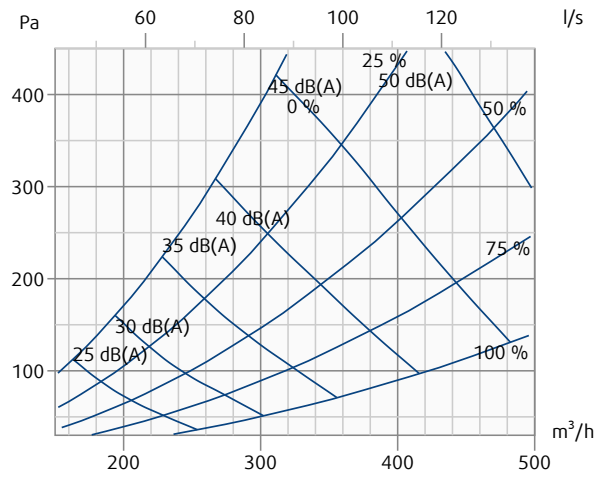

**TSO-200-SW**

Throw length (terminal velocity 0.2 m/s)

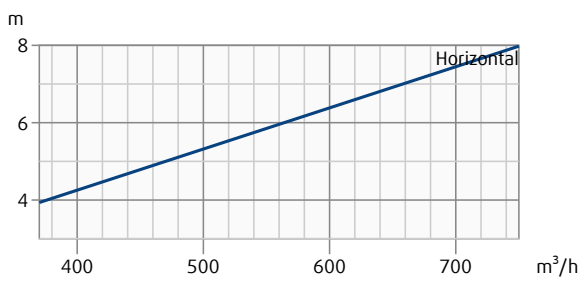

**TSO-200-SW + THOR-160-200**

Throw length (terminal velocity 0.2 m/s)

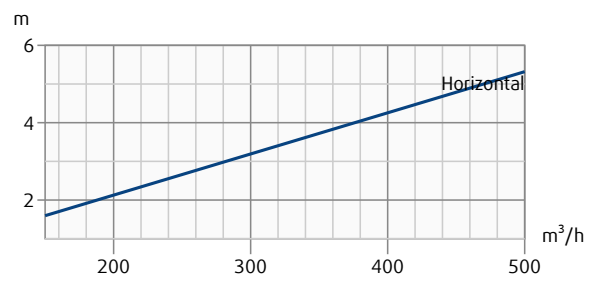

Pressure drop and radiated sound power level dependent on air flow volume

Throw length with terminal velocity 0,2 m/s dependent on air flow volume

**TSO-250-SW**

Pressure drop & A-weighted sound power level in dB(A)

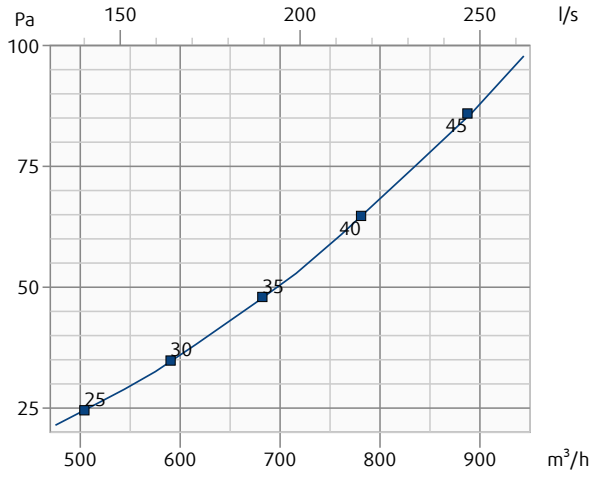

**TSO-250-SW + THOR-200-250**

Pressure drop & A-weighted sound power level in dB(A)

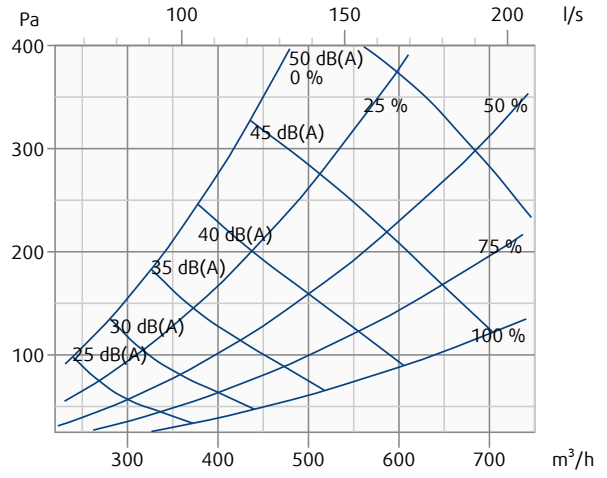

**TSO-250-SW**

Throw length (terminal velocity 0.2 m/s)

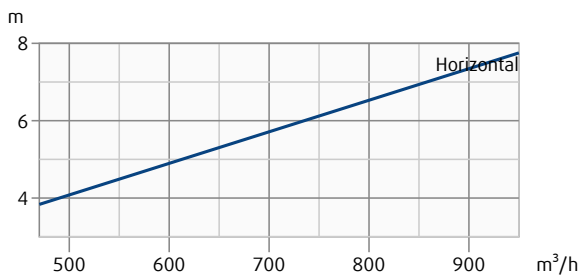

**TSO-250-SW + THOR-200-250**

Throw length (terminal velocity 0.2 m/s)

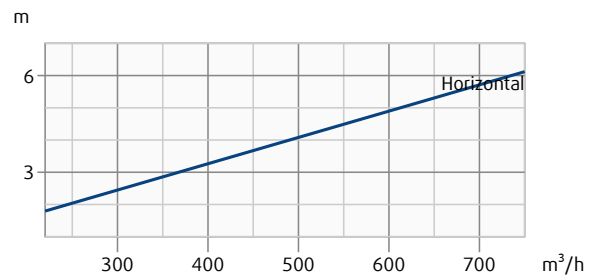

Pressure drop and radiated sound power level dependent on air flow volume

Throw length with terminal velocity 0,2 m/s dependent on air flow volume

**TSO-315-SW**

Pressure drop & A-weighted sound power level in dB(A)

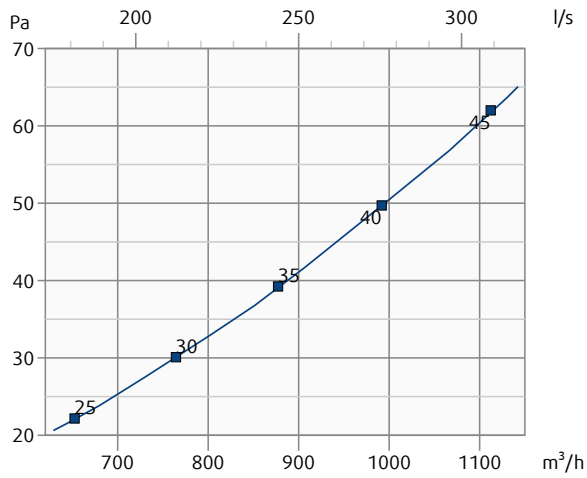

**TSO-315-SW + THOR-250-315**

Pressure drop & A-weighted sound power level in dB(A)

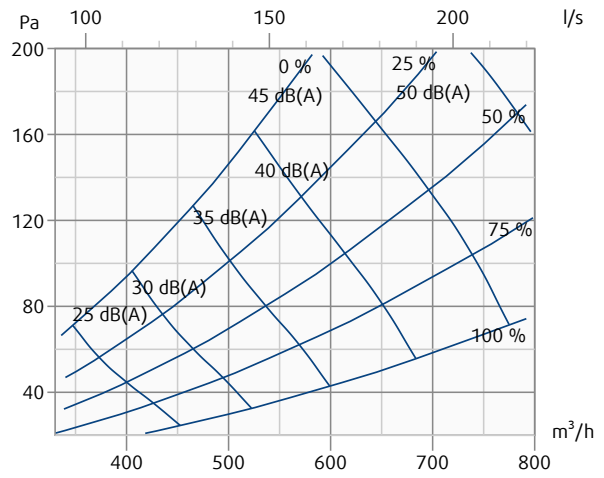

**TSO-315-SW**

Throw length (terminal velocity 0.2 m/s)

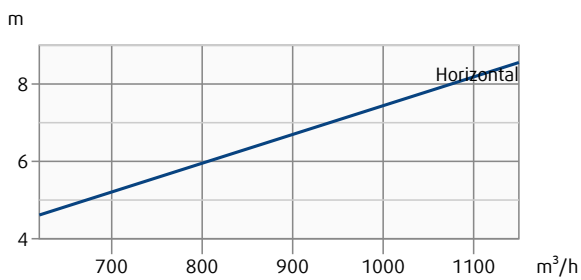

**TSO-315-SW + THOR-250-315**

Throw length (terminal velocity 0.2 m/s)

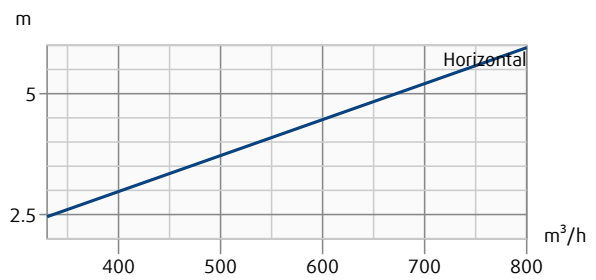



Pressure drop and radiated sound power level dependent on air flow volume

Throw length with terminal velocity 0,2 m/s dependent on air flow volume

**TSO-400-SW**

Pressure drop & A-weighted sound power level in dB(A)

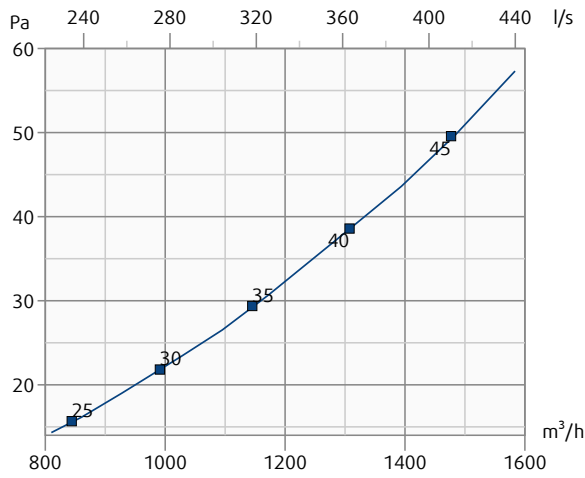

**TSO-400-SW + THOR-315-400**

Pressure drop & A-weighted sound power level in dB(A)

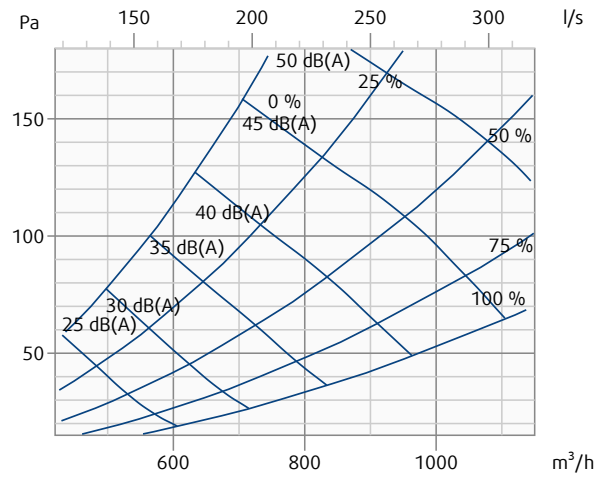

**TSO-400-SW**

Throw length (terminal velocity 0.2 m/s)

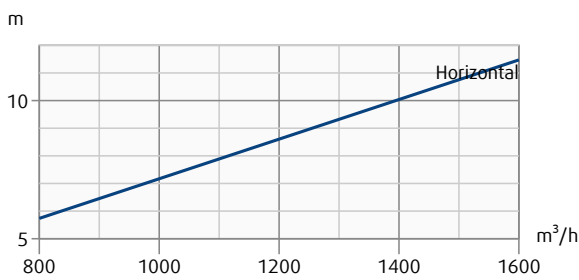

**TSO-400-SW + THOR-315-400**

Throw length (terminal velocity 0.2 m/s)

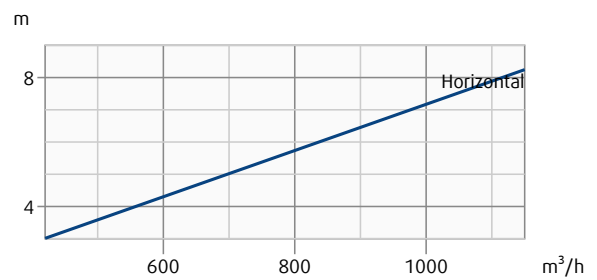

# Installation

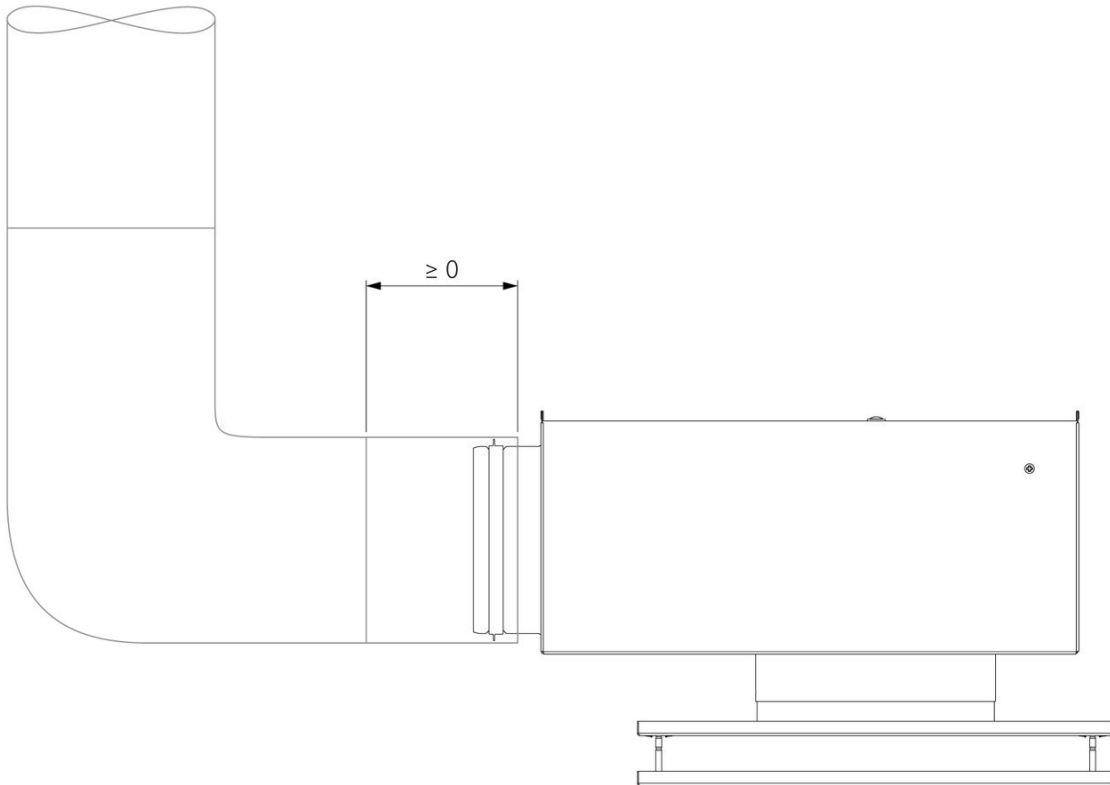
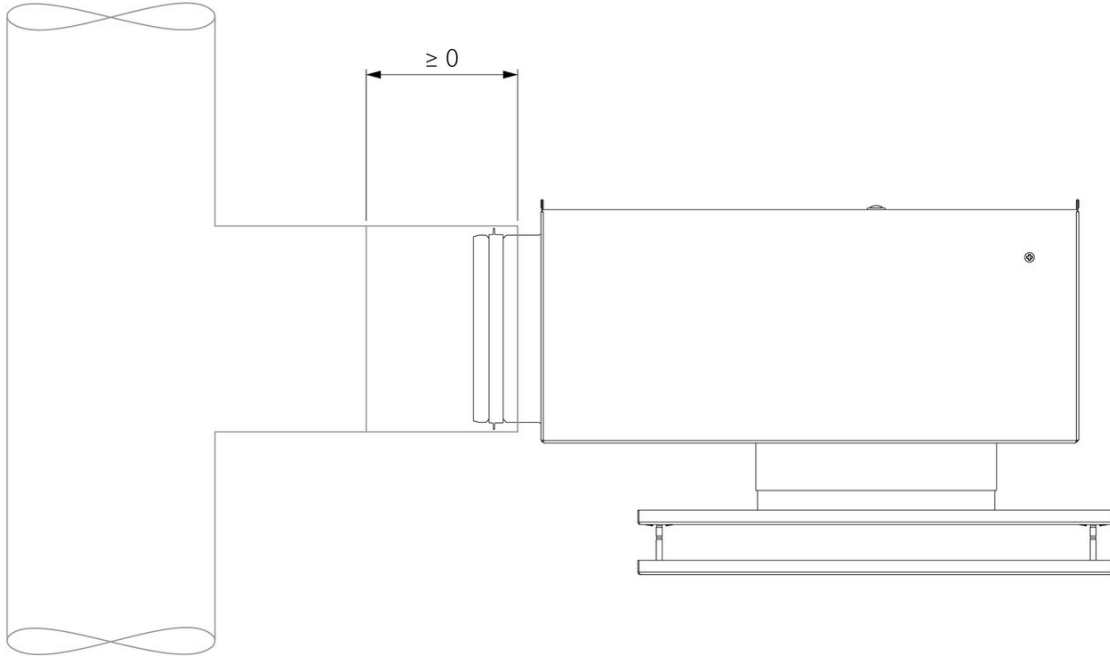

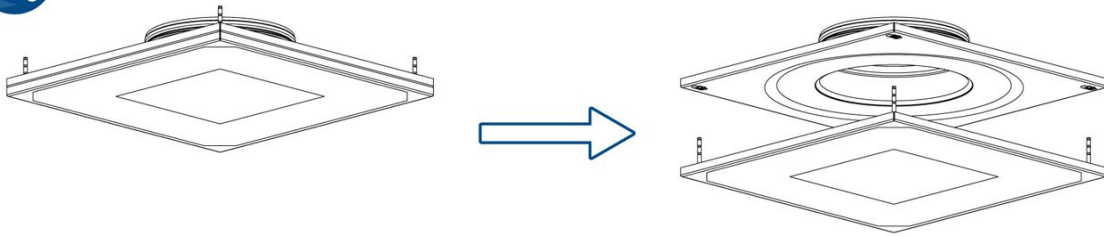

1.

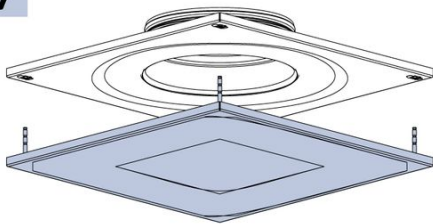
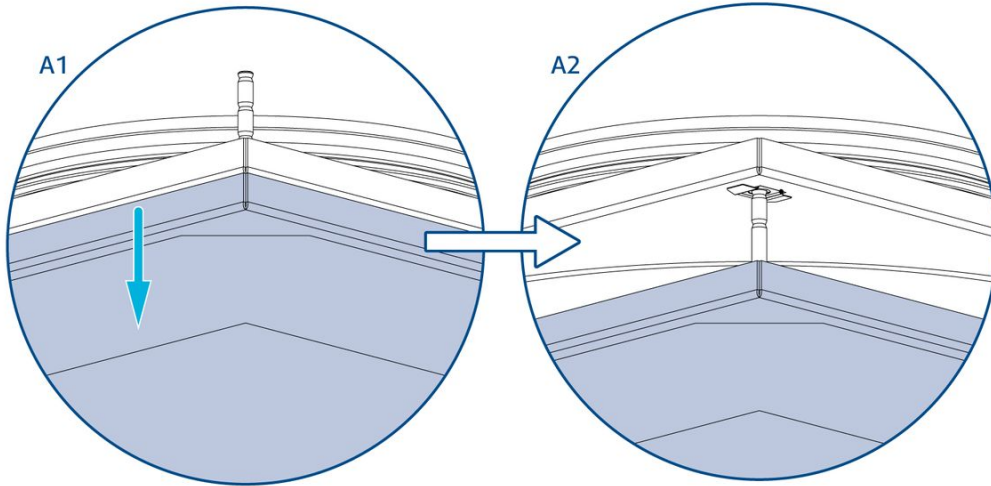
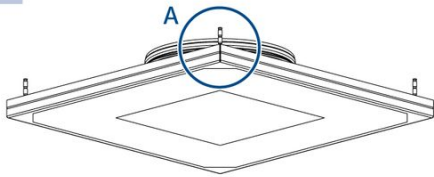

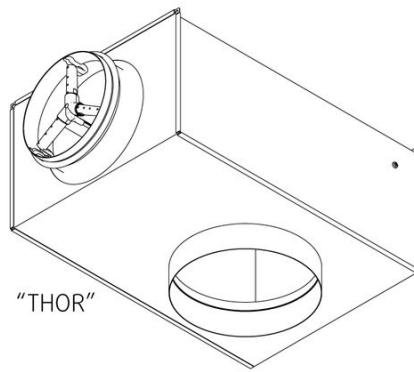

2.

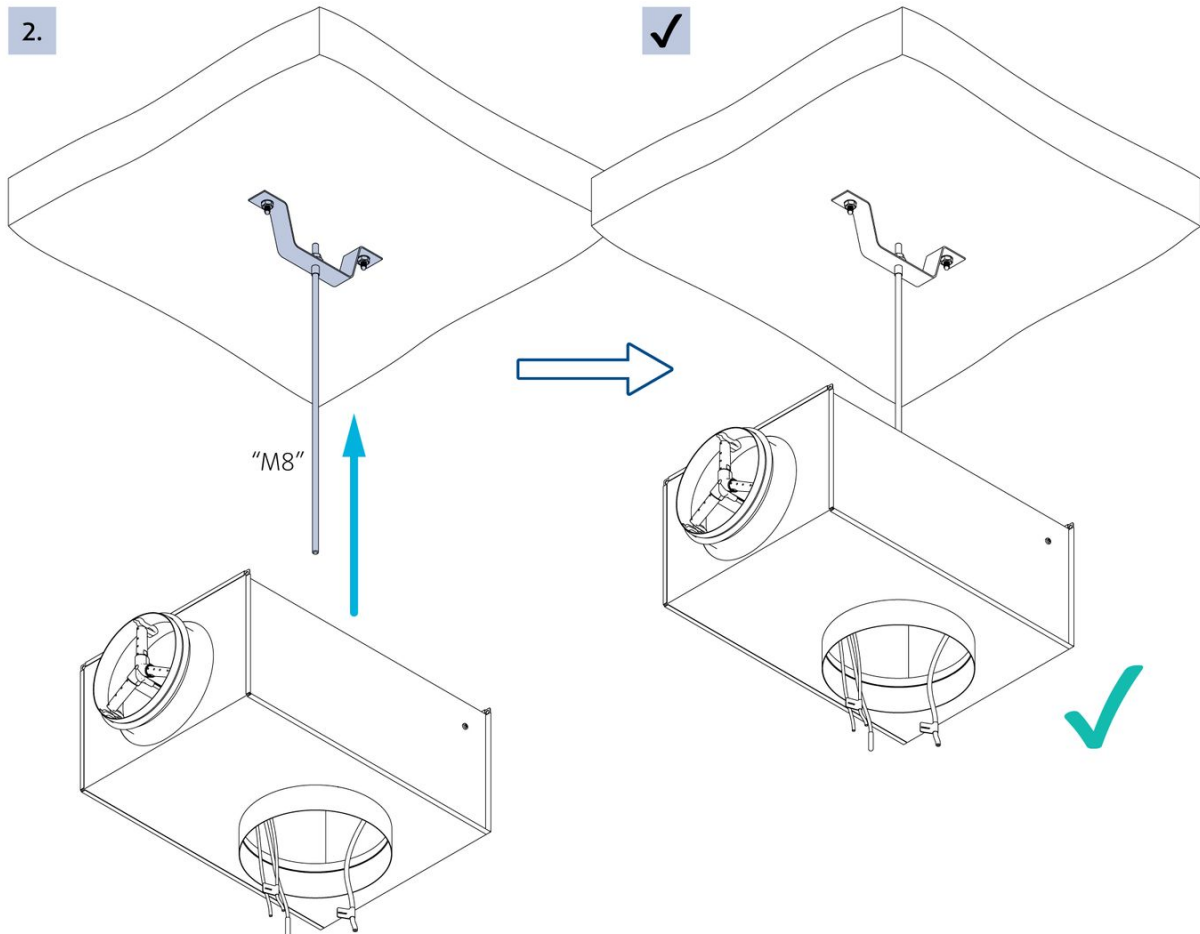

3.

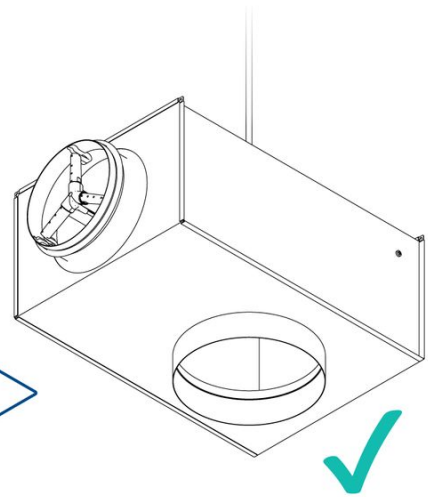
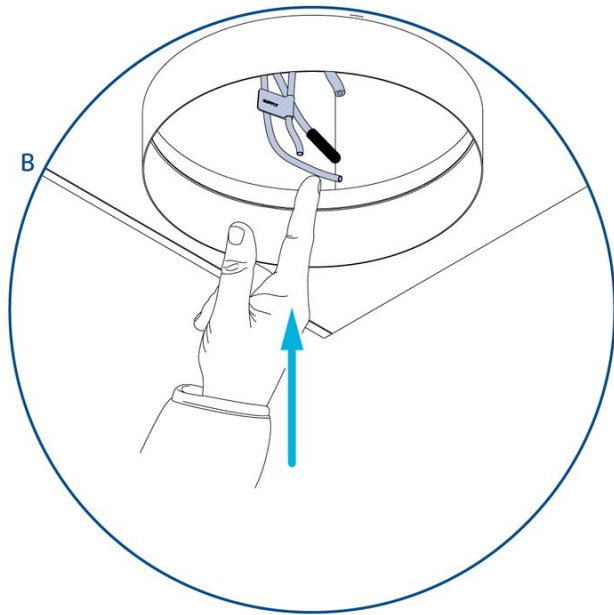
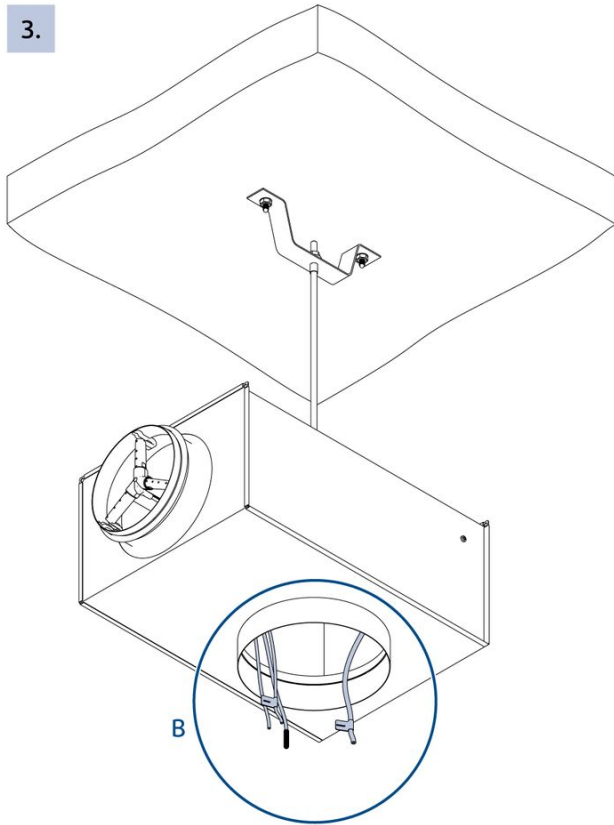

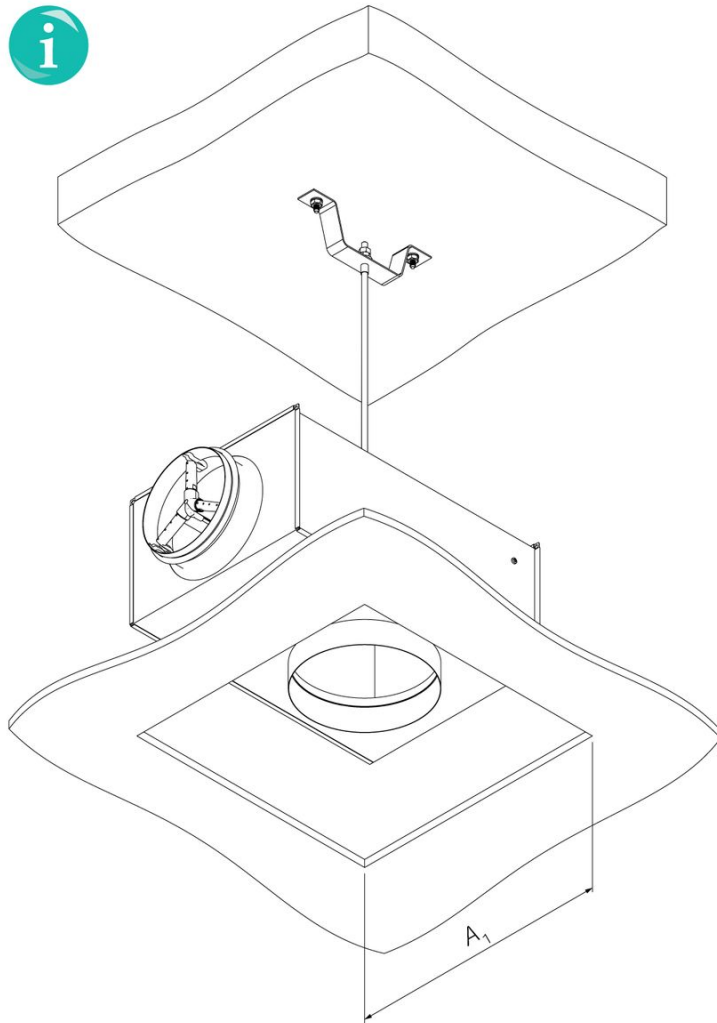

DN	A <sub>1</sub>
mm	
100	305
125	
160	
200	405
250	600
315	
400	

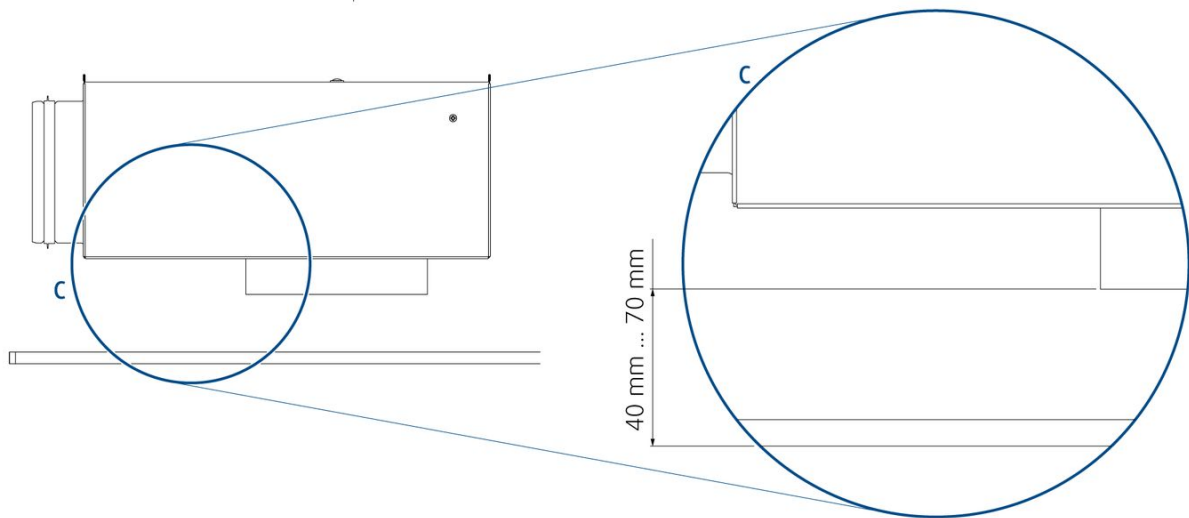

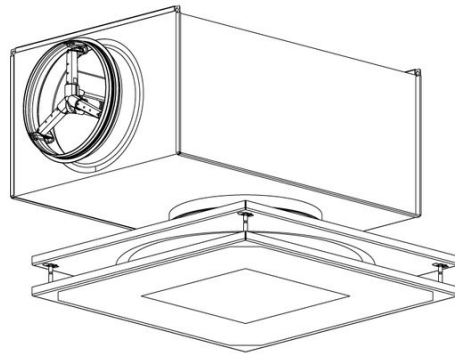

"THOR" + "TSO"

4.

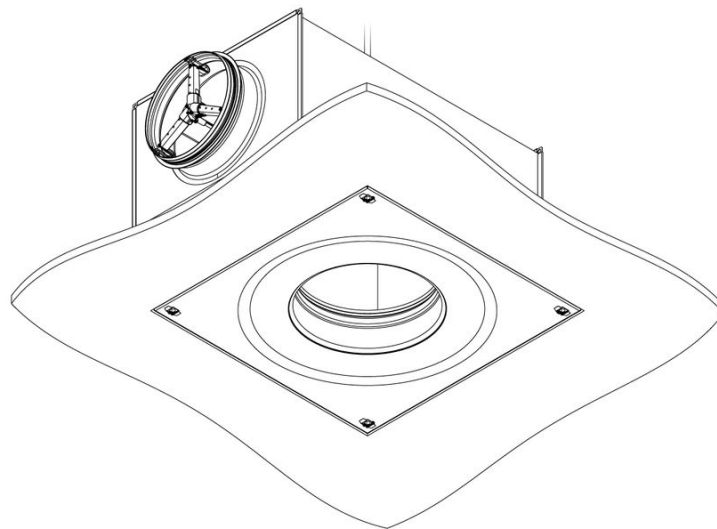
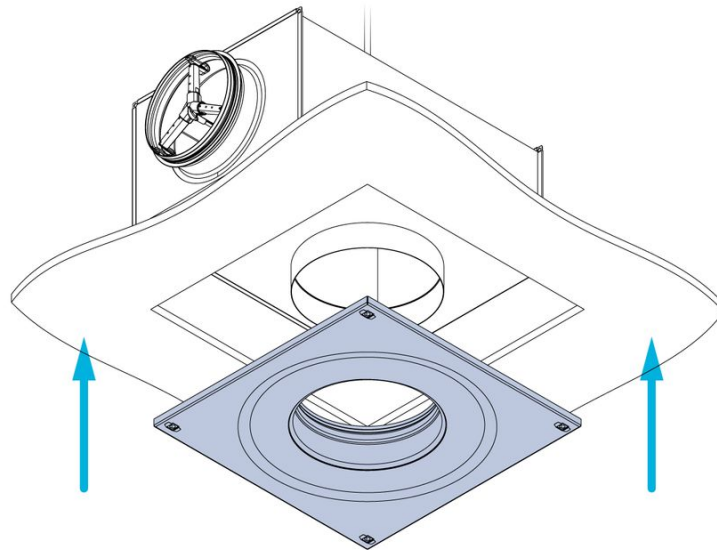

5.

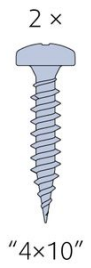
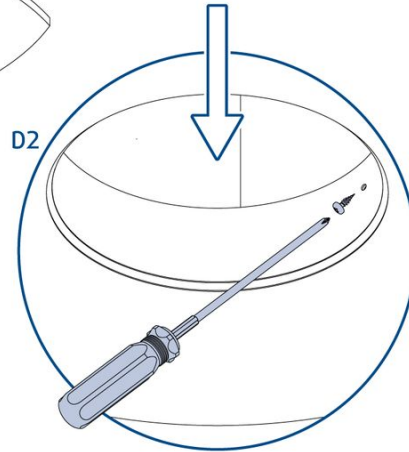
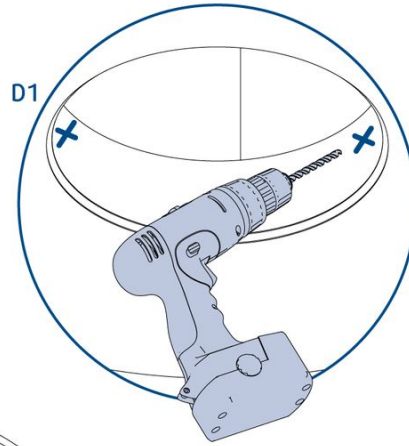
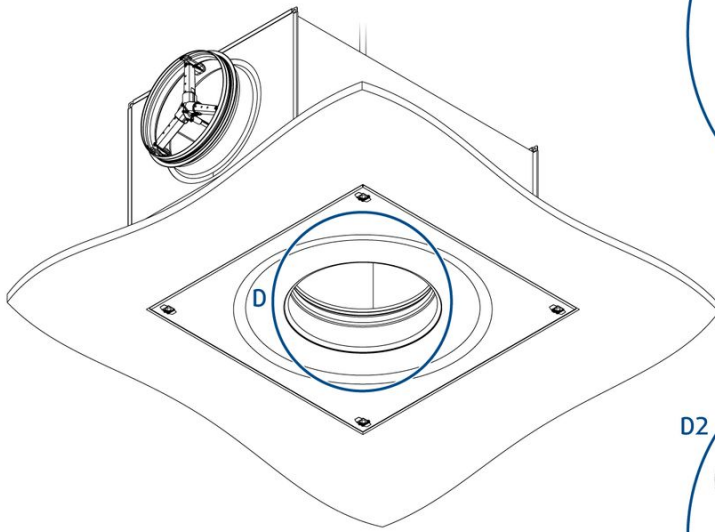

6.

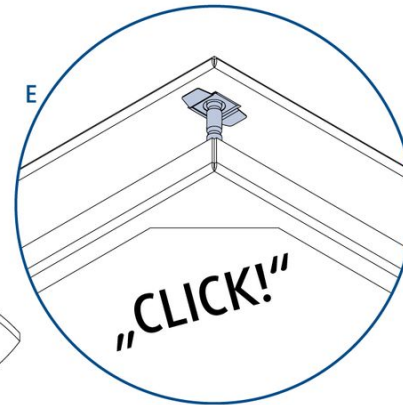
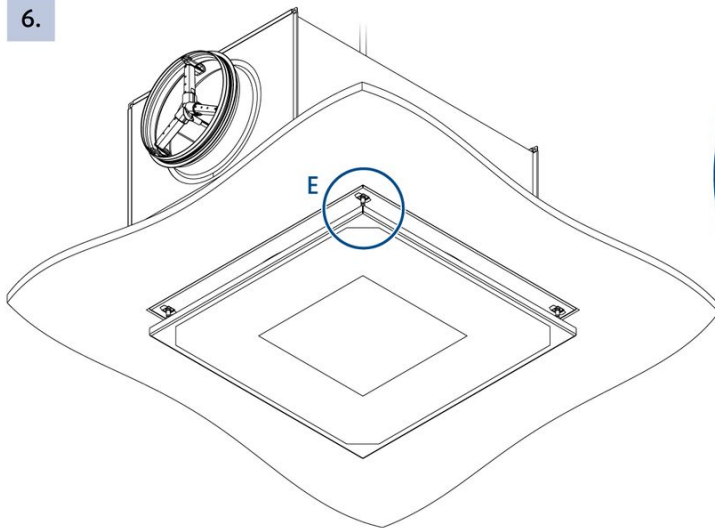





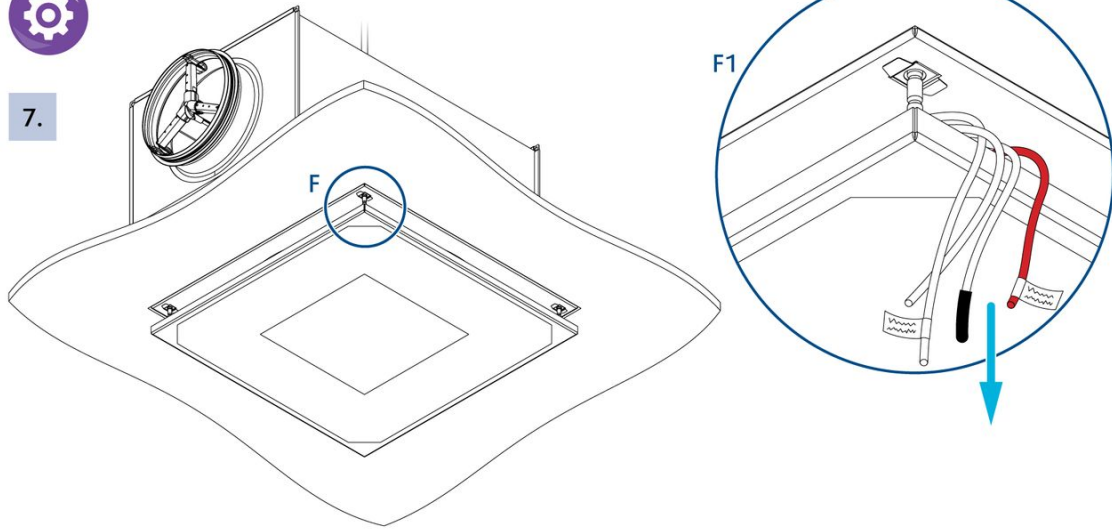

7.

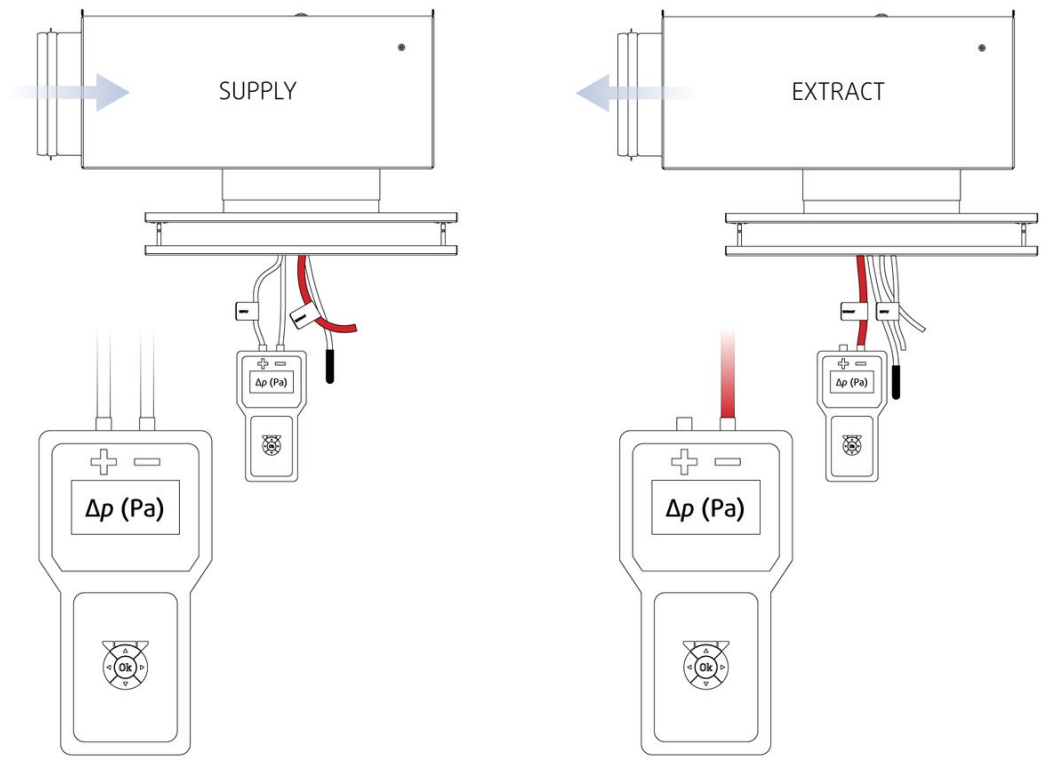

8.

$$q = k \sqrt{\Delta p \text{ (Pa)}}$$



SUPPLY 		k	
TSO	THOR	m³/h	l/s
100			
125	100-125	19,1	5,3
160	125-160	33,1	9,2
200	160-200	57,2	15,9
250	200-250	93,6	26,0
315	250-315	150,1	41,7
400	315-400	258,8	71,9

EXTRACT 		k	
TSO	THOR	m³/h	l/s
100			
125	100-125	58,8	16,3
160	125-160	85,3	23,7
200	160-200	92,5	25,7
250	200-250	118,8	33,0
315	250-315	146,8	40,8
400	315-400	202,8	56,3

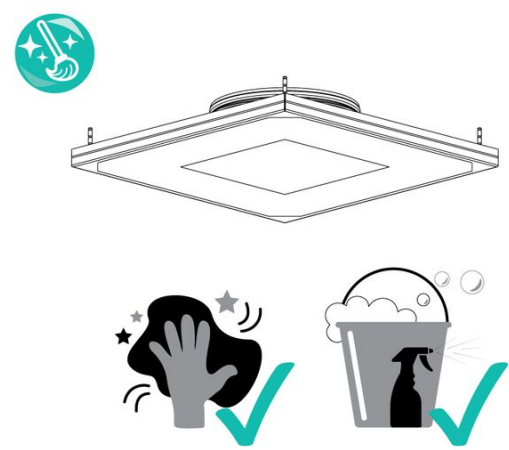
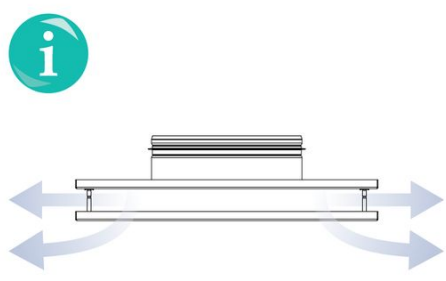
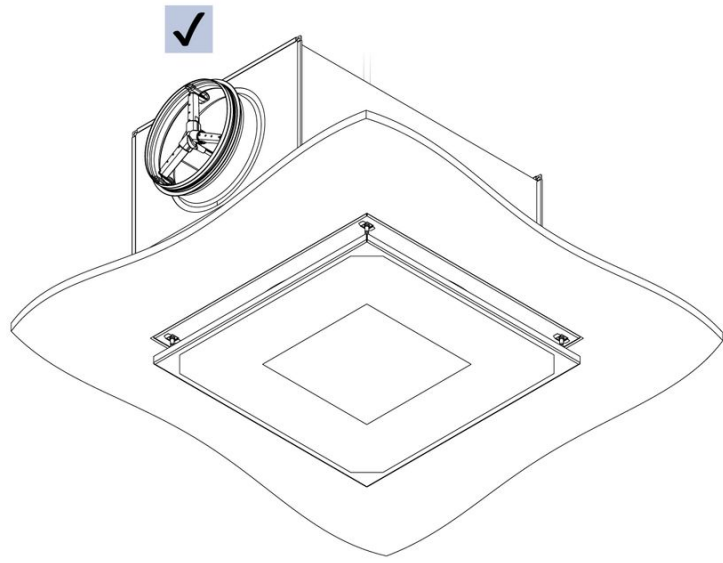
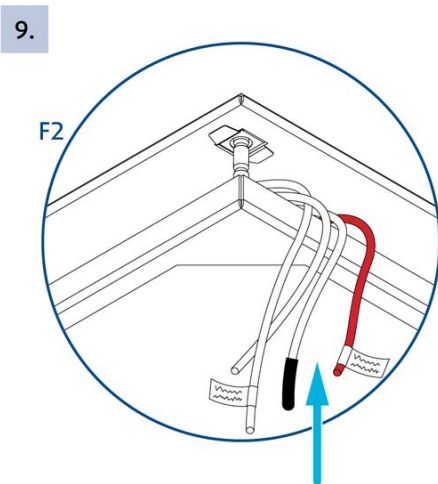

# Transport, Storage and Operation

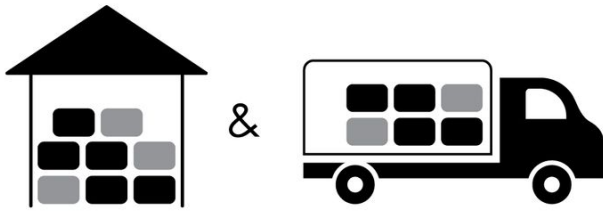

 °C -40°C ... +50°C

 % ≤ 95%



 °C -20°C ... +50°C

 % ≤ 95%

# Supplement

Any deviations from the technical specifications contained herein and the terms should be discussed with the manufacturer. We reserve the right to make any changes to the product without prior notice, provided that these changes do not affect the quality of the product and the required parameters.

Current information on all products is available on [design.systemair.com](https://design.systemair.com).

