



Handbook

TST

Supply Diffuser



Table of Contents

Description	3
Dimensions & Weights	5
Ordering Codes	6
Accessories	7
Technical Parameters	10
Installation	16
Transport, Storage and Operation	23
Supplement	24

Description

TST is a diffuser. The product is intended for air supply. The product is installed into ceilings. The product can be connected directly to the end of a duct, or to the THOR plenum box. The two-part diffuser unit can be adjusted to provide the desired throw. The field of application is offices, shops, medical rooms, school classrooms, etc.

Highlights

- Simple and safe design
- Easy installation and handling
- Operable also without plenum box, connected directly to the duct
- Maintenance free

Accessory

- **THOR:** Plenum Box

Design

TST is manufactured from galvanized sheet metal. The product consists of a front panel and a backing panel with a duct connector. The front panel has fixing pins with multiple grooves. The pins are fitted into the snap springs in the backing panel. The product has a 360° discharge pattern from which up to 180° can be shielded by a foam deflector. The product is powder painted to RAL9003 (signal white) as standard. Other RAL colours are available upon request.

Product Parts

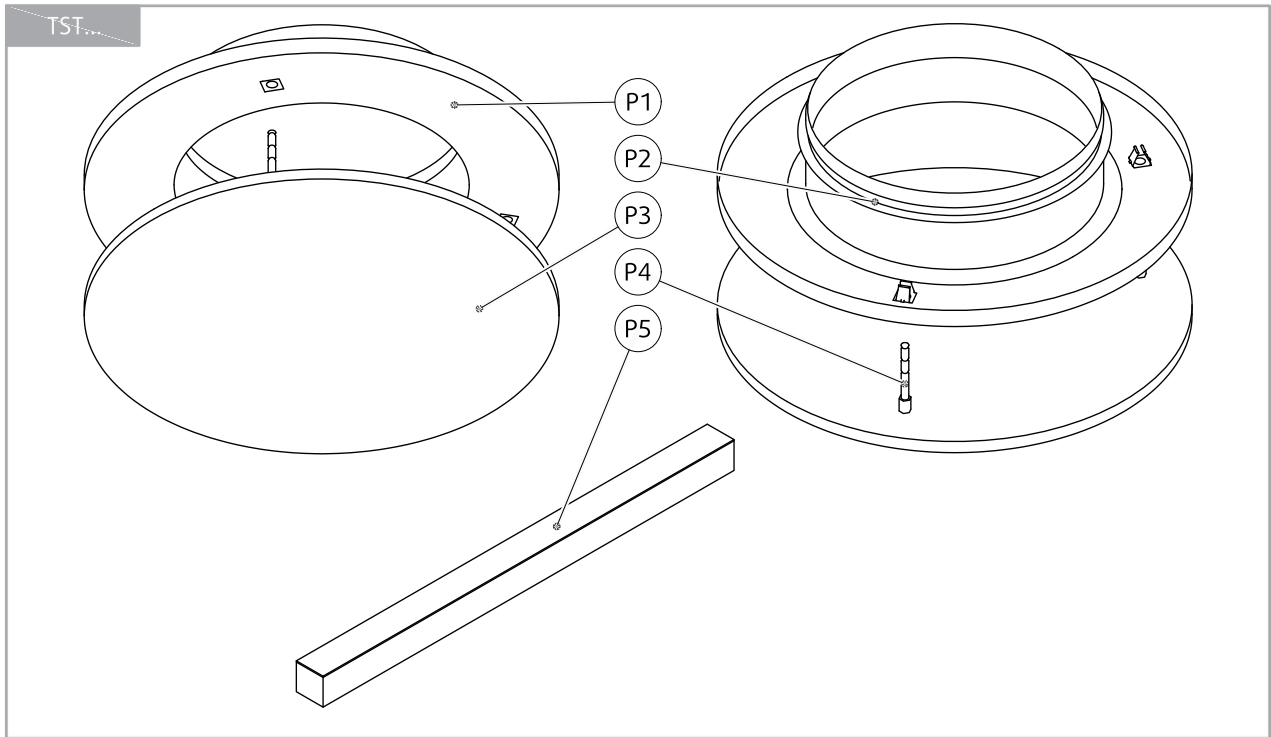

Legend:

- P1 - Backing panel
- P2 - Duct connector with a EPDM gasket
- P3 - Front panel
- P4 - Fixing pins
- P5 - Foam deflector

Dimensions & Weights

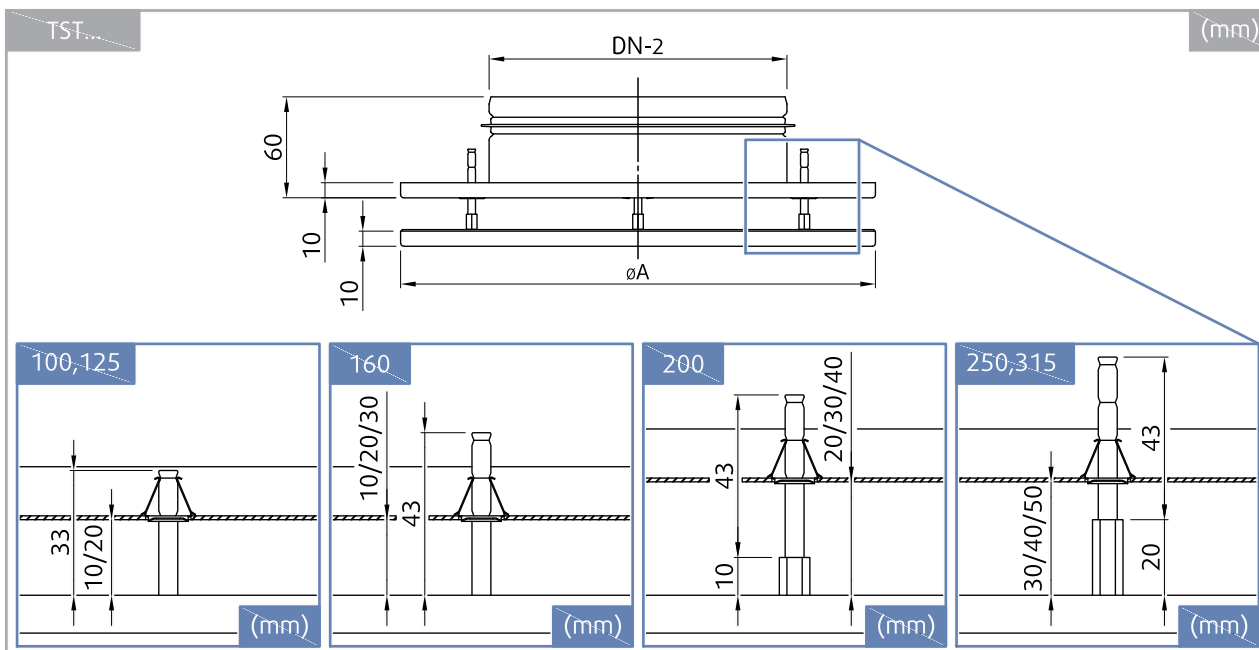

DN	øA	m
	mm	kg
100	199	1,0
125	249	1,1
160	249	1,1
200	314	1,6
250	399	2,3
315	399	2,4

Ordering Codes

TST-

Nominal size (DN)

100

125

160

200

250

315

Surface finish

SW Signal white (RAL9003)

RALXXXX Other RAL colour

Example of the Ordering Code

TST-125-SW

A supply diffuser with nominal size 125, signal white colour.

Accessory

THOR

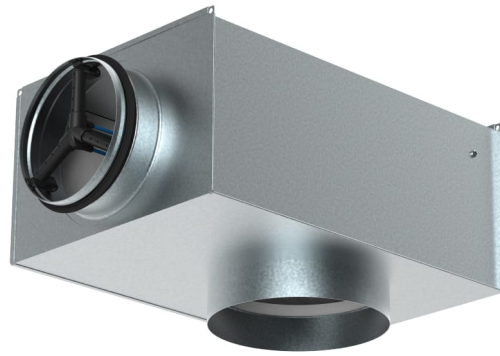

Description

THOR is a plenum box. The product is intended for pressure reduction, airflow balancing and sound attenuation as well as for measuring and adjusting the airflow. The product is used together with air diffusers. The product can be used for air supply and extract.

Accessory

- MB-THOR: Mounting Bridge

Design

THOR is manufactured from hot-dip galvanized steel sheet. The product consists of a plenum box and a duct connection with a rubber gasket. The duct connection is equipped by the ZEUS damper with impulse tubes for measuring differential pressure for flow volume calculation, using a portable measuring device. It can be adjusted manually using a cable gearing.



ZEUS damper

Dimensions

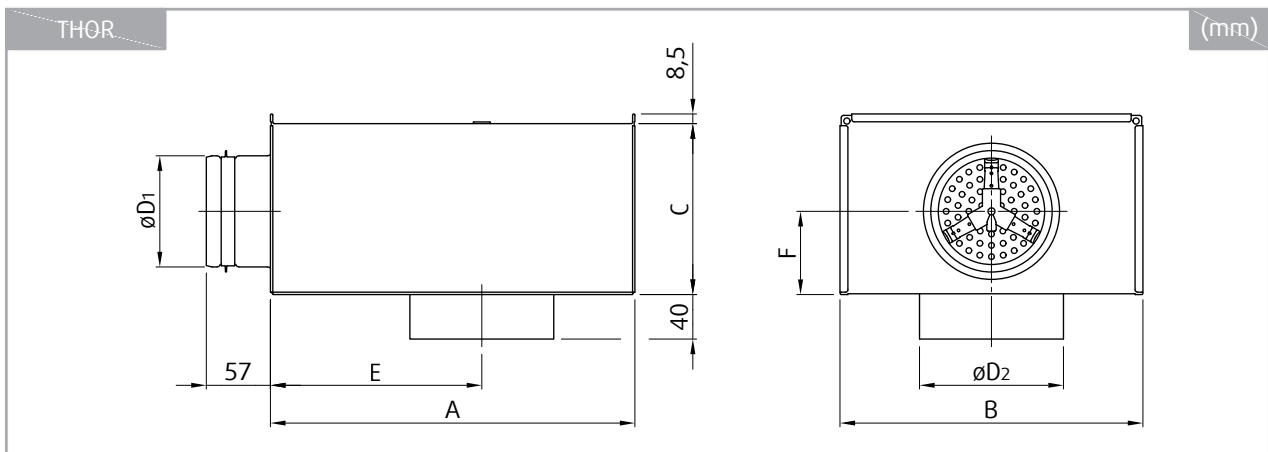

THOR	A	B	C	$\varnothing D_1$	$\varnothing D_2$	E	F	m
	mm							kg
100-125	320	267	150	98	126	185	75	2,5
100-160	360	267	160	98	161	210	80	2,9
125-125	360	267	160	123	126	210	80	2,9
125-160	360	267	160	123	161	210	80	2,9
125-200	450	317	195	123	201	280	98	4,0
160-160	450	317	195	158	161	280	98	4,0
160-200	450	317	195	158	201	280	98	4,0
160-250	500	367	250	158	251	305	125	5,4
200-200	500	367	250	198	201	305	125	5,4
200-250	500	367	250	198	251	305	125	5,4
200-315	565	467	300	198	316	330	150	7,3
250-250	565	467	300	248	251	330	150	7,3
250-315	565	467	300	248	316	330	150	7,3
250-400	620	567	400	248	401	360	200	10,1
315-315	620	567	400	313	316	360	200	10,1
315-400	620	567	400	313	401	360	200	10,1

Ordering Code

THOR-

Nominal size: Inlet-Outlet

100-125

100-160

125-125

125-160

125-200

160-160

160-200

160-250

200-200

200-250

200-315

250-250

250-315

250-400

315-315

315-400

Example of the Ordering Code

THOR-125-160

Plenum box THOR with 125 mm circular inlet and 160 mm circular outlet (nominal dimensions).

Technical Parameters

TST-100-SW

Pressure drop & A-weighted sound power level in dB(A)

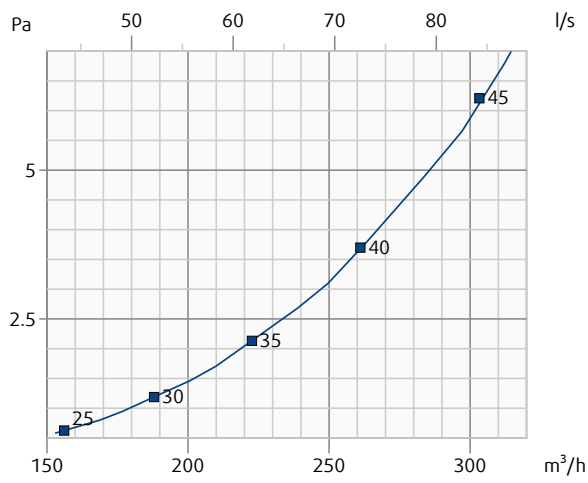

TST-125-SW

Pressure drop & A-weighted sound power level in dB(A)

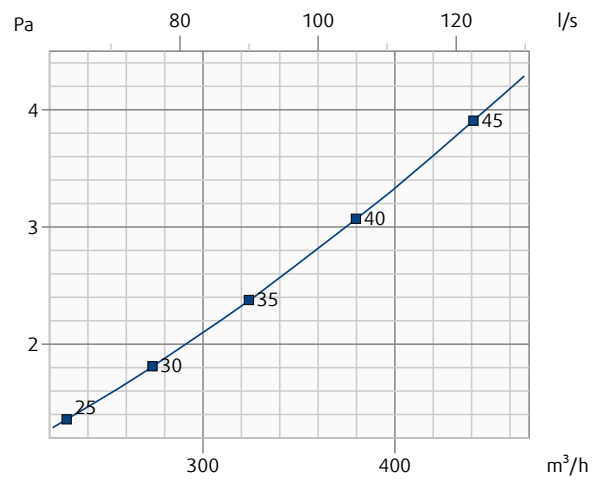

TST-100-SW

Throw length (terminal velocity 0.2 m/s)

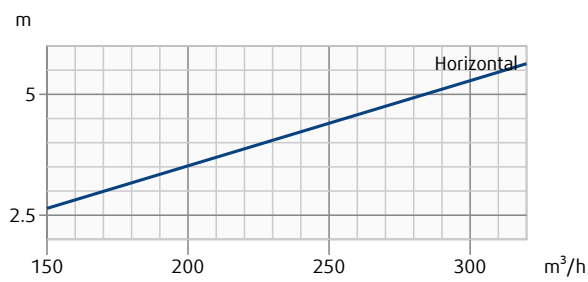

TST-125-SW

Throw length (terminal velocity 0.2 m/s)

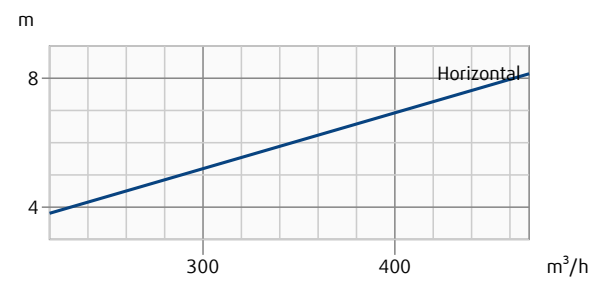

TST-160-SW

Pressure drop & A-weighted sound power level in dB(A)

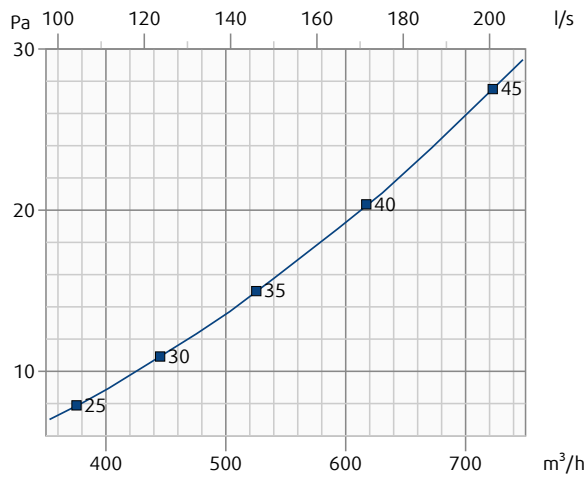

TST-200-SW

Pressure drop & A-weighted sound power level in dB(A)

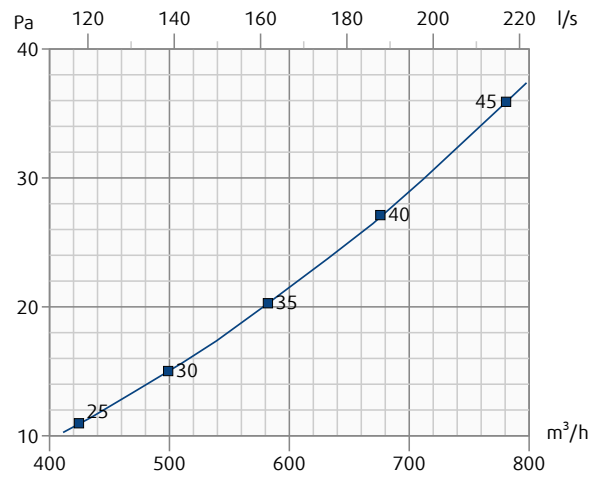

TST-160-SW

Throw length (terminal velocity 0.2 m/s)

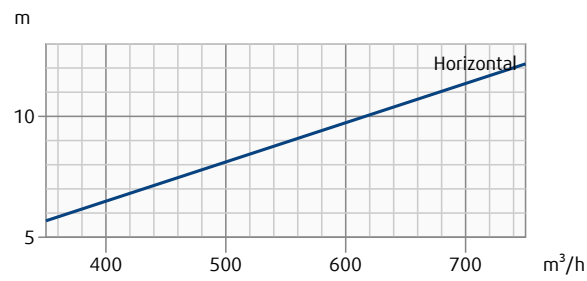

TST-200-SW

Throw length (terminal velocity 0.2 m/s)

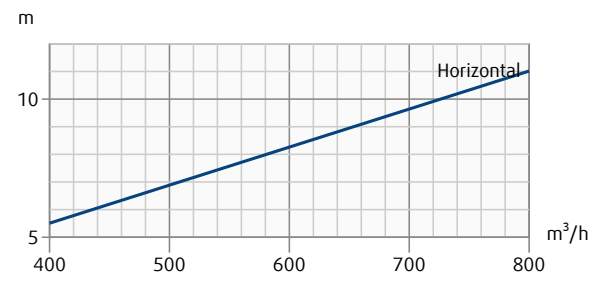

TST-250-SW

Pressure drop & A-weighted sound power level in dB(A)

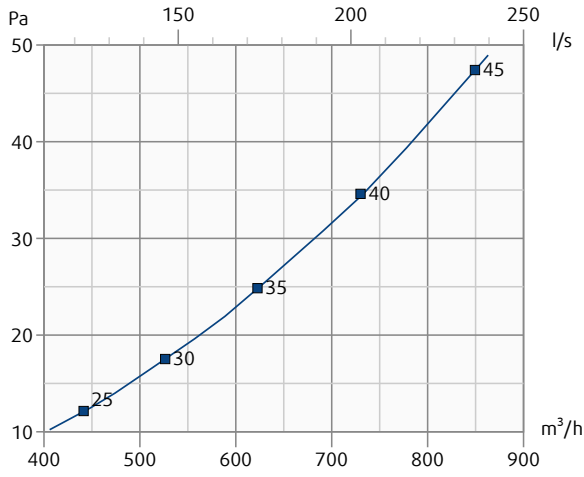

TST-315-SW

Pressure drop & A-weighted sound power level in dB(A)

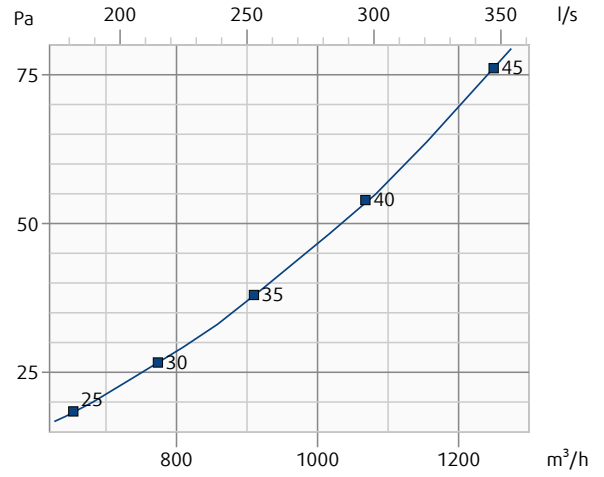

TST-250-SW

Throw length (terminal velocity 0.2 m/s)

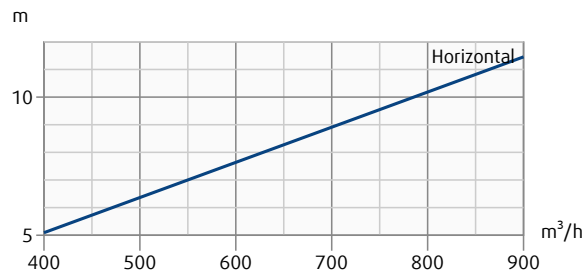

TST-315-SW

Throw length (terminal velocity 0.2 m/s)

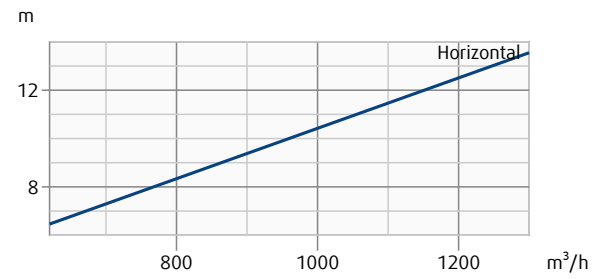

TST-125-SW + THOR-100-125

Pressure drop & A-weighted sound power level in dB(A)

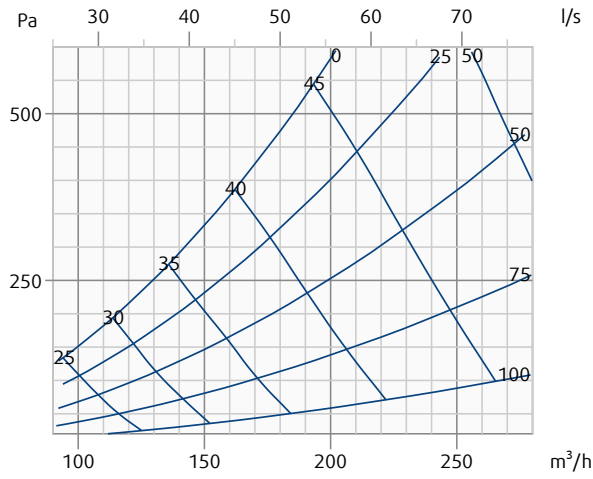

TST-160-SW + THOR-125-160

Pressure drop & A-weighted sound power level in dB(A)

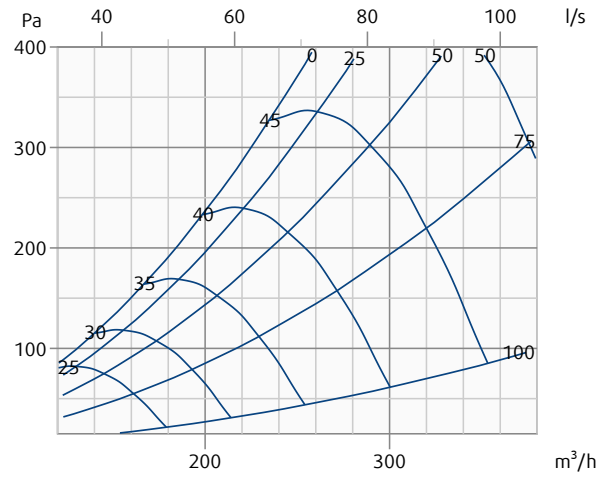

TST-125-SW + THOR-100-125

Throw length (terminal velocity 0.2 m/s)

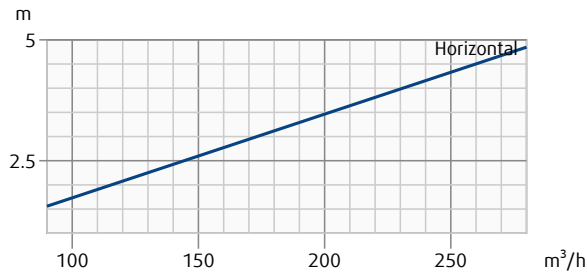

TST-160-SW + THOR-125-160

Throw length (terminal velocity 0.2 m/s)

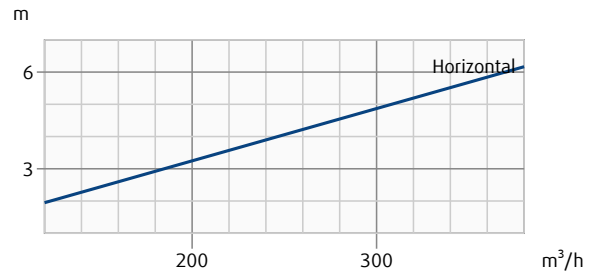

TST-200-SW + THOR-160-200

Pressure drop & A-weighted sound power level in dB(A)

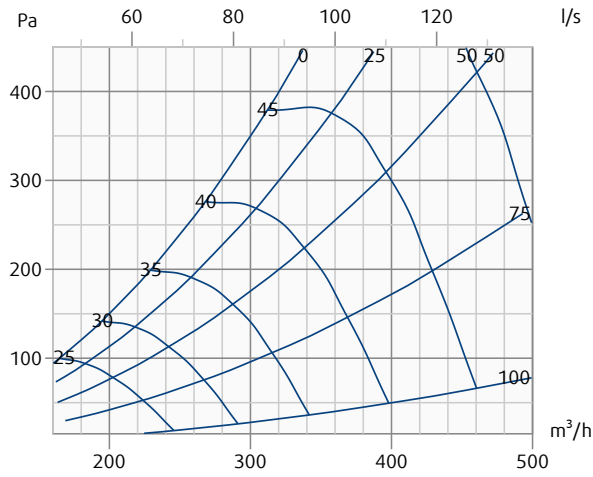

TST-250-SW + THOR-200-250

Pressure drop & A-weighted sound power level in dB(A)

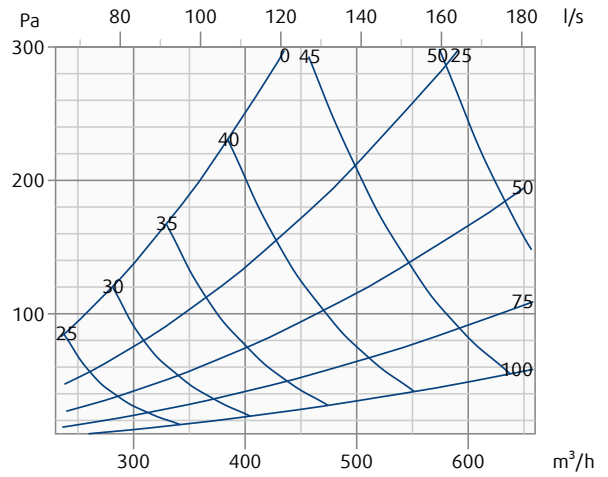

TST-200-SW + THOR-160-200

Throw length (terminal velocity 0.2 m/s)

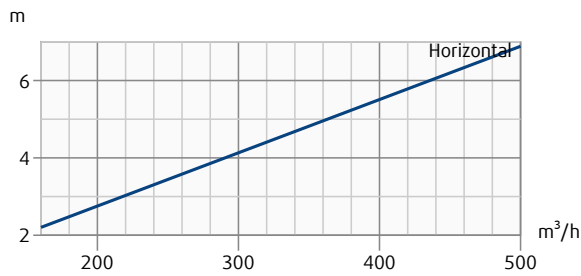

TST-250-SW + THOR-200-250

Throw length (terminal velocity 0.2 m/s)

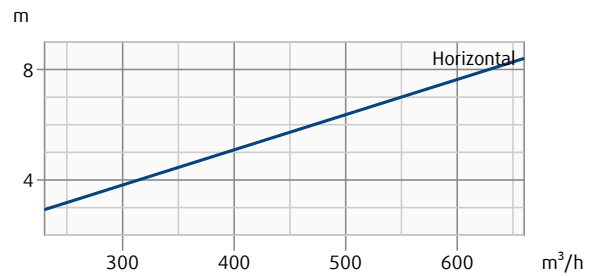

TST-315-SW + THOR-250-315

Pressure drop & A-weighted sound power level in dB(A)

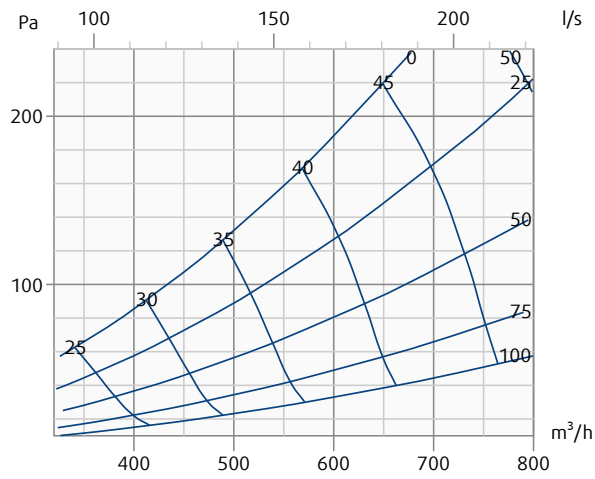

TST-315-SW + THOR-250-315

Throw length (terminal velocity 0.2 m/s)

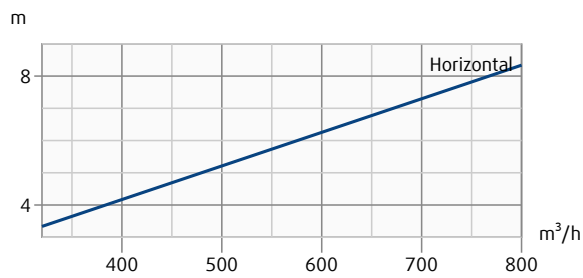

Installation

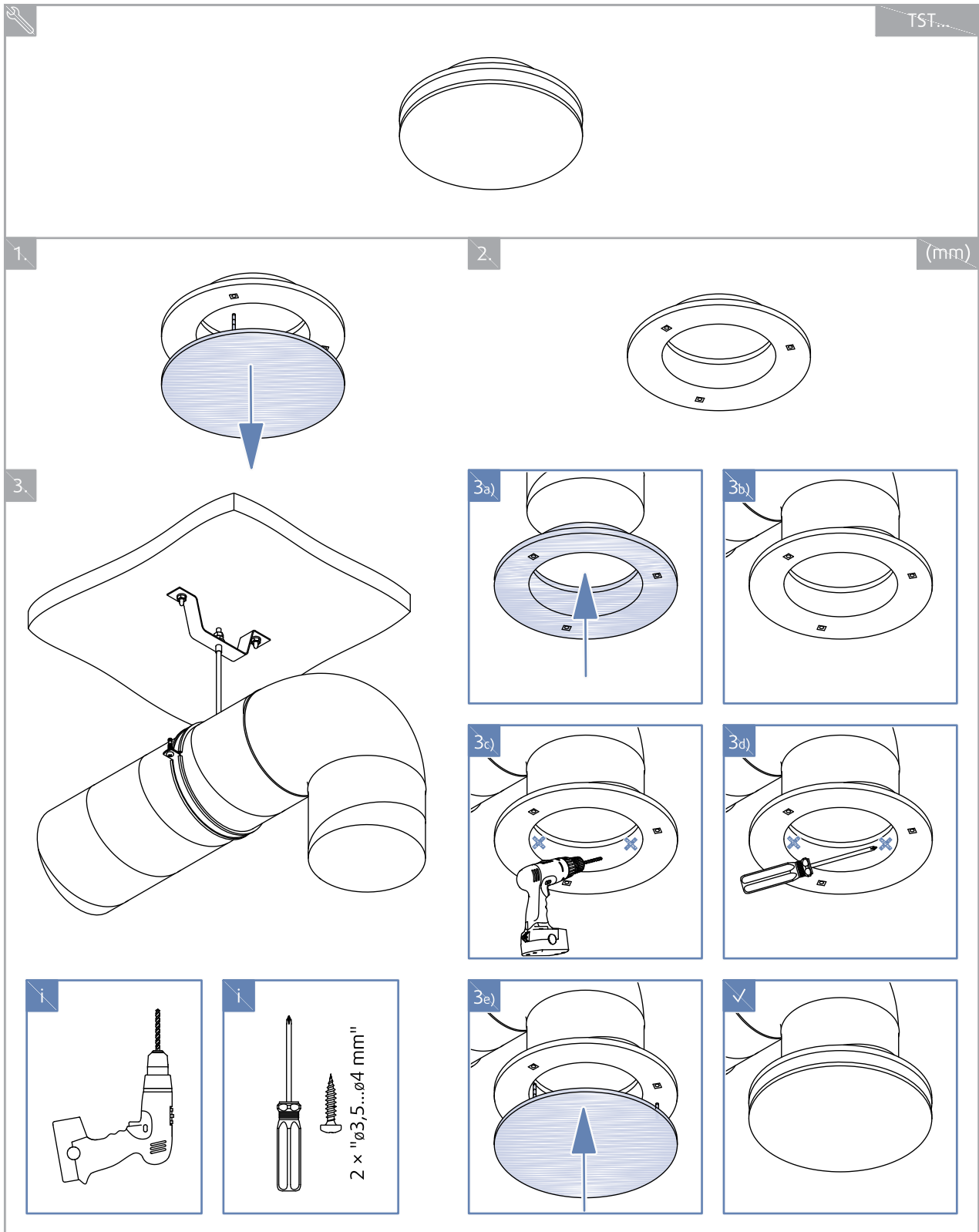

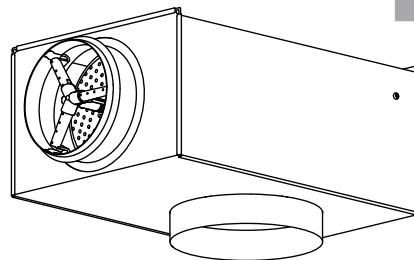
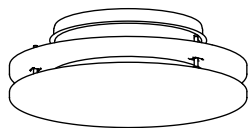

1.

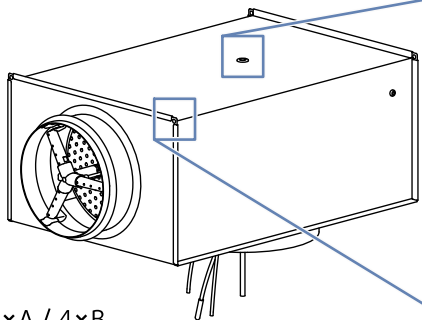

1×A / 4×B

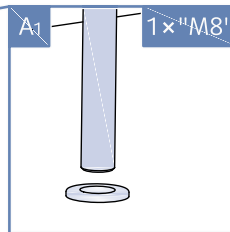

1×"M8"

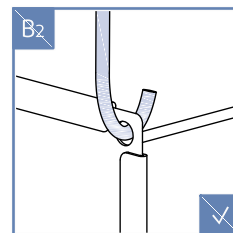
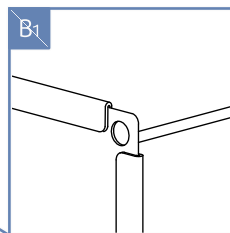
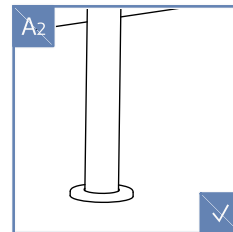

2.

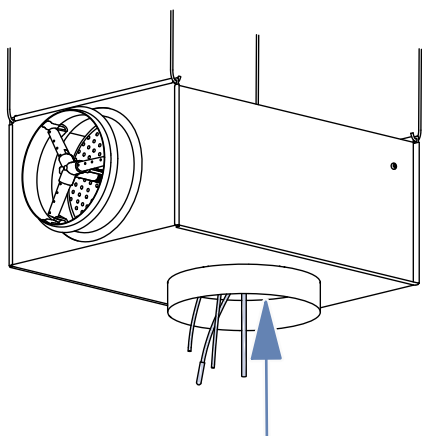

3.

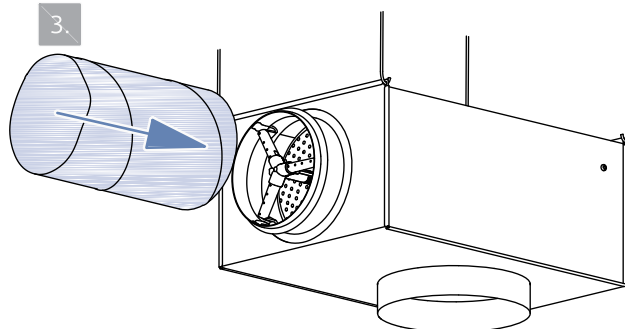

4.

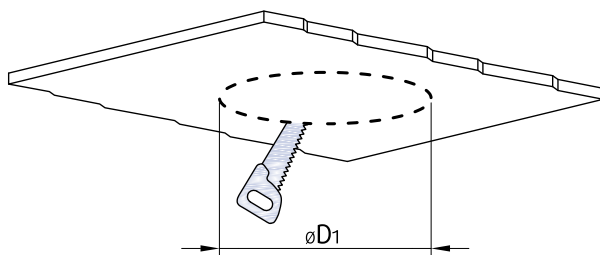

5.

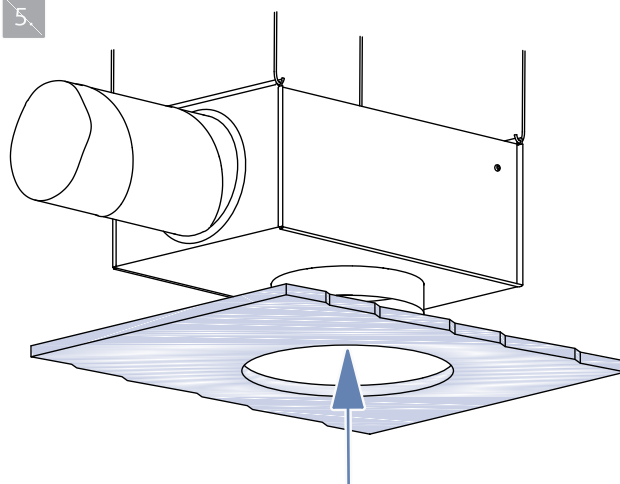

TST-...	100	125	160	200	250	315
$\varnothing D_1$ (mm)	170	220	220	264	349	349

6.

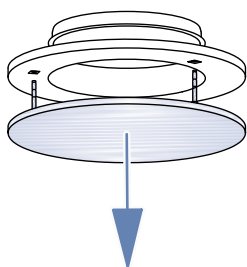

7.

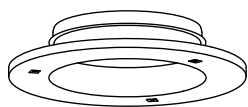

8.

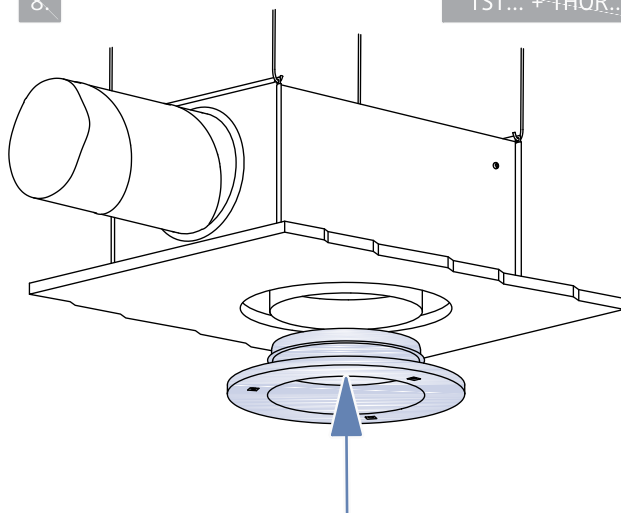

TST... + THOR...

9.

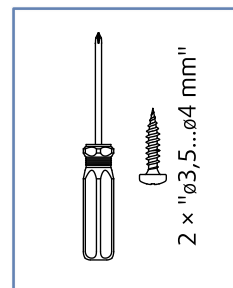
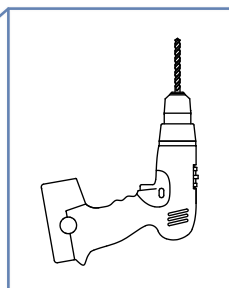
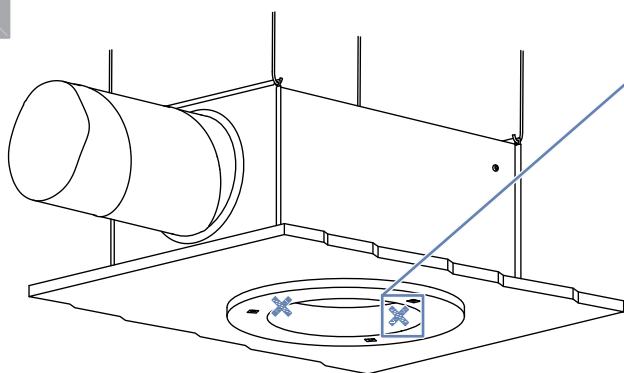

10.

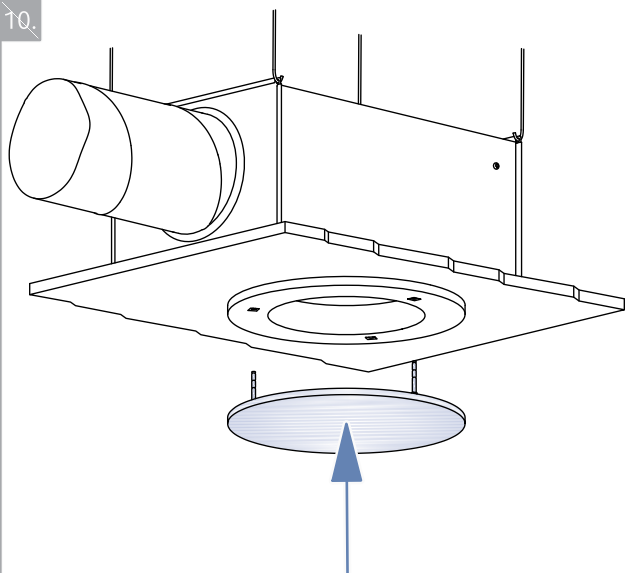

✓

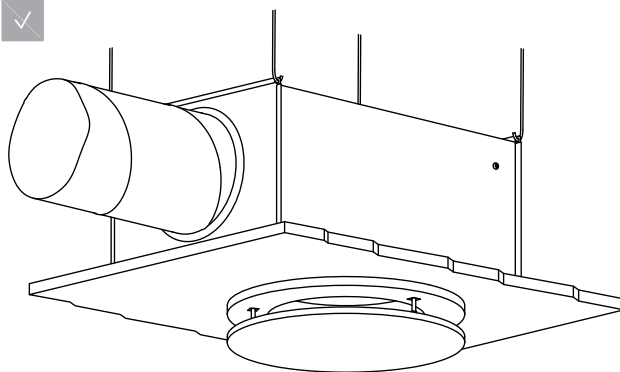

Commissioning

TST... + THOR...

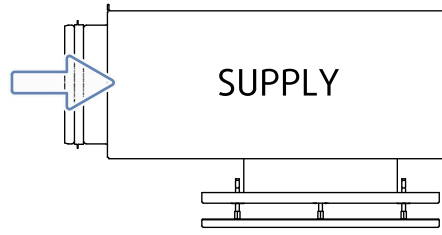

1.

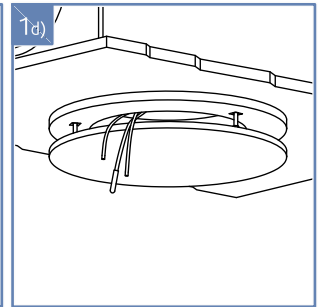
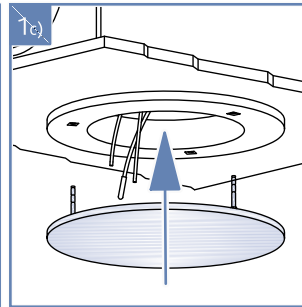
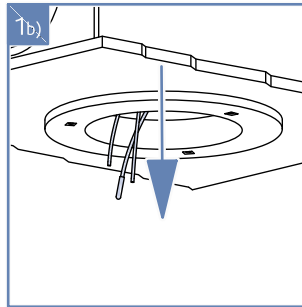
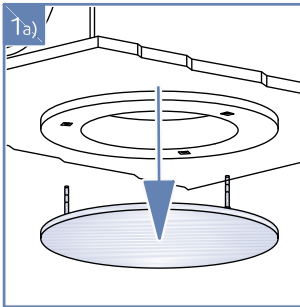
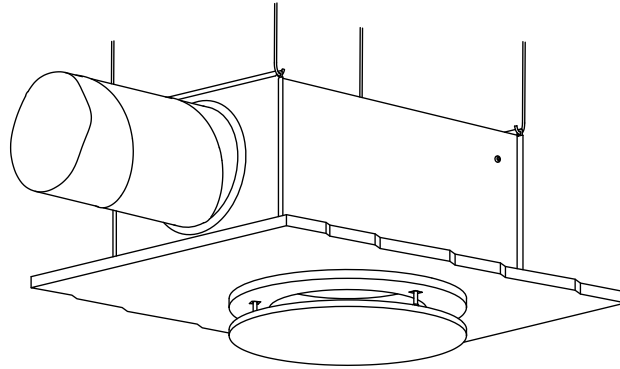

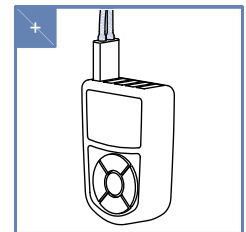
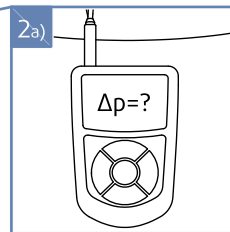
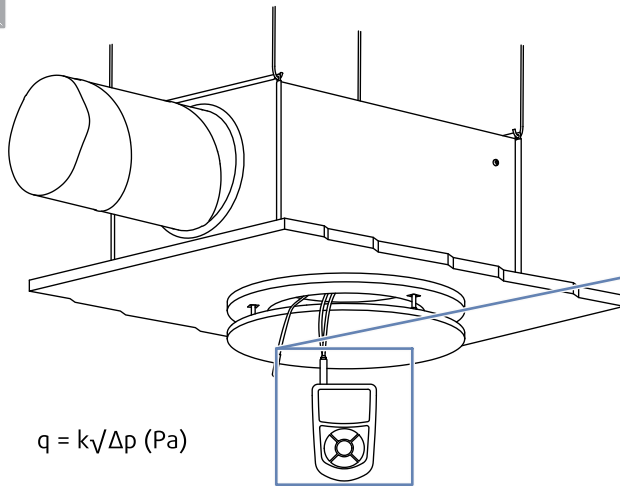

2.

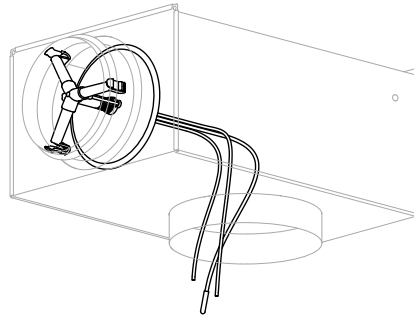

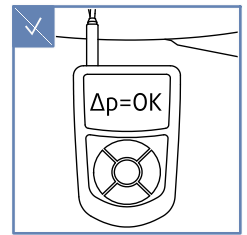
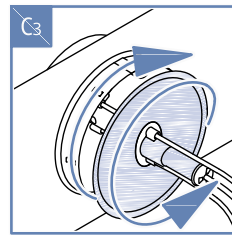
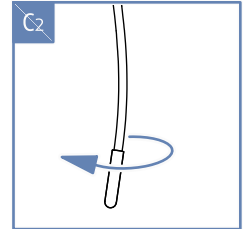
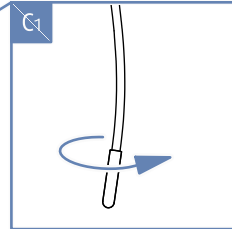
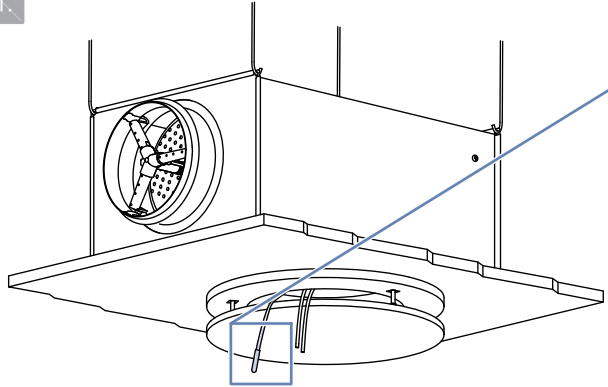

1.



SUPPLY 		k	
TST	THOR	m ³ /h	l/s
125	100-125	19,08	5,30
160	125-160	33,12	9,20
200	160-200	57,24	15,90
250	200-250	93,60	26,00
315	250-315	150,12	41,70

Setup Possibilities

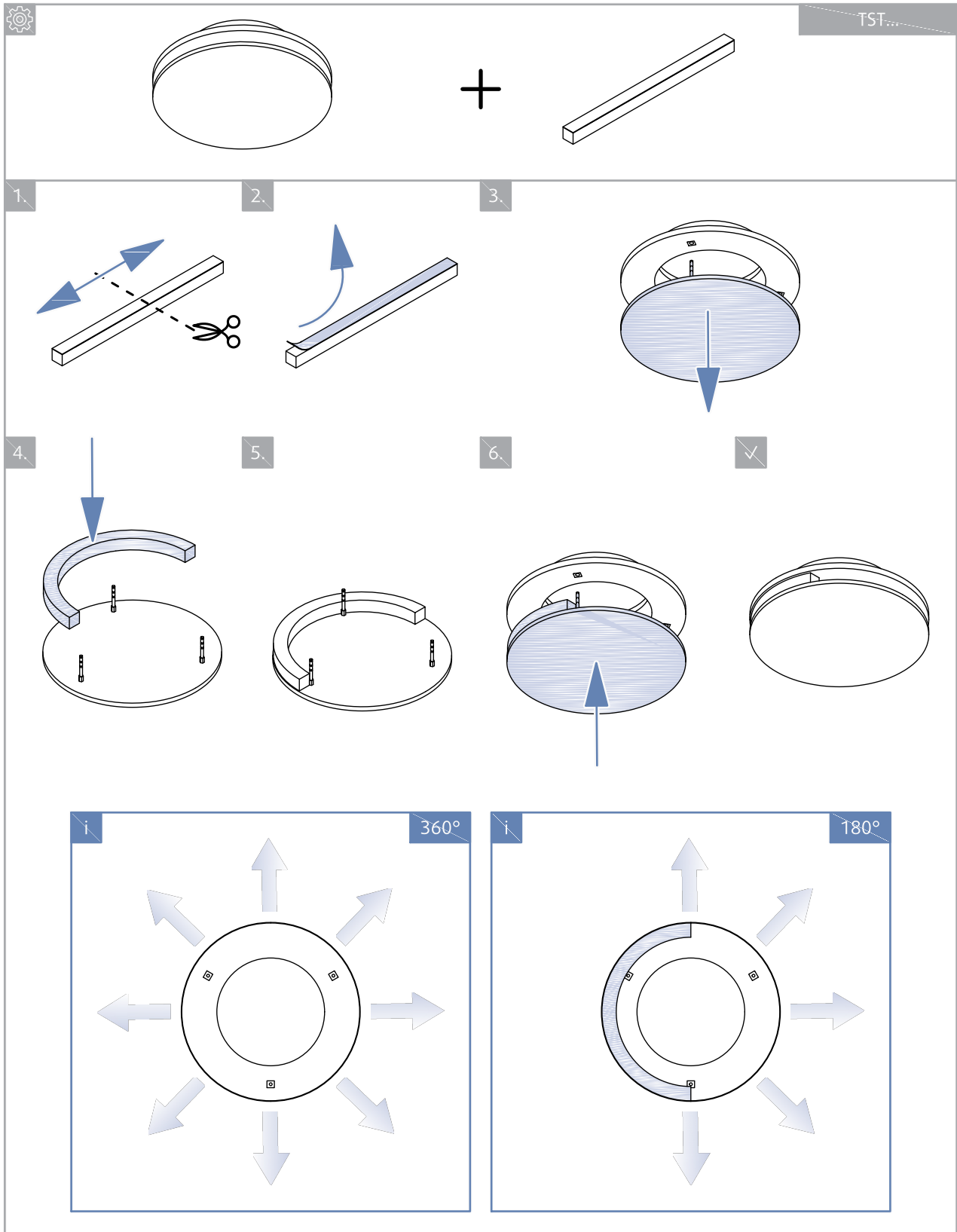

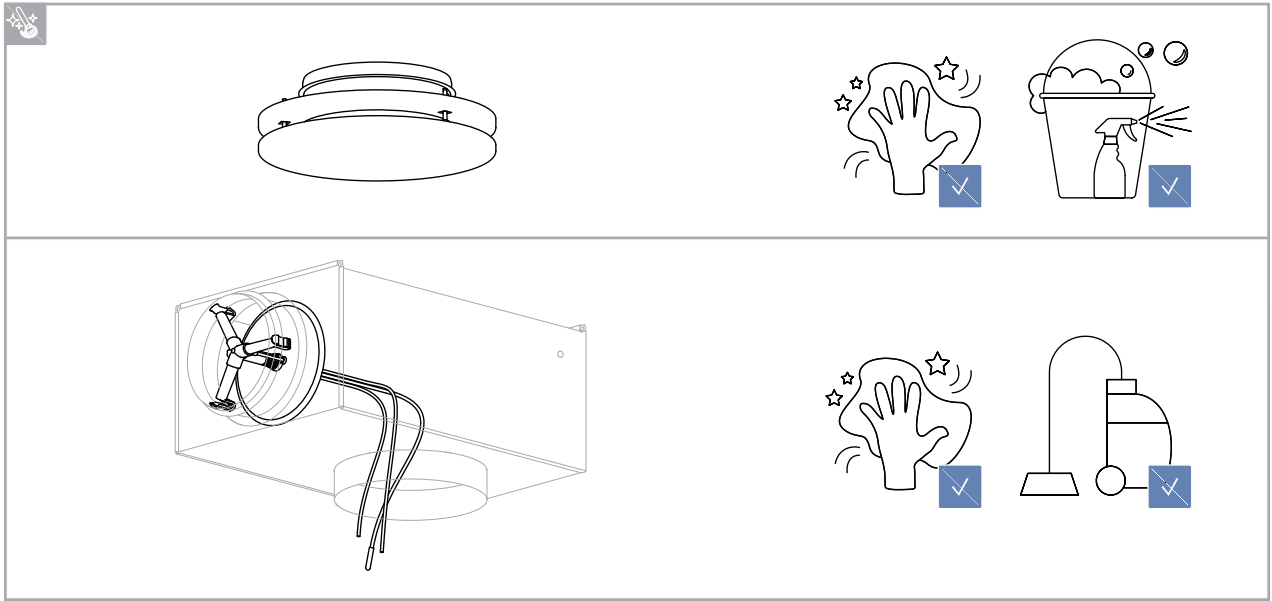

Cleaning

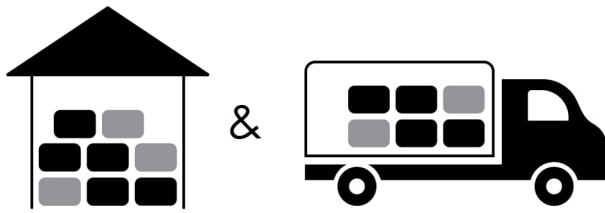

Transport, Storage and Operation



 °C -40 °C ... +50 °C

 % ≤ 95%



 °C -20 °C ... +50 °C

 % ≤ 95%

Supplement

Any deviations from the technical specifications contained herein and the terms should be discussed with the manufacturer. We reserve the right to make any changes to the product without prior notice, provided that these changes do not affect the quality of the product and the required parameters. Current information on all products is available on design.systemair.com.



Handbook_TST_en-GB
design.systemair.com
www.systemair.com

© Copyright Systemair Production a.s
All rights reserved
E&OE

Systemair reserves the right to alter their products without notice.
This also applies to products already ordered, as long as it does not affect the previously agreed specifications.