

# Air Handling Unit

BA+ / BA



By your side for 50 years.  
And counting.









## Systemair worldwide

Systemair is a leading ventilation company with operations in over 50 countries in Europe, North and South America, the Middle East, Asia and South Africa. We develop, manufacture and market high quality ventilation products and solutions. The Company was founded in 1974 on the initiative of Chairman of the Board Gerald Engström. Systemair shares have been quoted on the Nasdaq OMX Nordic Exchange in Stockholm since October 2007, and are today traded on the Large Cap List. The Company has its registered office and headquarters in Skinnskatteberg, Sweden.

## What we do

Systemair offers a wide range of energy-efficient fans, air handling units, air distribution products, air conditioning products and air curtains for different types of premises. We also help our customers in combining these products into total solutions meeting their demands. Our products are robust and simple to choose, install and use.

The Group's products and solutions are marketed under the Systemair, Frico, Fantech and Menerga brands.

## Production and Technology

The Group comprises about 90 companies with more than 6,500 employees, who together work to ensure that Systemair is among the leading players in the global ventilation industry. We have 29+ modern and well-invested production facilities in 18 countries. Systemair's product development organisation consists of more than 250 engineers and technicians with cutting-edge expertise across a range of technologies.

---

**We create better air. Everyday.**

**Worldwide**

# Brand Promise & Core Values

Systemair stands for more than clean air and healthy indoor environments.

## WE PUT OUR CUSTOMER **FIRST**

We meet our customers expectations and offer products and solutions based on their needs.  
From concept to completion, we are at our customers side.



## WE **SIMPLIFY**

We make our customers' jobs easier  
by turning complex systems into smart, easy and sustainable  
solutions.

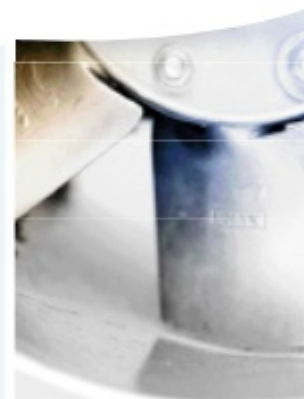

## WE **GUIDE**

We share our deep knowledge and experience to give our  
customers advice and guidance.  
This makes us a trustworthy partner.

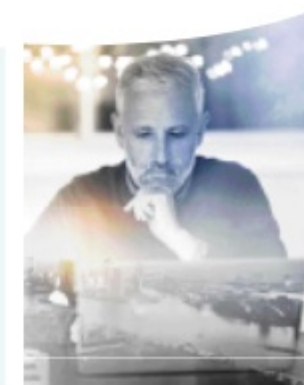



**1974**

Founded in Skinnskatteberg,  
Sweden

**1,100 MEUR**

R12 Turnover  
Annual net sales

**90**

Companies comprised by the  
Group

**10.5%**

Average growth over the  
past 10 years

**2007**

NASDAQ  
OMX Nordic Exchange

**130 MEUR**

Total Book value of our own  
production facilities

**29+**

Production facilities

**>6500**

Employees



# 50+

Countries with Sales Subsidiaries

Always  
close to you!



# A GLOBAL COMPANY

## Production Facilities

1	Kansas City, USA	•		•						•
2	Tillsonburg, Canada			•						
3	Bouctouche, Canada		•							
4	Eidsvoll, Norway			•						
5	Skinnskatteberg, Sweden	•		•		•				
6	Hässleholm, Sweden					•				
7	Århus, Denmark			•						
8	Waalwijk, Netherlands			•						
9	Mülheim an der Ruhr, Germany			•						
10	Langenfeld, Germany					•				
11	Windischbuch, Germany	•				•		•	•	
12	Milan, Italy							•		•
13	Fuenlabrada, Spain	•		•						
14	Móstoles, Spain (2 factories)							•	•	
15	Ukmerge, Lithuania		•	•						
16	Pardubice, Czech Republic (2 factories)		•	•		•				
17	Bratislava, Slovakia							•	•	
18	Maribor, Slovenia			•					•	
19	Dilovasi, Turkey			•	•					
20	Johannesburg, South Africa	•		•	•				•	
21	New Delhi, India	•		•				•	•	•
22	Hyderabad, India			•				•	•	
23	Kuala Lumpur, Malaysia	•							•	•
		Fans	Residential ventilation	Air handling units	Air conditioning	Air curtains and heating products	Products for air distribution	Fire safety	Garage and tunnel ventilation	Filters



LEED certified Platinum rated Unit, India.

## SYSTEMAIR IN INDIA

Systemair has a well-established footprint in India with three state-of-the-art production units strategically located in Greater Noida and Hyderabad. With a total production area spanning around 20,000 square meters, these facilities epitomize innovation and sustainability in the ventilation industry in the region. The Systemair India head office in Greater Noida is LEED Platinum certified. The production facilities in Greater Noida and Hyderabad are modern and well-invested, with 690+ well-trained staff members having a strong focus on quality.

At the heart of Systemair's operations in India lies a commitment to sustainability. Through cutting-edge technology and forward-thinking practices, Systemair India produces air distribution products, air handling units, fans, and fire safety products that not only meet the highest standards of performance but also contribute to reducing CO2 emissions in the environment.

The factory is also equipped with a Research and Development and testing facility, which contributes to the high level of perfection in product performance.

Systemair India is a 9001:2015 and 14001:2015 Certified company.



At Systemair, we are aware of our responsibility towards the environment. Our main contribution to modern environmental protection is efficient use of energy. The Green Ventilation symbol identifies intelligent technology in harmony with the environment.





Manufacturing Facility, India.



Air Flow Chamber, India.

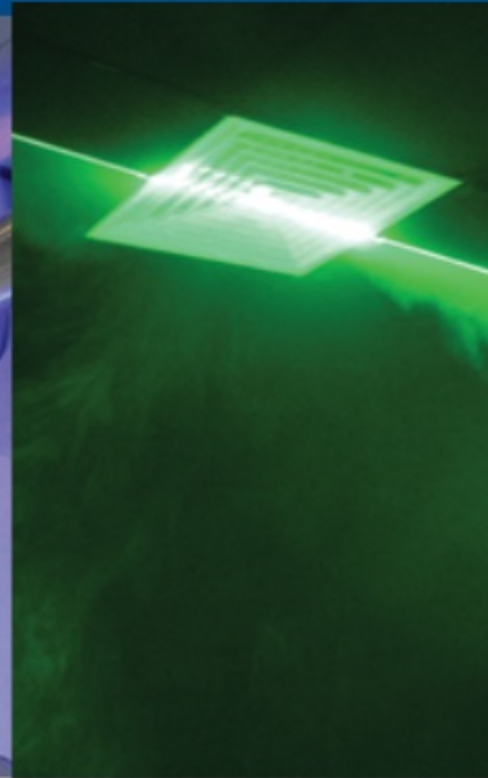

ATD Lab, India.

## PRODUCT RANGE

The range of products manufactured in India includes -

### Air Handling Units



### Air Distribution & Fire Safety

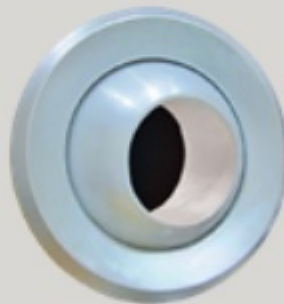

### Fans



## CERTIFICATIONS



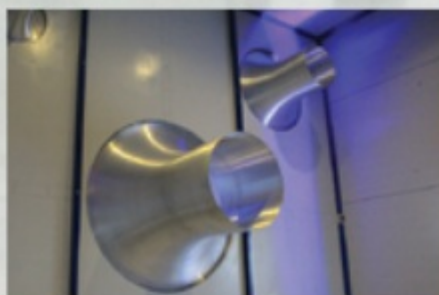





## R&D Centre

# Asia's first AMCA accredited laboratory

The Indian technical centre in Greater Noida unit has Asia's first AMCA accredited laboratory for measurements as per AMCA 210 & AMCA 300 standards. The technical center has most modern facilities for measuring air flow, sound levels, pressure & energy consumption. The measurements performed in the lab are in compliance with EN 12238.



### Precision Testing:

- Systemair operates test facilities that are accredited by the Air Movement and Control Association (AMCA) in Sweden, U.S.A & India
- 13+ Technology centres in more than 16 countries.
- The laboratories are equipped with 4 major measurement chambers- acoustic, airflow, air terminal lab & climate chamber.

# Systemair products in the community

Systemair helps create a healthy, comfortable, and safe indoor climate in most areas where people spend time daily. We do this in the knowledge that good air quality contributes to a better quality of life. We also do this in an energy-efficient way to contribute to a more sustainable society. Systemair offers a wide range of solutions suitable across all application areas and applications.

## Our group-wide application areas

Education

Hospitality &  
Entertainment

Residential

Commercial





Infrastructure & Transport

Industrial

Healthcare

Data centre



# Exactly what you need...

Fresh air adds so many meanings to life. Fresh air is a blessing that we tend to take for granted. By investing in an energy efficient ventilation system from Systemair you get a healthy indoor environment while reducing your operating costs.

Additionally, it prepares you for future environmental requirements and thus increases the value of your property. In other words, pure profit.

We at Systemair constantly strive to develop new solutions and products that offer that fresh, beneficial breath of air in a cost effective, sustainable way.

Our new BA+ is the latest outcome of Systemair's ambition – an integrated solution that is easy to configure for your needs, with easy installation and fast delivery.

Because at Systemair, we want you to be able to focus on what's important for you, relax and enjoy life.



# BA+

Introducing  
the new BA+  
Sustainable  
solutions like  
never before.

Highest flexibility for infinite  
solutions.



# BA+

We created BA+ and designed it to be easy to work at every step of the way. Our configurator helps you select the best unit for your requirements. Our standardised design with built-in flexibility reduces lead time and ensures fast delivery and easy installation. The Systemair control system makes it simple to connect, configure and control. All products are also manufactured to comply with environmental requirements. To ensure easy installation, many of these units feature control systems enabled for plug-and-play, i.e. simple start-up.

These are a few of the things that make BA+ not only right for your building's air flow but also for your work flow.



## Certified Units

EUROVENT certified BA units are available in different versions and meet both comfort requirements as well as the most demanding ventilation needs.



## Easy to select

Easy to select, design and configure air handling units  
Real-time 3D visualization of air handling unit and accessories



## Perfect Fit

Quality, optimization, reliability and efficient calculation of modules ensures the best performance with a low pressure loss that is crucial for the safe operation and energy efficiency of the units.

Casing Strength	: D1
Casing Air Leakage	: L1
Thermal Bridging Factor	: TB2
Thermal Transmittance	: T2
Filter Bypass Leakage	: F9



### Software Program

Selection Program named **Systemair BAHU** is tested & certified by **EUROVENT**

### Label Indication (Summer/ Winter)

The Energy Efficiency Class for Summer and Winter Applications may be different and are indicated separately.



## Examples Of Applications

Our air handling units are designed in modules. The module can be configured for different applications to make up the heart of any air conditioning system. The flexibility makes it possible to optimize the air handling unit for specific requirement.

---

### Pharmaceutical Industries

Our Air Handling Units are designed to minimize the introduction, generation and retention of particulate and microbial contaminations. Hence, they are indispensable for reducing or avoiding airborne pathogens and maintaining an unobjectionable climate inside.

---

### Clean Room Solutions

Clean rooms can encompass numerous applications, everything from operating theatres to laboratories. Systemair's range of air handling units can satisfy all requirements relating to healthcare, whether these have to do with air cleanliness, noise levels or demand control.

---

### Plug & Play Solutions

Integrated control systems. Our factory-integrated solutions are designed with various levels of equipment that can handle everything from the simplest requirement to the toughest demands.

---

### Flexible Solutions

Flexible solutions with heat recovery and intelligent control functions that are easily adapted to suit current needs of different recovery systems and configurations.

---

### Compact Solutions

Extreme space-saving solutions and new connections for units that can also be split. Completely adaptable to satisfy all new demands. Compact air handling units are easier to transport and handle at the construction site.

---

### Industrial Solutions

Air humidifiers can be installed in air handling units, which makes it suitable for air cooling, water spray humidifier and scrubber applications.

---

### Comfort Solutions

Simple project implementation for expansion of existing premises or new buildings. Simplifies selection and planning and includes smart solutions for easier installation.

# Air Handling Units

Modular & extremely adaptable

Systemair has a wide range of air handling units for use in various applications from small office premises to larger industrial applications. Common to all items in the range is that, systems and components have been developed to satisfy stringent demands for low energy consumption. Heat exchangers, motors and fan units have all undergone extensive testing, both in the laboratory and out in the field, in order to comply with current and future demands for low energy consumption.

All products are also manufactured to comply with environmental requirements. To ensure easy installation, many of these units feature control systems enabled for plug-and-play, i.e. simple start-up.

## BA+ Units

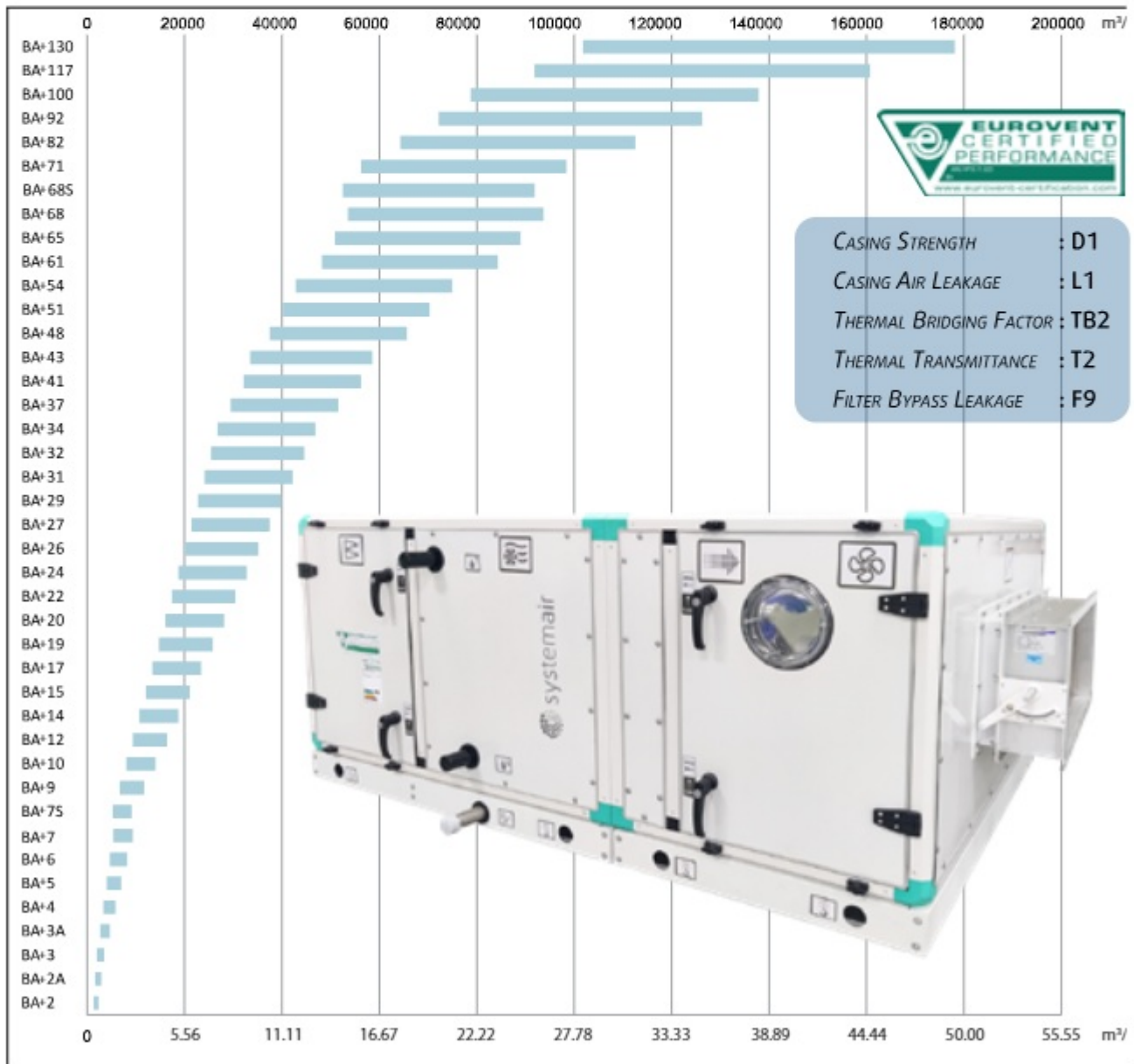



## Facts about AHU

- BA\* and BA units are Eurovent certified
- Handles airflows of 1000-178000 CMH
- For use with medium or high air pressure systems.
- Heating and cooling units
- Extensive range of filters & Heat recovery sections
- Static pressure upto 2300 pa

## BA Units

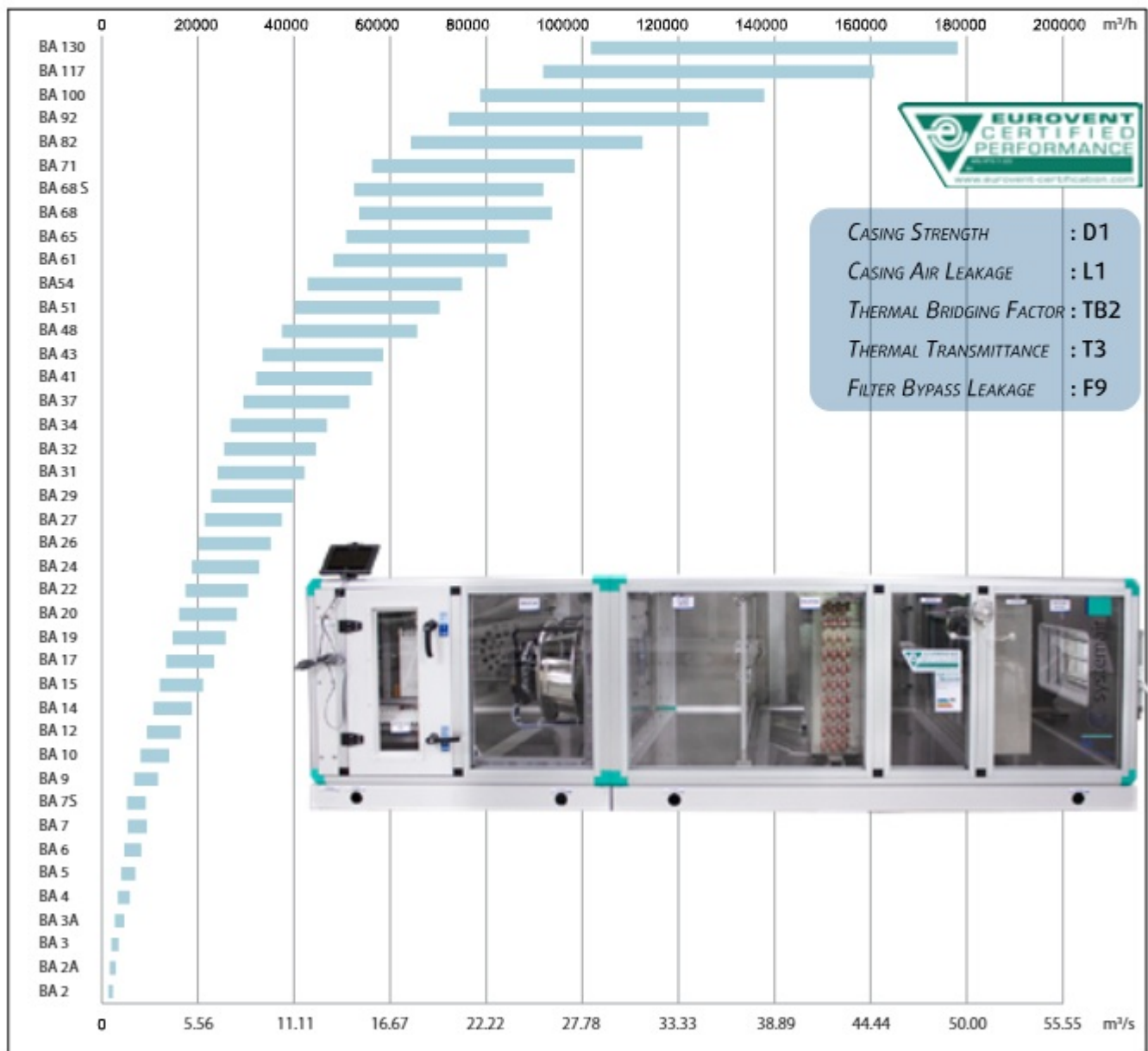

# Components of air handling units



## Tightness/corners.

Framework of airtight, elegant & sturdy extruded aluminium hollow profile with polyamide thermal break profile having glass filled nylon corners & spacers.



## EC fan.

A wide range of EC fans can be offered.

## Fan/motor.

A variety of fans can be offered based on the requirement.

- Belt driven DIDW centrifugal FC/BC fans
- Centrifugal plug fan
- Motors with IE2/IE3 efficiency
- PM motor with IE4/IE5 efficiency
- Low noise high efficiency axial fans with PM motor



## Heat transfer coils.

Copper tube aluminium finned heat transfer coils available in multiple rows deep and are designed to give certified performance output for heating, cooling & recovery applications



## Control system.

Units can be provided with factory tested control systems for all necessary standard functions and the settings can be easily adjusted to desired operational values.



## Inspection doors/handles.

Adequate sized inspection doors are provided in each section fitted with high quality comfortable handles.







**Supply and extract filters.**

Units are offered with high quality & low pressure drop filters of different particulate efficiency.



**Supply and extract dampers.**

low-leakage extruded aluminium dampers suitable for manual or motorised operations.



**Base frame.**

The base frame is made from strong galvanized steel with lifting provision.



**VFD.**

Units are supplied with single speed motors. To regulate the fan speed to its actual point, frequency converters can be provided.

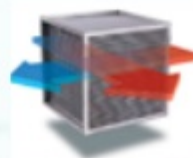

**Heat exchanger.**

High quality and energy-efficient heat exchangers are available: rotary heat exchanger, plate type heat exchanger, heat pipes or run around coil heat exchanger.

## Casing

The metal enclosure that covers all the components contained in the Air Handling Unit is sturdy and has no protruding items to disturb the overall look of the unit.

Air handling units have a frame composed of an extruded aluminium section that outlines the equipment edges perfectly, resulting in a solid, robust and attractive overall look.

These aluminium extruded sections are joined by injection-moulded glass-reinforced nylon corner & spacers.

The unit enclosure is made up of sandwich panels comprising two pieces of metal sheets one inside the other.

The inner rack is manufactured of aluzinc, stainless steel or galvanised steel sheet, whereas the exterior rack of the same material has precoated/ aluzinc finish. The insulation material between the two racks is either machine injected polyurethane foam insulation or rockwool to ensure excellent thermal & sound insulation.

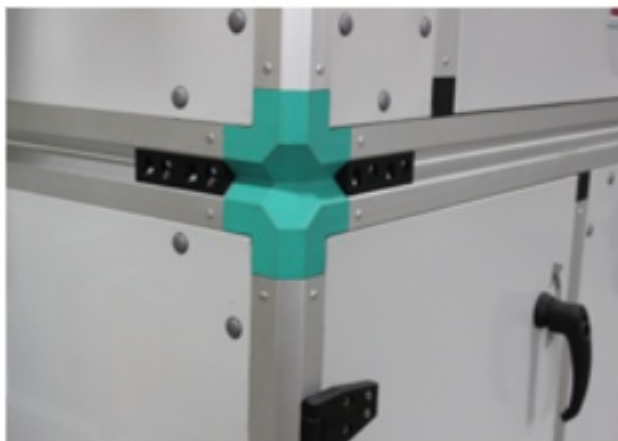

The AHU panels are manufactured in nominal thickness of 50mm which are mounted on a frame composed of an aluminium profile, which outlines the equipment edges precisely.

Regardless of the type of structure, all panels on the access side can be easily dismantled, thereby facilitating access to the internal parts of the air handling unit by the maintenance staff.

The finished equipment can have a bedplate composed of channel sections or feet. Based on the project needs, it can also be set on shock absorbers when vibration must be avoided.

The enclosure described contains all the air handling unit sections, which can include some or all of the ones

described below:

### Inlet Section

This section is composed of a standardised length with an air inlet to the air handling unit.

This opening can:

- Use a volume control damper that can be equipped for manual operation or for subsequent automation.
- Be equipped with a simple inlet consisting of a straight flange for easier duct connection;

In addition, a cover to prevent water from entering when the equipment is placed outdoors can be provided.

### Mixing Section

This has similar features as the above and two openings, each of which contain a control damper.

These dampers can be supplied with an extruded aluminium section construction having airfoil blades.

The operating mechanisms for all dampers are installed in the channel frame. This allows air to circulate freely and facilitates installation in closed ducts. The mechanisms and fasteners are made of corrosion-resistant materials.

The operating mechanism of the dampers may be manual or equipped for motor-driven operation. In the latter case, upon request and depending on the damper size, these controls can be supplied interconnected so they can be operated by a single servo drive.

### Free Cooling Section

This section requires a return fan and a supply fan. These fans must have three dampers in between to regulate the volumes of exhaust, return and outside air. Therefore, in order to meet their purpose the dampers must be motor-driven.

When the enthalpy of the outside air is less than the enthalpy of the recirculated air, i.e., during spring and autumn, the mixture of outside air and recirculated air is controlled to achieve free cooling.

Consequently, the relative opening of the dampers is determined by an enthalpy (or dry temperature) comparator, which sends the respective signal to the damper motors.

In order to ensure the minimum ventilation air required in cooling or heating seasons, the outside air inlet damper can be split into two sections (one motor-driven and another manual that remains fixed). The cross-section of the damper will be proportional to the minimum



ventilation air flow.

This effect can also be achieved more economically by adjusting the stroke of the motor operating the outside air damper so it does not close completely.

### Access Section

This section, which has a hinged access door and is equipped with an enclosure and handle, is sandwiched in the air handling unit configuration to allow access to the lower parts that require surveillance or regular maintenance.

It may also be used to hold any type of auxiliary component, such as a perforated jet humidifier for direct humidification with steam, or other types of components.



*Door hinge*



*View window*

*Door handle*

### Filters

One of the purposes of the air handling unit is to ensure the purity of the room air. Air filtering is related to the quantity, variety and size of the suspended impurities, the existence of contaminant gases or odours, and the desired filtering efficiency. The various impurities that can exist in the air are discussed below.

The air contains numerous foreign substances caused by natural processes (e.g., wind erosion, sea evaporation, soil movements and volcanic eruptions) and by human activity (e.g., combustion). Atmospheric dust is a mixture of fog, combustion gases, fine dry particles and fibres. Air testing normally indicates the presence of soot and smoke, quartz, soil, residue from decomposed animals and vegetables, organic substances in the form of cotton and plant fibres, and metal fragments. The air also contains other organisms such as microorganisms, spores and pollen.

Particle size is expressed in microns (10-6 µm). Air contains particles with a size of up to 0.01 microns and other particles with a thickness similar to fibres, leaves, etc. Dust is generally understood to mean particles under 100 microns. The particle size distribution of particles in atmospheric dust can be measured in several ways. There are two widely acceptable standards defining the filtration performance of filters for general ventilation - the well-known EN 779 and the new global standard EN ISO 16890. The coexistence period for both standards came to end in 2018 and after that EN 779 has become obsolete.

Both standards deal with the evaluation of the filtration effect of coarse and fine dust filters used in general ventilation. Yet, in EN 779, the efficiency classification for medium and fine filters is based on 0.4 µm particles, while the new EN ISO 16890 defines the efficiency for various fractions of particle size: PM10, PM2.5 and PM1.

The High Efficiency Ventilation Filters (having initial efficiency with atmospheric dust greater than 98%) like the EPA, HEPA and ULPA filters are classified and tested according to EN 1822 standard. They are not included in ISO 16890.

The standardised range for the BA\* & BA Air Handling Unit includes three air filtering sections which, combined with the wide variety of filtering materials, covering an extensive range of possibilities in filtering efficiency.

#### Extended surface filters

Characterised by a specific type of pleat which produces a larger filtering surface. The pleat design, as well as the alignment between the pleats, ensures uniform air circulation over the surface of the filtering media.

The extended surface filter is composed of a frame,

filtering media in zigzag layout, and electrowelded mesh to hold the media. Its advantages with respect to flat filters are:

- Greater filtering surface;
- Reduced front air velocity;
- Greater efficiency;
- Greater dust retention capacity;
- Reduced front surface.

The filters correspond to Classes G1, G2, G3 and G4 of Group G (coarse-dust filters) and Classes M5, M6 of Group M and F7 for Group F (fine-dust filters), as per EN 779. As per ISO 16890, the filters correspond to ISOePM1, ISOePM2.5, ISOePM10 and ISOePMCoarse.



*Extended filter.*

### Flexible bag filters

The flexible bag filters allow a high filtering flow rate in relation to the front surface area. Constructed with fibreglass (greater efficiency) or synthetic fibre (lower efficiency) filtering media.

Flexible filters have the following advantages:

- Lower power requirement.
- Longer filter renewal interval.
- Lower energy costs.
- Lower maintenance.

These filters have a medium to high efficiency and correspond to Classes M5, M6 of Group M, F7 and F8 of Group F (fine-dust filters) as per EN 779. As per ISO 16890, the filters correspond to ISOePM1, ISOePM2.5, ISOePM10 and ISOePMCoarse.

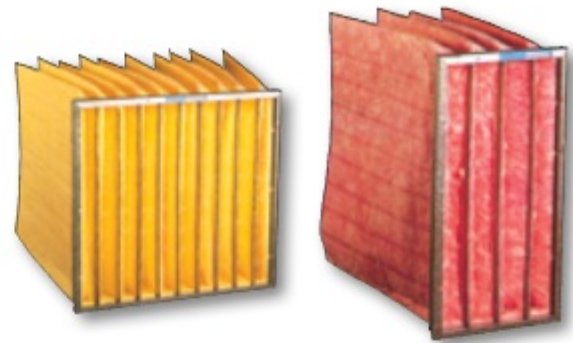

*Flexible filter.*

### Rigid bag filters

Rigid bag filters have similar filtering capacity as flexible bag filters with the following advantages:

- Solid, sturdy construction for fast, easy installation.
- Compact, reduced-volume design.

They have a medium to high efficiency and correspond to Classes M5, M6 of Group M, F7, F8 and F9 of Group F (fine-dust filters) as per EN 779. As per ISO 16890, the filters correspond to ISOePM1, ISOePM2.5, ISOePM10 and ISOePMCoarse.

Both the rigid and the flexible bag filters are specially recommended for:

- Hospitals.
- Pharmaceutical companies.
- Food industries.
- Computer rooms.
- Office buildings.

Likewise, both rigid bag filters and the flexible bag filters of Class F8 and F9 trap particles below 6 microns, which correspond to the smallest particles of those in temporary suspension that are visible under a microscopic.



*Rigid filter.*



## Dimension Table

Class	EN779		Eurovent 4/5	ASHRAE	ISO 16890*
	Ability to separate synthetic dust, Am	Mean value of the collecting efficiency, Em			
G1	$50 \leq Am < 65$	-	-	-	
G2	$65 \leq Am < 80$	-	-	-	
G3	$80 \leq Am < 90$	-	EU3	G85	
G4	$90 \leq Am$	-	EU3	G90	ISO Coarse 30% - 95%
M5	-	$40 \leq Em < 60$	EU5	F45	
M6	-	$60 \leq Em < 80$	EU6	F65	ISO ePM10 50% - 95%
F7	-	$80 \leq Em < 90$	EU7	F85	ISO ePM2.5 50% - 95%
F8	-	$90 \leq Em < 95$	EU8	F95	
F9	-	$95 \leq Em$	-	-	ISO ePM1 50% - 95%

\*A 1-to-1 comparison is not possible, but there are similarities with EN 779, which are shown here.

## Absolute filters

Require careful installation that guarantees complete air-tightness of all gaskets. They are designed to eliminate virtually even the smallest particles in the air, i.e., those in continuous suspension (the smallest of these are only visible using electronic microscopes).

They are specially recommended for:

- Hospitals.
- Food industries.
- Pharmaceutical companies.
- Clean rooms.
- Absolute filtering of air in environments with controlled contamination.

They should be installed immediately before the space requiring this virtually sterile air that these filters can supply.

They correspond to Classes H10, H11, H12, H13 and H14 of Group H: absolute filter, HEPA and ULPA, as per UNE-EN 1822.



*Absolute Hepa filters.*

CHARACTERISTICS OF THE MAIN ATMOSPHERIC POLLUTANTS

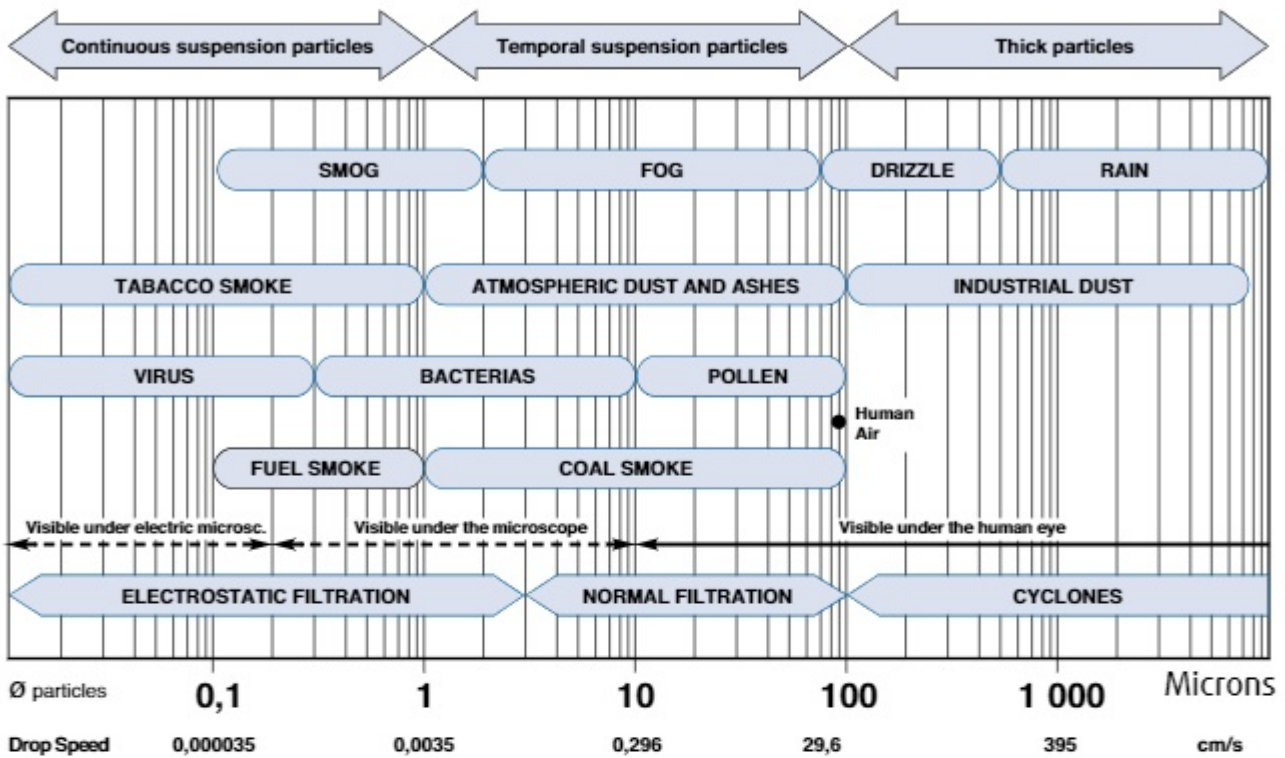

AIR PURITY CONDITIONS IN CLEAN ROOMS

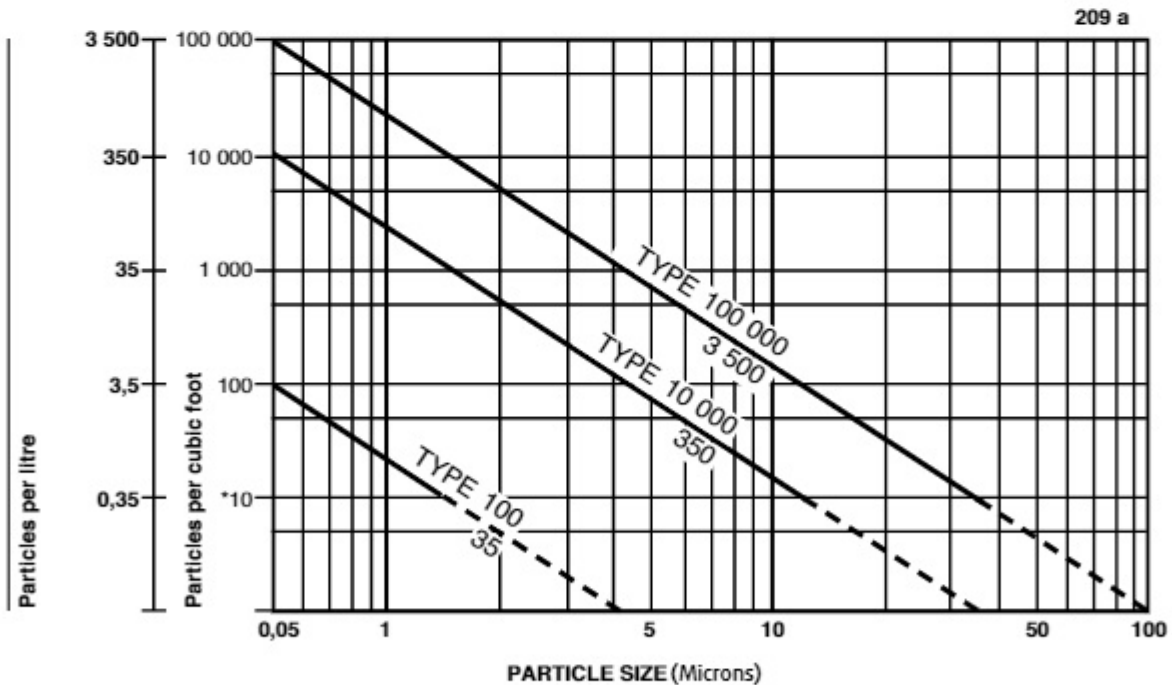

\* Counts below 10 particles per cubic foot (0.35 per litre) are dubious.  
 Example: admissible particles for a Class 10,000 system:  
 10.000 per cubic foot, 0,5 microns.  
 1.200 per cubic foot, 1 micron.  
 70 per cubic foot, 1 micron.





## Delhi Metro Rail Corporation, New Delhi

The Delhi Metro, renowned for its efficiency and extensive network, serves as a lifeline for millions of commuters daily in India's bustling capital. Its significance goes beyond mere transportation, offering a swift and eco-friendly alternative to the city's congested roads. Proper ventilation within the metro system is crucial for several reasons. Firstly, it ensures the comfort and well-being of passengers by maintaining air quality and preventing the buildup of pollutants and heat. Effective ventilation also plays a pivotal role in regulating temperature and humidity levels, creating a pleasant environment even during peak hours.

Moreover, it enhances safety by facilitating smoke dispersal in case of emergencies. In essence, adequate ventilation not only supports the operational efficiency of the Delhi Metro but also guarantees a pleasant and safe travel experience for its passengers. Systemair has been delivering tailored solutions for all phases of DMRC.

We are also suppliers to metro rail projects in other regions of the country like- Kolkata metro, Pune metro, Mumbai metro, Chennai metro, Bengaluru metro, Lucknow metro, RRTS (Meerut line), Agra metro, Jaipur metro,

### Product range supplied:

Tunnel fans, Air distribution products, Dampers, Fire safety products, Ventilation louvers, Air handling units and Ventilations fans

### Designed by Systemair

Designed specifically for fast and easy installation of air handling units, for example the BA plus series.

### HTML5 interface

Intuitive and easy navigation of menus that can be used on a variety of devices including NaviPad, tablets, smartphones or computers. Access to information can be set to three different user levels, depending on competence.

### Connectors for external components

The installation and startup time can be reduced as all connectors for external components on the control unit are clearly marked and grouped together.

### Dedicated BMS system connection

Internal and external communication circuit for bus-based components. Built-in BACnet, Modbus communication makes the control unit well-prepared for integration into SCADA or BMS system.

### Connection to Systemair Connect

Gather all your air handling units in an easy-to-use cloud service for complete overview and accessibility.

### Plug'n'play with BA plus Series

NaviPad comes as standard with Systemair's BA plus Series air handling units.





## Controllers

# Advanced technology made accessible

At Systemair it's all about making things easier for our customers and we believe that advanced technology should be accessible for everyone. We have combined a strong heart with a sharp mind -

### Systemair Controller

Systemair Controller is a complete control solution for air handling units, which allows you to optimize ventilation performance. It makes the advanced technology of Systemair's air handling units easily accessible, unlocking all their potential - while improving the indoor climate for people at home, at work or in public buildings.

Inspired by the advanced simplicity of today's smart-phones, we have developed a logical and intuitive menu structure. It is now easier than ever to navigate and utilize the full functionality of Systemair's air handling units, whether you are a ventilation professional or not creating the perfect indoor climate.

#### CONTROLLER

#### Home button

Gives you a visual indication of the status for each connected air handling unit.

#### Starting page

Important operating data are shown in real time, easy to change a few clicks.

#### Full control

You have access to all operating data in real time. Should an error occur you will immediately be notified by an alarm. Press the alarm icon to view the list of active alarms including the alarm history.

## SYSTEMAIR CONTROLLER

A complete control solution for air handling units, making advanced technology easily accessible - helping you to create the perfect indoor climate.

#### Your benefits at a glance:

- Developed by Systemair, ergonomic and robust design
- Intuitive, user-friendly navigation
- Editable names for alarms, control components and unit name
- System overview of several units via home button
- 7" TFT, 1024x600 pixels capacitive touch display
- Protection class, IP54

## Heat transfer coils

The cooling and heating units are composed in the enclosure described above, which contains the tube-and-fin heat transfer unit, mounted on a special joint cover.



For air cooling processes, units composed of copper pipes and aluminium fins (Cu/Al) are normally used. At the bottom, the cooling section has a aluminium/stainless steel pan for collecting condensation and a small hose to drain the condensation toward the outside. The pan is slightly tilted for easier drainage, in order to prevent the proliferation of harmful bacteria such as Legionella pneumophila.

Direct expansion units are also used for cooling. These units can be equipped with one or two manifolds. For heating processes, the same type of copper/aluminium units used for cooling is normally used. If the air might contain corrosive chemicals, copper tube and fin (Cu/Cu) units should be used to improve the corrosion resistance of the equipment. This type of unit is more expensive than the copper/aluminium unit.

Electrical heating units can also be installed upon request, depending on the customer's needs.

### Copper tube and aluminium fin heating/cooling units

This class of heating/cooling unit is most commonly installed in air handling units and is composed of a coil of copper pipes covered with thin aluminium fins to greatly increase the primary heat transfer surface of the tube, due to the large transfer surface of the fins.

The front air velocity surface ( $A_{fo}$ ) expressed in  $m^2$  is determined by the dimensions (width x height) of the air handling unit internally.

The maximum horizontal length of the finned coil is

determined by the working width of the interior of the air handling unit and expressed in mm. The depth of the heating/cooling unit is composed of a specific number of rows of tubes facing the direction of air flow. The number of rows is calculated according to the air flow conditions at the inlet and outlet of the unit, based on the cooling or heating energy used by the equipment.

The number of rows is defined by a number, followed by the letters "NR".

Based on the above, a unit designated as 28T 6NR 1439A 2.1P 28NC means:

**28** No. of tubes.

**6** No. of rows.

**1439** Length of finned coil, in mm.

**2.1** Pitch of fins, in mm.

**28** No. of circuits

The standardised Air Handling Unit range uses the following heating/cooling units:

This range can be used with any cooling or heating fluid except steam, where the length of the finned coil is slightly lower, since collectors must be mounted on both sides of the unit instead of one side only, as normally done with other fluids. e deformed under these conditions due to excessive expansion of the metal.

## Heat Recovery

### Rotating regenerative air-to-air recovery unit

Specially designed to transfer sensitive (temperature) and latent (humidity) heat from the exhaust air to the supply air.

The supply air stops in one of the halves of the heat recovery unit, while the exhaust air circulates in counterflow through the other half.

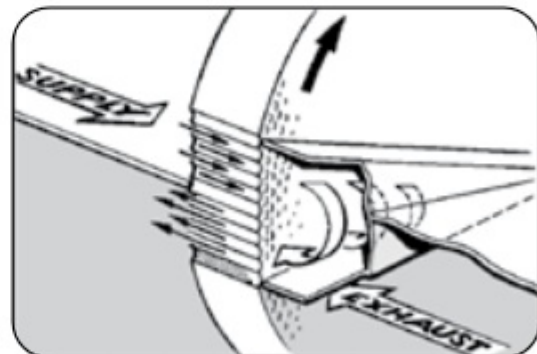

When the impeller turns, the small air flowing channels comprising the impeller are alternately in contact with clean air and with return air, transmitting heat and moisture from one circuit to the other.



### Static recovery unit

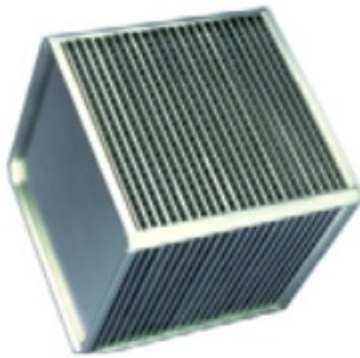

Designed with air-to-air crossflow to transfer sensitive (temperature) heat; in this type of heat recovery unit, the supply air is completely separate from the exhaust air, in order to prevent any type of contamination from one air stream to the other.

- Heat transfer takes place through the plate separating the two streams.
- Two adjacent plates form a small duct for exhaust or supply air.
- The plate-to-plate distance varies, depending on the size and efficiency requirements.

### Run around heat pipe

Designed to transfer sensitive (temperature) heat, using units manufactured with copper pipes and aluminium fins (Cu/Al).

The method is simple and economic, as the return air flows through one of the units, heating the water that circulates inside and is then exhausted.

The outside air flows through the other unit, which heats the air while it cools the circulating water, with the latter heated again in the return circuit, creating a continuous sensitive-heat recovery cycle in the air.

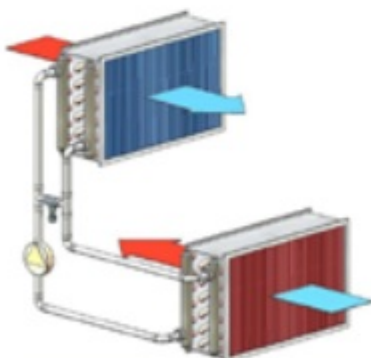

In order to ensure proper system operation in winter, facilities with an extremely low outside air temperature must use glycol water.

Benefits achieved from the installation of any of these

heat recovery systems:

- Reduced heating plant power, minimising equipment sizes in terms of boilers, fuel tank, circulating pumps, heat pipes and heating units.
- Reduced cooling plant size (compressors and condensers or cooling towers), circulating pumps, pipe grid and cooling units. Savings in operating power consumption for heat and cold generation.

Any of the recovery systems mentioned in this section can be installed upon request only, as they are not included in the BA standardised range.

### Fans

This section is composed of a centrifugal fan with an anchor bedplate, drive and electric motor or plug-fan.

The centrifugal fan motor assembly is mounted on Silentbloc bushings and the discharge outlet is joined to the opening in the enclosure by means of a flexible fire retardant synthetic seal.

This allows the unit to run without external transmission of the small vibrations normally caused by fan motor assemblies.

### Centrifugal fan

There are three types of fans that cover all needs: the forward and aerofoil models for low pressures and the backward for medium and high pressures.



*Forward curve fan.*

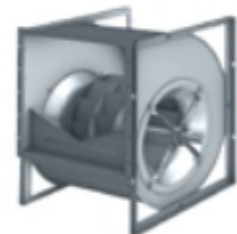

*Backward curve fan.*

Once the fan model is selected, check the respective behaviour curve to obtain the unique characteristics.

Based on two essential factors (air flow and total static pressure), the following is obtained:

- Revolutions per minute
- Efficiency, in %
- Input power at the shaft, in kW;
- Mean sound power level of the octave bands, in dB;
- Air outlet velocity, in m/s;
- Dynamic pressure, in mm w.g.
- Peripheral velocity, in m/s.

### Plug fan

A plug fan supplies air at the fan section outlet with a low and even air speed. In certain situations it can, therefore, be an advantage to position air handling components on the outlet side of the fan.

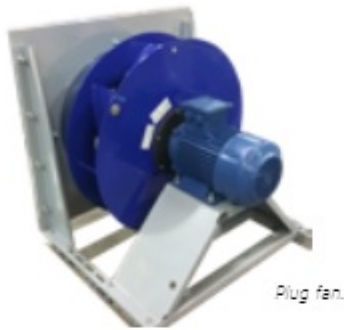

Single inlet plug fan with open outlet into the air handling unit. The fan impeller is fitted directly to the motor shaft. This fan type has low sound power levels in the lower frequencies. Efficiency up to 75%.

The motor is supplied with a 1-speed motor. In order to regulate the fan speed to its actual operating point the motor must be fitted with a frequency converter.

The frequency converter can continuously control the fan speed and airflow. Power consumption can be greatly reduced by operating the fan at lower speed.

Operating temperatures:

Standard design: -10/+40 °C  
 Special design: -30/+60 °C.

All fans are fully balanced both statically and dynamically. The fan and motor are built on a stable base frame that is connected to the unit casing with rubber vibration isolators. These are designed for high levels of vibration absorption.

The fan inlet is flexible connected to the unit casing. This ensures a good vibration absorption.

### EC fan

The EC fan is equipped with a Single Inlet Centrifugal Impeller with High Efficiency Backward curved blades and external rotor EC (Electronically Commutated) motor,

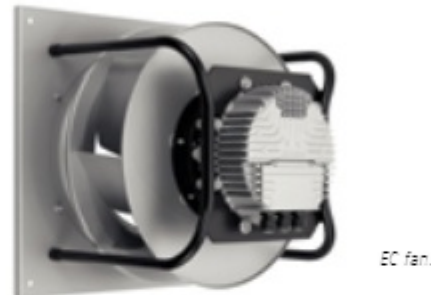

energy optimized for operation without spiral housing for high efficiency and favourable acoustic behaviour. The high efficiency backward curved impeller with rotating diffuser, made of high performance composite material / welded aluminum sheet material, with external rotor motor balanced together statically and dynamically according to DIN ISO 1940 Part 1.

Aerofoil Fans	EFFICIENCY	AREA OF APPLICATION
	Most efficient of the centrifugal fans	General ventilation/air conditioning
	Most efficient operating conditions are achieved with maximum flow of 40-50%	Mainly large systems
	Power is also peaked at the maximum efficiency level	Significant energy savings in large industrial fresh air systems

Backward Curved Fans	Efficiency is slightly lower	General ventilation/air conditioning
	Similar efficiency with Aerofoil fan	Certain industrial applications where air foil fans might be exposed to corrosion and wear

Forward Curved Fans	Fan should not be operated on the right side of maximum pressure	Mainly for low pressure ventilation/air conditioning applications
	Most efficient operating conditions are achieved with maximum flow of 50-60%	
	Lower maximum efficiency than the other centrifugal fans	



The EC fan is capable of being fitted in horizontal or vertical position in the AHU, depending on the application. Inlet cone is provided with a nozzle for volume flow measurement of the fan.

## Silencers

The baffles of the silencer section are constructed of natural galvanized steel sheet, with a peak at the air inlet end to decrease the head loss. The baffles are also filled with a sound-insulating material composed of fibreglass with an appropriate density. This material is also heat-resistant and its outer face is protected against air erosion.

There are two options:

- **PA.** The sound insulation is protected against erosion due to air flow by a flame-retardant protective layer.

This is the most common approach in ventilation and air conditioning systems.

- **PAM.** Similar to PA, but with an additional polyester-film coating (Melinex).

Used for applications with acidic, alkaline or oily gases, as it can be steam-cleaned.

Recommended for hospitals, since bacterial colony formation is not possible.

These two models can be constructed with four lengths of baffle.

## Humidifier

Two different types of air humidifiers can be installed in BA air handling units. In both cases, the units are adiabatic humidifiers.

### Panel humidifier



Composed of a standardised enclosure, including a stainless steel drip pan at the bottom.

The enclosure houses the humidifier panel, which has crosswise corrugated channels to ensure minimum air resistance as well as a large contact surface between the air and water, thereby releasing moisture into the circulating air.

The top of the panel contains a water manifold, to which the water is pumped through the pipework from the drip pan by means of a small submersible electrical pump. Water is distributed vertically downwards by gravity, coating the entire inner panel surface with an extremely fine film. As the air flows by the panel horizontally through the spaces provided, turbulent flow conditions are established, thereby resulting in efficient transfer of heat and moisture.

**Air scrubber**, composed of an enclosure with a large drip pan at the bottom. The tray contains enough water to create steady state conditions in the scrubber system and is equipped with hoses to connect the circulating pump (supplied when requested by the client) and water supply, drain and overflow fittings.

The water travels through a distribution branch with spray nozzles. Two distribution branches may be used to increase the efficiency of the humidifier.

A drop separator with blades designed to hold drops in the air is installed on the air outlet side, ensuring that no drops are carried to other sections.

### Air cooler application

The above example shows that this type of panel may be used as a cooling medium, since its behaviour is typical of an adiabatic cooling or constant enthalpy process.

Based on the above data, when heat dissipation of 200,000 kcal/h is needed in a space where the inside temperature should be maintained at no more than 29°C, it is possible to calculate the air flow that should be introduced and therefore also removed from the local.

The air flow required will be:

$$\frac{200}{(29^{\circ}\text{C} - 24^{\circ}\text{C}) \times 0,3} = 133.333 \text{ m}^3/\text{h}$$

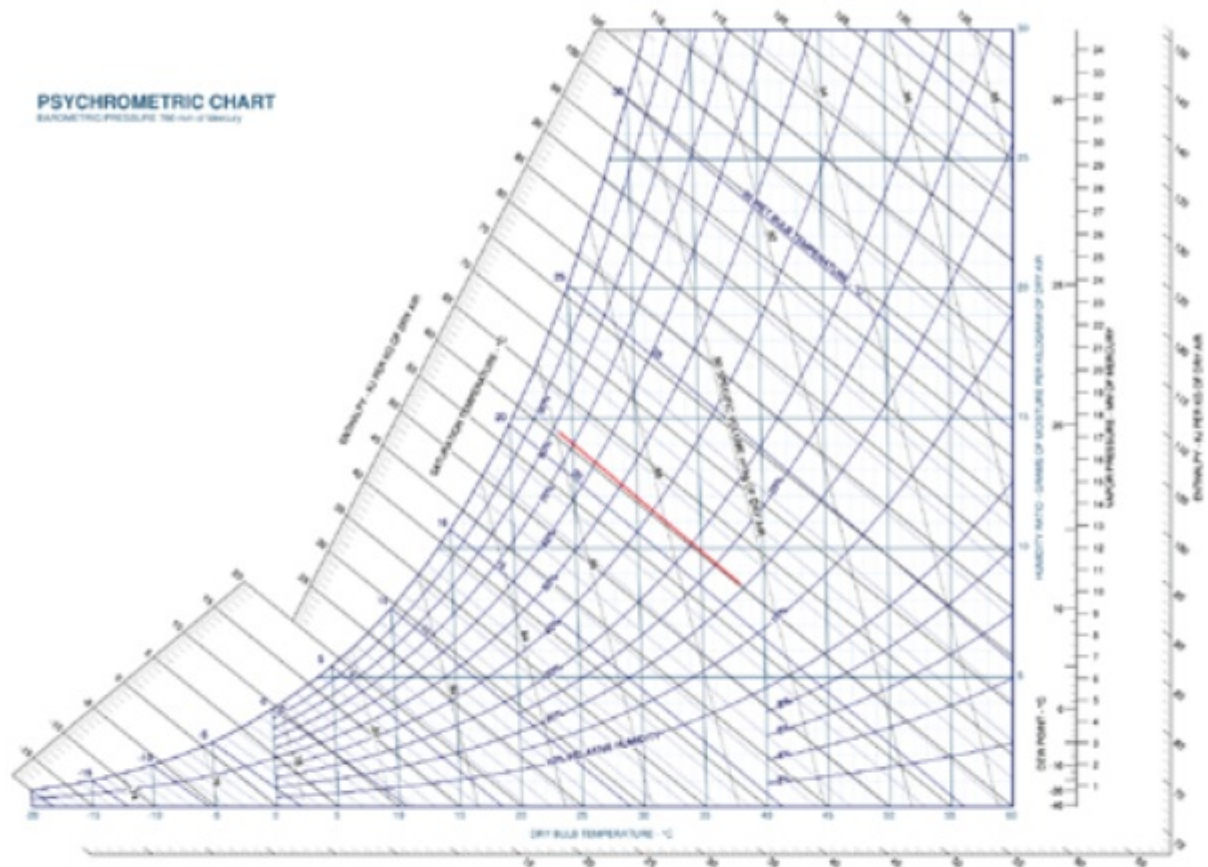

In order to calculate the humidifier's efficiency, use the following formula to determine the saturation efficiency (SE):

$$SE = \frac{T_{se} - T_{ss}}{T_{se} - T_h} \times 100$$

Where:

$T_{se}$  = dry bulb temperature of inlet air.

$T_{ss}$  = dry bulb temperature of outlet air.

$T_h$  = wet-bulb temperature of air.

Based on the psychrometric chart (a diagram is shown on this page), air with inlet conditions of 38° C ( $T_{se}$ ) and 21° C ( $T_h$ ) is converted in the humidifier finding the process at the wet-bulb line of 21° C until reaching an outlet temperature of 24° C ( $T_{ss}$ ).

The saturation efficiency will be:

$$SE = \frac{38 - 24}{38 - 21} \times 100 = 82,3\%$$

This percentage is reasonable, since the maximum level that can be expected from this type of humidifier is 90%, as shown in actual practice.

When this example is applied to a specific case in which an air flow of 30000 m<sup>3</sup>/h, is circulating and the moisture content of the air at the inlet ( $x_e$ ) is 8.6 g/kg and at the output ( $x_s$ ) is 14.4 g/kg, **then the amount of moisture added is:**

$$\frac{30.000 \times 1,2 \times (14,4 - 8,6)}{1.000} = 208,8 \text{ kg of water/ hour}$$



## Control System

BA\* & BA AHU is available with preinstalled, preconfigured & fully integrated control system. It is a user friendly system where functions & parameters can be selected from the inbuilt Human machine interface (HMI) of the controller or through building management system. The operating data, set points, alarms, operating status & time settings are displayed on the controller.

The control system is preloaded with design temperature, relative humidity, pressure drops etc., time settings & control sequence which simplifies field commissioning. The set points can be modified in the field if required.

The control system is capable of performing various function such as

- Temperature control for supply air or room conditions.
- Relative humidity control
- Dew point control
- Constant air volume control for supply air
- Enthalpy control
- Excessive pressure drop alarm
- Heat recovery control
- Run around coil heat exchanger control
- Electric heater control
- Cooling/heating coil water flow control
- Integration of DX coil with outdoor condensing unit
- Fresh/return/bypass/mixing/supply air damper control
- Redundancy control for EC fans
- AHU shut off from external fire signal
- Open protocol (BACnet/Modbus over RS 485/LON) to communicate with all Building Management Systems.
- Possibility to access the control system remotely through WEB
- Possibility to add additional control/alarm points as per customer's need
- Logging of various parameters
- VAV, VRF, Inline fan and Humidifier Integration
- Possibility of Air Quality Control



## Selection Tools

We have developed this overview to make it easier for you to get an idea of which product best suits your specific needs. More detailed analysis or planning usually requires additional information, which is where the following tools come in.



### Software Program

Selection Program named **Systemair BAHU is tested & certified by EUROVENT.**

- customers can choose various construction/ manufacturing options viz. sheet thickness, insulating materials, fin material, manifolds material etc.
- customers can design unit sections based on required application viz. mixing section, filtration level, recovery section, cooling / heating section & choose fan/ motor of their choice.
- it actually lets customers decide sectional possibilities in order to decide the dimensions of space required to place a unit.
- Divide the equipment into modules, in accordance with the project requirements;
- Obtain all technical information for the equipment selected, including the curves for the selected fan and its operating point;
- Estimate the cost of the equipment.

The Selection Program is user-friendly and highly intuitive.



### Product catalogue and specification data

More detailed technical information, sufficient to carry out complete planning, is available in separate catalogues and specification data. These describe all incorporated functions, available accessories, and additional technical data.



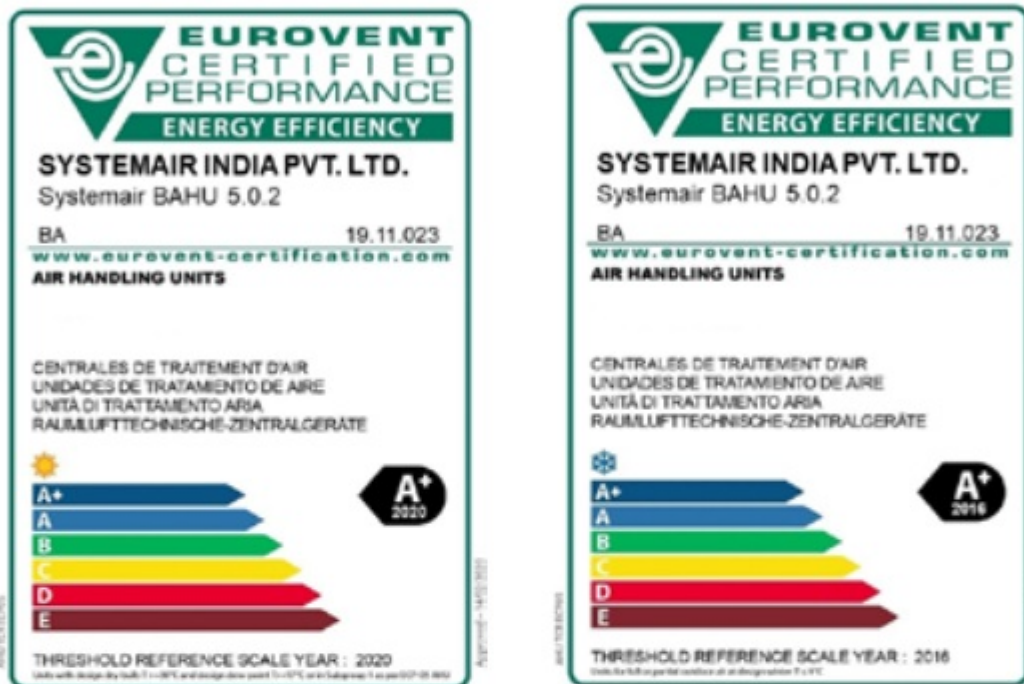

## Energy Efficiency Class

The Energy Efficiency Standards are a set of procedures and regulations that prescribe the energy performance of manufactured products. The Air Handling Units manufactured by Systemair are certified by a globally trusted leading European certification agency, Eurovent Certita Certification. The sticker below can be found on our units as a mark of authentic certification.



### Label Indication (Summer/ Winter)

The Energy Efficiency Class for Summer and Winter Applications may be different and are indicated separately.

Energy Efficiency Label	Label Indication
Energy Efficiency Class for Summer Applications	
Energy Efficiency Class for Winter Applications	

### Energy Class Indication

There are 6 energy classes A+, A, B, C, D and E according to ECC. The energy class is determined on the basis of parameters like power consumed by the fan motor, outdoor air temperature, pressure drop across the heat recovery systems, reference velocity, etc.

## Resulting Class according to EN 1886 : 2007

	BA+	BA
CASING STRENGTH	D1	D1
CASING AIR LEAKAGE	L1	L1
THERMAL BRIDGING FACTOR	TB2	TB2
THERMAL TRANSMITTANCE	T2	T3
FILTER BY PASS LEAKAGE	F9	F9

## Performance Characteristics tested to EN 13053 standard for

AIR FLOW - STATIC PRESSURE DATA - POWER CONSUMPTION
HEAT RECOVERY
COOLING DUTY
HEATING DUTY
AIR - SIDE & WATER - SIDE PRESSURE DROP

## GreenPro Ecolabel

The Type - 1 Ecolabel enables the end users in the building sector and manufacturing industries to choose right products, materials and technologies for reducing the environment impacts during the construction, operation and maintenance of their buildings and factories. The unique 8-point credit system evaluates the manufacturer's prowess and sincerity towards sustainability.

SUSTAINABILITY MEASURES IMPLEMENTED AS PART OF ENVIRONMENT MANAGEMENT SYSTEM
PRODUCT PERFORMANCE
RAW MATERIALS
MANUFACTURING PROCESSES
WASTE MANAGEMENT
LIFE CYCLE APPROACH
PRODUCT STEWARDSHIP
RECOGNITIONS AND INNOVATIVE MEASURES





## Amazon Warehouse, Delhi

Amazon's warehouse in Delhi showcases a robust infrastructure designed to handle large volumes of inventory and facilitate efficient order fulfillment. The facility features expansive storage areas, advanced robotics for inventory management, and streamlined logistics operations. Ventilation systems are integral to maintaining optimal air quality and temperature control within the warehouse, ensuring a comfortable and safe working environment for employees. These systems help regulate airflow, maintain humidity levels, and prevent the buildup of pollutants, thereby safeguarding the integrity of stored goods and enhancing overall operational efficiency.

**Product range supplied:**  
Air Handling Units



## IIT, Kharagpur, India

Indian Institute of Technology (IIT) Kharagpur, one of India's premier technical institutions, boasts a sprawling campus with a diverse range of buildings dedicated to education, research, and residential purposes. The campus encompasses academic buildings, laboratories, administrative offices, student hostels, faculty residences, and recreational facilities spread across a vast area. The need for proper ventilation systems in such a complex infrastructure is crucial for supporting comfort, health, sustainability, and safety across its diverse campus facilities.

**Product range supplied:**  
Air Handling Units, Fans





Reliance Life Sciences, Mumbai  
Image used for representation purpose only

## Reliance Life Sciences, Nashik

Reliance Life Sciences is investing in a new plant and looking to enter new segments. The biotechnology player will be the next big thing from the Reliance stable (Reliance Life Sciences is part of the Promoter Group of Reliance Industries Limited.)

Reliance Life Sciences is a research-driven organization in bio-therapeutics (plasma proteins, biosimilar and novel proteins), pharmaceuticals (later-generation, oncology generics), clinical research services, regenerative medicine (stem cells therapies) and molecular medicine.

Reliance Life Sciences is a fully-integrated life sciences industry player with in-house capabilities in research, pre-clinical and clinical development, process development, quality management, commercial-scale manufacturing and marketing.

**Product range supplied:**  
Air Handling Units



## Waaree Solar, Mumbai

Waaree Energies Ltd. is the flagship company of Waaree Group, founded in 1989 with headquarters in Mumbai, India. Waaree Energy is today one of the largest vertically integrated energy companies. It has India's largest Solar panel manufacturing capacity of 12GW at its plants in Chikhli, Surat and is a top player in EPC Services, Project Development, Solar Rooftop Solutions, Solar Inverter, and Solar Water Pumps. It is also an Independent Power Producer. Waaree has a presence in over 388 locations nationally and 20 countries internationally.

**Product range supplied:**

Air Handling Units, Air distribution products





## IKEA, Mumbai, India

The IKEA stores in Navi Mumbai and Mumbai stand as a sprawling testament to the brand's commitment to offering a comprehensive shopping experience. The stores are marvels of modern retail infrastructure, meticulously designed to enhance customer experience and operational efficiency. The stores are equipped with modern HVAC (Heating, Ventilation, and Air Conditioning) systems that ensure optimal indoor air quality and temperature regulation throughout the expansive spaces. Efficient air handling units are strategically placed to circulate fresh air and maintain consistent airflow, preventing any stagnant zones and ensuring a pleasant shopping atmosphere for visitors. In Navi Mumbai and Mumbai, where environmental factors like humidity and heat can vary significantly, IKEA's infrastructure is designed to adapt and maintain comfort levels year-round.

**Product range supplied:**  
Air Handling Units, Air distribution products

## BA unit performance certificate



**CERTIFICATE**  
**N° 19.11.023**



**Air Handling Unit / Centrales de traitement d'air**

**Range Name / Nom de Gamme :**  
**BA**

Granted on November 20, 2019 - Date 1ère admission 20 novembre 2019

This document is valid at the date of issue - Check the current validity on:  
Document valable à la date d'émission - Vérifier la validité en cours sur :  
[www.eurovent-certification.com](http://www.eurovent-certification.com)

**Participant/Titulaire**

**SYSTEMAIR INDIA PVT. LTD.**  
Plot N°3 , Sector 31 ECOTECH-I Kasna - Site IV  
201 308 GREATER NOIDA, India

This product performance certificate is issued by Eurovent Certita Certification according to the certification rules:

**ECP AHU - « Air Handling Unit » in force at established date.**

Pursuant to the decision notified by Eurovent Certita Certification, the right to use the mark ECP shall be granted to the beneficiary company for the above Range in the conditions defined by the certification program mentioned.

Unless withdrawn or suspended, this certificate remains valid as long as the requirements for the certification program framework are met. The validity of the certificate is to be verified on [www.eurovent-certification.com](http://www.eurovent-certification.com)

**THIS CERTIFICATE HAS BEEN ISSUED ON 29/05/2024**  
**THIS CERTIFICATE IS VALID UNTIL 31/10/2024**

Ce certificat de performance produit est délivré par Eurovent Certita Certification dans les conditions fixées par le référentiel :

**ECP AHU - « Centrales de traitement d'air » en vigueur à date d'édition.**

En vertu de la décision notifiée par Eurovent Certita Certification, le droit d'usage de la marque ECP, est accordé à la société qui en est bénéficiaire pour la gamme visée ci-dessus, dans les conditions définies par le programme de certification mentionné.

Sauf retrait ou suspension, ce certificat demeure valide tant que les conditions du référentiel du programme de certification sont respectées. La validité du certificat est à vérifier sur le site Internet [www.eurovent-certification.com](http://www.eurovent-certification.com)

**CE CERTIFICAT A ÉTÉ EMIS LE 29/05/2024**  
**CE CERTIFICAT EST VALIDE JUSQU'AU 31/10/2024**

Paris, 29 mai 2024



Organisme accrédité n° 5-0517 Certification Produits et Services selon la norme NF EN ISO/IEC 17065:2012  
Portée disponible sur [www.cofrac.fr](http://www.cofrac.fr)  
Accreditation #5-0517 Products and Services Certification according to NF EN ISO/IEC 17065:2012 --  
Scope available on [www.cofrac.fr](http://www.cofrac.fr)  
COFRAC est signataire des accords MLA d'EA.  
COFRAC is signatory of EA MLA.  
List of EA members is available on [www.eurovent-certification.org/ea-members](http://www.eurovent-certification.org/ea-members)

**MANAGING BOARD MEMBER / MEMBRE DIRECTOIRE**

1/2





**CERTIFICATE**  
**N° 19.11.023**



## Appendix / Annexe

Granted on November 20, 2019 - Date 1ère admission 20 novembre 2019

This document is valid at the date of issue - Check the current validity on:

Document valable à la date d'émission - Vérifier la validité en cours sur :

[www.eurovent-certification.com](http://www.eurovent-certification.com)

List of certified products and characteristics is displayed on:

La liste des références et caractéristiques certifiées est disponible sur le site :

[www.eurovent-certification.com](http://www.eurovent-certification.com)

This product performance certificate is valid for the following trade names:

Ce certificat de performance produit est valide pour les marques commerciales suivantes:

Trade Name / Marque Commerciale

SYSTEMAIR

This product performance certificate is valid for the following manufacturing places:

Ce certificat de performance produit est valide pour les sites de production suivants:

Manufacturing Place / Site de Production

GREATER NOIDA, India  
Hyderabad, India

This product performance certificate is valid for the following software:

Ce certificat de performance produit est valide pour les logiciels de sélection suivants:

Software / Logiciel de sélection

SYSTEMAIR BAHU 5.0.7

2/2

## Quality Management ISO certificate



# MANAGEMENT SYSTEM CERTIFICATE

Certificate no.:  
176390-2015-AQ-IND-RvA

Initial certification date:  
12 April 2006

Valid:  
12 April 2024 – 11 April 2027

This is to certify that the management system of

### **Systemair India Private Limited**

Unit 1 (Head Office): Plot No. 03, Ecotech-I, Sector-31, Site IV, Kasna, Greater Noida - 201308, Uttar Pradesh, India

and the sites as mentioned in the appendix accompanying this certificate

has been found to conform to the Quality Management System standard:

**ISO 9001:2015**

This certificate is valid for the following scope:

**Design, development, manufacture, marketing, supply and service of HVAC products**

Place and date:  
Barendrecht, 12 April 2024

For the issuing office:  
DNV - Business Assurance  
Zwoiseweg 1, 2994 LB Barendrecht,  
Netherlands



Eric Koek  
Management Representative

Lack of fulfillment of conditions as set out in the Certification Agreement may render this Certificate invalid.

ACCREDITED UNIT: DNV Business Assurance B.V., Zwoiseweg 1, 2994 LB, Barendrecht, Netherlands - TEL: +31(0)102822688, www.dnv.com/assurance





Certificate no.: 176390-2015-AQ-IND-RvA  
Place and date: Barendrecht, 12 April 2024

## Appendix to Certificate

### Systemair India Private Limited

Locations included in the certification are as follows:

Site Name	Site Address	Site Scope
Systemair India Private Limited	Unit 1 (Head Office): Plot No. 03, Ecotech-I, Sector-31, Site IV, Kasma, Greater Noida - 201308, Uttar Pradesh, India	Design, development, manufacture, marketing, supply and service of HVAC products
Systemair India Private Limited	Unit 2: Plot No. B-3/1, Ecotech-I Extension, Greater Noida - 201308, Uttar Pradesh, India	Manufacture and supply of HVAC products
Systemair India Private Limited	Unit 3: 8-84/14/11, Opp. Sai Geetha Ashram, Devaryamzal, Medchal District, Hyderabad - 500078, Telangana, India	Manufacture, marketing, supply and service of HVAC products



Lack of fulfillment of conditions as set out in the Certification Agreement may render this Certificate invalid.

ACCREDITED UNIT: DNV Business Assurance B.V., Zwolterweg 1, 2994 LB, Barendrecht, Netherlands - TEL: +31(0)102922685 - www.dnv.com/assurance



# MANAGEMENT SYSTEM CERTIFICATE

Certificate no.:  
C706217

Initial certification date:  
01 October 2020

Valid:  
26 October 2023 – 30 September 2026

This is to certify that the management system of

## **Systemair India Private Limited**

Unit 1 (Head Office): Plot No. 03, Ecotech-I, Sector-31, Site IV, Kasna, Greater Noida - 201308, Uttar Pradesh, India

and the sites as mentioned in the appendix accompanying this certificate

has been found to conform to the Environmental Management System standard:

### **ISO 14001:2015**

This certificate is valid for the following scope:

**Design, development, manufacture, marketing and service of HVAC products**

Place and date:  
Barendrecht, 02 July 2024

For the issuing office:  
DNV - Business Assurance  
Zwolsseweg 1, 2994 LB Barendrecht,  
Netherlands



Eric Koek  
Management Representative

Lack of fulfillment of conditions as set out in the Certification Agreement may render this Certificate invalid.

ACCREDITED UNIT: DNV Business Assurance B.V., Zwolsseweg 1, 2994 LB, Barendrecht, Netherlands - TEL: +31(0)102922688 - www.dnv.com/assurance





Certificate no.: C706217  
Place and date: Barendrecht, 02 July 2024

## Appendix to Certificate

### Systemair India Private Limited

Locations included in the certification are as follows:

Site Name	Site Address	Site Scope
Systemair India Private Limited	Unit 1 (Head Office): Plot No. 03, Ecotech-I, Sector-31, Site IV, Kasna, Greater Noida - 201308, Uttar Pradesh, India	Design, development, manufacture, marketing and service of HVAC products
Systemair India Private Limited	Unit 2: Plot No. B-3/1, Ecotech-I Extension, Greater Noida - 201308, Uttar Pradesh, India	Manufacture of HVAC products
Systemair India Private Limited	Unit 3: 8-84/14/11, Opp. Sai Geetha Ashram, Devaryamzal, Medchal District, Hyderabad - 500078, Telangana, India	Manufacture, marketing and service of HVAC products



Lack of fulfillment of conditions as set out in the Certification Agreement may render this Certificate invalid.

ACCREDITED UNIT: DNV Business Assurance B.V., Zwolseweg 1, 2994 LB, Barendrecht, Netherlands - TEL: +31(0)102922689 - www.dnv.com/assurance

Page 2 of 2

# Offices across India

## NORTH & EXPORT

### **Noida**

B-39, 3rd Floor, Sector 63, Noida, U.P. 201301

Tel: +91 1204763100

## EAST

### **Kolkata**

92/2A Bidhan Nagar Road, Kolkata, West Bengal -700067

Tel: +91 9830420473

## WEST

### **Mumbai**

804, 8th floor Ruby Crescent Business Boulevard Chakravarty

Ashok Road, Ashok Nagar Kandivali ( East) Mumbai -400101

Tel: +91 8108124863

### **Pune**

Office No 7B , B wing Manorama Apartments

Lane no 7, Prabhat Road, Pune-411004

Tel: +91 9823987810

### **Ahmedabad**

A-505, Prahlad Nagar Trade Center, Times of India Press road,

Vejalpur, Ahmedabad 380015, India

Tel: +91 9920962642

## SOUTH

### **Hyderabad**

Plot No. 8-84/14/11; Opp. Sai Geetha Ashram;

Devaryamzal, Medchal Dist, Hyderabad 500078

Tel: +91 7674889007

### **Bengaluru**

#3, 2ND Floor, Survey No.18, PDS Tower,

Sanjeevini Nagar, Kodigehalli Main Road,

Sahakar Nagar Post, Bangalore - 560092.

Tel: +91 9686454434

### **Cochin**

2nd Floor, Poovathankavil Gardens, Subhash Chandra Bose Road,

Vytilla, Cochin, Kerala - 682019

Tel: +91 8688824419

### **Chennai**

No 3020, Old Y Block, 4<sup>th</sup> Street, 13<sup>th</sup> main road,

Anna nagar, Chennai 600040

Tel: +91 6366430422

## **Systemair India**

(Head office & Manufacturing Plant)

LEED Platinum Campus

Plot No.03, ECOTECH I, Sector-31,

Kasna, Greater Noida,

U.P - 201308.

**Unit II** - Plot No.-B-3/1, Eco-

tech-1 Extension

Greater Noida, U.P-201308

Tel: +91 120 4763 100

Fax: +91 120 4763 101

[mailbox@systemair.in](mailto:mailbox@systemair.in)

[www.systemair.com/in](http://www.systemair.com/in)

