



Powerful and efficient fan heater with EC motor

Panther FC 20-30 is a range of powerful and quiet fan heaters intended for heating and drying in industrial premises and other large buildings. They are equipped with EC motor ensuring stepless airflow control. Together with the FC control system, the fan heater can provide fully automatic room heating adaptable to each unique area of use.

Quiet and effective

Panther FC 20-30 is a quiet and efficient fan heater for stationary use contributing to a better indoor climate for large-sized premises. This fan heater provides fast and efficient heating.

Intelligent control system

Fan heater Panther FC is prepared for, and must be completed with, your choice of FC control system. FC allows you to optimize energy savings and comfort with minimal effort. In addition to fully self-regulating heating, smart automatic functions enable easy set-up and operation.

Lower sound level and energy consumption

The fan heater is equipped with an EC motor which is up to 50% more energy efficient than a traditional AC motor. The stepless fan control gives optimal settings and lower sound level.



Product specifications

- Automatically adjusted fan speed, depending on heat demand, gives quiet operation.
- Supplied with a versatile wall bracket that makes it possible to direct the airflow where it's needed, downwards and to the side.
- Heat output 20-30 kW.
- Option for heat blocking to avoid unnecessary heating.
- The zone feature allows you to create different zones for different conditions.
- Can be controlled with the app Frico Control or via BMS.
- Equipped with EC fans with stepless fan control for optimal settings and sound level.



Panther FC 20-30 (IP44)

Item no	Type	Output steps [kW]	Airflow [m³/h]	Sound power*1 [dB(A)]	Sound pressure*2 [dB(A)]	Δt *3 [°C]	Motor [W]	Voltage [V]	Amperage [A]	WxHxD [mm]	Weight [kg]
334031	PNF20	0/10/20	2250/2800	78	51/62	27/21	150	400V3N~	29,5	478x576x545	25
334033	PNF30	0/10/20/30	2250/2800	78	51/62	32/40	150	400V3N~	43,9	478x576x545	28

*1) Sound power (L_{WA}) measurements according to ISO 27327-2: 2014, Installation type E.

*2) Sound pressure (L_{pA}). Conditions: Distance to the unit 3 metres. Directional factor: 2. Equivalent absorption area: 200 m². At lowest/highest airflow.

*3) Δt = temperature rise of passing air at maximum heat output and lowest/highest airflow.

Approved for 380V/3ph/60Hz. Product performance for 380V/3ph/60Hz will differ from stated data.

Manufactured in Sweden with a corrosion proof housing made of hot zinc-plate and powder coated steel panels. Colour: white, RAL 9016.

Air throw

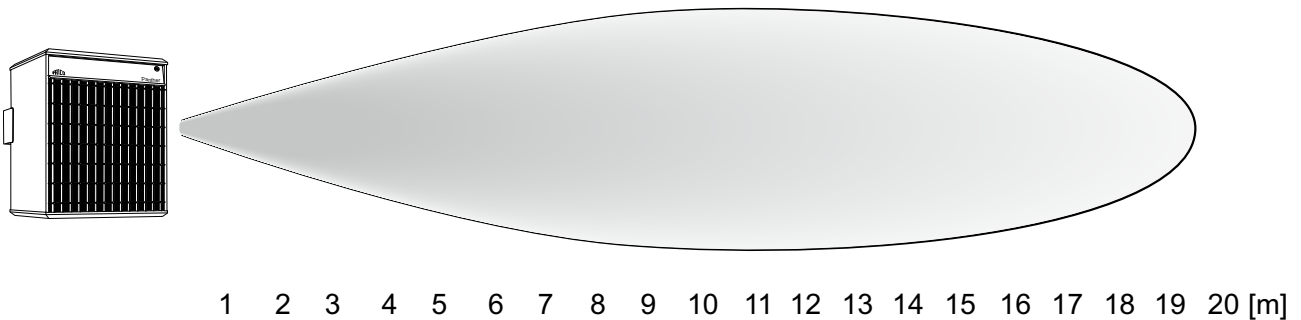

Dimensions

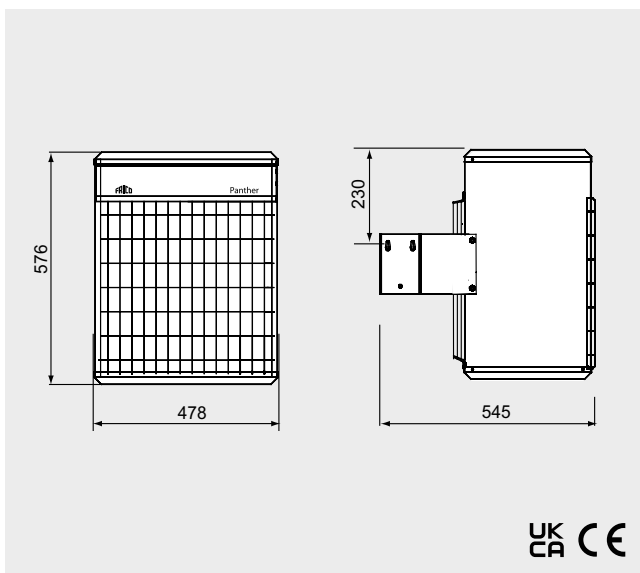

Mounting and connection

Mounting

The Panther fan heater is mounted on the wall with the supplied bracket. The bracket allows the fan heater to be angled downwards and to the side (30° left or right).

Connection

The Panther fan heater is intended for permanent installation. The electrical connection is made on the back of the unit.

Panther FC is prepared for FC control system, available in several packages for different requirements. The FC packages are ordered separately. The fan heater has an integrated PC board which is connected to the selected external control system FC. Communication and sensor cables are connected to the PC board via grommets on the back of the unit.

For wiring diagrams and other technical information, please see the manual and www.frico.net.

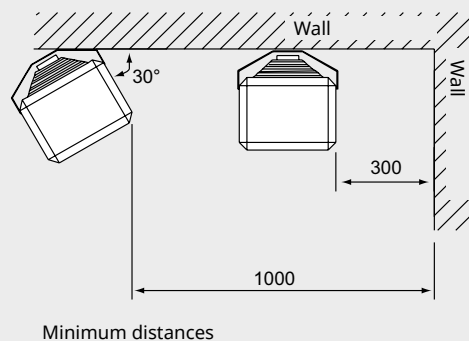
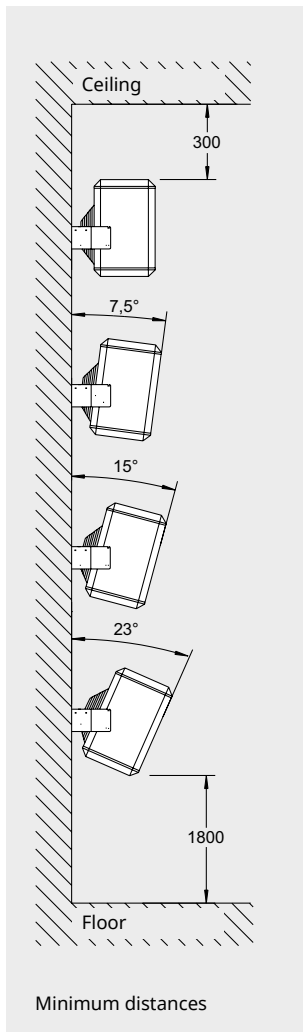

Accessories



PLR30, air director

The air director directs the airflow vertically. PLR is snapped on the front of the heater. Turning angle 0-35°.

Item number	Type	Description	Dimensions
10275	PLR30	Air director for PNF20 - PNF30	415x445x600 mm

This fan heater comes with an integrated PC-board and is supplemented with the intelligent control system FC of your choice, working together to create many smart and energy saving features. There are four different packages to choose from, depending on your requirements.

FC Direct

Entry level

- Automatic fan speed control
- Calendar function
- Built-in temperature sensor
- Outlet temperature limit

FC Smart

FC Direct +

- Control via app (Bluetooth)
- Wireless sensors possible
- Adjustable calendar function
- Away, Boost and Presence function
- Zone possibility

FC Pro

FC Direct + FC Smart +

- Automatic heat blocking

FC Building - BMS

FC Direct +

- 0-10V, potential free contact or Modbus
 - Automatic heat blocking*
 - Heat and fan settings
 - Alarm indication
 - Read values
- * Requires outdoor temp signal*



FC Direct

Entry level control system for a great start. The fan speed is automatically adjusted in auto-mode, achieving the right amount of heat with the lowest possible speed and sound level. With the calendar function, you can choose periods of comfort and reduced mode. It is possible to limit the outlet temperature. The control panel has a built-in temperature sensor, which is used for control when external sensors are not used.



FC Smart

Second level control system for full freedom. FC Smart comes with all features from FC Direct plus additional energy saving features and the possibility of app control (Bluetooth). The app gives you access to all functions in the system, allowing you to set it up exactly the way you want it. It also enables you to create different zones with different settings in a larger system. Choose between several modes for heating only when needed, such as Away, Boost and Presence. The app FRICO CONTROL is available for both iOS and Android.



FC Pro

Third level control system for maximum savings. FC Pro comes with all features from FC Direct and FC Smart plus additional automatic energy saving features. The heat blocking function prevents unnecessary heating, using the wireless outdoor temperature sensor.



FC Building - BMS system

Comprehensive control system for buildings, with the option to control via 0-10V, potential free contact (e.g. a relay) and/or Modbus RTU (RS485). FC Building enables you to receive product information status and alarms. Modbus allows for full use of all the energy saving features within the control system.

Item number	Type	Description
74688	FCDF	FC Direct, first level control system
74689	FCSF	FC Smart, second level control system
74690	FCPF	FC Pro, third level control system
74691	FCBF	FC Building - BMS system

FC Control system helps to create many smart and energy saving features. In addition to our four packages, components can be added to expand and customize the system. With the app levels (FC Smart and FC Pro) it is also possible to create and control different zones. Each added zone needs to be equipped with one FC Direct and can be designed to fit its specific needs by adding different accessories. Air curtains and fan heaters with FC can be installed in separate zones in the same system.



FC Direct, control kit

Control panel for fan and heat and 5 m communication cable. Used for additional zones with FC Smart and FC Pro. IP44.



FCRTX, external room temperature sensor

For reading of the room temperature on another location than that of the control panel, incl. 10 m sensor cable. IP20.



FCOTX, outdoor temperature sensor

Reading the outdoor temperature, incl. 10 m sensor cable. Enables heat blocking. IP44.



FCLAP, local access point

Local access point for extra wireless sensors (when operating more than 8 sensors) and extended range for wireless sensors or app control (Bluetooth), incl. 10 m communication cable. IP44.



FCSC/FCBC, cable

FCSC Sensor cable available in 10 or 25 m for extra length. FCBC Communication cable for additional products within the same zone, available in 5, 10 or 25 m.



FCTXRF, indoor/outdoor wireless sensor

Indoor/outdoor wireless sensor with same features as FCRTX and FCOTX. The set up as outdoor or indoor sensor is made by a switch inside the sensor. Range up to 50 m. Battery life: 3-5 years (2xAAA). IP44.

FC Direct

Content

- FCCF control panel
- FCBC05

FC Smart

Content

- FCCF control panel
- FCBC05
- FCLAP

FC Pro

Content

- FCCF control panel
- FCBC05
- FCLAP
- FCTXRF

FC Building - BMS

Content

- FCCF control panel
- FCBC10
- FCBAP building access point

Item number	Type	Description	Dimensions
74684	FCDF	FC Direct, first level control system	89x89x26 mm (FCCF)
74694	FCRTX	External room temperature sensor	39x39x23 mm
74695	FCOTX	Outdoor temperature sensor	39x39x23 mm
74699	FCLAP	Local access point for extra wireless sensors and extended range	89x89x26 mm
74718	FCBC05	Extra communication cable, 5 m	5 m
74719	FCBC10	Extra communication cable, 10 m	10 m
74720	FCBC25	Extra communication cable, 25 m	25 m
74721	FCSC10	Extra sensor cable, 10 m	10 m
74722	FCSC25	Extra sensor cable, 25 m	25 m
74703	FCTXRF	Indoor/outdoor wireless sensor (for FC Smart, FC Pro)	89x89x26 mm