

SYSLOOP

Water source heat pump
Models SL15 to SL30

Refrigerant R410A



1.93 to 3.68kW



1.51 to 2.90kW



435 to 525 m³/h

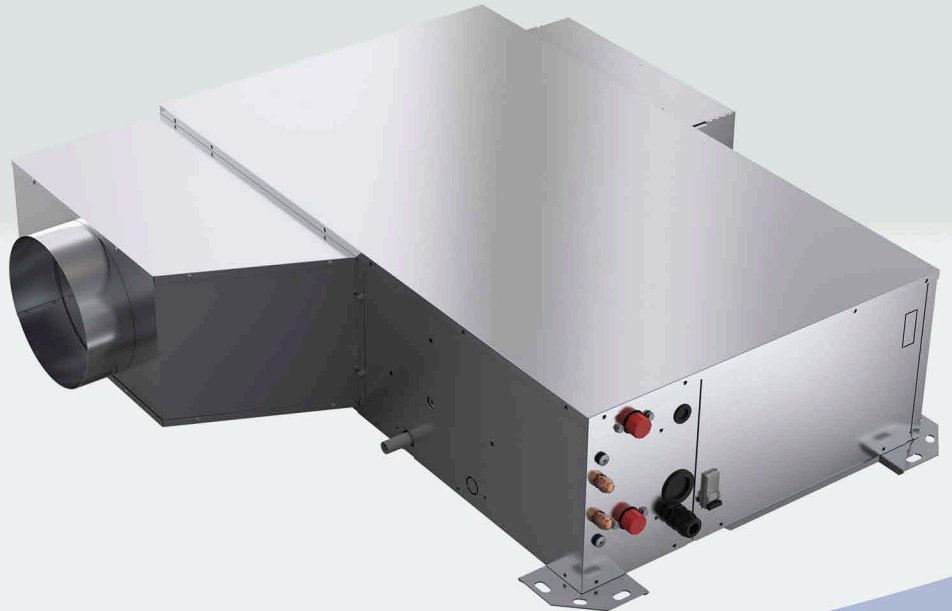
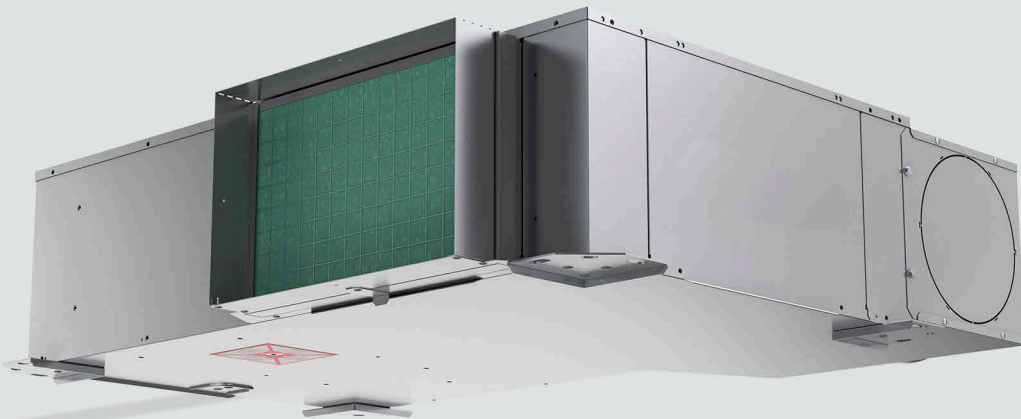

Description of Units

- **1 optimally compact casing size, 3 models** with a nominal cooling capacity ranging from **1.5 to 2.9 kW**.
- **Reduced overall dimensions with maximum height of 240 mm.**
- High efficiency horizontal units with **high COP** values.
- Easy access to the compressor, fan and electronic control box, through **wide removable panels**.
- **In-line, L or U air blowing.**
- Fan with low consumption **EC motor** as standard.
- The water/refrigerant heat exchanger is of copper / stainless steel **coaxial** type for an increased efficiency and **wider operating range**.
- Condensate drain pan **without siphon and with anti-corrosion treatment** by oven-baked epoxy paint.
- Plug & Play conception in order to ease installation and start-up :
 - ✔ Power supply indicating lights on lower side,
 - ✔ Unit status indicating lights on lower side,
 - ✔ Transport unclamping of compressor without opening the unit,
 - ✔ Multi-position hanging possibility,
 - ✔ External HP and LP pressure tap.
- Capillary expansion device.
- Autonomous control by **Siemens POL423 controller. The POL 822 user remote control** includes a digital display and key control buttons.
- **The optional POL871 removable display** enables the configuration of a master/slaves network of **15 units**.

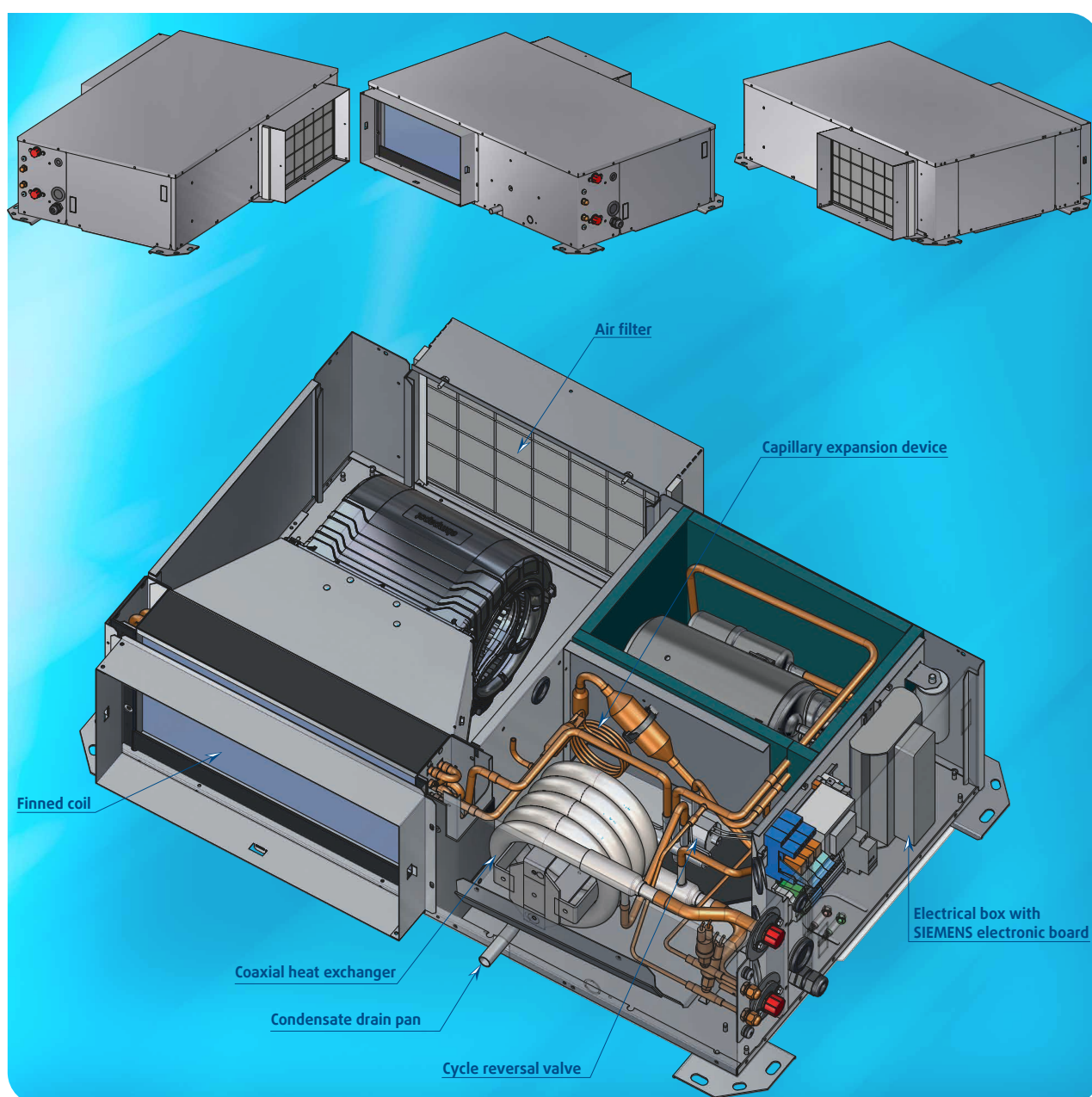

Technical Specifications

Introduction

The new generation of **SYSLOOP model reversible water source heat pumps** is the fruit of our considerable product experience and our awareness of the market, all combined with a technology based on the energy efficiency of machines, in order to provide for **units with the highest performance in terms of COP**.

Range

The **SYSLOOP horizontal units** are designed for installation in specifically designed false ceilings or in technical rooms, and are available with a range of nominal cooling capacity ratings of between 1.5 and 2.9 kW, with **3 models** using a single casing size.

Operating range

To enable a much wider operating range and operation using a water source in an application with a dry cooler, the standard **SYSLOOP** units are designed to operate in a **water source temperature range of between 11 and 45 °C**.

Casing design

The casing is made of galvanised sheet steel. To facilitate access to the main components, wide removable panels provide access to the compressor, the fan and the electronic control box.

The condensate drain pan has anti-corrosion treatment consisting of oven-baked epoxy paint.

Compressor section is thermally and acoustically insulated with 15 mm thick Isofeutre. Ventilation section is classified M1.

Units are in conformity with "ERP Building Receiving the Public" fire standard.

Filtration

All units can be equipped with a basic filter or G3 M1 disposable filter, 23 mm thick. The filter can be removed/installed from the side of the units or from the bottom without having to remove the optional return duct.

Hydraulic connections

The water source outlet and return connectors are located on the outside of the unit, on the compressor compartment side. They are male gas type tapped fittings, internal diameter 1/2".

Evacuation of condensates is realized with no need of siphon by positive pressure and gravitational flow.

The condensate evacuation connection is with an external diameter of 16 mm.

Electrical box

The electrical box is located on the hydraulic service side.

A wide access panel is provided to facilitate the maintenance operations.

Units are equipped with power on and fault indicating lights located on the lower side of the unit, allowing quick checking of the power on presence and status of the units without intervention.

The electrical power supply is 230V/1Ph/50Hz.

The compressors are factory equipped with an internal thermal protection with an automatic reset function.

Refrigerant circuit

The refrigerant circuit comprises a rotary type hermetic compressor, a cycle reversal valve, a water/refrigerant heat exchanger, a liquid receiver, a capillary expansion device and a finned coil.

The refrigerant circuit also comprises an HP pressure switch and an LP pressure switch both with automatic reset function. Two Schrader valves (HP & LP) located on the service side are available for pressure measurement on the refrigerant circuit.

The compressor, mounted on spring anti-vibration mounts, is integrated in a compartment coated with a reinforced acoustic insulation, which reduce noises. Its clamping, necessary during transportation, can be released from the outside of the unit.

The water/refrigerant heat exchanger is of copper / stainless steel coaxial type for an increased efficiency.

The anti-freeze safety of the heat exchanger is provided by a water pipe sensor located on the water outlet of the unit.

Optional water flow protection controlled by the electronic board of the unit is available.

Maximum service pressure is 40bar. The heat exchangers are particularly well adapted to the operation of reversible heat pumps which have high thermal transfer rates for a low water flow-rate.

The air/refrigerant coil is made up of aluminium fins which are mechanically crimped onto copper tubes. The geometry of the coil and of the fin profile have been carefully designed to provide maximum efficiency in the operation of the units.

The cycle reversal valve is designed to be normally energised in heating mode. This logic enables the heat pump to continue to operate in cooling mode if this valve fails.

The liquid receiver enables the charge of R410A refrigerant to be optimised, particularly in cooling mode, in order to maintain a high COP value.

A capillary expansion device ensures and enables a wide operating range with water inlet temperatures which can vary between 11 °C and 45 °C at the minimum or maximum flow-rate.

Ventilation section

The fan compartment contains the fan-motor assembly, the air/refrigerant coil and the condensate drain pan.

Wide removable panels provide access to the various internal components. The condensate drain pan has an anti-corrosion treatment.

All the units are equipped with fan motor with permanent magnet electronically commuted technology - EC motor -. The fan impeller is equipped with aerodynamically shaped blades limiting airflow noise. The impeller is of metal material. The scroll is of ABS material.

The 3 fan speeds can be controlled either manually or automatically by the electronic management board of the unit.

The standard configuration is in line air discharge in the axis of the return air. The L return air option is possible by permuting the side and the fan-motor assembly panels. The L discharge air option is carried out with a plenum.

The return air is available with either rectangular flange or with a circular collar of Ø200 mm and a fresh air circular collar of Ø100 or Ø125 mm.

Discharge air is available with either rectangular flange or Ø200 mm circular collar.

U version is available by combining L return air with a discharge plenum.

An air diffusion nozzle with internal deflector mounted at the fan outlet allows the air flow to be optimally distributed on the heat exchanger in order to ensure maximum heat exchange.

Fixation

Units are equipped with multi-position brackets for easy installation and holes specially dedicated for "gripfil" hanging.

In order to facilitate installation on site, a suspension kit consisting of rubber blocks and washers is supplied with the units.

Optional features (factory installed)

- ✓ Electric heater at discharge side (1200, 1600, 2000 W),
- ✓ General alarms fault report,
- ✓ Motorized water valve,
- ✓ Discharge plenum,
- ✓ Water flow switch.

Control Features

All **SYSLOOP** water source heat pumps are, in their standard version, equipped with a **Siemens POL423** electronic control system which manages their operation and their safety devices.

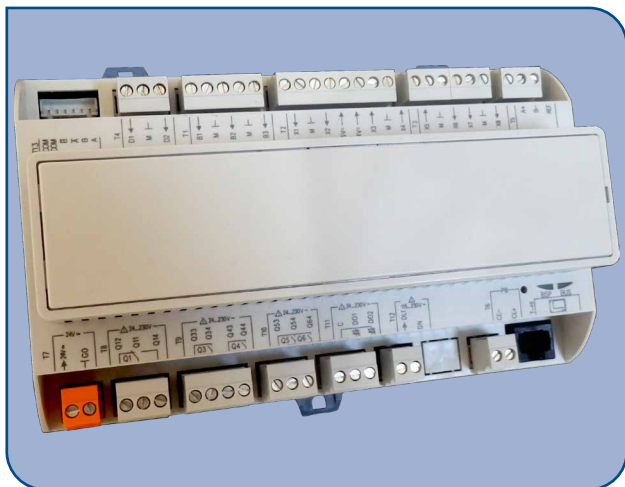

The configuration of the **POL423** electronic control enables **four different operating modes** for water source heat pumps by selecting the following systems :

- Thermodynamic cooling and heating operation;
- Thermodynamic cooling and heating operation or heating operation with an additional electric heater;
- Thermodynamic cooling operation and electrical heating operation;
- Thermodynamic cooling operation only.

Anti-freeze safety function : this is provided by two temperature sensors. In cooling mode an "ICT" temperature sensor located in the finned coil protects the water source heat pump against accidental freezing.

In heating mode, the safety function is provided by an "LWT" minimum water outlet temperature sensor.

The automatic reset LP pressure switch completes the anti-freeze safety function by monitoring a minimum acceptable suction pressure to ensure correct operation of the compressor.

High temperature safety function : the "ICT & LWT" temperature sensors check that the condensation temperature at the finned coil and the water temperature at the outlet of the water/refrigerant heat exchanger do not exceed the authorised limits.

The automatic reset HP pressure switch completes the high temperature safety function.

Electric heater : **SYSLOOP** water source heat pumps can be factory equipped with an optional in-duct air heater located at the fan outlet.

The electric heaters are also available in kit.

The electric heater function can, depending on the configuration of the **POL423** electronic control, be used in place of the thermodynamic heating as soon as the temperature in the water system drops below a minimum limit, or it can be used as an electric heating system on its own.

Units are factory equipped with **two electric heater stages**.

POL822 remote control

An **POL822 remote control** is supplied **as optional** in the electrical control box of the units.



It enables individually controlled operation or stand-alone regulation.

The **POL822 remote control** is ergonomically designed and discreet. It comprises a digital display and essential functions such as :

- On/Off,
- Selection of operating mode,
- Room temperature display,
- Fan speed selection,
- Temperature set-point adjustment
- Alarm code display

Master/slaves control : the standard version of the **POL423** electronic control enables operation in master/slaves regulation mode for **up to 15 water source heat pumps using a single POL822 remote control**.

This configuration enables the installer to save on the purchase and wiring of equipment such as auxiliary relays and multi-wire cables between the various water source heat pumps. Only a bus cable with 2 twisted pairs is necessary between the master and slave units.

Models designation

SL20	HP	H2	SYS	EC	GOM1	POL423	1200W	MBRT	ACB	TH	RD	R1	AI RECT	PV	AO XLN	PUMP	S4	AO RECT	IP
①	②	③	④	⑤	⑥	⑦	⑧	⑨	⑩	⑪	⑫	⑬	⑭	⑮	⑯	⑰	⑱	⑲	⑳

REP.	Description
① Size	SL15 : SYSLOOP size 15 SL20 : SYSLOOP size 20 SL30 : SYSLOOP size 30
② Version	CO : Cooling only HP : Heat pump
③ Hydraulic output	H1 : Lateral, right H2 : Rear face, right H3 : Rear face, left H4 : Lateral, left
④ Brand	SYS : Systemair
⑤ Fan type	EC : Fan with EC motor
⑥ Air filter	Blank : Without filter GOM1 : Basic filter G3M1 : G3M1 filter
⑦ Regulation	POL423 : POL423 SIEMENS (Modbus RTU / Bacnet MSTP) STORM2 : STORM2
⑧ Electric heater	Blank : Without heater 1200W : Capacity 1200W 1600W : Capacity 1600W 2000W : Capacity 2000W
⑨ Communication protocol	Blank : Stand Alone MBRT : Modbus RTU BNMS : Bacnet MSTP
⑩	ACB : Circuit breaker
⑪ Remote control	Blank : Without remote control TH : POL822 RCX : RCX
⑫ Option	RD : General default report RS : Room temperature sensor FS : Flow switch
⑬ Air inlet	R1 : Lateral, left R2 : Frontal, left R3 : Frontal, right R4 : Lateral, right
⑭ Air inlet accessories	Blank : Without AI RECT : Rectangular filter frame AI 10200 : Filter frame + duct Ø200 AI 10200 FAØ100 : Filter frame + duct Ø200 + duct fresh air Ø100 AI 10200 FAØ125 : Filter frame + duct Ø200 + duct fresh air Ø125
⑮ Water regulating valve	Blank : Without PV : Pressostatic valve
⑯ Acoustic	Blank : Standard Low Noise AI XLN : Extra low noise - Air inlet AO XLN : Extra low noise - Air outlet AI AO XLN : Extra low noise - Air inlet + Air outlet
⑰ Lift pump	Blank : Without PUMP : Drain pump
⑱ Air outlet	S1 : Lateral, left S2 : Frontal, left S3 : Frontal, right S4 : Lateral, right
⑲ Air outlet accessories	Blank : Without AO RECT : Rectangular frame AO 10200 : Frame + duct Ø200
⑳ Option	IP : Individual Packaging

Product Codes

	Product codes	Description
SL15	374261	SL15.HP.H2.EC.GOM1.STORM2.RCX.R1.AI RECT.S4.AO 1xØ200.IP
SL20	374262	SL20.HP.H2.EC.GOM1.STORM2.RCX.R1.AI RECT.S4.AO 1xØ200.IP
SL30	374263	SL30.HP.H2.EC.GOM1.STORM2.RCX.R1.AI RECT.S4.AO 1xØ200.IP

Refrigerant Flow Diagram

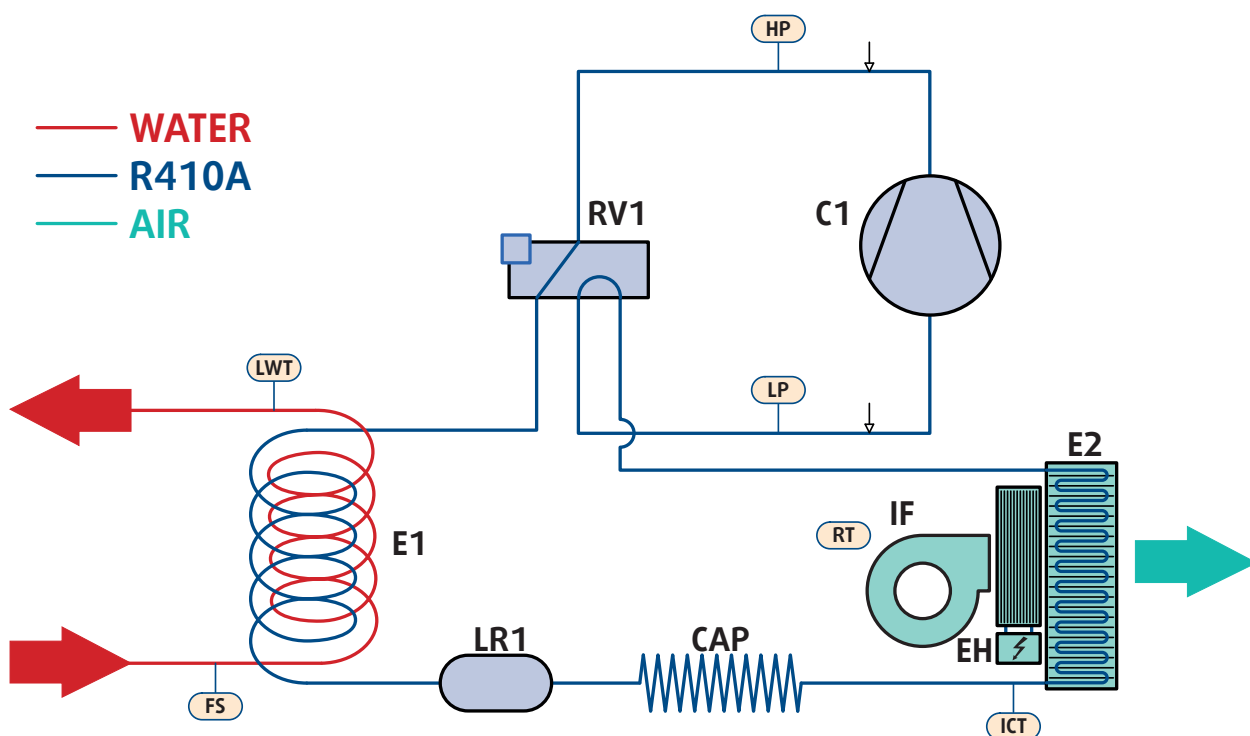

C1	Compressor	E2	Finned coil	LP	Low pressure switch
RV1	Cycle reversal valve	IF	Fan	LWT	Outlet water temperature sensor
E1	Coaxial heat exchanger	EH	Electric heating coil (option)	FS	Flow switch (option)
LR1	Liquid receiver	↓	Schrader valve	ICT	Anti-freezing protection sensor
CAP	Expansion device	HP	High pressure switch	RT	Air temperature sensor

Aeraulic configuration

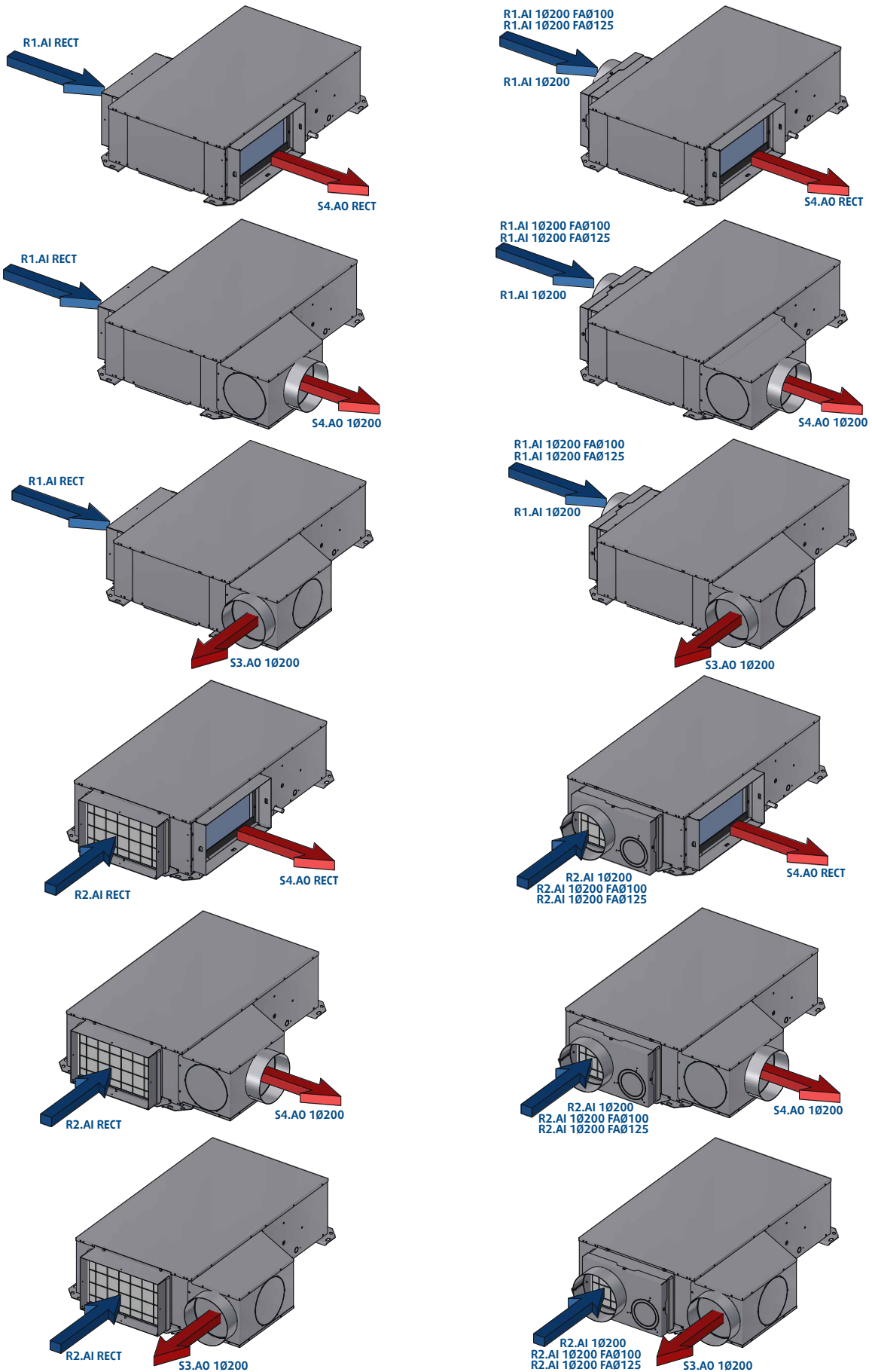

Operating Limits

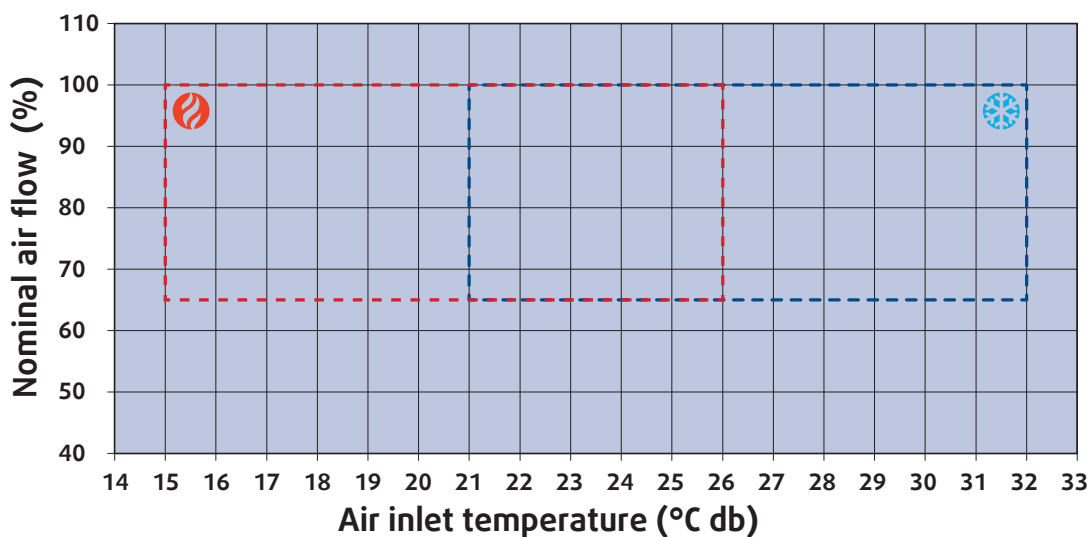
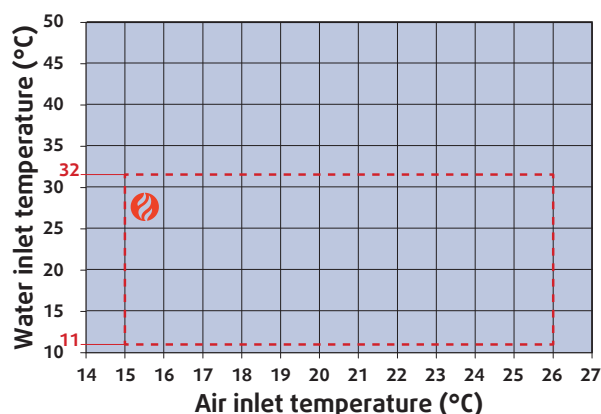
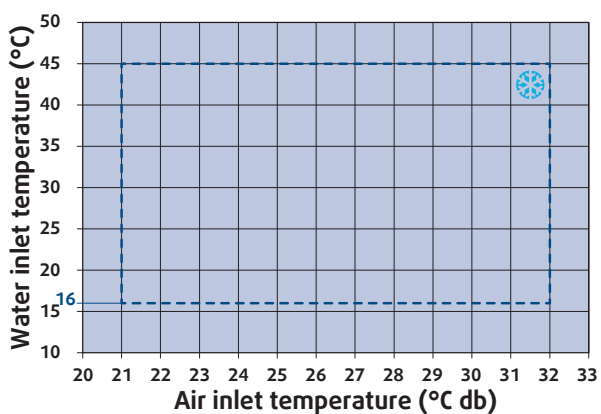

MODELS		SL15	SL20	SL30
Nominal air flow	m ³ /h	435	465	525
65% Nominal air flow	m ³ /h	261	279	315

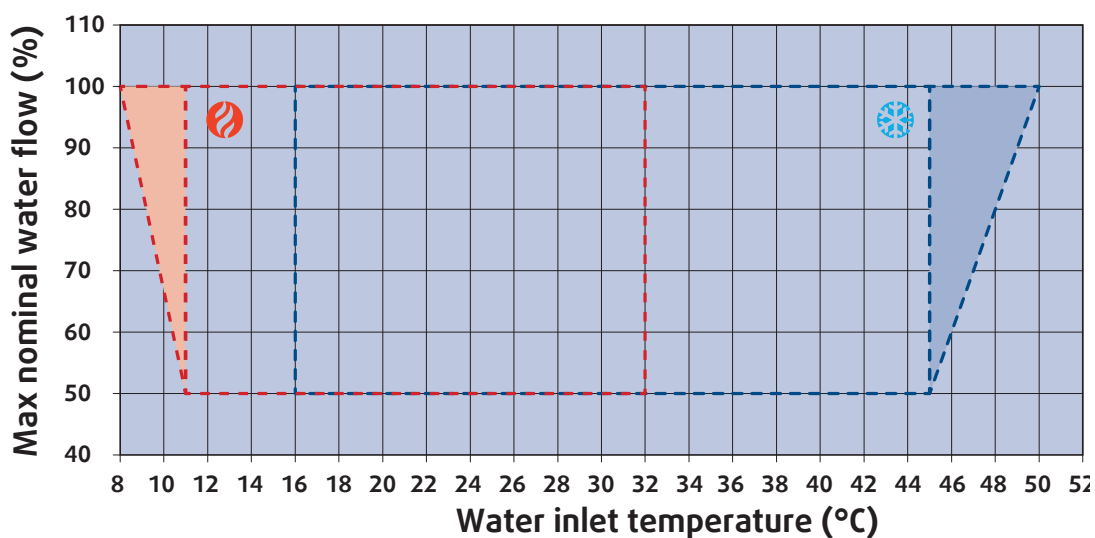

MODELS		SL15	SL20	SL30
Nominal water flow	l/h	317	444	617
50% Nominal water flow	l/h	158.5	222	308.5
Maximum hydraulic pressure	bar	10	10	10

Physical Data

MODELS		SL15	SL20	SL30
Total cooling capacities (1)	W	1 507	2 151	2 902
Sensible cooling capacities (1)	W	1 371	1 733	2 355
Heating capacities (2)	W	1 934	2 510	3 680
VENTILATION				
Nominal air flow	m ³ /h	435	465	525
Motor power	W	24	38	53
Air filter - Number / Efficiency		1/Basic ou 1/G3		
Air filter - Dimensions / Thickness	mm	225 x 366 / 23		
HYDRAULIC CIRCUIT				
Number of heat exchanger		1		
Maximum water pressure	bar	10		
Nominal water flow	l/h	317	444	617
Water pressure drop at nominal water flow	kPa	8	12	18
Hydraulic connections - Inlet/Outlet	inches	Ø 1/2" Gas male		
Condensate outlet - External Ø	mm	16		
REFRIGERANT CIRCUIT				
Number of circuit		1		
Compressor type		Rotary		
Load	g	415	565	565
DIMENSIONAL DATA & WEIGHT				
Length	mm	900	900	900
Width	mm	530	530	530
Height	mm	250	250	250
Weight - Operating	kg	48	48	48
Weight - Shipping	kg	52	52	52
ELECTRICAL DATA				
Power input - Cooling mode (3)	W	365	471	742
Power input - Heating mode (3)	W	389	491	806
Electrical heating coil - Number / Capacity (4)	- / W	1 / 600 + 600	1 / 800 + 800	1 / 1 000 + 1 000
Electric heater power input (4)	W	1 200	1 600	2 000
Electrical power supply		230V / 1Ph / 50Hz ±10%		

(1) Nominal cooling capacities based on entering air temperature of 27 °C dry bulb, 19 °C wet bulb with entering water temperature of 30 °C.

(2) Nominal heating capacities based on entering air temperature of 20 °C dry bulb, 15 °C wet bulb with entering water temperature of 20 °C.

(3) Power input at nominal conditions (compressor+fan at high speed).

(4) Electric heating coil is available optional.

Air Flow Data

MODEL SL15 BASIC FILTER - WITHOUT PLENUN

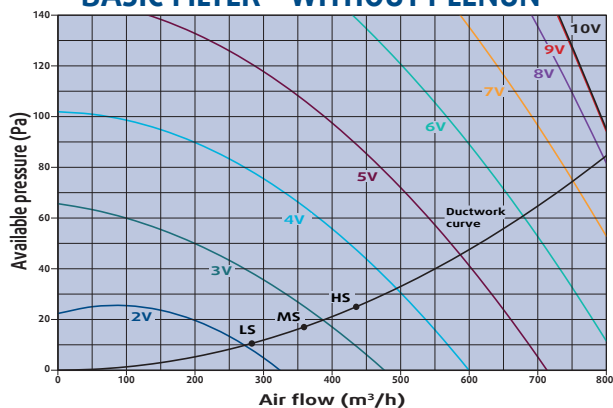

BASIC FILTER - WITH PLENUN

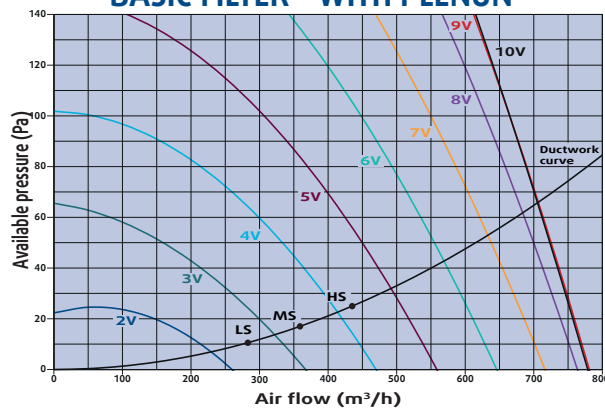

G3 FILTER - WITHOUT PLENUN

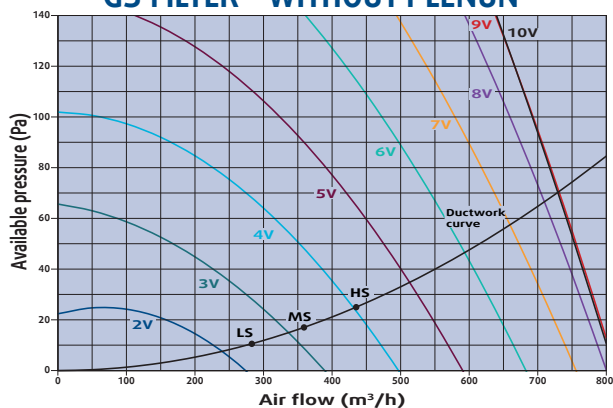

G3 FILTER - WITH PLENUN

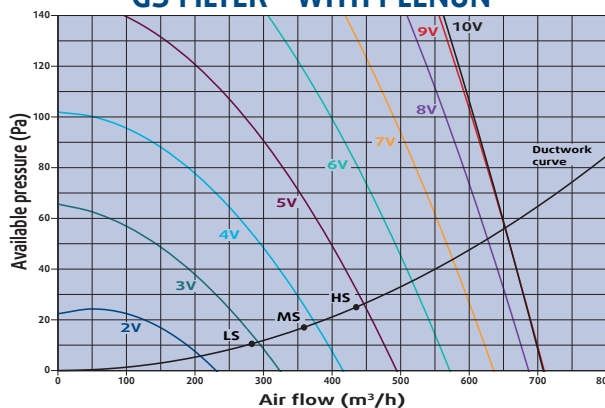

MODELS SL20 - SL30 BASIC FILTER - WITHOUT PLENUN

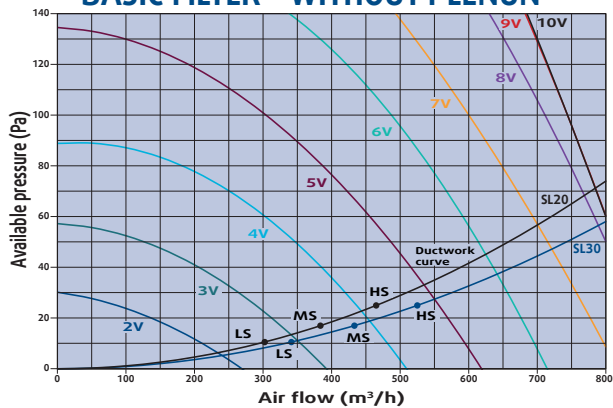

BASIC FILTER - WITH PLENUN

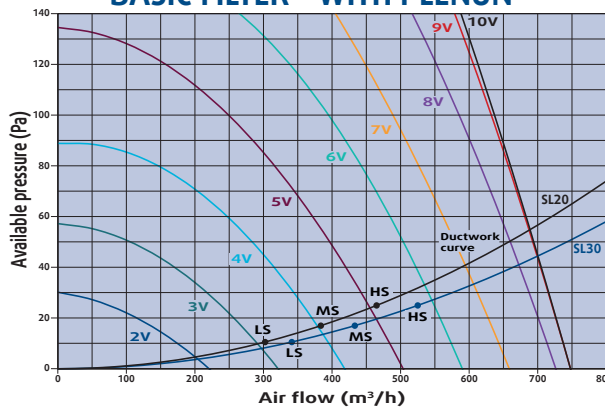

G3 FILTER - WITHOUT PLENUN

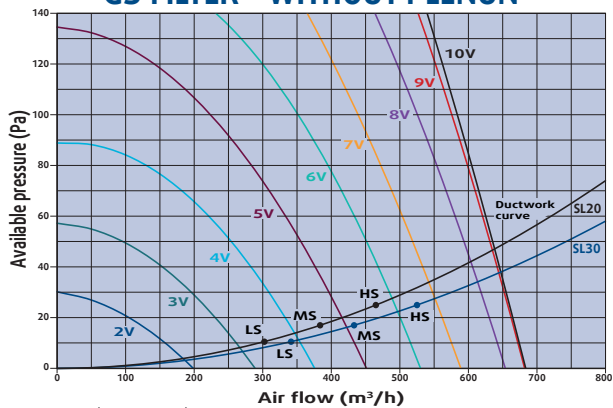

G3 FILTER - WITH PLENUN

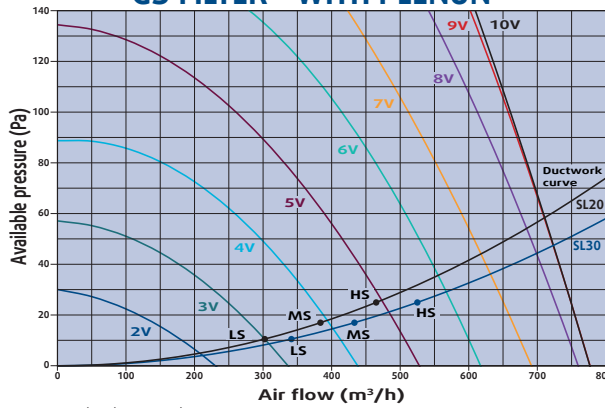

LS : low speed
MS : medium speed

HS : high speed

Acoustical Data

SL15

Speeds	Type	Power level per octave band Lw dB						Lw dB(A)	Lp global dB(A) ⁽¹⁾	NR ⁽¹⁾
		125	250	500	1 000	2 000	4 000			
LS	Return	45.0	42.8	39.1	36.0	26.9	21.6	40.8	27.1	22.4
	Radiated	50.8	44.7	40.2	31.2	22.5	18.5	41.9		
	Discharge	46.6	45.5	42.2	42.3	35.8	28.3	45.6		
MS	Return	48.0	45.5	42.1	39.1	31.0	26.1	43.9	30.0	25.7
	Radiated	52.1	45.8	41.4	33.2	25.1	20.8	43.1		
	Discharge	49.5	48.7	45.5	45.7	40.0	32.9	49.1		
HS	Return	51.4	48.5	45.4	42.6	35.5	31.2	47.3	33.5	29.4
	Radiated	53.7	47.1	42.7	35.5	28.1	23.5	44.4		
	Discharge	52.8	52.2	49.1	49.5	44.6	38.1	53.0		

SL20

Speeds	Type	Power level per octave band Lw dB						Lw dB(A)	Lp global dB(A) ⁽¹⁾	NR ⁽¹⁾
		125	250	500	1 000	2 000	4 000			
LS	Return	49.2	45.3	42.4	39.8	31.6	27.0	44.2	30.0	25.8
	Radiated	54.4	44.9	40.9	32.6	26.0	22.4	42.7		
	Discharge	49.5	48.7	45.5	45.7	40.0	32.9	49.1		
MS	Return	52.6	48.8	46.2	43.7	36.7	32.6	48.1	34.1	30.1
	Radiated	55.8	46.6	42.6	35.6	29.4	25.3	44.5		
	Discharge	53.3	52.7	49.6	50.1	45.3	38.9	53.6		
HS	Return	56.2	52.4	50.1	47.7	41.8	38.2	52.2	38.4	34.4
	Radiated	57.4	48.7	44.6	38.7	33.0	28.4	46.5		
	Discharge	57.2	56.8	53.9	54.5	50.7	44.9	58.3		

SL30

Speeds	Type	Power level per octave band Lw dB						Lw dB(A)	Lp global dB(A) ⁽¹⁾	NR ⁽¹⁾
		125	250	500	1 000	2 000	4 000			
LS	Return	53.2	47.3	45.2	43.3	35.7	32.5	47.3	32.7	28.6
	Radiated	60.6	44.3	41.9	33.9	29.8	28.8	45.0		
	Discharge	51.8	51.1	47.9	48.2	43.1	36.4	51.7		
MS	Return	56.1	51.7	49.6	47.7	41.3	37.9	51.8	37.6	33.6
	Radiated	60.8	47.2	44.3	38.2	33.7	30.9	46.8		
	Discharge	56.3	55.9	52.9	53.5	49.4	43.5	57.2		
HS	Return	58.8	55.4	53.4	51.5	46.2	42.6	55.7	42.0	37.9
	Radiated	61.1	50.0	46.6	41.9	37.2	33.3	48.9		
	Discharge	60.2	60.0	57.2	57.9	54.7	49.5	61.9		

Data given for a unit with :

- 25 Pa external static pressure in High Speed.
- In-line configuration with filter.

(1) Informative data, considering an hypothetical sound attenuation of the room and installation of 21 dB.

Acoustical Data (continued)

SL15 AI XLN

Speeds	Type	Power level per octave band Lw dB						Lw dB(A)	Lp global dB(A) ⁽¹⁾	NR ⁽¹⁾
		125	250	500	1 000	2 000	4 000			
LS	Return	46.9	41.8	37.6	31.9	19.5	15.2	38.9	26.9	22.0
	Radiated	48.8	43.5	42.1	31.9	20.8	16.4	42.3		
	Discharge	46.6	45.5	42.2	42.3	35.8	28.3	45.6		
MS	Return	49.6	44.4	40.8	35.2	23.7	19.7	41.9	29.7	25.3
	Radiated	50.5	44.8	42.8	33.6	24.1	18.8	43.2		
	Discharge	49.5	48.7	45.5	45.7	40.0	32.9	49.1		
HS	Return	52.6	47.3	44.3	38.7	28.3	24.7	45.2	33.2	29.0
	Radiated	52.6	46.4	43.7	35.7	27.6	21.8	44.5		
	Discharge	52.8	52.2	49.1	49.5	44.6	38.1	53.0		

SL20 AI XLN

Speeds	Type	Power level per octave band Lw dB						Lw dB(A)	Lp global dB(A) ⁽¹⁾	NR ⁽¹⁾
		125	250	500	1 000	2 000	4 000			
LS	Return	50.7	44.2	41.1	35.8	24.2	20.6	42.1	29.7	25.3
	Radiated	52.7	43.9	42.1	33.1	25.1	20.5	42.7		
	Discharge	49.5	48.7	45.5	45.7	40.0	32.9	49.1		
MS	Return	53.8	47.7	45.2	39.8	29.4	26.0	45.9	33.7	29.6
	Radiated	54.7	46.0	43.5	35.8	29.1	23.6	44.4		
	Discharge	53.3	52.7	49.6	50.1	45.3	38.9	53.6		
HS	Return	57.0	51.2	49.3	43.9	34.7	31.6	49.8	38.1	34.0
	Radiated	56.9	48.4	45.1	38.7	33.2	27.2	46.5		
	Discharge	57.2	56.8	53.9	54.5	50.7	44.9	58.3		

SL30 AI XLN

Speeds	Type	Power level per octave band Lw dB						Lw dB(A)	Lp global dB(A) ⁽¹⁾	NR ⁽¹⁾
		125	250	500	1 000	2 000	4 000			
LS	Return	54.5	46.2	44.0	39.2	28.1	25.5	44.9	32.2	27.9
	Radiated	59.0	43.6	42.7	34.3	29.4	26.4	44.4		
	Discharge	51.8	51.1	47.9	48.2	43.1	36.4	51.7		
MS	Return	57.1	50.4	48.7	43.9	34.0	31.0	49.3	37.1	33.0
	Radiated	60.0	46.8	44.8	38.2	33.9	29.3	46.6		
	Discharge	56.3	55.9	52.9	53.5	49.4	43.5	57.2		
HS	Return	59.5	54.1	52.7	47.8	39.1	36.0	53.2	41.6	37.4
	Radiated	61.0	49.8	46.9	41.5	37.8	32.3	48.9		
	Discharge	60.2	60.0	57.2	57.9	54.7	49.5	61.9		

Data given for a unit with :

- 25 Pa external static pressure in High Speed.
- In-line configuration with filter.

(1) Informative data, considering an hypothetical sound attenuation of the room and installation of 21 dB.

Acoustical Data (continued)

SL15 A0 XLN

Speeds	Type	Power level per octave band Lw dB						Lw dB(A)	Lp global dB(A) ⁽¹⁾	NR ⁽¹⁾
		125	250	500	1 000	2 000	4 000			
LS	Return	45.0	42.8	39.1	36.0	26.9	21.6	40.8	23.7	18.1
	Radiated	50.8	44.7	40.2	31.2	22.5	18.5	41.9		
	Discharge	37.4	36.8	29.7	26.6	13.5	9.4	32.3		
MS	Return	48.0	45.5	42.1	39.1	31.0	26.1	43.9	25.8	20.3
	Radiated	52.1	45.8	41.4	33.2	25.1	20.8	43.1		
	Discharge	39.8	39.6	32.8	29.4	17.6	14.0	35.2		
HS	Return	51.4	48.5	45.4	42.6	35.5	31.2	47.3	28.5	22.9
	Radiated	53.7	47.1	42.7	35.5	28.1	23.5	44.4		
	Discharge	42.7	42.9	36.3	32.5	22.1	19.1	38.5		

SL20 A0 XLN

Speeds	Type	Power level per octave band Lw dB						Lw dB(A)	Lp global dB(A) ⁽¹⁾	NR ⁽¹⁾
		125	250	500	1 000	2 000	4 000			
LS	Return	49.2	45.3	42.4	39.8	31.6	27.0	44.2	25.8	20.2
	Radiated	54.4	44.9	40.9	32.6	26.0	22.4	42.7		
	Discharge	39.8	39.6	32.8	29.4	17.6	14.0	35.2		
MS	Return	52.6	48.8	46.2	43.7	36.7	32.6	48.1	29.0	23.6
	Radiated	55.8	46.6	42.6	35.6	29.4	25.3	44.5		
	Discharge	43.2	43.4	36.9	33.0	22.9	19.9	39.0		
HS	Return	56.2	52.4	50.1	47.7	41.8	38.2	52.2	32.6	27.5
	Radiated	57.4	48.7	44.6	38.7	33.0	28.4	46.5		
	Discharge	46.9	47.2	41.0	36.7	28.2	26.0	43.0		

SL30 A0 XLN

Speeds	Type	Power level per octave band Lw dB						Lw dB(A)	Lp global dB(A) ⁽¹⁾	NR ⁽¹⁾
		125	250	500	1 000	2 000	4 000			
LS	Return	53.2	47.3	45.2	43.3	35.7	32.5	47.3	28.6	24.2
	Radiated	60.6	44.3	41.9	33.9	29.8	28.8	45.0		
	Discharge	41.8	41.8	35.2	31.5	20.7	17.4	37.4		
MS	Return	56.1	51.7	49.6	47.7	41.3	37.9	51.8	32.3	27.4
	Radiated	60.8	47.2	44.3	38.2	33.7	30.9	46.8		
	Discharge	46.0	46.3	40.0	35.9	26.9	24.5	42.0		
HS	Return	58.8	55.4	53.4	51.5	46.2	42.6	55.7	35.9	31.2
	Radiated	61.1	50.0	46.6	41.9	37.2	33.3	48.9		
	Discharge	49.9	50.1	44.3	39.6	32.3	30.7	46.1		

Data given for a unit with :

- 25 Pa external static pressure in High Speed.
- In-line configuration with filter.

(1) Informative data, considering an hypothetical sound attenuation of the room and installation of 21 dB.

Acoustical Data (continued)

SL15 AI AO XLN

Speeds	Type	Power level per octave band Lw dB						Lw dB(A)	Lp global dB(A) ⁽¹⁾	NR ⁽¹⁾
		125	250	500	1 000	2 000	4 000			
LS	Return	46.9	41.8	37.6	31.9	19.5	15.2	38.9	23.2	18.8
	Radiated	48.8	43.5	42.1	31.9	20.8	16.4	42.3		
	Discharge	36.2	36.9	29.3	26.3	13.4	9.5	32.2		
MS	Return	49.6	44.4	40.8	35.2	23.7	19.7	41.9	25.0	20.4
	Radiated	50.5	44.8	42.8	33.6	24.1	18.8	43.2		
	Discharge	38.9	39.8	32.6	29.2	17.6	14.2	35.2		
HS	Return	52.6	47.3	44.3	38.7	28.3	24.7	45.2	27.3	22.7
	Radiated	52.6	46.4	43.7	35.7	27.6	21.8	44.5		
	Discharge	42.0	42.9	36.2	32.5	22.2	19.4	38.5		

SL20 AI AO XLN

Speeds	Type	Power level per octave band Lw dB						Lw dB(A)	Lp global dB(A) ⁽¹⁾	NR ⁽¹⁾
		125	250	500	1 000	2 000	4 000			
LS	Return	50.7	44.2	41.1	35.8	24.2	20.6	42.1	24.8	20.1
	Radiated	52.7	43.9	42.1	33.1	25.1	20.5	42.7		
	Discharge	39.6	39.0	32.3	28.7	16.6	14.8	34.7		
MS	Return	53.8	47.7	45.2	39.8	29.4	26.0	45.9	27.7	23.0
	Radiated	54.7	46.0	43.5	35.8	29.1	23.6	44.4		
	Discharge	42.6	42.7	36.4	32.5	22.0	20.4	38.5		
HS	Return	57.0	51.2	49.3	43.9	34.7	31.6	49.8	31.0	26.4
	Radiated	56.9	48.4	45.1	38.7	33.2	27.2	46.5		
	Discharge	46.1	46.5	40.6	36.4	27.5	26.0	42.5		

SL30 AI AO XLN

Speeds	Type	Power level per octave band Lw dB						Lw dB(A)	Lp global dB(A) ⁽¹⁾	NR ⁽¹⁾
		125	250	500	1 000	2 000	4 000			
LS	Return	54.5	46.2	44.0	39.2	28.1	25.5	44.9	27.0	23.2
	Radiated	59.0	43.6	42.7	34.3	29.4	26.4	44.4		
	Discharge	43.6	39.9	34.0	29.9	18.0	19.7	36.1		
MS	Return	57.1	50.4	48.7	43.9	34.0	31.0	49.3	30.6	25.9
	Radiated	60.0	46.8	44.8	38.2	33.9	29.3	46.6		
	Discharge	45.4	44.4	38.8	34.5	24.5	24.7	40.6		
HS	Return	59.5	54.1	52.7	47.8	39.1	36.0	53.2	34.0	29.5
	Radiated	61.0	49.8	46.9	41.5	37.8	32.3	48.9		
	Discharge	48.0	48.4	42.9	38.4	30.1	29.3	44.6		

Data given for a unit with :

- 25 Pa external static pressure in High Speed.
- In-line configuration with filter.

(1) Informative data, considering an hypothetical sound attenuation of the room and installation of 21 dB.

Dimensions (mm)

CONFIGURATION R1.AI RECT/S4.AO RECT

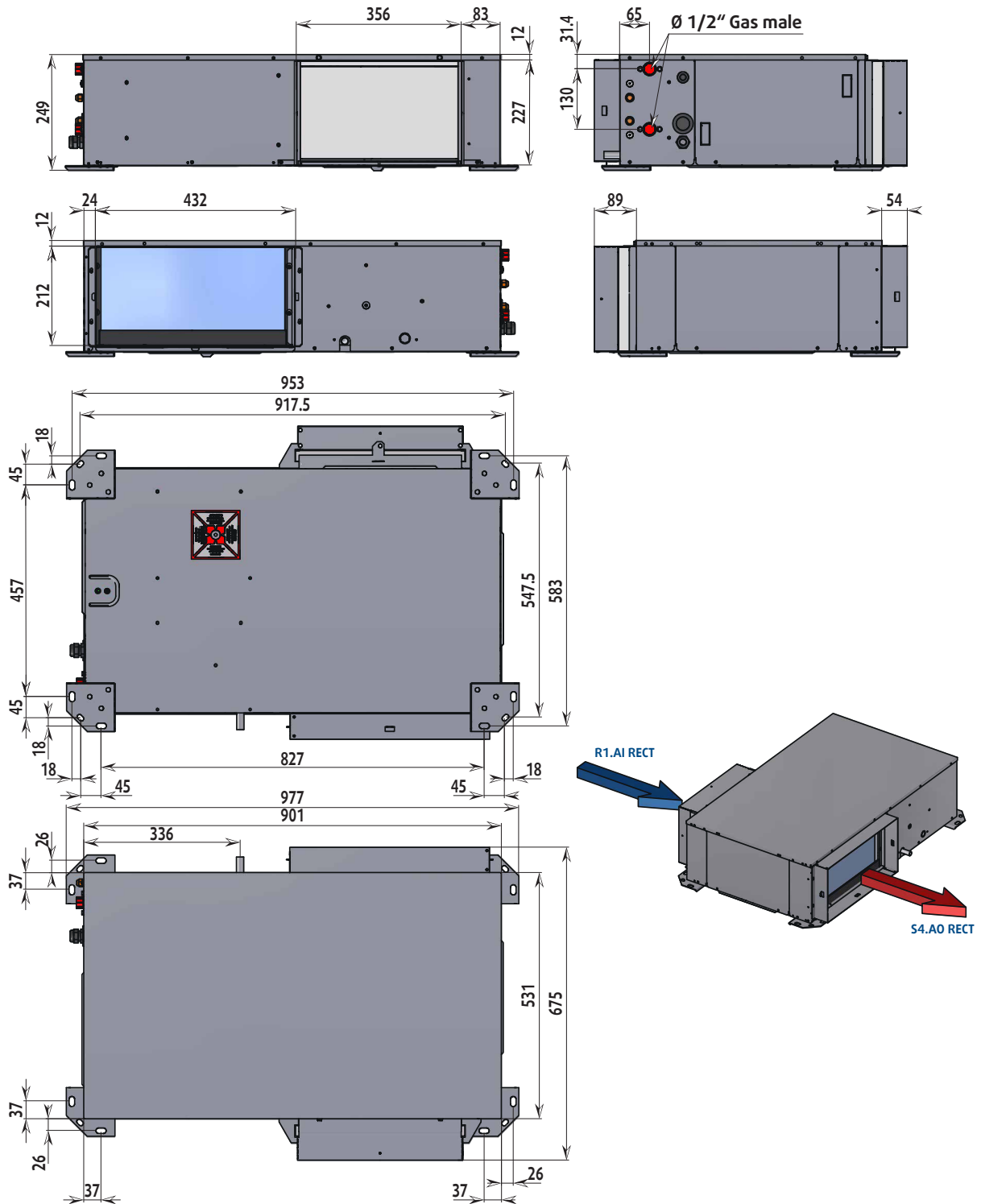

Dimensions (mm) (continued)

CONFIGURATION R2.AI RECT/S4.AO RECT

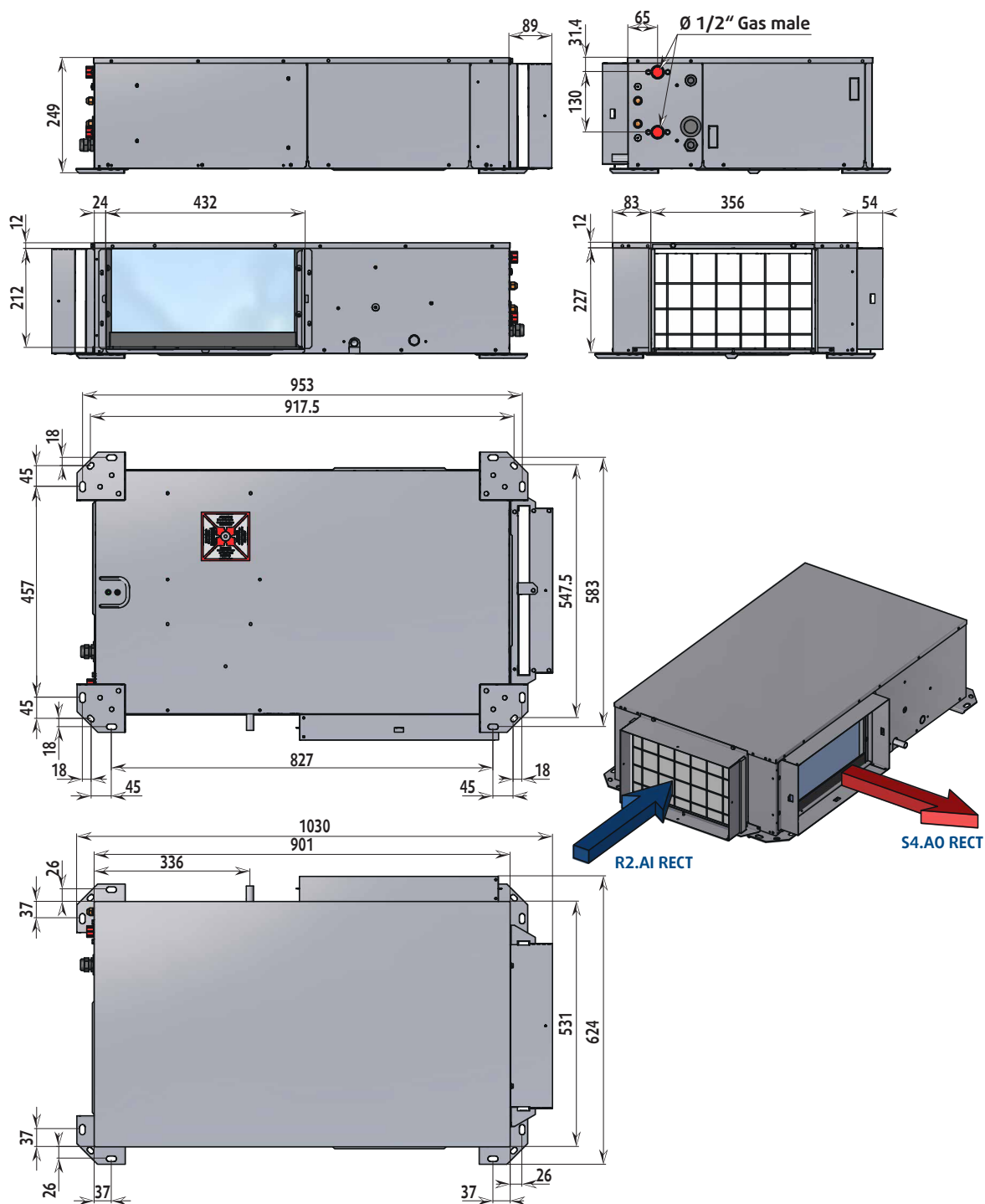

Dimensions (mm) (continued)

CONFIGURATION R1.AI 1Ø200/S4.AO RECT OR R1.AI 1Ø200 FAØ100/S4.AO RECT OR R1.AI 1Ø200 FAØ125/S4.AO RECT

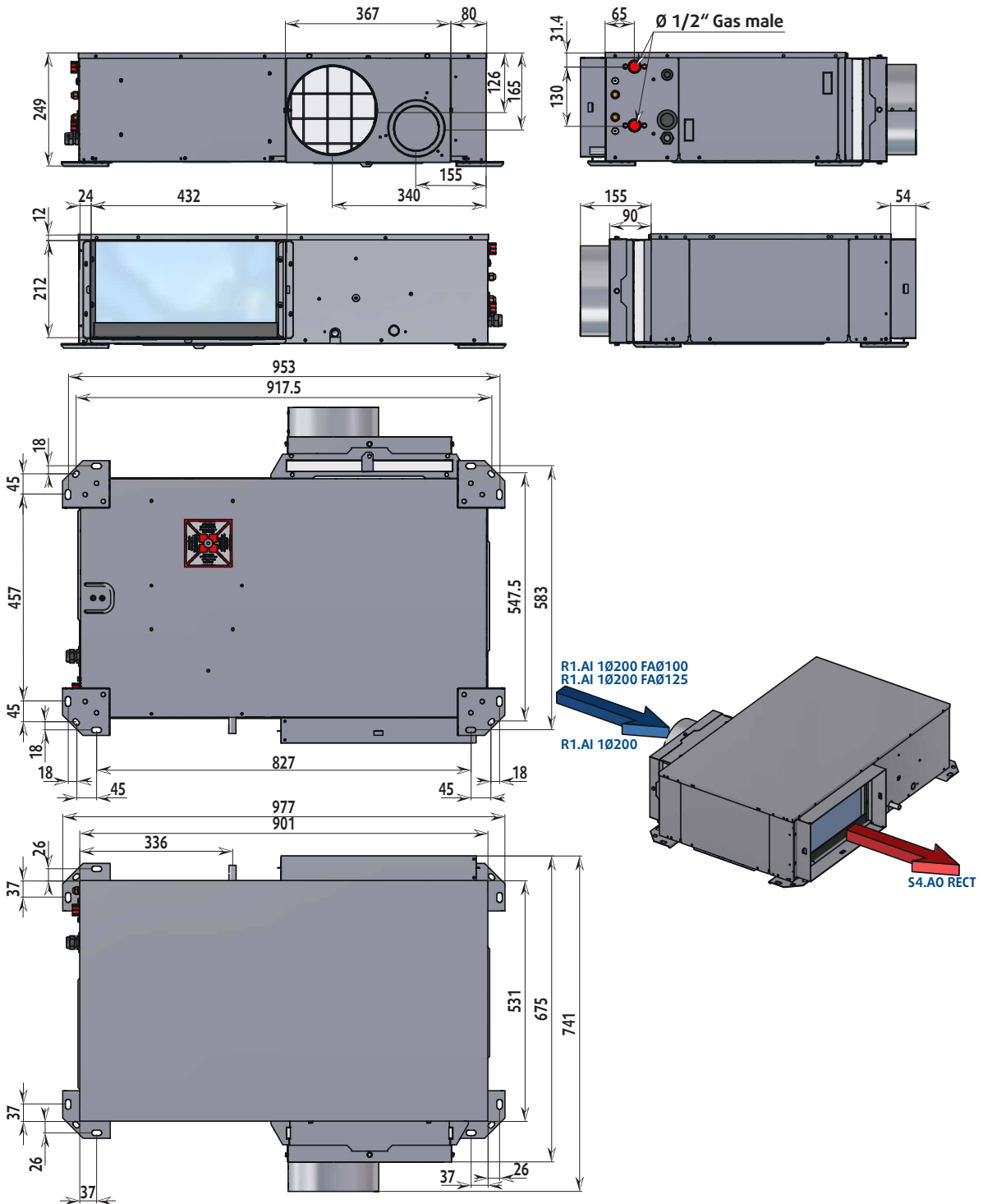

Dimensions (mm) (continued)

CONFIGURATION R2.AI 1Ø200/S4.AO RECT OR R2.AI 1Ø200 FAØ100/S4.AO RECT OR R2.AI 1Ø200 FAØ125/S4.AO RECT

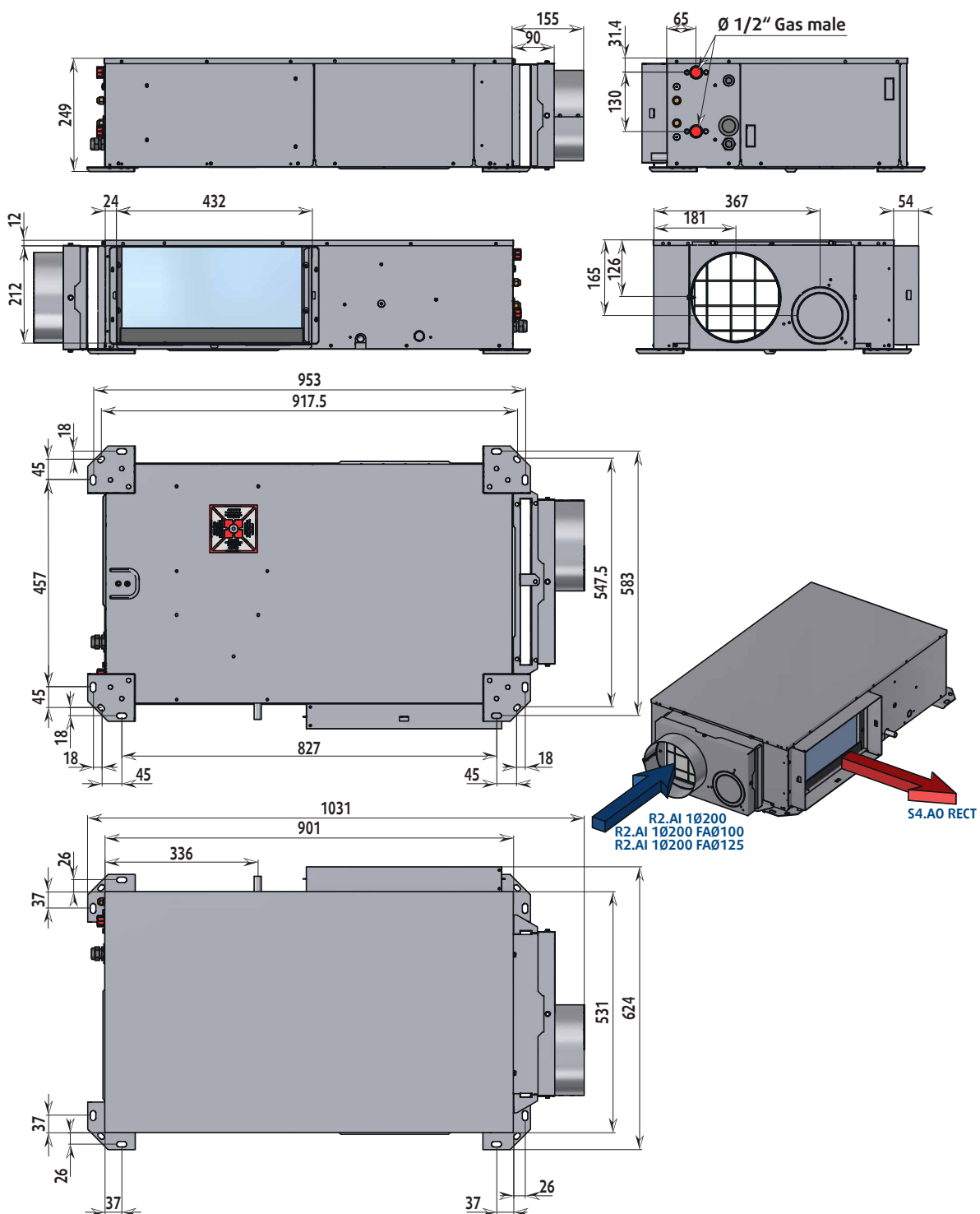

Dimensions (mm) (continued)

CONFIGURATION R1.AI RECT/S4.AO 1Ø200 OR R1.AI RECT/S3.AO 1Ø200

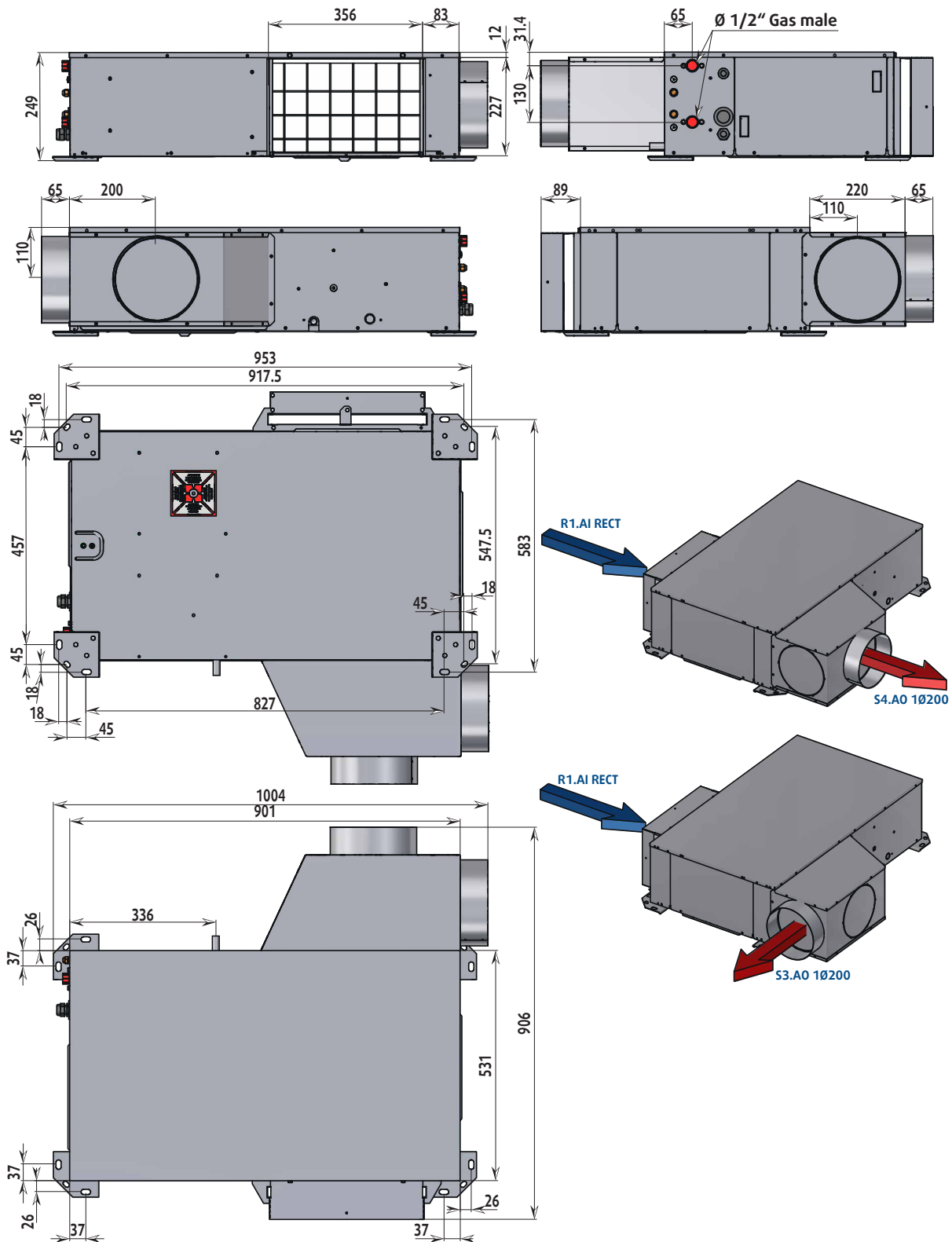

Dimensions (mm) (continued)

CONFIGURATION R1.AI 1Ø200/S4.AO 1Ø200 OR R1.AI 1Ø200 FAØ100/S4.AO 1Ø200 OR
 R1.AI 1Ø200 FAØ125/S4.AO 1Ø200 OR R1.AI 1Ø200/S3.AO 1Ø200 OR
 R1.AI 1Ø200 FAØ100/S3.AO 1Ø200 OR R1.AI 1Ø200 FAØ125/S3.AO 1Ø200

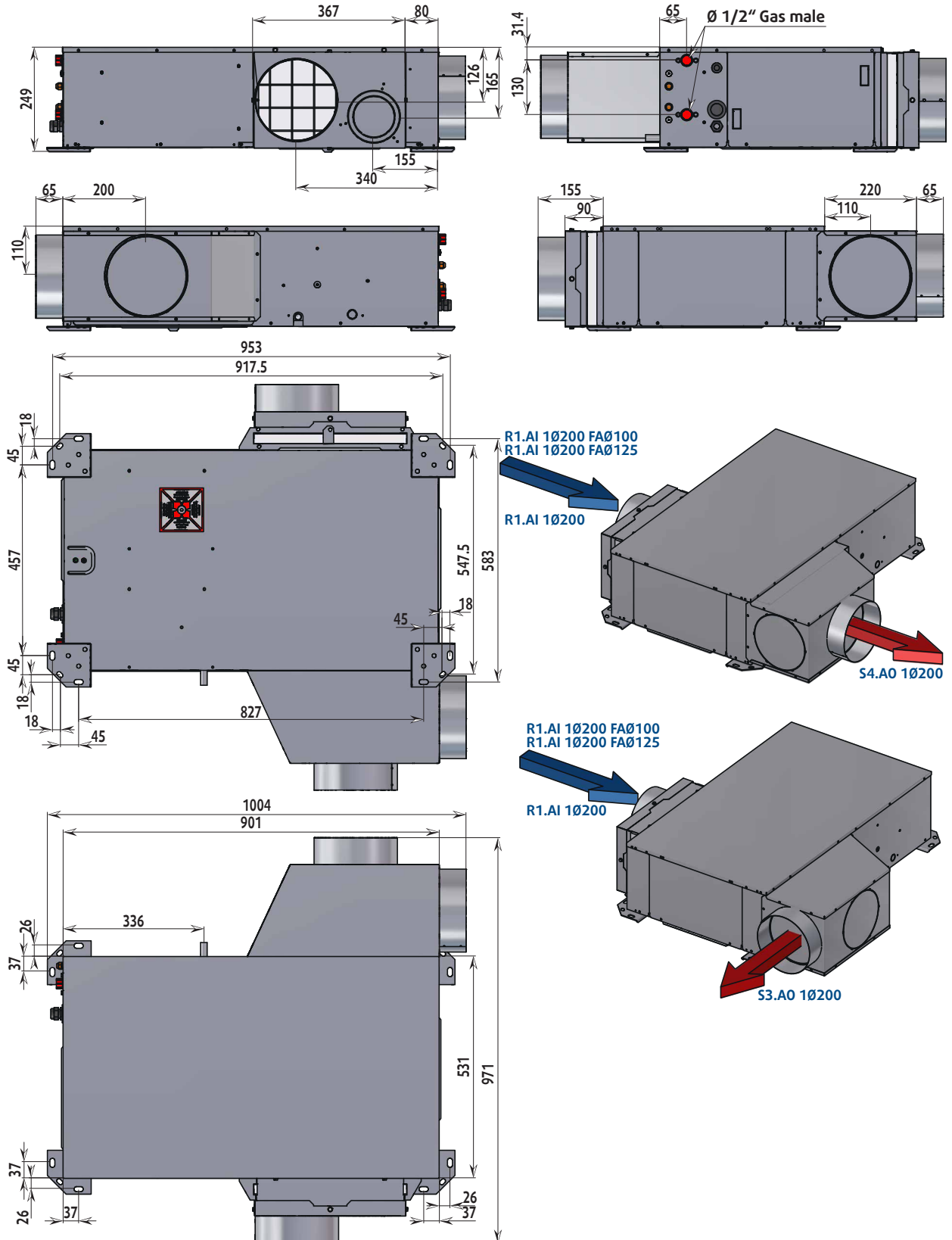

Dimensions (mm) (continued)

CONFIGURATION R2.AI 1Ø200/S4.AO 1Ø200 OR R2.AI 1Ø200 FAØ100/S4.AO 1Ø200 OR
R2.AI 1Ø200 FAØ125/S4.AO 1Ø200 OR R2.AI 1Ø200/S3.AO 1Ø200 OR
R2.AI 1Ø200 FAØ100/S3.AO 1Ø200 OR R2.AI 1Ø200 FAØ125/S3.AO 1Ø200

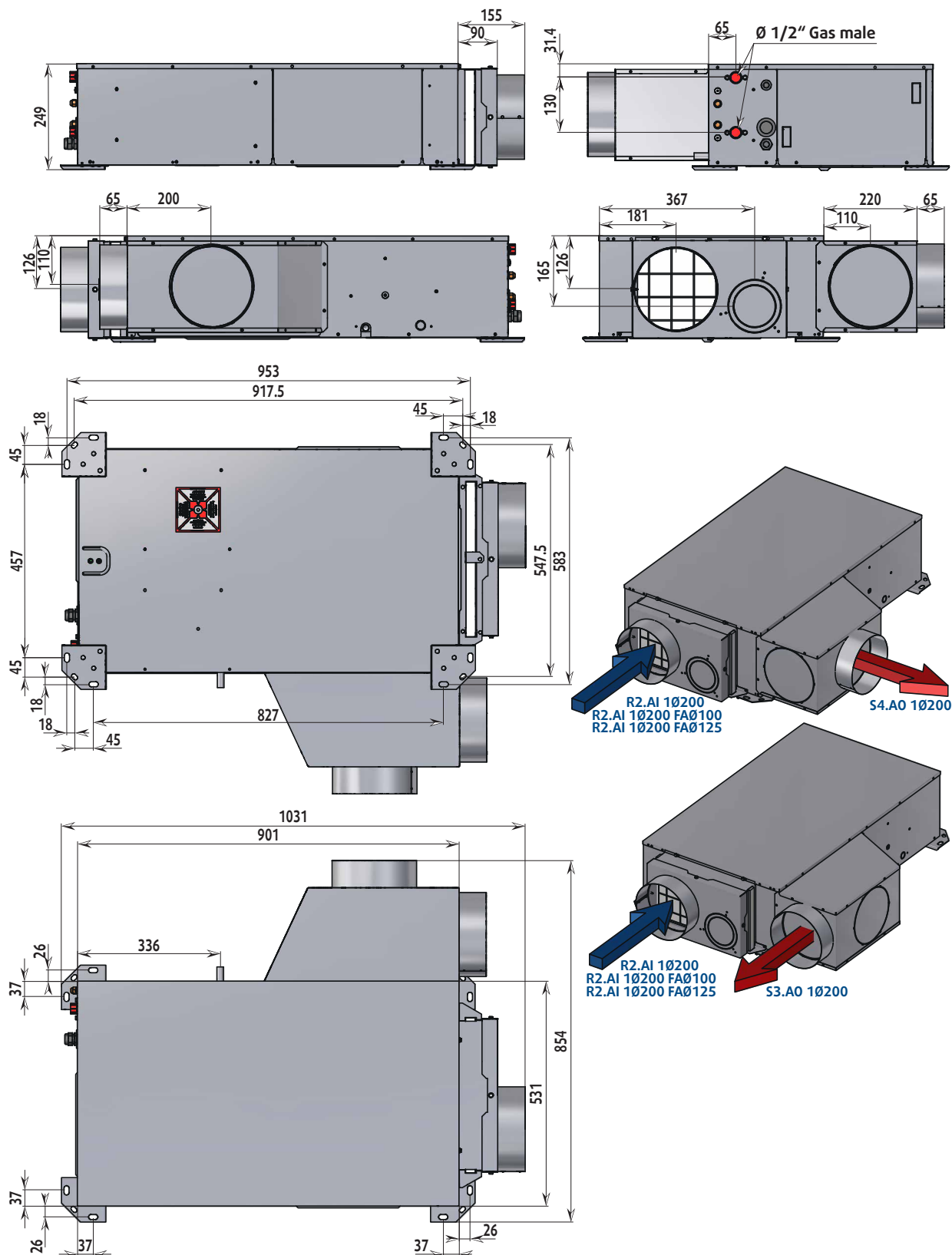

Dimensions (mm) (continued)

CONFIGURATION A0 XLN

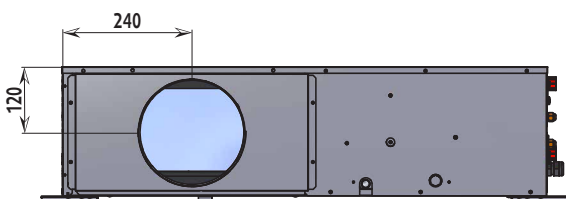
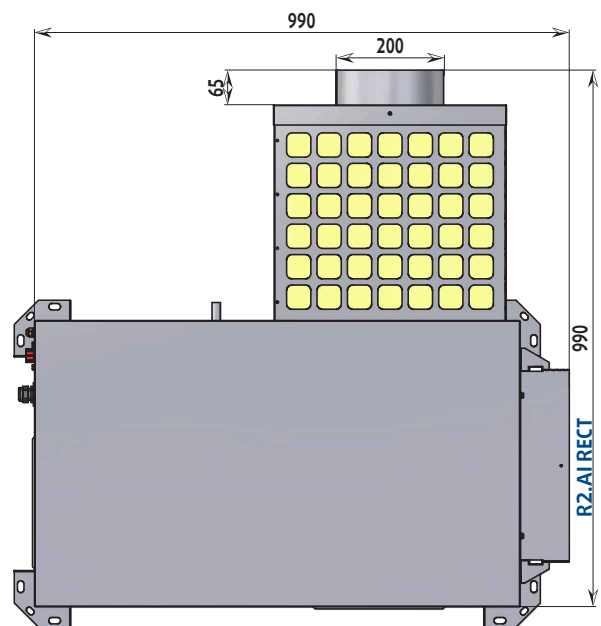
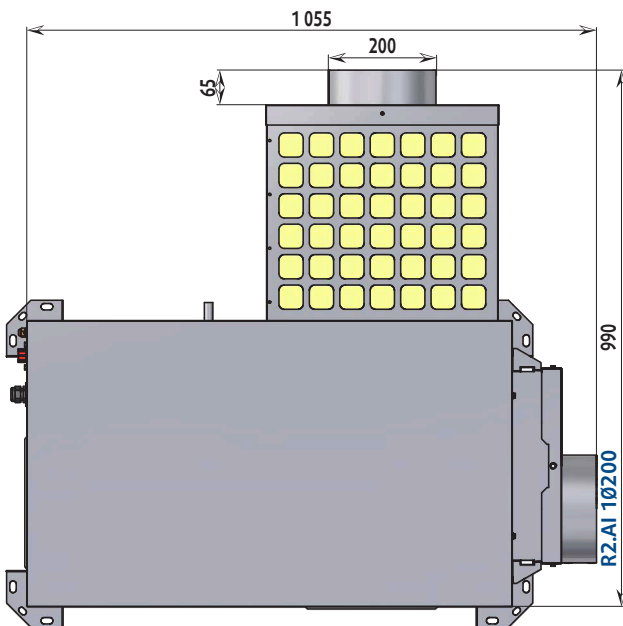
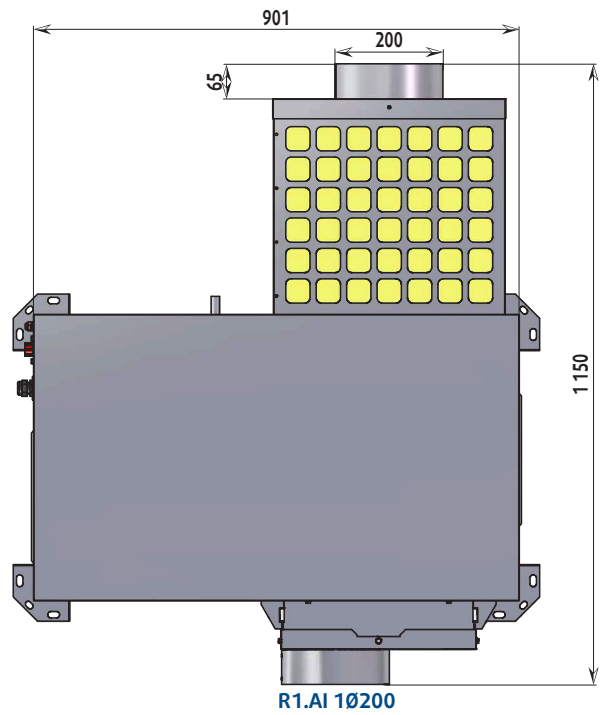
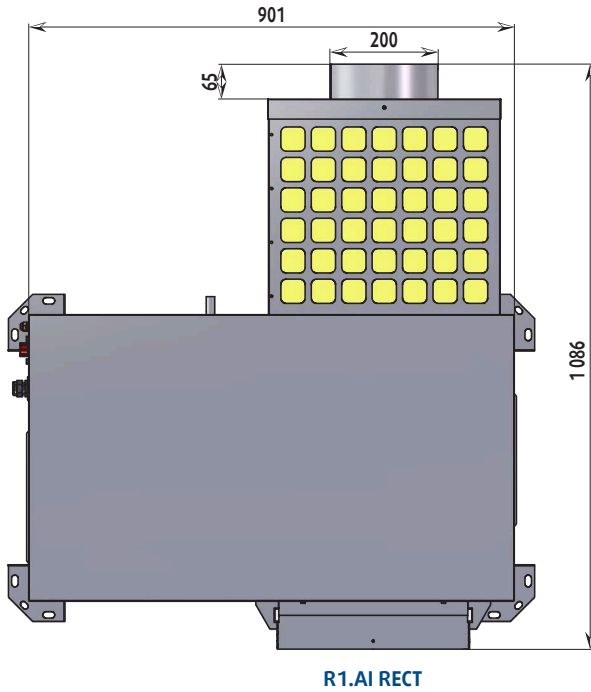

Notes

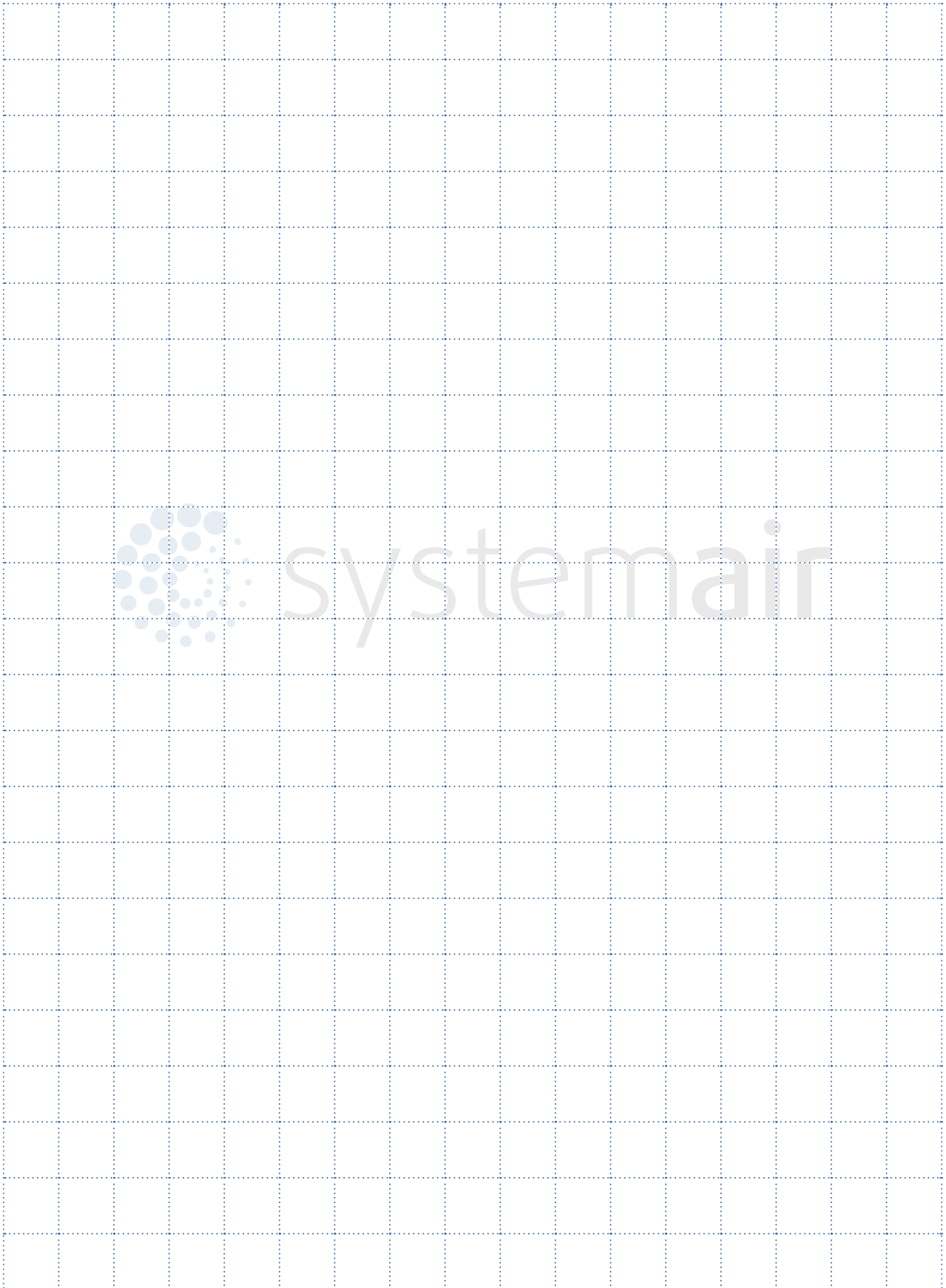

Systemair AC SAS · route de Verneuil, 27570 Tillières-sur- Avre · Tél. 02 32 60 61 00 · Fax 02 32 32 55 13
www.systemair.fr

