

VLH 704 to 1204

Air Cooled Water Chillers Heat Pump
Engineering Data Manual



173 to 300 kW



200 to 337 kW



Key points

- Units with [R410A refrigerant](#). As near azeotropic mixture it behaves like a homogeneous substance ([reduced service problems in case of leakage or re-charge](#)) with negligible temperature glide
- Units with EER values higher than 2.8 ([energy efficiency class C](#))
- With except for the fans, all the versions keep the same configuration of the base units (same structure, electrical board, compressors and coils). [Easy upgrade of the units in stock or on the field](#)
- [Bi-flow electronic expansion devices](#) on all units: superheating valve controlled by microprocessor, simple and accessible refrigeration system especially for heat pump versions with reduction of brazing points and than possible leakage
- Optimized coils design
- [Compressors box \(less sound proofing\) always installed](#) - additional compressors jackets only for S version ([easy upgrade of the units in stock](#))
- Special version (HSE) developed for high seasonal efficiency (SEER higher than 3.9) and high operation limits with inverter fans (electronic brushless type motor). Axial fan of large diameter
- Special version (HPF) for high external static pressure (max. 120 Pa) with inverter fans (electronic brushless type motor). Axial fan of large diameter. These fans are the same as those used on HSE units
- Modified and improved base frame – AVM fitted underneath of base frame so no brackets request (no problem for track and container freight). In the same positions, the plastic feet will be installed for fork handling
- [Hydro kits](#) with or without buffer tank (500 litres) fitted on board or on the back of the chiller to perform outstandingly the package solution and the plug & play concept
- One or two water pumps are available: standard pressure (100 kPa) or high pressure (200 kPa). The water pump has a sound proof box for S version. The hydro kit with buffer tank can be easily connected at the base frame of the unit by a special "structure kit". [Easy upgrade of the units in stock or on the field](#)
- For service operation, special valves dedicated to R410A are supplied on the refrigerant system. These valves, of 5/16" flare SAE type, are mounted on the liquid line and on the gauges manifold of the unit

Specifications

General description

The VLH units have been designed to operate with HFC 410A refrigerant. Both compressors and heat exchangers (plate heat exchanger and coils) have been optimized for this refrigerant.

They consist of two independent refrigerant circuits, a tandem high efficiency and low vibration level Scroll compressors on each circuit, a "True Dual" two-circuit plate heat exchanger and a ventilating unit comprising V-shape coils and quiet fans; each of them is located in an externally mounted nozzle profile housing generating low sound level.

The VLH units are available in 6 sizes, from size 704 to 1204, with a nominal capacity range from 173 to 300 kW in cooling mode and from 200 to 337 kW in heating mode.

The VLH STD (Standard) version can be supplied with 3 acoustic options:

- **Base Low Noise (STD)** : The units are equipped with delta connected fans implying a standard rpm. The chillers are not supplied with fan speed controller, but fitted with compressors box to reduce the noise emissions
- **Low Noise (L)** : The units are equipped with star connected fans implying a low rpm. The chillers are not supplied with fan speed controller, but fitted with compressors box to reduce the noise emissions
- **Extra Low Noise (S)** : The units are equipped with star connected fans, fitted with a speed controller which allows the units to operate with a very low rpm. The chillers are supplied with compressors box and soundproof jackets on compressors reducing significantly the noise emissions.

To increase their field of applications, the VLH ranges are available in 3 additional versions:

- **HSE (High Seasonal Efficiency) version**: It has same equipment as that of the STD version, except that the units are equipped with special inverter fans, of large diameter, driven by EC (electronic brushless type) motors with integrated electronic inverter, to ensure low energy consumption. This version can be supplied with STD, L or S acoustic options
- **HT (High Temperature) version**: It has same equipment as that of the STD units, but the units are fitted with special inverter fans and motors identical to those of the HSE version, but with a different regulation. The HT version can be supplied with STD acoustic option only
- **HPF (Special Inverter Fan) version**: It has same equipment as that of the STD units, except that the units are equipped with special inverter fans (same as those used on HSE version, but with a different regulation) driven by EC motors with integrated electronic inverter. The HPF version provides external static pressure up to 120 Pa. This version can be supplied with STD acoustic option only.

In addition, 1 heat recovery option is available:

- **Desuperheater**: All the versions can be supplied with plate type heat exchangers fitted, one on each refrigerant circuit, on the compressor discharge line to recover about 20 % of the total heat rejected to the condensers.

Conformity with standard

The following applies to all the sizes and versions of VLH units:

- Machine Directive: 2006/42/EC
- Electromagnetic Compatibility Directive: 2014/30/UE
- Pressure Equipment Directive: 2014/68/UE
- Ecodesign Directive: 2009/125/EC

Cabinet and structure

The unit cabinet and structure are made of heavy gauge galvanized steel coated with polyester powder based painting (RAL 9001). All parts of the structure are fastened totally with non-corrosive screws and bolts.

Compressors

Each unit is equipped with four compressors arranged in two tandems to suit the two refrigerant circuits.

The compressors are of hermetic scroll type and fitted with an electronic control system ensuring protection against high temperature and excessive load.

All compressors have direct-on-line starting and are mounted on rubber vibration isolators in order to minimize noise and vibration transmission.

Evaporator

Evaporator is of a "Dual Circuit" brazed stainless steel plate type heat exchanger. It is insulated with a 19 mm thick closed cell polyethylene foam material and is fitted with a film type electric heater on the external surface to prevent the unit from freezing at a low temperature (down to -18 °C) when the unit is off.

Water connections are of a Victaulic type : 2"1/2 on sizes 704 to 804 and 3" on sizes 904 to 1204.

Condenser coils

The condenser coils are made of seamless copper tubes, arranged in staggered rows, mechanically expanded into corrugated aluminum fins.

Condenser fans

For each size, all versions keep the same number of fans.

Large diameter, direct drive axial type fans with asynchronous three-phase motors are used in all acoustic versions (STD, L & S) of VLH 704-1204 STD units.

Special inverter fans with electronic brushless type motors are used in VLH 704-1204 HSE, HPF and HT units.

On high pressure fans of HPF units, the external static pressure (≤ 120 Pa) can be adjusted on site to match the customer demand directly from the electronic control panel of the unit.

Fans are equipped with externally mounted nozzle profile housing which generates low sound levels.

Fan Speed control

The speed of fans is controlled in order to operate at a low ambient temperature.

On units with standard axial fans, the fan speed control, supplied as standard, is of a temperature actuated step type (for STD and L versions) and of a pressure actuated stepless type with an electronic controller (for S version).

The pressure actuated stepless type fan speed controller can be supplied as optional on STD and L versions. It allows the units to operate in cooling mode at ambient temperature down to -18 °C.

On HSE and HPF units with electronic axial fans, the pressure actuated stepless type fan speed control is supplied as standard, because these electronic fans are already equipped with an integrated fan speed control (fan speed range : 50 to 1200 rpm; ambient temperature limit : -18 °C (in cooling mode only)).

Refrigerant circuit

All the units are composed of two independent and separate refrigerant circuits.

Each refrigerant circuit is equipped with liquid line and discharge line shut-off valves, filter-drier with solid core, sight glass and [electronic expansion valve \(EXV\)](#).

The heat pump units (VLH) are provided with 4-way reversing valves, suction accumulators and liquid receivers on the liquid lines.

The functional diagram of each circuit is shown in the section "Refrigerant flow diagram".

Electrical board

Metal case, externally arranged at one end of the unit. Case for the board with IP54 protection rating, complete with grille for natural air ventilation of the box.

Safety and control devices

Each unit is complete with the following safety and control devices:

- Safety
 - Power disconnect switch with an emergency stop function
 - HP switches (double on each circuit of sizes 1004 to 1204), set to 40.5 bar, automatic and manual reset to be reinitialized from the control panel
 - Water differential pressure switch on the evaporator, set to 105 mbar (corresponding to about 50 % of the nominal capacity)
 - Antifreeze temperature sensor (set to +4 °C) on the evaporator
 - Safety valve on discharge lines (for each evaporator), set to 45 bar

- Control
 - HP and LP transducers (two for each circuit)
 - Evaporator water inlet temperature sensor
 - Evaporator water outlet temperature sensor (with an antifreeze function)
 - Suction temperature sensor for EXV control
 - Ambient air temperature sensor
 - Coil temperature sensors

Electronic control

The units are supplied with the new microprocessor-based electronic control and management system ensuring the following functions:

- Management of the operation of compressors:
 - a) Power on/off
 - b) Anticycle management
 - c) Tandem unloading for high pressure or high compressor pressure ratio (integrated inside the curves of compressor operating limits).
- Chilled and hot water temperature regulation (control option on inlet water temperature RWT (P+I type) or outlet water temperature LWT (neutral band type) of the evaporator)
- Control of superheating on suction line
- Evaporator antifreeze protection
- Heat pump defrost control for automatic operation
- Management of high and low pressure alarms
- Management of the electronic expansion valves by means of EXV controller allowing optimized functions : cooling, heating, start-up and defrost
- Management of external interlocks
- Management of the remote control:
 - d) Unit power on/off
 - e) Summary alarm signals
- Remote signalling, by dry contacts:
 - f) Voltage presence
 - g) Compressors in operation
 - h) Alarm, circuit 1
 - i) Alarm, circuit 2
- Management of the hydro kit : start-up of pump, anti-freeze heater of external tank
- Management of the heat recovery mode by means of inlet water temperature sensor at the heat recovery condenser.

The unit controller can also clearly show all control parameters of the machine on the liquid crystal display, such as:

- Display of superheating value
- Display of the temperature at the evaporator inlet and outlet
- Display of the ambient air temperature
- Display of the circuit 1 and circuit 2 discharge pressure and suction pressure
- Display of the set point
- Display of the various alarm and operation status:

- j) Compressor start-up alarm (discharge pressure check)
- k) Low / High pressure
- l) Low / High super-heating
- m) Evaporator antifreeze
- n) Flow switch signal for lack of water
- o) Control of the compressor operating hours
- p) Compressors in operation
- q) Pump in operation and operating hours
- r) Thermal protection of compressors
- s) Thermal protection of fans
- t) Faulty sensors

Standard equipment

- Set point timer/clock card
- Temperature actuated fan speed control
- Back light display
- Digital pressure and temperature reading kit
- High ambient pressure control
- Double set point
- Sequence phase control
- Electronic expansion valves
- Control circuit transformer 400 V/230 V
- Data logger
- Power supply without neutral
- Hour meter
- Main switch
- Refrigerant R410A
- PED approval
- Evaporator antifreeze electric heater
- Compressor jacket (S version only)
- Compressor box
- Water pump acoustic box (S version only)
- Rubber anti-vibration pad
- Water differential pressure switch
- Antifreeze electric heater for hydraulic manifolds (brine application).

Optional hydro kits

On board (mounted inside or outside the unit) and remote hydrokits are available as optional.

The on board hydro kits can be supplied with or without buffer tank while remote hydro kits (supplied loose for field installation) are always provided with internal tank.

1) The on board hydro kit without buffer tank has the following components:

- Single or double pump with low static pressure (100 kPa) or high static pressure (200 kPa)
- Expansion tank (24 litres for all models)
- Water filter (supplied loose)
- Shut-off valves
- Safety valve
- Automatic air vent valve
- Thermal insulation for pipes and water pump(s)

The hydro kit with single pump is fitted inside the unit, whereas the one with double pump is fitted on the back of the unit.

The water pump(s) is supplied with sound-proof box for VLH units in S version.

2) The on board hydro kit with buffer tank has the following components:

- Single or double pump with low static pressure (100 kPa) or high static pressure (200 kPa)
- Buffer tank (500 litres)
- Expansion tank (24 litres for all models)
- Water filter (supplied loose)
- Shut-off valves
- Safety valve
- Automatic air vent valve
- Thermal insulation for pipes and water pump(s)
- Electrical box
- Antifreeze electric heater inside buffer tank (electric heater for pipes is not supplied)

This hydro kit with 500 litres tank and above components, all located in a metallic cabinet, is fitted on the back of the unit; which implies an increase in unit length of about 900 mm.

Factory installed options

- ModBus protocol kit for BMS
- Lonwork protocol kit for BMS
- Bacnet protocol kit for BMS
- Compressors soft starter
- Pressure actuated stepless fan speed controller for low ambient operation (-18 °C)
- Power factor correction capacitors
- Compressors overload protection
- GSM
- HP & LP manometers
- Condenser coils with blue fins treatment
- Condenser coils with "Fin Guard Silver" (polyurethane) treatment
- Condenser coils with copper fins
- Chiller grilles
- Desuperheater
- On board hydro kits without buffer tank
- On board hydro kits with 500 litres buffer tank
- On board hydro kits with 500 litres buffer tank, but without pumps

Field installed accessories

- Remote ON/OFF control
- Remote keyboard panel
- Spring anti-vibration mounts for basic unit
- Spring anti-vibration mounts for unit with copper fins

- Spring anti-vibration mounts for on board hydro kit with tank
- Spring anti-vibration mounts for remote hydro kit
- Flow switch
- Water filter
- Remote hydro kits with buffer tank, 1 or 2 low or high pressure pump(s), relevant accessories and with or without antifreeze heater
 - 750 litres : sizes 704 to 904
 - 1000 litres : sizes 1004 to 1204.

Refrigerant Flow Diagram - VLH Units

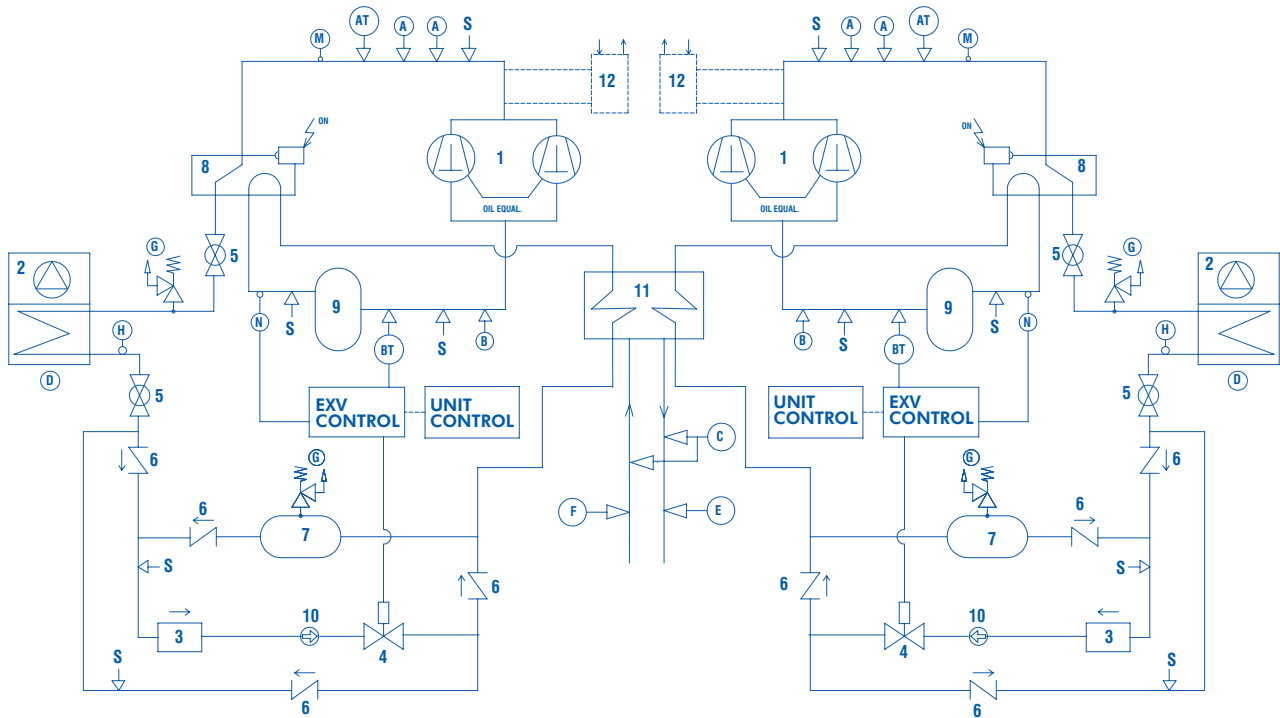

COMPONENTS

- 1 Tandem Scroll type compressor
- 2 Air cooled condenser
- 3 Filter drier
- 4 Electronic expansion valve
- 5 Globe valve
- 6 Check valve
- 7 Liquid receiver
- 8 Four-way valve
- 9 Suction accumulator
- 10 Sight glass
- 11 Heat exchanger (dual type)
- 12 Desuperheater (option)

SAFETY/CONTROL DEVICES

- A High pressure switch
- AT High pressure transducer
- B Low pressure switch
- BT Low pressure transducer
- C Water differential pressure switch
- D Air temperature sensor
- E Outlet water temperature sensor
- F Inlet water temperature sensor
- G PED pressure relief valve
- H Defrost temperature sensor
- M Discharge temperature sensor
- N Suction temperature sensor
- S 5/16" valve connection (service only)
- ↓ Pipe connection with Schrader valve

Operating Limits - VLH Units

Operating limits

VLH 704-904				704		804		904		
				Min	Max	Min	Max	Min	Max	
Chiller	Liquid outlet temperature	Water outlet	°C	from +6 to +15						
		Brine outlet	°C	from -8 to +15						
		ΔT	K	from +3 to +8						
	Flow rate ¹		l/h	19.017	50.711	22.360	59.627	24.607	65.618	
	Pressure drop ¹		kPa	18,5	131,8	21,0	149,4	9,0	64,0	
Max. operating pressure - Water side				bar						10
Heat Pump		Water outlet	°C	from +30 to +50						
Ambient air	Air entering temperature	Cooling - BLN	°C	from -5 to +47 ³		from -0 to +46 ³		from 0 to +47 ³		
		Cooling - LN/ELN	°C	from -5 to +45 ³		from -0 to +44 ³		from 0 to +45 ³		
		Cooling - HT	°C	from -18 to +49 ³		from -18 to +48 ³		from -18 to +49 ³		
		Heating ³	°C	from -10 to +20						
	External static pressure	Standard fans	Pa	0						
Special inverter fans		Pa	≤120							
Recommended system chilled water volume ²			l	550		620		700		
Minimum capacity step			%	20		25		28		
Power supply voltage ⁴			V/ph/Hz	400/3/50						

¹ Total unit flow rate and pressure are given for BLN units.

Caution : Minimum flow rates may only be used with brine solutions after reprogramming the unit parameters.

² Minimum water/brine volume of system (about 3 litres/kW).

³ Max. leaving water temperature = 40 °C at -10 °C in fully loaded conditions and leaving water temperature = 45 °C in part loaded conditions.

⁴ Voltage : 400 V ± 10 %

Operating limits

VLH 1004-1204				1004		1104		1204		
				Min	Max	Min	Max	Min	Max	
Chiller	Liquid outlet temperature	Water outlet	°C	from +6 to +15						
		Brine outlet	°C	from -8 to +15						
		ΔT	K	from +3 to +8						
	Flow rate ¹		l/h	27.219	72.584	30.057	80.152	33.078	88.207	
	Pressure drop ¹		kPa	11,0	78,4	13,4	95,5	16,3	115,7	
Max. operating pressure - Water side				bar						10
Heat Pump		Water outlet	°C	from +30 to +50						
Ambient air	Air entering temperature	Cooling - BLN	°C	from 0 to +46 ³		from 0 to +45 ³		from 0 to +45 ³		
		Cooling - LN/ELN	°C	from 0 to +44 ³		from 0 to +42 ³		from 0 to +42 ³		
		Cooling - HT	°C	from -18 to +48 ³		from -18 to +47 ³		from -18 to +47 ³		
		Heating ³	°C	from -10 to +20						
	External static pressure	Standard fans	Pa	0						
Special inverter fans		Pa	≤120							
Recommended system chilled water volume ²			l	790		870		940		
Minimum capacity step			%	25		23		25		
Power supply voltage ⁴			V/ph/Hz	400/3/50						

¹ Total unit flow rate and pressure are given for BLN units.

Caution : Minimum flow rates may only be used with brine solutions after reprogramming the unit parameters.

² Minimum water/brine volume of system (about 3 litres/kW).

³ Max. leaving water temperature = 40 °C at -10 °C in fully loaded conditions and leaving water temperature = 45 °C in part loaded conditions.

⁴ Voltage : 400 V ± 10 %

Correction Factors

Fouling factors

EVAPORATOR			CONDENSER		
Fouling factor (m ² .°C/kW)	Cooling capacity factor	Power input factor	Fouling factor (m ² .°C/kW)	Cooling capacity factor	Power input factor
0.044	1.000	1.000	0.044	1.000	1.000
0.088	0.987	0.995	0.088	0.987	1.023
0.176	0.964	0.985	0.176	0.955	1.068
0.352	0.915	0.962	0.352	0.910	1.135

Altitude factors

Altitude (m)	Cooling capacity factor	Power input factor
0	1.000	1.000
600	0.987	1.010
1200	0.973	1.020
1800	0.958	1.029
2400	0.943	1.038

System Water Volume

The minimum system water volume is calculated using the [minimum compressor running time](#) (1.5 minute for scroll compressor) and the [lower capacity step](#) (only one compressor running among the four compressors installed):

$$V = \frac{P \times t}{(n \times 25 \times \Delta T)}$$

Where

- V : Water volume (litre)
- P : Unit total cooling capacity (W)
- n : Number of compressor steps
- t : Compressor minimum running time (minute)
- ΔT : Evaporator temperature difference (°C)

With t = 1.5 minute, ΔT = 5 °C and n = 4, the minimum system water volume is about V = 3 litres/kW.

Physical Data - VLH STD/HSE/HPF-STD versions

VLH STD/HSE/HPF-STD models		704	804	904	1004	1104	1204
Nominal cooling capacity (1)	kW	173,2	197,1	226,4	246,3	273,1	299,9
Input power (1)	kW	66,1	72,2	82,6	86,7	99,7	114,0
EER/ Energy efficiency class (1)		2,62/D	2,73/C	2,74/C	2,84/C	2,74/C	2,63/D
SEER (3)		3,63	3,55	3,35	3,50	3,53	3,43
η_{sc} (3)		142	139	131	137	138	134
SEER HSE(3)(*)		3,95	3,83	3,65	3,80	3,78	3,68
η_{sc} HSE (3)(*)		155	150	143	149	148	144
Nominal heating capacity (2)	kW	200,1	223,2	254,7	270,8	302,1	337,4
Input power (2)	kW	67,4	70,4	79,6	87,6	100,0	112,5
COP (2)		2,97	3,17	3,20	3,09	3,02	3,00
SCOP (4)		3,41	3,42	3,28	3,39	3,30	3,19
η_{sh} (4)		133	134	128	133	129	125
SCOP HSE (4)(*)		3,44	3,40	3,32	3,33	3,37	3,30
Number of refrigerant circuits		2	2	2	2	2	2
Total capacity steps	%	20-50-70-100	25-50-75-100	28-50-78-100	25-50-75-100	23-50-73-100	25-50-75-100
COMPRESSORS							
Number		4	4	4	4	4	4
Type		SCROLL					
Oil type		POE					
N° of loading stages		0/100	0/100	0/100	0/100	0/100	0/100
EVAPORATOR							
Number		1	1	1	1	1	1
Type		PLATE	PLATE	PLATE	PLATE	PLATE	PLATE
Water volume	litres	11,5	13,3	25,2	25,2	25,2	25,2
AIR COOLED CONDENSERS							
Number of coils		2	2	2	2	2	2
Total coil face area per coil	m ²	4,8	4,8	4,8	4,8	4,8	4,8
FANS							
Number of fans		3	3	4	4	4	4
Nominal speed	rpm	900	900	900	900	900	900
Total airflow	m ³ /h	68300	68300	85000	80000	75500	75500
Total input power	kW	5,7	5,7	7,6	7,6	7,6	7,6
Total input power HSE(*)	kW	4,0	4,0	5,3	5,3	5,3	5,3
External static pressure	Pa	0 or 120 Pa (**)					
WEIGHT							
Shipping weight	kg	1663	1806	1955	2100	2190	2200
Operating weight	kg	1675	1820	1980	2125	2215	2225
ADDITIONAL WEIGHT							
HSE/HPF versions	kg	30	30	40	40	40	40
Desuperheater versions	kg	20	30	30	30	30	30
With one pump	kg	85	85	90	90	95	95
With two pumps	kg	200	200	205	205	215	215
Copper fins	kg	520	520	520	700	880	880
SOUND LEVELS							
Sound power level (5)	dB(A)	93	93	94	94	95	95
Sound pressure level - (10m) (6)	dB(A)	61	61	62	62	63	63
DIMENSIONS							
Length	mm	4300	4300	4300	4300	4300	4300
Width	mm	1100	1100	1100	1100	1100	1100
Height	mm	2300	2300	2300	2300	2300	2300

(1) Data based on 7 °C leaving chilled water temperature and 35 °C ambient air temperature.

(2) Data based on 45 °C leaving hot water temperature and 7 °C ambient air temperature with 88 % relative humidity.

(3) According EN14825.

(4) According EN14825 and following COMMISSION REGULATION (EU) No 813/2013.

(5) Sound levels are at fully loaded conditions. Sound power level values refer to ISO standard 3744 and Eurovent 8/1.

(6) Sound pressure level values refer to ISO standard 3744, parallelepiped shape.

(*) High efficiency units (HSE) with inverter fans.

(**) HPF units with high static pressure fans.

Physical Data - VLH STD/HSE- L versions

VLH STD/HSE-L models		704	804	904	1004	1104	1204
Nominal cooling capacity (1)	kW	168,2	191,2	220,4	237,3	261,2	285,1
Input power (1)	kW	66,2	73,3	83,8	88,5	102,8	119,8
EER/ Energy efficiency class (1)		2,54/D	2,61/D	2,63/D	2,68/D	2,54/D	2,38/E
SEER (3)		3,0	3,0	3,1	3,28	3,3	3,23
η_{sc} (3)		117	117	121	128	129	126
SEER HSE(3)(*)		3,95	3,83	3,65	3,8	3,78	3,68
η_{sc} HSE (3)(*)		155	150	143	149	148	144
Nominal heating capacity (2)	kW	195,0	217,1	247,7	261,8	288,9	322,2
Input power (2)	kW	65,2	68,3	76,9	84,7	97,0	109,2
COP (2)		2,99	3,18	3,22	3,09	2,98	2,95
SCOP (4)		3,41	3,42	3,28	3,39	3,20	3,19
η_{sh} (4)		133	134	128	133	125	125
SCOP HSE (4)(*)		3,44	3,4	3,32	3,33	3,37	3,24
Number of refrigerant circuits		2	2	2	2	2	2
Total capacity steps	%	20-50-70-100	25-50-75-100	28-50-78-100	25-50-75-100	23-50-73-100	25-50-75-100
COMPRESSORS							
Number		4	4	4	4	4	4
Type		SCROLL					
Oil type		POE					
N° of loading stages		0/100	0/100	0/100	0/100	0/100	0/100
EVAPORATOR							
Number		1	1	1	1	1	1
Type		PLATE	PLATE	PLATE	PLATE	PLATE	PLATE
Water volume	litres	11,5	13,3	25,2	25,2	25,2	25,2
AIR COOLED CONDENSERS							
Number of coils		2	2	2	2	2	2
Total coil face area per coil	m ²	4,8	4,8	4,8	4,8	4,8	4,8
FANS							
Number of fans		3	3	4	4	4	4
Nominal speed	rpm	700	700	700	700	700	700
Total airflow	m ³ /h	52200	52200	63700	58800	54900	54900
Total input power	kW	3,6	3,6	4,8	4,8	4,8	4,8
Total input power HSE (*)	kW	1,9	1,9	2,5	2,5	2,5	2,5
External static pressure	Pa	0					
WEIGHT							
Shipping weight	kg	1663	1806	1955	2100	2190	2200
Operating weight	kg	1675	1820	1980	2125	2215	2225
ADDITIONAL WEIGHT							
HSE versions	kg	30	30	40	40	40	40
Desuperheater versions	kg	20	30	30	30	30	30
With one pump	kg	85	85	90	90	95	95
With two pumps	kg	200	200	205	205	215	215
Copper fins	kg	520	520	520	700	880	880
SOUND LEVELS							
Sound power level (5)	dB(A)	87	87	88	88	89	89
Sound pressure level - (10m) (6)	dB(A)	55	55	56	56	57	57
DIMENSIONS							
Length	mm	4300	4300	4300	4300	4300	4300
Width	mm	1100	1100	1100	1100	1100	1100
Height	mm	2300	2300	2300	2300	2300	2300

(1) Data based on 7 °C leaving chilled water temperature and 35 °C ambient air temperature.

(2) Data based on 45 °C leaving hot water temperature and 7 °C ambient air temperature with 88 % relative humidity.

(3) According EN14825.

(4) According EN14825 and following COMMISSION REGULATION (EU) No 813/2013.

(5) Sound levels are at fully loaded conditions. Sound power level values refer to ISO standard 3744 and Eurovent 8/1.

(6) Sound pressure level values refer to ISO standard 3744, parallelepiped shape.

(*) High efficiency units (HSE) with inverter fans.

Physical Data - VLH STD/HSE- S versions

VLH STD/HSE-S models		704	804	904	1004	1104	1204
Nominal cooling capacity (1)	kW	164,3	185,2	214,5	230,4	253,3	276,1
Input power (1)	kW	69,0	76,2	86,1	90,7	106,9	124,9
EER/ Energy efficiency class (1)		2,38/E	2,43/E	2,49/E	2,54/D	2,37/E	2,21/F
SEER (3)		3,63	3,55	3,35	3,5	3,53	3,43
η_{sc} (3)		142	139	131	137	138	134
SEER HSE(3)(*)		3,95	3,83	3,65	3,8	3,78	3,68
η_{sc} HSE (3)(*)		155	150	143	149	148	144
Nominal heating capacity (2)	kW	184,9	202,9	232,6	245,7	266,8	297,0
Input power (2)	kW	64,9	67,0	75,8	83,9	95,0	108,0
COP (2)		3,03	3,21	3,27	3,10	2,96	2,87
SCOP (4)		3,41	3,42	3,28	3,39	3,3	3,19
η_{sh} (4)		133	134	128	133	129	125
SCOP HSE (4)(*)		3,44	3,4	3,32	3,33	3,37	3,26
Number of refrigerant circuits		2	2	2	2	2	2
Total capacity steps	%	20-50-70-100	25-50-75-100	28-50-78-100	25-50-75-100	23-50-73-100	25-50-75-100
COMPRESSORS							
Number		4	4	4	4	4	4
Type		SCROLL					
Oil type		POE					
N° of loading stages		0/100	0/100	0/100	0/100	0/100	0/100
EVAPORATOR							
Number		1	1	1	1	1	1
Type		PLATE	PLATE	PLATE	PLATE	PLATE	PLATE
Water volume	litres	11,5	13,3	25,2	25,2	25,2	25,2
AIR COOLED CONDENSERS							
Number of coils		2	2	2	2	2	2
Total coil face area per coil	m ²	4,8	4,8	4,8	4,8	4,8	4,8
FANS							
Number of fans		3	3	4	4	4	4
Nominal speed	rpm	550	550	550	550	550	550
Total airflow	m ³ /h	41800	41800	52000	48900	46200	46200
Total input power	kW	3	3	4	4	4	4
Total input power HSE (*)	kW	0,9	0,9	1,2	1,2	1,2	1,2
External static pressure	Pa	0					
WEIGHT							
Shipping weight	kg	1698	1841	1990	2140	2230	2240
Operating weight	kg	1710	1855	2015	2165	2255	2265
ADDITIONAL WEIGHT							
HSE versions	kg	30	30	40	40	40	40
Desuperheater versions	kg	20	30	30	30	30	30
With one pump	kg	85	85	90	90	95	95
With two pumps	kg	200	200	205	205	215	215
Copper fins	kg	520	520	520	700	880	880
SOUND LEVELS							
Sound power level (5)	dB(A)	83	83	84	84	85	85
Sound pressure level - (10m) (6)	dB(A)	51	51	52	52	53	53
DIMENSIONS							
Length	mm	4300	4300	4300	4300	4300	4300
Width	mm	1100	1100	1100	1100	1100	1100
Height	mm	2300	2300	2300	2300	2300	2300

(1) Data based on 7 °C leaving chilled water temperature and 35 °C ambient air temperature.

(2) Data based on 45 °C leaving hot water temperature and 7 °C ambient air temperature with 88 % relative humidity.

(3) According EN14825.

(4) According EN14825 and following COMMISSION REGULATION (EU) No 813/2013.

(5) Sound levels are at fully loaded conditions. Sound power level values refer to ISO standard 3744 and Eurovent 8/1.

(6) Sound pressure level values refer to ISO standard 3744, parallelepiped shape.

(*) High efficiency units (HSE) with inverter fans.

Physical Data - VLH HT versions

VLH HT models		704	804	904	1004	1104	1204
Nominal cooling capacity (1)	kW	175,6	199,7	229,5	250,1	276,5	305,6
Input power (1)	kW	58,4	64,4	73,2	76,8	89,9	102,8
EER/ Energy efficiency class (1)		2,64/D	2,75/D	2,74/D	2,85/D	2,73/D	2,67/D
SEER (3)		3	3	3,1	3,28	3,3	3,23
η_{sc} (3)		117	117	121	128	129	126
Nominal heating capacity (2)	kW	200,7	224,0	256,6	273,7	305,5	341,5
Input power (2)	kW	60,6	63,5	71,4	79,3	91,4	103,5
COP (2)		2,97	3,18	3,17	3,07	3,01	3,01
SCOP (4)		3,44	3,4	3,32	3,33	3,37	3,26
η_{sh} (4)		135	133	130	130	132	127
Number of refrigerant circuits		2	2	2	2	2	2
Total capacity steps	%	20-50-70-100	25-50-75-100	28-50-78-100	25-50-75-100	23-50-73-100	25-50-75-100
COMPRESSORS							
Number		4	4	4	4	4	4
Type		SCROLL					
Oil type		POE					
N° of loading stages		0/100	0/100	0/100	0/100	0/100	0/100
EVAPORATOR							
Number		1	1	1	1	1	1
Type		PLATE	PLATE	PLATE	PLATE	PLATE	PLATE
Water volume	litres	11,5	13,3	25,2	25,2	25,2	25,2
AIR COOLED CONDENSERS							
Number of coils		2	2	2	2	2	2
Total coil face area per coil	m ²	4,8	4,8	4,8	4,8	4,8	4,8
FANS							
Number of fans		3	3	4	4	4	4
Nominal speed	rpm	1110	1110	1110	1110	1110	1110
Total airflow	m ³ /h	76200	76200	95800	91200	87600	87600
Total input power HSE (*)	kW	6,9	6,9	9,6	9,9	10	10
External static pressure	Pa	0					
WEIGHT							
Shipping weight	kg	1693	1836	1995	2140	2230	2240
Operating weight	kg	1705	1850	2020	2165	2255	2265
ADDITIONAL WEIGHT							
Desuperheater versions	kg	20	30	30	30	30	30
With one pump	kg	85	85	90	90	95	95
With two pumps	kg	200	200	205	205	215	215
Copper fins	kg	520	520	520	700	880	880
SOUND LEVELS							
Sound power level (5)	dB(A)	99	99	100	100	100	100
Sound pressure level - (10m) (6)	dB(A)	67	67	68	68	68	68
DIMENSIONS							
Length	mm	4300	4300	4300	4300	4300	4300
Width	mm	1100	1100	1100	1100	1100	1100
Height	mm	2300	2300	2300	2300	2300	2300

(1) Data based on 7 °C leaving chilled water temperature and 35 °C ambient air temperature.

(2) Data based on 45 °C leaving hot water temperature and 7 °C ambient air temperature with 88 % relative humidity.

(3) According EN14825.

(4) According EN14825 and following COMMISSION REGULATION (EU) No 813/2013.

(5) Sound levels are at fully loaded conditions. Sound power level values refer to ISO standard 3744 and Eurovent 8/1.

(6) Sound pressure level values refer to ISO standard 3744, parallelepiped shape.

(*) High efficiency units (HSE) with inverter fans.

Electrical Data - VLH STD Units

Compressors @ 400 V / 3 ph / 50 Hz

Models		Power input at nominal conditions per compressor (kW)	Current at nominal conditions per compressor (A)	Power input at max. conditions per compressor (kW)	Current at max. conditions per compressor FLA (A)	Start up current LRA (A)	Power factor at nominal conditions	Unit fuse size (A)	Cable section (mm ²)
704	Circuit 1	12.3	24	17.0	34	174	0.75	250	3 x 120
		15.5	26	21.6	36.7	240	0.87		
	Circuit 2	12.3	24	17.0	34	174	0.75		
		15.5	26	21.6	36.7	240	0.87		
804	Circuit 1	15.5	26	21.6	36.7	240	0.87	250	3 x 120
		15.5	26	21.6	36.7	240	0.87		
	Circuit 2	15.5	26	21.6	36.7	240	0.87		
		15.5	26	21.6	36.7	240	0.87		
904	Circuit 1	15.5	26	21.6	36.7	240	0.87	250	3 x 120
		19.3	34	27.1	48.7	287	0.83		
	Circuit 2	15.5	26	21.6	36.7	240	0.87		
		19.3	34	27.1	48.7	287	0.83		
1004	Circuit 1	19.3	34	27.1	48.7	287	0.83	250	3 x 120
		19.3	34	27.1	48.7	287	0.83		
	Circuit 2	19.3	34	27.1	48.7	287	0.83		
		19.3	34	27.1	48.7	287	0.83		
1104	Circuit 1	19.3	34	27.1	48.7	287	0.83	315	3 x 185
		25.6	44	36.0	65.4	310	0.84		
	Circuit 2	19.3	34	27.1	48.7	287	0.82		
		25.6	44	36.0	65.4	310	0.84		
1204	Circuit 1	25.6	44	36.0	65.4	310	0.84	315	3 x 185
		25.6	44	36.0	65.4	310	0.84		
	Circuit 2	25.6	44	36.0	65.4	310	0.84		
		25.6	44	36.0	65.4	310	0.84		

Note : The dimensioning of the unit's power cables is the responsibility of the installer, who shall consider : the rating, the maximum working temperature in the room, the type of insulation and the cable laying, the maximum length of the power supply line.

Fans @ 400 V / 3 ph / 50 Hz

VLH STD models		704	804	904	1004	1104	1204
Number of fans		3	3	4	4	4	4
Nominal power per fan	kW	2.0	2.0	2.0	2.0	2.0	2.0
Max. running current per fan	A	4.0	4.0	4.0	4.0	4.0	4.0
Total fan power	kW	6.0	6.0	8.0	8.0	8.0	8.0
Total max. fan current	A	12.0	12.0	16.0	16.0	16.0	16.0

VLH L models		704	804	904	1004	1104	1204
Number of fans		3	3	4	4	4	4
Nominal power per fan	kW	1.25	1.25	1.25	1.25	1.25	1.25
Max. running current per fan	A	2.3	2.3	2.3	2.3	2.3	2.3
Total fan power	kW	3.8	3.8	5.0	5.0	5.0	5.0
Total max. fan current	A	6.9	6.9	9.2	9.2	9.2	9.2

Electrical Data - VLH STD Units (continued)

Fans @ 400 V / 3 ph / 50 Hz

VLH S models		704	804	904	1004	1104	1204
Number of fans		3	3	4	4	4	4
Nominal power per fan	kW	1.25	1.25	1.25	1.25	1.25	1.25
Max. running current per fan	A	2.3	2.3	2.3	2.3	2.3	2.3
Total fan power	kW	3.8	3.8	5.0	5.0	5.0	5.0
Total max. fan current	A	6.9	6.9	9.2	9.2	9.2	9.2

Units @ 400 V / 3 ph / 50 Hz

VLH STD models		704	804	904	1004	1104	1204
Nominal power input	kW	61.2	67.7	77.2	84.8	97.4	110.0
Maximum power input	kW	82.8	92.1	105.0	116.0	133.8	151.6
Nominal current input	A	111.8	114.1	134.2	150.4	170.9	191.4
Maximum current input	A	153.1	158.5	186.4	210.4	243.8	277.2
Start-up current	A	356	362	425	449	488	522

VLH L models		704	804	904	1004	1104	1204
Nominal power input	kW	61.2	67.7	77.2	84.8	97.4	110.0
Maximum power input	kW	82.8	92.1	105.0	116.0	133.8	151.6
Nominal current input	A	111.8	114.1	134.2	150.4	170.9	191.4
Maximum current input	A	153.1	158.5	186.4	210.4	243.8	277.2
Start-up current	A	356	362	425	437	488	522

VLH S models		704	804	904	1004	1104	1204
Nominal power input	kW	61.2	67.7	77.2	84.8	97.4	110.0
Maximum power input	kW	82.8	92.1	105.0	116.0	133.8	151.6
Nominal current input	A	111.8	114.1	134.2	150.4	170.9	191.4
Maximum current input	A	153.1	158.5	186.4	210.4	243.8	277.2
Start-up current	A	356	362	425	437	488	522

Electrical Data - VLH HSE/HPF/HT Units

Compressors @ 400 V / 3 ph / 50 Hz

Models		Power input at nominal conditions per compressor (kW)	Current at nominal conditions per compressor (A)	Power input at max. conditions per compressor (kW)	Current at max. conditions per compressor FLA (A)	Start up current LRA (A)	Power factor at nominal conditions	Unit fuse size (A)	Cable section (mm ²)
704	Circuit 1	12.3	24	17.0	34	174	0.75	250	3 x 120
		15.5	26	21.6	36.7	240	0.87		
	Circuit 2	12.3	24	17.0	34	174	0.75		
		15.5	26	21.6	36.7	240	0.87		
804	Circuit 1	15.5	26	21.6	36.7	240	0.87	250	3 x 120
		15.5	26	21.6	36.7	240	0.87		
	Circuit 2	15.5	26	21.6	36.7	240	0.87		
		15.5	26	21.6	36.7	240	0.87		
904	Circuit 1	15.5	26	21.6	36.7	240	0.87	250	3 x 120
		19.3	34	27.1	48.7	287	0.83		
	Circuit 2	15.5	26	21.6	36.7	240	0.87		
		19.3	34	27.1	48.7	287	0.83		
1004	Circuit 1	19.3	34	27.1	48.7	287	0.83	250	3 x 120
		19.3	34	27.1	48.7	287	0.83		
	Circuit 2	19.3	34	27.1	48.7	287	0.83		
		19.3	34	27.1	48.7	287	0.83		
1104	Circuit 1	19.3	34	27.1	48.7	287	0.83	315	3 x 185
		25.6	44	36.0	65.4	310	0.84		
	Circuit 2	19.3	34	27.1	48.7	287	0.82		
		25.6	44	36.0	65.4	310	0.84		
1204	Circuit 1	25.6	44	36.0	65.4	310	0.84	315	3 x 185
		25.6	44	36.0	65.4	310	0.84		
	Circuit 2	25.6	44	36.0	65.4	310	0.84		
		25.6	44	36.0	65.4	310	0.84		

Note : The dimensioning of the unit's power cables is the responsibility of the installer, who shall consider : the rating, the maximum working temperature in the room, the type of insulation and the cable laying, the maximum length of the power supply line.

Fans @ 400 V / 3 ph / 50 Hz

VLH STD models		704	804	904	1004	1104	1204
Number of fans		3	3	4	4	4	4
Nominal power per fan	kW	2.6	2.6	2.6	2.6	2.6	2.6
Max. running current per fan	A	4.1	4.1	4.1	4.1	4.1	4.1
Total fan power	kW	7.8	7.8	10.4	10.4	10.4	10.4
Total max. fan current	A	12.3	12.3	16.4	16.4	16.4	16.4

VLH L models		704	804	904	1004	1104	1204
Number of fans		3	3	4	4	4	4
Nominal power per fan	kW	2.6	2.6	2.6	2.6	2.6	2.6
Max. running current per fan	A	4.1	4.1	4.1	4.1	4.1	4.1
Total fan power	kW	7.8	7.8	10.4	10.4	10.4	10.4
Total max. fan current	A	12.3	12.3	16.4	16.4	16.4	16.4

Electrical Data - VLH HSE/HPF/HT Units (continued)

Fans @ 400 V / 3 ph / 50 Hz

VLH S models		704	804	904	1004	1104	1204
Number of fans		3	3	4	4	4	4
Nominal power per fan	kW	2.6	2.6	2.6	2.6	2.6	2.6
Max. running current per fan	A	4.1	4.1	4.1	4.1	4.1	4.1
Total fan power	kW	7.8	7.8	10.4	10.4	10.4	10.4
Total max. fan current	A	12.3	12.3	16.4	16.4	16.4	16.4

Units @ 400 V / 3 ph / 50 Hz

VLH STD models		704	804	904	1004	1104	1204
Nominal power input	kW	64.8	71.3	82.0	89.6	102.2	114.8
Maximum power input	kW	86.4	95.7	109.8	120.8	138.6	156.4
Nominal current input	A	114.5	116.8	137.8	154.0	174.5	195.0
Maximum current input	A	155.8	161.2	190.0	214.0	247.4	280.8
Start-up current	A	359	365	428	452	492	525

VLH L models		704	804	904	1004	1104	1204
Nominal power input	kW	64.8	71.3	82.0	89.6	102.2	114.8
Maximum power input	kW	86.4	95.7	109.8	120.8	138.6	156.4
Nominal current input	A	114.5	116.8	137.8	154.0	174.5	195.0
Maximum current input	A	155.8	161.2	190.0	214.0	247.4	280.8
Start-up current	A	359	365	428	452	492	525

VLH S models		704	804	904	1004	1104	1204
Nominal power input	kW	64.8	71.3	82.0	89.6	102.2	114.8
Maximum power input	kW	86.4	95.7	109.8	120.8	138.6	156.4
Nominal current input	A	114.5	116.8	137.8	154.0	174.5	195.0
Maximum current input	A	155.8	161.2	190.0	214.0	247.4	280.8
Start-up current	A	359	365	428	452	492	525

Fan Data - HPF Version

Sizes	Fan static pressure [Pa]	Fan rpm	Service parameter Max speed (Vdc)
704	45	900	6.8
	75	950	7.3
	100*	1000	7.8
	130	1050	8.3
	160	1100	8.9
804	45	900	6.8
	75	950	7.3
	100*	1000	7.8
	130	1050	8.3
	160	1100	8.9
904	50	900	6.8
	80	950	7.3
	105*	1000	7.8
	130	1050	8.3
	160	1100	8.9
1004	55	900	6.8
	80	950	7.3
	105*	1000	7.8
	130	1050	8.3
	160	1100	8.9
1104	60	900	6.8
	85	950	7.3
	105*	1000	7.8
	130	1050	8.3
	160	1100	8.9
1204	60	900	6.8
	85	950	7.3
	105*	1000	7.8
	130	1050	8.3
	160	1100	8.9

Note : Values in bold type are standard factory setting.

Sound Levels - VLH Units

Models		Frequency (Hz)							Sound Power dB(A)	Sound Pressure dB(A)(*)
		125	250	500	1000	2000	4000	8000		
VLH STD	704	87.0	86.0	94.0	88.0	82.0	67.0	55.0	93	61
	804	87.0	86.0	94.0	88.0	82.0	67.0	55.0	93	61
	904	88.0	87.0	95.0	89.0	83.0	68.0	56.0	94	62
	1004	88.0	87.0	95.0	89.0	83.0	68.0	56.0	94	62
	1104	89.0	88.0	96.0	90.0	84.0	69.0	57.0	95	63
	1204	89.0	88.0	96.0	90.0	84.0	69.0	57.0	95	63
VLH L	704	81.0	80.0	88.0	82.0	76.0	61.0	49.0	87	55
	804	81.0	80.0	88.0	82.0	76.0	61.0	49.0	87	55
	904	82.0	81.0	89.0	83.0	77.0	62.0	50.0	88	56
	1004	82.0	81.0	89.0	83.0	77.0	62.0	50.0	88	56
	1104	83.0	82.0	90.0	84.0	78.0	63.0	51.0	89	57
	1204	83.0	82.0	90.0	84.0	78.0	63.0	51.0	89	57
VLH S	704	77.0	76.0	84.0	78.0	72.0	57.0	45.0	83	51
	804	77.0	76.0	84.0	78.0	72.0	57.0	45.0	83	51
	904	78.0	77.0	85.0	79.0	73.0	58.0	46.0	84	52
	1004	78.0	77.0	85.0	79.0	73.0	58.0	46.0	84	52
	1104	79.0	78.0	86.0	80.0	74.0	59.0	47.0	85	53
	1204	79.0	78.0	86.0	80.0	74.0	59.0	47.0	85	53
VLH HT (**)	704	93.0	92.0	100.0	94.0	88.0	73.0	61.0	99	67
	804	93.0	92.0	100.0	94.0	88.0	73.0	61.0	99	67
	904	94.0	93.0	101.0	95.0	89.0	74.0	62.0	100	68
	1004	94.0	93.0	101.0	95.0	89.0	74.0	62.0	100	68
	1104	94.0	93.0	101.0	95.0	89.0	74.0	62.0	100	68
	1204	94.0	93.0	101.0	95.0	89.0	74.0	62.0	100	68

(*) Sound pressure levels are given at 10 meters distance according to ISO standard 3744 with parallepiped shape.

(**) Sound data is given at maximum operating air temperature. For nominal condition, please refer to sound data of STD version.

Cooling Capacities - VLH STD/HSE/HPF - STD Version

VLH STD/HSE/ HPF models	LWT (°C)	Condenser entering air temperature (°C)													
		25		30		32		35		40		44		46	
		Cooling capacity (kW)	Input power (kW)	Cooling capacity (kW)	Input power (kW)	Cooling capacity (kW)	Input power (kW)	Cooling capacity (kW)	Input power (kW)	Cooling capacity (kW)	Input power (kW)	Cooling capacity (kW)	Input power (kW)	Cooling capacity (kW)	Input power (kW)
704 STD	5	182.3	48.5	173.6	53.2	169.9	55.2	164.2	58.1	152.6	64.6	145.5	68.7	138.4	72.8
	6	187.8	49.0	178.6	53.8	174.9	55.8	169.0	58.8	157.2	65.2	149.8	69.4	142.5	73.6
	7	193.2	49.6	183.9	54.4	179.9	56.4	174.0	59.4	161.7	65.9	154.2	70.1	146.6	74.3
	8	198.1	50.2	188.5	55.0	184.6	57.0	178.4	60.1	165.8	66.5	158.1	70.7	150.3	75.0
	9	203.0	50.8	193.2	55.7	189.0	57.7	182.9	60.7	170.0	67.2	162.1	71.4	154.1	75.6
	10	207.9	51.5	197.8	56.3	193.6	58.4	187.2	61.4	173.9	67.9	165.8	72.1	157.8	76.4
	12	217.8	52.7	207.2	57.7	202.9	59.7	196.1	62.7	182.3	69.4	173.7	73.7	165.2	78.0
15	232.6	54.8	221.5	59.7	216.8	61.7	209.4	64.9	194.8	71.5	185.6	75.9	176.5	80.3	
804 STD	5	207.1	53.5	197.1	58.7	192.9	60.8	186.5	64.1	173.4	71.2	165.3	75.7	157.2	80.3
	6	213.3	54.1	202.8	59.4	198.6	61.5	192.0	64.8	178.5	71.9	170.2	76.5	161.8	81.1
	7	219.4	54.7	208.8	60.0	204.3	62.2	197.6	65.5	183.6	72.7	175.1	77.3	166.5	81.9
	8	224.9	55.4	214.1	60.7	209.6	62.9	202.5	66.2	188.3	73.4	179.5	78.0	170.7	82.6
	9	230.6	56.1	219.4	61.4	214.6	63.6	207.7	66.9	193.1	74.1	184.0	78.8	175.0	83.4
	10	236.1	56.8	224.7	62.1	219.9	64.4	212.6	67.7	197.5	74.9	188.3	79.6	179.2	84.3
	12	247.3	58.2	235.3	63.6	230.4	65.8	222.7	69.2	207.0	76.5	197.3	81.2	187.6	86.0
15	264.2	60.4	251.5	65.8	246.2	68.1	237.8	71.5	221.2	78.9	210.8	83.7	200.4	88.5	
904 STD	5	237.6	60.6	226.1	66.5	221.3	68.9	213.9	72.6	198.9	80.6	189.6	85.8	180.3	90.9
	6	244.7	61.3	232.7	67.3	227.9	69.7	220.2	73.4	204.8	81.5	195.2	86.7	185.6	91.9
	7	251.8	62.0	239.5	68.0	234.4	70.5	226.7	74.2	210.7	82.3	200.9	87.5	191.1	92.8
	8	258.1	62.7	245.6	68.8	240.5	71.3	232.4	75.0	216.1	83.1	206.0	88.4	195.9	93.6
	9	264.5	63.5	251.7	69.6	246.2	72.1	238.3	75.8	221.5	84.0	211.1	89.2	200.8	94.5
	10	270.8	64.3	257.7	70.3	252.3	72.9	244.0	76.7	226.5	84.8	216.0	90.1	205.5	95.4
	12	283.7	65.9	269.9	72.1	264.3	74.6	255.5	78.3	237.5	86.6	226.3	92.0	215.2	97.4
15	303.1	68.4	288.5	74.5	282.4	77.1	272.8	81.0	253.8	89.3	241.9	94.8	229.9	100.3	
1004 STD	5	258.6	64.0	246.2	70.3	240.9	72.8	232.9	76.7	216.5	85.2	206.4	90.6	196.3	96.1
	6	266.4	64.7	253.3	71.1	248.1	73.6	239.8	77.6	223.0	86.1	212.5	91.6	202.1	97.1
	7	274.1	65.5	260.8	71.9	255.2	74.5	246.8	78.4	229.4	87.0	218.7	92.5	208.0	98.0
	8	281.0	66.3	267.4	72.6	261.8	75.3	253.0	79.3	235.2	87.8	224.2	93.4	213.3	98.9
	9	288.0	67.1	274.0	73.5	268.1	76.2	259.4	80.1	241.1	88.7	229.9	94.3	218.6	99.8
	10	294.8	68.0	280.6	74.3	274.6	77.0	265.6	81.0	246.6	89.6	235.2	95.2	223.8	100.9
	12	308.9	69.6	293.9	76.1	287.8	78.8	278.2	82.8	258.5	91.6	246.4	97.2	234.3	102.9
15	329.9	72.3	314.1	78.7	307.5	81.5	297.0	85.6	276.3	94.4	263.3	100.2	250.3	106.0	
1104 STD	5	287.0	74.5	273.2	81.8	267.4	84.8	258.5	89.4	240.3	99.2	229.1	105.6		
	6	295.6	75.4	281.1	82.8	275.3	85.7	266.1	90.4	247.5	100.3	235.9	106.7		
	7	304.2	76.3	289.4	83.7	283.3	86.8	273.9	91.3	254.5	101.3	242.7	107.7		
	8	311.8	77.2	296.8	84.6	290.5	87.7	280.8	92.3	261.1	102.3	248.9	108.7		
	9	319.6	78.1	304.1	85.6	297.5	88.7	287.9	93.2	267.6	103.3	255.1	109.8		
	10	327.2	79.1	311.4	86.5	304.8	89.7	294.7	94.4	273.7	104.3	261.0	110.9		
	12	342.8	81.1	326.1	88.7	319.4	91.7	308.7	96.4	286.9	106.6	273.5	113.2		
15	366.2	84.2	348.6	91.7	341.2	94.9	329.7	99.7	306.6	109.9	292.2	116.7			
1204 STD	5	314.9	86.1	299.8	94.6	293.4	98.0	283.6	103.3	263.6	114.7	251.3	122.0		
	6	324.3	87.1	308.5	95.6	302.1	99.1	291.9	104.4	271.5	115.9	258.8	123.3		
	7	333.7	88.2	317.5	96.7	310.8	100.2	300.5	105.5	279.3	117.1	266.3	124.5		
	8	342.1	89.2	325.6	97.8	318.7	101.3	308.0	106.7	286.4	118.2	273.0	125.6		
	9	350.6	90.3	333.6	98.9	326.4	102.5	315.9	107.7	293.6	119.4	279.9	126.9		
	10	359.0	91.4	341.6	100.0	334.4	103.7	323.4	109.0	300.3	120.6	286.4	128.1		
	12	376.1	93.7	357.8	102.4	350.4	106.0	338.7	111.4	314.8	123.2	300.0	130.9		
15	401.7	97.3	382.4	106.0	374.4	109.6	361.7	115.2	336.4	127.0	320.6	134.8			

Notes : - LWT : Leaving water temperature.
- Power input data are given for compressors only.

Heating Capacities - VLH STD/HSE/HPF - STD Version

VLH STD/HSE/ HPF models	LWT (°C)	Ambient coil entering air temperature (°C)													
		-5		-3		0		5		7		10		15	
		Heating capacity (kW)	Input power (kW)	Heating capacity (kW)	Input power (kW)	Heating capacity (kW)	Input power (kW)	Heating capacity (kW)	Input power (kW)	Heating capacity (kW)	Input power (kW)	Heating capacity (kW)	Input power (kW)	Heating capacity (kW)	Input power (kW)
704 STD	30	152.4	42.1	160.4	42.2	173.3	42.4	196.0	43.0	206.0	43.3	221.9	43.7	251.4	44.4
	35	150.4	49.5	159.8	47.3	172.3	47.4	194.0	48.0	203.6	48.3	218.9	48.7	247.0	49.5
	40	148.6	55.5	158.2	53.0	171.5	53.1	192.2	53.8	201.4	54.0	215.9	54.5	242.6	55.3
	45	147.0	62.4	156.4	59.5	169.5	59.8	190.6	60.3	199.2	60.6	213.1	61.0	238.2	61.9
	50					167.7	67.6	189.6	67.9	197.6	68.2	210.6	68.5	234.1	69.3
804 STD	30	169.8	44.1	178.6	44.3	193.1	44.4	218.3	45.0	229.4	45.3	247.2	45.8	280.0	46.5
	35	167.5	51.9	178.0	49.5	191.9	49.7	216.1	50.3	226.8	50.6	243.9	51.1	275.2	51.9
	40	165.5	58.2	176.2	55.5	191.1	55.7	214.1	56.3	224.3	56.6	240.5	57.1	270.3	57.9
	45	163.8	65.4	174.2	62.4	188.8	62.6	212.4	63.2	221.9	63.5	237.4	63.9	265.4	64.8
	50					186.8	70.8	211.2	71.2	220.1	71.4	234.5	71.8	260.7	72.6
904 STD	30	194.4	49.6	204.6	49.8	221.1	49.9	250.0	50.6	262.7	51.0	283.1	51.5	320.7	52.3
	35	191.8	58.3	203.8	55.7	219.8	55.8	247.5	56.5	259.7	56.9	279.3	57.4	315.1	58.3
	40	189.6	65.4	201.8	62.4	218.8	62.6	245.2	63.3	256.9	63.6	275.4	64.2	309.5	65.1
	45	187.5	73.5	199.5	70.1	216.2	70.4	243.2	71.0	254.1	71.4	271.9	71.9	303.9	72.9
	50					214.0	79.6	241.9	80.0	252.1	80.3	268.6	80.8	298.6	81.7
1004 STD	30	206.6	55.1	217.4	55.3	234.9	55.4	265.7	56.2	279.2	56.6	300.8	57.2	340.7	58.1
	35	203.9	64.8	216.5	61.9	233.6	62.0	263.0	62.8	275.9	63.2	296.7	63.8	334.8	64.8
	40	201.4	72.6	214.4	69.3	232.5	69.5	260.6	70.3	273.0	70.7	292.7	71.3	328.9	72.3
	45	199.3	81.7	212.0	77.9	229.8	78.2	258.4	78.9	270.0	79.3	288.9	79.9	322.9	81.0
	50					227.3	88.4	257.0	88.9	267.8	89.2	285.4	89.7	317.3	90.7
1104 STD	30	230.1	63.5	242.1	63.6	261.7	63.8	296.0	64.7	311.0	65.2	335.1	65.8	379.6	66.9
	35	227.1	74.6	241.2	71.2	260.2	71.4	293.0	72.3	307.4	72.8	330.6	73.4	373.0	74.6
	40	224.4	83.6	238.8	79.8	259.0	80.1	290.3	81.0	304.1	81.3	326.1	82.1	366.4	83.3
	45	222.0	94.0	236.1	89.7	256.0	90.0	287.9	90.8	300.8	91.3	321.9	91.9	359.8	93.2
	50					253.3	101.8	286.4	102.3	298.4	102.7	317.9	103.3	353.4	104.4
1204 STD	30	256.9	71.9	270.3	72.1	292.1	72.3	330.4	73.3	347.2	73.8	374.1	74.6	423.8	75.8
	35	253.5	84.5	269.3	80.7	290.5	80.9	327.1	81.9	343.2	82.4	369.0	83.1	416.4	84.5
	40	250.5	94.7	266.6	90.4	289.1	90.7	324.0	91.7	339.5	92.1	364.0	93.0	409.0	94.3
	45	247.8	106.5	263.6	101.5	285.8	102.0	321.4	102.9	335.8	103.4	359.3	104.1	401.6	105.6
	50					282.7	115.3	319.7	115.9	333.1	116.3	354.9	116.9	394.6	118.3

- Notes :**
- LWT : Leaving water temperature.
 - Power input data are given for compressors only.
 - Heating capacities refer to instant capacity values.

Cooling Capacities - VLH STD/HSE - L Version

VLH STD/HSE models	LWT (°C)	Condenser entering air temperature (°C)											
		25		30		32		35		40		44	
		Cooling capacity (kW)	Input power (kW)	Cooling capacity (kW)	Input power (kW)	Cooling capacity (kW)	Input power (kW)	Cooling capacity (kW)	Input power (kW)	Cooling capacity (kW)	Input power (kW)	Cooling capacity (kW)	Input power (kW)
704 L	5	177.3	50.7	168.8	55.7	165.2	57.7	159.7	60.8	148.4	67.5	141.5	71.8
	6	182.6	51.3	173.7	56.3	170.1	58.3	164.4	61.5	152.9	68.2	145.7	72.6
	7	187.9	51.9	178.8	56.9	175.0	59.0	169.2	62.1	157.2	68.9	149.9	73.3
	8	192.6	52.5	183.3	57.5	179.5	59.6	173.4	62.8	161.3	69.6	153.7	74.0
	9	197.4	53.1	187.8	58.2	183.8	60.3	177.8	63.4	165.3	70.3	157.6	74.7
	10	202.1	53.8	192.4	58.9	188.3	61.0	182.1	64.2	169.1	71.0	161.2	75.4
804 L	12	211.8	55.1	201.5	60.3	197.3	62.4	190.7	65.6	177.2	72.5	168.9	77.0
	15	226.2	57.3	215.3	62.4	210.8	64.5	203.6	67.8	189.4	74.8	180.5	79.3
	5	200.8	56.2	191.1	61.7	187.1	63.9	180.8	67.3	168.1	74.8	160.2	79.5
	6	206.8	56.8	196.7	62.4	192.6	64.6	186.1	68.1	173.1	75.6	165.0	80.4
	7	212.8	57.5	202.4	63.1	198.1	65.4	191.6	68.8	178.1	76.3	169.8	81.2
	8	218.1	58.2	207.6	63.8	203.2	66.1	196.4	69.6	182.6	77.1	174.1	81.9
904 L	9	223.6	58.9	212.7	64.5	208.1	66.8	201.4	70.3	187.2	77.8	178.4	82.7
	10	228.9	59.6	217.8	65.2	213.2	67.6	206.2	71.1	191.5	78.6	182.6	83.6
	12	239.8	61.1	228.1	66.8	223.4	69.1	216.0	72.6	200.7	80.3	191.3	85.3
	15	256.1	63.4	243.9	69.1	238.7	71.5	230.6	75.1	214.5	82.8	204.4	87.9
	5	231.8	63.9	220.7	70.2	216.0	72.7	208.8	76.6	194.1	85.1	185.0	90.5
	6	238.7	64.6	227.1	71.0	222.4	73.5	214.9	77.5	199.9	86.0	190.5	91.5
1004 L	7	245.7	65.4	233.7	71.8	228.8	74.4	221.2	78.3	205.6	86.9	196.0	92.4
	8	251.8	66.2	239.7	72.6	234.6	75.2	226.7	79.2	210.8	87.7	201.0	93.2
	9	258.1	67.0	245.6	73.4	240.3	76.1	232.5	80.0	216.1	88.6	206.0	94.2
	10	264.3	67.9	251.5	74.2	246.1	76.9	238.0	80.9	221.0	89.5	210.8	95.1
	12	276.9	69.5	263.4	76.0	257.9	78.7	249.3	82.7	231.7	91.4	220.8	97.1
	15	295.7	72.2	281.5	78.6	275.6	81.4	266.2	85.5	247.6	94.3	236.0	100.0
1104 L	5	249.2	67.7	237.2	74.3	232.2	77.0	224.4	81.1	208.6	90.1	198.9	95.8
	6	256.6	68.4	244.1	75.1	239.0	77.9	231.0	82.1	214.9	91.0	204.8	96.9
	7	264.1	69.3	251.3	76.0	245.9	78.8	237.8	82.9	221.0	92.0	210.7	97.8
	8	270.7	70.1	257.6	76.8	252.2	79.6	243.8	83.8	226.6	92.9	216.1	98.7
	9	277.5	70.9	264.0	77.7	258.3	80.5	249.9	84.7	232.3	93.8	221.5	99.7
	10	284.1	71.9	270.4	78.6	264.6	81.5	255.9	85.7	237.6	94.7	226.6	100.7
1204 L	12	297.6	73.6	283.2	80.5	277.3	83.3	268.1	87.5	249.1	96.8	237.4	102.8
	15	317.9	76.4	302.7	83.3	296.3	86.2	286.2	90.6	266.2	99.8	253.7	105.9
	5	274.6	79.8	261.5	87.6	255.9	90.8	247.4	95.6	229.9	106.2		
	6	282.9	80.7	269.0	88.6	263.5	91.8	254.6	96.7	236.8	107.3		
	7	291.1	81.6	276.9	89.5	271.1	92.8	262.1	97.7	243.6	108.4		
	8	298.4	82.6	284.0	90.5	278.0	93.8	268.7	98.8	249.8	109.4		
1104 L	9	305.8	83.6	291.0	91.6	284.7	94.9	275.5	99.8	256.1	110.5		
	10	313.1	84.7	298.0	92.6	291.6	96.0	282.1	101.0	261.9	111.7		
	12	328.1	86.8	312.1	94.9	305.6	98.2	295.4	103.1	274.6	114.1		
	15	350.4	90.1	333.6	98.1	326.5	101.5	315.5	106.7	293.4	117.6		
	5	299.9	92.9	285.5	102.0	279.4	105.7	270.1	111.4	251.1	123.7		
	6	308.9	93.9	293.8	103.1	287.7	106.9	278.0	112.6	258.6	125.0		
1204 L	7	317.8	95.1	302.4	104.3	296.0	108.1	286.2	113.8	266.0	126.3		
	8	325.8	96.2	310.1	105.4	303.6	109.3	293.4	115.1	272.8	127.5		
	9	333.9	97.4	317.7	106.7	310.9	110.6	300.8	116.2	279.6	128.8		
	10	341.9	98.6	325.4	107.9	318.5	111.8	308.0	117.6	286.0	130.1		
	12	358.2	101.0	340.8	110.5	333.7	114.4	322.6	120.1	299.8	132.9		
	15	382.6	104.9	364.2	114.3	356.5	118.3	344.5	124.3	320.4	137.0		

Notes : - LWT : Leaving water temperature.
 - Power input data are given for compressors only.

Heating Capacities - VLH STD/HSE - L Version

VLH STD/HSE models	LWT (°C)	Ambient coil entering air temperature (°C)													
		-5		-3		0		5		7		10		15	
		Heating capacity (kW)	Input power (kW)	Heating capacity (kW)	Input power (kW)	Heating capacity (kW)	Input power (kW)	Heating capacity (kW)	Input power (kW)	Heating capacity (kW)	Input power (kW)	Heating capacity (kW)	Input power (kW)	Heating capacity (kW)	Input power (kW)
704 L	30	148.6	42.1	156.3	42.2	169.0	42.4	191.1	43.0	200.8	43.3	216.3	43.7	245.1	44.4
	35	146.6	49.5	155.7	47.3	168.0	47.4	189.2	48.0	198.5	48.3	213.4	48.7	240.8	49.5
	40	144.9	55.5	154.2	53.0	167.2	53.1	187.4	53.8	196.3	54.0	210.5	54.5	236.5	55.3
	45	143.3	62.4	152.4	59.5	165.3	59.8	185.8	60.3	194.2	60.6	207.8	61.0	232.3	61.9
	50					163.5	67.6	184.9	67.9	192.6	68.2	205.3	68.5	228.2	69.3
804 L	30	164.9	44.0	173.6	44.1	187.6	44.2	212.2	44.9	222.9	45.2	240.2	45.6	272.1	46.4
	35	162.8	51.7	172.9	49.4	186.5	49.5	210.0	50.1	220.3	50.5	236.9	50.9	267.3	51.7
	40	160.8	58.0	171.2	55.3	185.6	55.5	208.1	56.1	218.0	56.4	233.7	56.9	262.6	57.7
	45	159.1	65.2	169.2	62.2	183.5	62.4	206.3	63.0	215.6	63.3	230.7	63.7	257.9	64.6
	50					181.5	70.6	205.3	71.0	213.9	71.2	227.9	71.6	253.3	72.4
904 L	30	188.6	49.5	198.4	49.6	214.5	49.8	242.6	50.5	254.9	50.8	274.6	51.3	311.1	52.2
	35	186.1	58.2	197.7	55.5	213.2	55.7	240.1	56.4	251.9	56.7	270.9	57.2	305.7	58.2
	40	183.9	65.2	195.7	62.2	212.2	62.4	237.9	63.2	249.2	63.4	267.2	64.0	300.2	64.9
	45	181.9	73.3	193.5	69.9	209.8	70.2	235.9	70.8	246.5	71.2	263.8	71.7	294.8	72.7
	50					207.6	79.4	234.7	79.8	244.5	80.1	260.6	80.5	289.6	81.5
1004 L	30	199.7	55.0	210.2	55.1	227.2	55.3	256.9	56.1	270.0	56.5	290.9	57.0	329.5	58.0
	35	197.1	64.6	209.4	61.7	225.9	61.9	254.3	62.6	266.8	63.0	286.9	63.6	323.8	64.6
	40	194.8	72.5	207.3	69.1	224.8	69.4	252.0	70.2	264.0	70.5	283.0	71.1	318.0	72.1
	45	192.7	81.5	205.0	77.7	222.2	78.0	249.9	78.7	261.1	79.1	279.4	79.7	312.3	80.8
	50					219.8	88.2	248.6	88.7	259.0	89.0	276.0	89.5	306.8	90.5
1104 L	30	220.0	63.4	231.5	63.6	250.2	63.7	283.0	64.7	297.4	65.1	320.4	65.8	363.0	66.8
	35	217.1	74.5	230.7	71.1	248.8	71.3	280.1	72.2	293.9	72.7	316.1	73.3	356.6	74.5
	40	214.5	83.5	228.4	79.7	247.6	80.0	277.5	80.9	290.8	81.3	311.8	82.0	350.3	83.2
	45	212.2	93.9	225.8	89.6	244.7	89.9	275.2	90.7	287.6	91.2	307.7	91.8	344.0	93.1
	50					242.2	101.7	273.8	102.2	285.3	102.6	304.0	103.1	337.9	104.3
1204 L	30	245.3	71.8	258.2	72.0	279.0	72.2	315.6	73.2	331.6	73.8	357.3	74.5	404.7	75.7
	35	242.1	84.4	257.2	80.6	277.4	80.8	312.4	81.8	327.8	82.3	352.4	83.1	397.7	84.4
	40	239.2	94.6	254.6	90.3	276.1	90.6	309.5	91.6	324.2	92.0	347.6	92.9	390.6	94.2
	45	236.7	106.4	251.7	101.4	272.9	101.9	306.9	102.8	320.7	103.3	343.1	104.0	383.6	105.5
	50					270.0	115.2	305.3	115.8	318.1	116.2	339.0	116.8	376.8	118.2

- Notes :**
- LWT : Leaving water temperature.
 - Power input data are given for compressors only.
 - Heating capacities refer to instant capacity values.

Cooling Capacities - VLH STD/HSE - S Version

VLH STD/HSE models	LWT (°C)	Condenser entering air temperature (°C)									
		25		30		32		35		40	
		Cooling capacity (kW)	Input power (kW)	Cooling capacity (kW)	Input power (kW)	Cooling capacity (kW)	Input power (kW)	Cooling capacity (kW)	Input power (kW)	Cooling capacity (kW)	Input power (kW)
704 S	5	172.5	53.0	164.2	58.2	160.7	60.3	155.3	63.5	144.4	70.5
	6	177.6	53.6	169.0	58.8	165.5	60.9	159.9	64.2	148.7	71.3
	7	182.8	54.2	173.9	59.5	170.2	61.7	164.6	64.9	153.0	72.0
	8	187.4	54.9	178.3	60.1	174.6	62.3	168.7	65.6	156.9	72.7
	9	192.1	55.5	182.7	60.9	178.8	63.0	173.0	66.3	160.8	73.4
	10	196.6	56.3	187.1	61.5	183.2	63.8	177.1	67.1	164.5	74.2
	12	206.0	57.6	196.0	63.0	191.9	65.2	185.5	68.5	172.4	75.8
15	220.0	59.9	209.5	65.2	205.1	67.4	198.1	70.9	184.3	78.1	
804 S	5	194.6	59.0	185.2	64.8	181.3	67.2	175.3	70.8	162.9	78.6
	6	200.4	59.7	190.6	65.5	186.7	67.9	180.4	71.6	167.8	79.4
	7	206.2	60.4	196.2	66.3	192.0	68.7	185.7	72.3	172.6	80.2
	8	211.4	61.1	201.2	67.0	197.0	69.4	190.3	73.1	177.0	81.0
	9	216.7	61.9	206.1	67.8	201.7	70.2	195.2	73.8	181.4	81.8
	10	221.8	62.7	211.1	68.5	206.6	71.0	199.8	74.7	185.6	82.6
	12	232.4	64.2	221.1	70.2	216.5	72.7	209.3	76.3	194.5	84.4
15	248.2	66.7	236.3	72.6	231.3	75.1	223.5	79.0	207.9	87.1	
904 S	5	225.1	66.6	214.3	73.1	209.7	75.8	202.7	79.9	188.4	88.7
	6	231.8	67.4	220.5	74.0	215.9	76.6	208.7	80.8	194.1	89.6
	7	238.5	68.2	227.0	74.8	222.1	77.5	214.8	81.6	199.6	90.5
	8	244.5	69.0	232.7	75.6	227.8	78.4	220.2	82.5	204.7	91.4
	9	250.6	69.8	238.4	76.5	233.3	79.3	225.8	83.3	209.9	92.3
	10	256.6	70.7	244.2	77.3	239.0	80.2	231.2	84.3	214.6	93.3
	12	268.9	72.5	255.8	79.2	250.4	82.0	242.1	86.2	225.0	95.3
15	287.1	75.3	273.4	82.0	267.6	84.8	258.5	89.1	240.5	98.3	
1004 S	5	242.3	70.5	230.6	77.4	225.7	80.2	218.2	84.5	202.8	93.8
	6	249.5	71.2	237.3	78.2	232.4	81.0	224.6	85.4	208.9	94.8
	7	256.8	72.1	244.3	79.1	239.1	82.0	231.2	86.3	214.9	95.8
	8	263.2	73.0	250.5	80.0	245.2	82.9	237.0	87.3	220.4	96.7
	9	269.8	73.9	256.7	80.9	251.1	83.8	243.0	88.1	225.9	97.6
	10	276.2	74.8	262.9	81.8	257.3	84.8	248.8	89.2	231.0	98.6
	12	289.4	76.6	275.3	83.8	269.6	86.7	260.6	91.1	242.2	100.8
15	309.1	79.6	294.3	86.7	288.0	89.7	278.3	94.3	258.8	103.9	
1104 S	5	266.3	83.4	253.5	91.6	248.1	94.9	239.8	100.0		
	6	274.2	84.4	260.8	92.6	255.4	96.0	246.8	101.2		
	7	282.2	85.4	268.5	93.7	262.8	97.1	254.1	102.2		
	8	289.3	86.4	275.3	94.7	269.5	98.1	260.5	103.3		
	9	296.5	87.5	282.1	95.8	276.0	99.3	267.1	104.4		
	10	303.6	88.6	288.9	96.9	282.7	100.4	273.4	105.6		
	12	318.0	90.7	302.6	99.2	296.3	102.7	286.4	107.9		
15	339.7	94.2	323.4	102.7	316.6	106.2	305.8	111.6			
1204 S	5	289.9	97.5	276.0	107.0	270.1	110.9	261.1	116.9		
	6	298.6	98.6	284.0	108.2	278.1	112.1	268.8	118.2		
	7	307.3	99.8	292.4	109.4	286.2	113.5	276.7	119.4		
	8	315.0	101.0	299.8	110.6	293.5	114.7	283.6	120.7		
	9	322.9	102.2	307.2	112.0	300.5	116.0	290.8	121.9		
	10	330.6	103.5	314.6	113.2	307.9	117.3	297.8	123.4		
	12	346.3	106.0	329.5	115.9	322.6	120.0	311.9	126.1		
15	369.9	110.1	352.2	119.9	344.7	124.1	333.0	130.4			

Notes : - LWT : Leaving water temperature.
 - Power input data are given for compressors only.

Heating Capacities - VLH STD/HSE - S Version

VLH STD/HSE models	LWT (°C)	Ambient coil entering air temperature (°C)													
		-5		-3		0		5		7		10		15	
		Heating capacity (kW)	Input power (kW)	Heating capacity (kW)	Input power (kW)	Heating capacity (kW)	Input power (kW)	Heating capacity (kW)	Input power (kW)	Heating capacity (kW)	Input power (kW)	Heating capacity (kW)	Input power (kW)	Heating capacity (kW)	Input power (kW)
704 S	30	140.5	42.2	147.9	42.3	159.8	42.4	180.8	43.0	189.9	43.3	204.6	43.8	231.8	44.5
	35	138.7	49.6	147.3	47.3	158.9	47.5	178.9	48.1	187.7	48.4	201.9	48.8	227.8	49.6
	40	137.0	55.6	145.9	53.1	158.2	53.2	177.3	53.8	185.7	54.1	199.1	54.6	223.7	55.4
	45	135.6	62.5	144.2	59.6	156.3	59.9	175.8	60.4	183.7	60.7	196.6	61.1	219.7	62.0
	50					154.7	67.7	174.9	68.0	182.2	68.3	194.2	68.7	215.8	69.4
804 S	30	154.8	43.9	162.9	44.0	176.1	44.1	199.2	44.7	209.3	45.1	225.5	45.5	255.4	46.3
	35	152.8	51.6	162.3	49.2	175.1	49.3	197.1	50.0	206.9	50.3	222.4	50.7	251.0	51.6
	40	151.0	57.8	160.7	55.1	174.3	55.3	195.3	56.0	204.6	56.2	219.4	56.7	246.5	57.5
	45	149.4	65.0	158.9	62.0	172.2	62.2	193.7	62.8	202.4	63.1	216.6	63.5	242.1	64.4
	50					170.4	70.4	192.7	70.7	200.8	71.0	213.9	71.4	237.8	72.2
904 S	30	177.8	49.4	187.1	49.6	202.2	49.7	228.7	50.4	240.3	50.8	258.9	51.3	293.3	52.1
	35	175.5	58.1	186.4	55.5	201.0	55.6	226.4	56.3	237.5	56.7	255.4	57.2	288.2	58.1
	40	173.4	65.1	184.5	62.1	200.1	62.4	224.3	63.1	235.0	63.4	251.9	63.9	283.1	64.8
	45	171.5	73.2	182.4	69.8	197.8	70.1	222.4	70.7	232.4	71.1	248.7	71.6	278.0	72.6
	50					195.7	79.3	221.2	79.7	230.5	80.0	245.6	80.4	273.1	81.3
1004 S	30	187.0	54.8	196.8	54.9	212.7	55.1	240.6	55.9	252.8	56.3	272.4	56.8	308.6	57.8
	35	184.6	64.4	196.1	61.5	211.5	61.6	238.1	62.4	249.9	62.8	268.7	63.4	303.2	64.4
	40	182.4	72.2	194.1	68.9	210.5	69.1	235.9	69.9	247.2	70.2	265.0	70.8	297.8	71.9
	45	180.4	81.2	191.9	77.4	208.1	77.7	234.0	78.4	244.5	78.8	261.6	79.4	292.4	80.5
	50					205.9	87.9	232.8	88.3	242.5	88.7	258.4	89.1	287.3	90.1
1104 S	30	203.7	62.6	214.4	62.8	231.7	63.0	262.0	63.9	275.4	64.3	296.7	65.0	336.1	66.0
	35	201.1	73.6	213.6	70.3	230.3	70.5	259.4	71.4	272.2	71.8	292.7	72.4	330.2	73.6
	40	198.7	82.5	211.4	78.7	229.3	79.0	257.0	79.9	269.2	80.3	288.7	81.0	324.4	82.2
	45	196.5	92.8	209.0	88.5	226.6	88.8	254.8	89.6	266.3	90.1	284.9	90.7	318.5	92.0
	50					224.2	100.5	253.5	101.0	264.2	101.4	281.5	101.9	312.9	103.1
1204 S	30	226.4	71.7	238.3	71.9	257.5	72.1	291.3	73.1	306.1	73.6	329.7	74.3	373.6	75.6
	35	223.5	84.2	237.4	80.4	256.0	80.6	288.3	81.7	302.5	82.2	325.3	82.9	367.0	84.2
	40	220.8	94.4	235.0	90.1	254.9	90.4	285.6	91.4	299.3	91.9	320.9	92.7	360.5	94.0
	45	218.4	106.2	232.4	101.2	251.9	101.7	283.3	102.6	296.0	103.1	316.7	103.8	354.0	105.3
	50					249.2	115.0	281.8	115.6	293.6	116.0	312.9	116.6	347.8	117.9

- Notes :**
- LWT : Leaving water temperature.
 - Power input data are given for compressors only.
 - Heating capacities refer to instant capacity values.

Cooling Capacities - VLH HT

VLH HT models	LWT (°C)	Condenser entering air temperature (°C)													
		25		30		32		35		40		44		46	
		Cooling capacity (kW)	Input power (kW)	Cooling capacity (kW)	Input power (kW)	Cooling capacity (kW)	Input power (kW)	Cooling capacity (kW)	Input power (kW)	Cooling capacity (kW)	Input power (kW)	Cooling capacity (kW)	Input power (kW)	Cooling capacity (kW)	Input power (kW)
704	5	184.0	47.7	175.2	52.3	171.4	54.3	165.7	57.2	154.1	63.5	146.9	67.5	139.7	71.6
	6	189.5	48.2	180.2	52.9	176.5	54.8	170.6	57.8	158.7	64.1	151.2	68.2	143.8	72.3
	7	195.0	48.8	185.5	53.5	181.6	55.5	175.6	58.4	163.2	64.8	155.6	68.9	148.0	73.0
	8	199.9	49.4	190.3	54.1	186.3	56.1	180.0	59.1	167.4	65.4	159.5	69.6	151.7	73.7
	9	204.9	50.0	194.9	54.8	190.7	56.7	184.6	59.6	171.6	66.1	163.5	70.2	155.5	74.4
	10	209.8	50.6	199.6	55.4	195.4	57.4	189.0	60.4	175.5	66.7	167.3	70.9	159.2	75.1
804	5	209.3	52.6	199.2	57.7	195.0	59.8	188.5	63.0	175.2	70.0	167.0	74.5	158.8	78.9
	6	215.5	53.2	205.0	58.4	200.7	60.5	194.0	63.7	180.4	70.7	172.0	75.2	163.5	79.8
	7	221.8	53.8	211.0	59.0	206.5	61.2	199.7	64.4	185.6	71.5	176.9	76.0	168.3	80.5
	8	227.3	54.5	216.4	59.7	211.8	61.8	204.7	65.1	190.3	72.1	181.4	76.7	172.6	81.3
	9	233.0	55.1	221.7	60.4	216.9	62.6	209.9	65.8	195.1	72.9	186.0	77.4	176.9	82.0
	10	238.6	55.8	227.0	61.0	222.2	63.3	214.9	66.6	199.6	73.6	190.3	78.2	181.1	82.8
904	5	240.5	59.8	228.9	65.6	224.1	68.0	216.6	71.6	201.3	79.6	191.9	84.6	182.5	89.7
	6	247.7	60.4	235.6	66.3	230.7	68.7	222.9	72.5	207.4	80.4	197.6	85.5	187.9	90.6
	7	254.9	61.2	242.5	67.1	237.3	69.6	229.5	73.2	213.3	81.2	203.3	86.4	193.4	91.5
	8	261.3	61.9	248.7	67.8	243.4	70.3	235.2	74.0	218.7	82.0	208.5	87.2	198.3	92.4
	9	267.8	62.6	254.8	68.6	249.3	71.1	241.2	74.8	224.2	82.8	213.7	88.0	203.3	93.2
	10	274.2	63.5	260.9	69.4	255.4	71.9	247.0	75.6	229.3	83.7	218.7	88.9	208.1	94.2
1004	5	262.1	62.7	249.5	68.8	244.2	71.3	236.0	75.2	219.4	83.5	209.2	88.8	198.9	94.1
	6	269.9	63.4	256.7	69.6	251.4	72.1	243.0	76.0	226.0	84.3	215.4	89.7	204.8	95.1
	7	277.8	64.2	264.3	70.4	258.6	73.0	250.1	76.8	232.4	85.2	221.6	90.6	210.8	96.0
	8	284.7	64.9	271.0	71.2	265.3	73.8	256.4	77.7	238.4	86.0	227.2	91.5	216.1	96.9
	9	291.8	65.7	277.6	72.0	271.7	74.6	262.9	78.4	244.4	86.9	232.9	92.4	221.5	97.8
	10	298.8	66.6	284.3	72.8	278.3	75.5	269.1	79.4	249.9	87.8	238.3	93.3	226.7	98.8
1104	5	313.0	68.2	297.8	74.6	291.6	77.2	281.9	81.1	262.0	89.7	249.7	95.3	237.4	100.8
	6	320.2	68.9	304.8	75.4	298.4	78.0	288.4	82.0	268.1	90.6	255.6	96.2	243.1	101.7
	7	327.8	69.6	311.9	76.2	305.5	78.8	295.5	82.8	274.2	91.5	261.9	97.1	248.8	102.6
	8	334.8	70.4	319.0	77.0	312.6	79.6	283.4	83.6	280.3	92.4	268.0	98.0	254.9	103.5
	9	342.1	71.2	326.1	77.8	319.7	80.4	290.6	84.4	286.4	93.3	274.1	98.9	261.0	104.4
	10	349.6	72.0	333.2	78.6	326.8	81.2	297.5	85.2	292.5	94.2	280.2	99.8	267.1	105.3
1204	5	369.6	82.9	351.9	90.3	344.5	93.4	332.8	98.2	309.5	108.3	295.0	114.9	280.4	121.5
	6	320.2	83.9	304.8	92.1	298.4	95.5	288.4	100.6	268.1	111.7	255.6	118.9	243.1	126.0
	7	329.8	84.9	313.7	93.2	307.2	96.5	296.9	101.8	276.1	112.9	263.2	120.1	250.2	127.3
	8	339.4	85.9	322.9	94.2	316.0	97.7	305.6	102.8	284.0	114.1	270.8	121.3	257.5	128.5
	9	347.9	86.9	331.1	95.3	324.1	98.7	313.2	103.9	291.3	115.1	277.7	122.4	264.1	129.7
	10	356.6	88.0	339.2	96.4	331.9	99.9	321.2	105.0	298.6	116.3	284.6	123.6	270.7	130.9
1204	10	365.1	89.1	347.4	97.4	340.0	101.0	328.9	106.2	305.4	117.5	291.2	124.9	277.1	132.2
	12	382.5	91.3	363.9	99.8	356.3	103.3	344.5	108.5	320.1	120.0	305.1	127.5	290.1	135.0
	15	408.5	94.8	388.9	103.3	380.7	106.8	367.8	112.3	342.1	123.8	326.0	131.4	309.9	138.9

Notes : - LWT : Leaving water temperature.
- Power input data are given for compressors only.

Heating Capacities - VLH HT

VLH HT models	LWT (°C)	Ambient coil entering air temperature (°C)													
		-5		-3		0		5		7		10		15	
		Heating capacity (kW)	Input power (kW)	Heating capacity (kW)	Input power (kW)	Heating capacity (kW)	Input power (kW)	Heating capacity (kW)	Input power (kW)	Heating capacity (kW)	Input power (kW)	Heating capacity (kW)	Input power (kW)	Heating capacity (kW)	Input power (kW)
704	30	153.5	42.1	161.6	42.2	174.6	42.4	197.5	43.0	207.5	43.3	223.6	43.7	253.3	44.4
	35	151.5	49.5	161.0	47.3	173.6	47.4	195.5	48.0	205.1	48.3	220.6	48.7	248.9	49.5
	40	149.7	55.5	159.4	53.0	172.8	53.1	193.7	53.8	202.9	54.0	217.6	54.5	244.5	55.3
	45	148.1	62.4	157.5	59.5	170.8	59.8	192.1	60.3	200.7	60.6	214.7	61.0	240.0	61.9
	50	146.5	71.4	155.9	67.6	169.0	67.6	191.1	67.9	199.1	68.2	212.1	68.5	235.8	69.3
804	30	171.4	44.1	180.3	44.3	194.9	44.4	220.4	45.0	231.6	45.3	249.5	45.8	282.7	46.5
	35	169.1	51.9	179.6	49.5	193.8	49.7	218.2	50.3	228.9	50.6	246.2	51.1	277.8	51.9
	40	167.1	58.2	177.9	55.5	192.9	55.7	216.2	56.3	226.5	56.6	242.8	57.1	272.8	57.9
	45	165.3	65.4	175.8	62.4	190.6	62.6	214.4	63.2	224.0	63.5	239.7	63.9	267.9	64.8
	50	163.5	74.9	174.0	70.8	188.6	70.8	213.2	71.2	222.2	71.4	236.8	71.8	263.2	72.6
904	30	196.3	49.6	206.6	49.8	223.2	49.9	252.5	50.6	265.3	51.0	285.9	51.5	323.8	52.3
	35	193.7	58.3	205.8	55.7	222.0	55.8	249.9	56.5	262.2	56.9	282.0	57.4	318.2	58.3
	40	191.4	65.4	203.7	62.4	220.9	62.6	247.6	63.3	259.4	63.6	278.2	64.2	312.5	65.1
	45	189.4	73.5	201.4	70.1	218.4	70.4	245.6	71.0	256.6	71.4	274.6	71.9	306.9	72.9
	50	187.3	84.2	199.4	79.6	216.1	79.6	244.3	80.0	254.5	80.3	271.2	80.8	301.5	81.7
1004	30	209.4	55.1	220.3	55.3	238.1	55.4	269.3	56.2	283.0	56.6	304.9	57.2	345.4	58.1
	35	206.6	64.8	219.5	61.9	236.8	62.0	266.6	62.8	279.7	63.2	300.8	63.8	339.4	64.8
	40	204.2	72.6	217.3	69.3	235.7	69.5	264.1	70.3	276.7	70.7	296.7	71.3	333.4	72.3
	45	202.0	81.7	214.9	77.9	232.9	78.2	261.9	78.9	273.7	79.3	292.9	79.9	327.3	81.0
	50	199.8	93.5	212.7	88.4	230.5	88.4	260.6	88.9	271.5	89.2	289.3	89.7	321.6	90.7
1104	30	233.7	63.5	245.9	63.7	265.8	63.9	300.6	64.8	315.9	65.3	340.3	65.9	385.5	67.0
	35	230.7	74.7	245.0	71.3	264.3	71.5	297.6	72.4	312.2	72.8	335.7	73.5	378.8	74.7
	40	227.9	83.7	242.6	79.9	263.0	80.2	294.8	81.1	308.9	81.4	331.2	82.2	372.1	83.4
	45	225.5	94.1	239.8	89.8	260.0	90.1	292.4	90.9	305.5	91.4	326.9	92.0	365.4	93.3
	50	223.0	107.8	237.4	101.9	257.2	101.9	290.8	102.5	303.1	102.8	322.9	103.4	359.0	104.6
1204	30	261.2	71.9	274.9	72.1	297.1	72.3	336.0	73.4	353.1	73.9	380.4	74.6	431.0	75.9
	35	257.8	84.6	273.9	80.7	295.4	80.9	332.6	82.0	349.0	82.5	375.3	83.2	423.5	84.6
	40	254.8	94.8	271.2	90.5	294.0	90.8	329.5	91.8	345.3	92.2	370.2	93.0	415.9	94.4
	45	252.0	106.6	268.1	101.6	290.6	102.1	326.8	103.0	341.5	103.5	365.4	104.2	408.4	105.7
	50	249.3	122.0	265.3	115.4	287.5	115.4	325.1	116.0	338.8	116.4	361.0	117.1	401.3	118.4

- Notes :**
- LWT : Leaving water temperature.
 - Power input data are given for compressors only.
 - Heating capacities refer to instant capacity values.

Evaporator Water Pressure Drop Curves

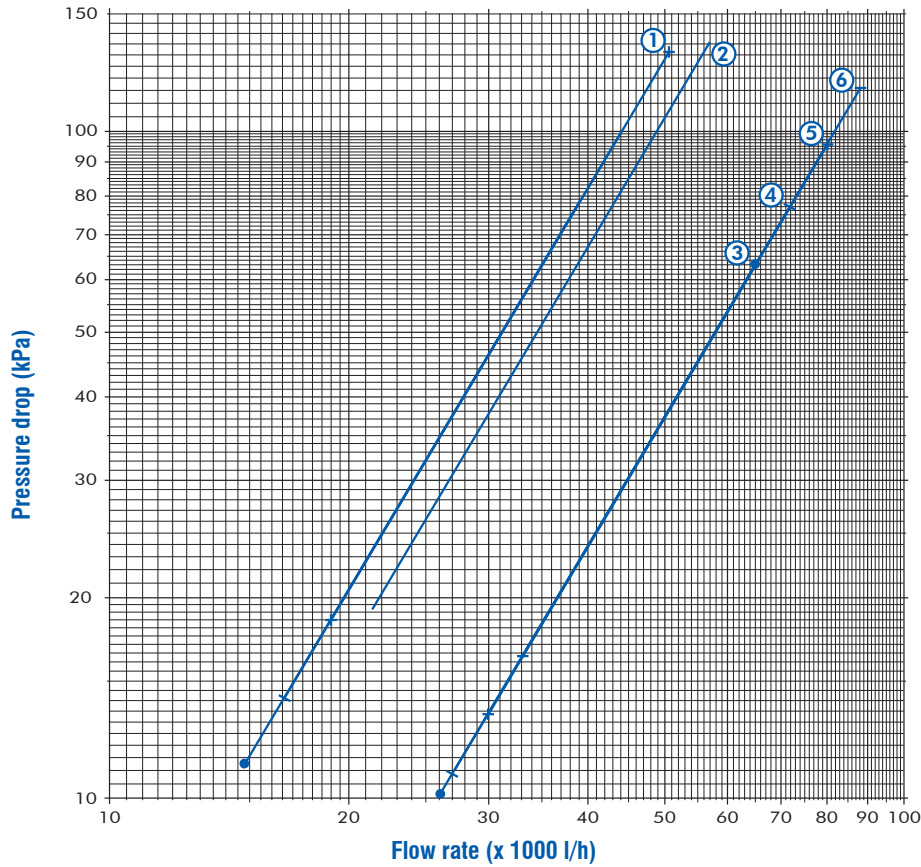

- ① Size 704
- ② Size 804
- ③ Size 904
- ④ Size 1004
- ⑤ Size 1104
- ⑥ Size 1204

Desuperheater Water Pressure Drop Curves

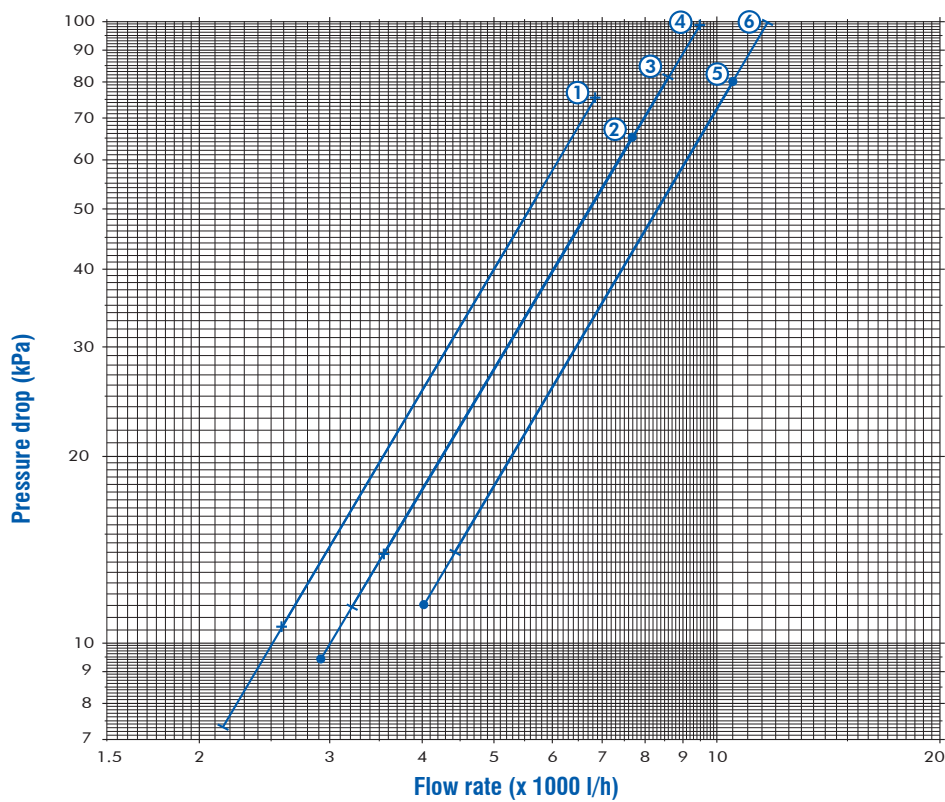

- ① Size 704
- ② Size 804
- ③ Size 904
- ④ Size 1004
- ⑤ Size 1104
- ⑥ Size 1204

Note : Flow rate refers to one condenser only.

Total Heat Recovery Condenser Water Pressure Drop Curves

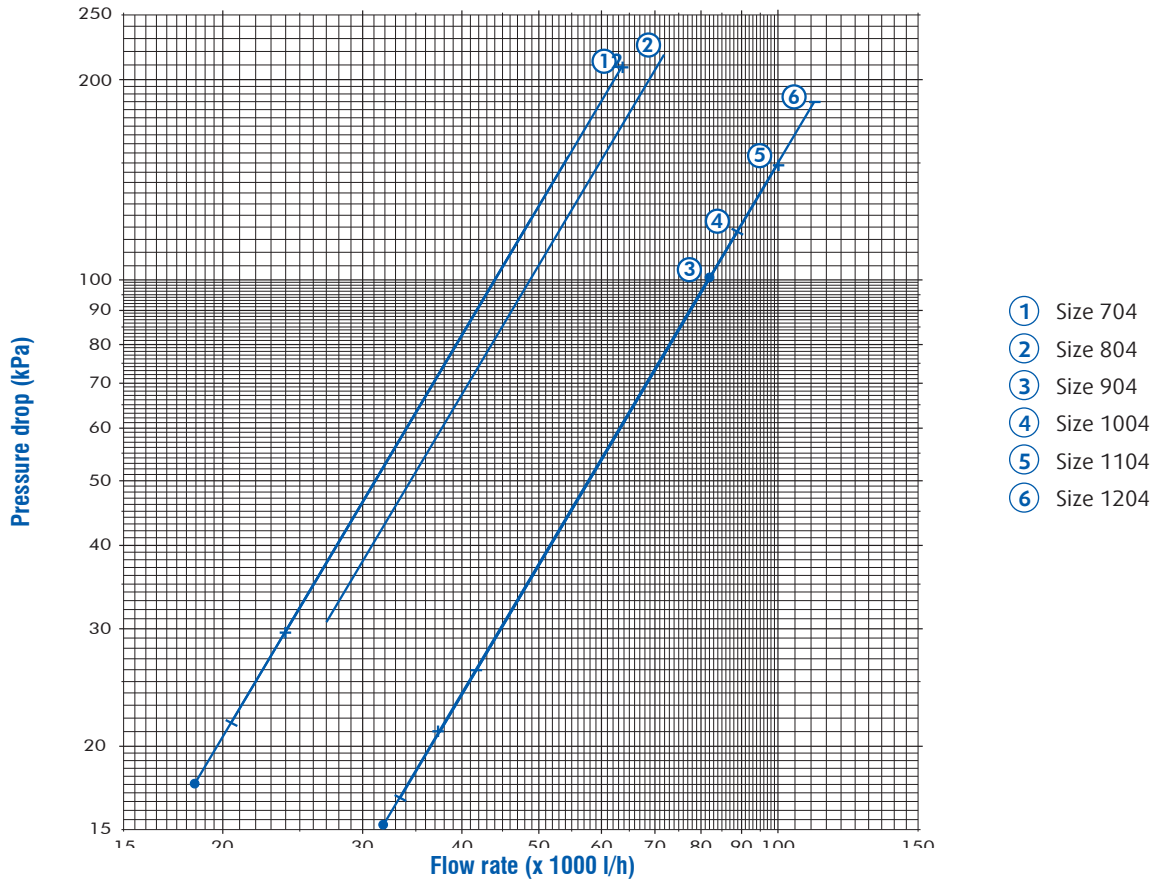

Water Pump Curves

Model VLH 704

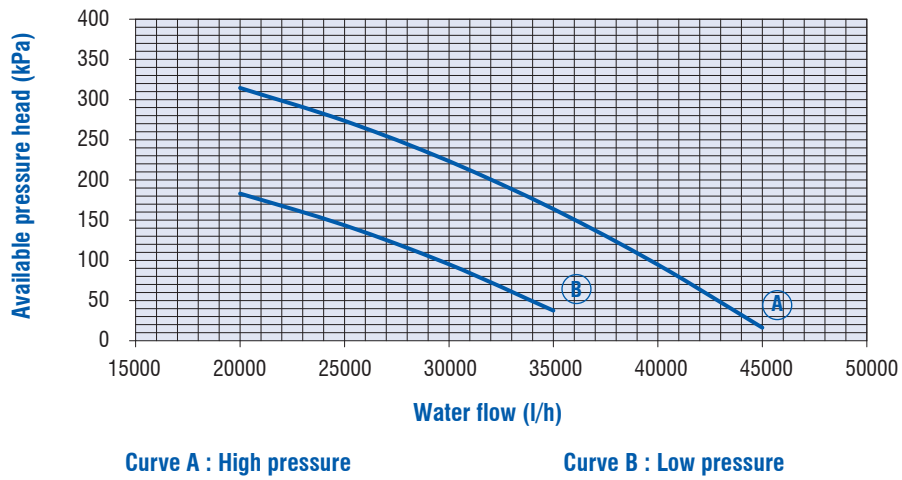

Model VLH 804

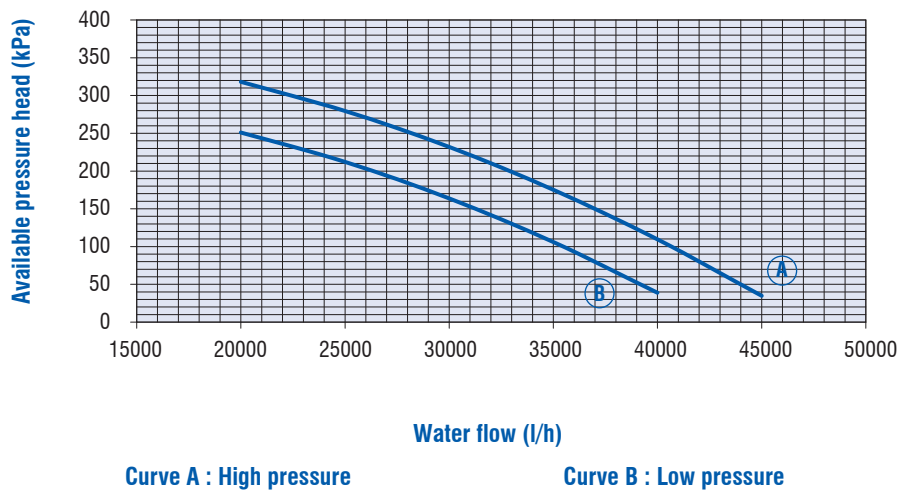

Water Pump Curves (continued)

Model VLH 904-1004

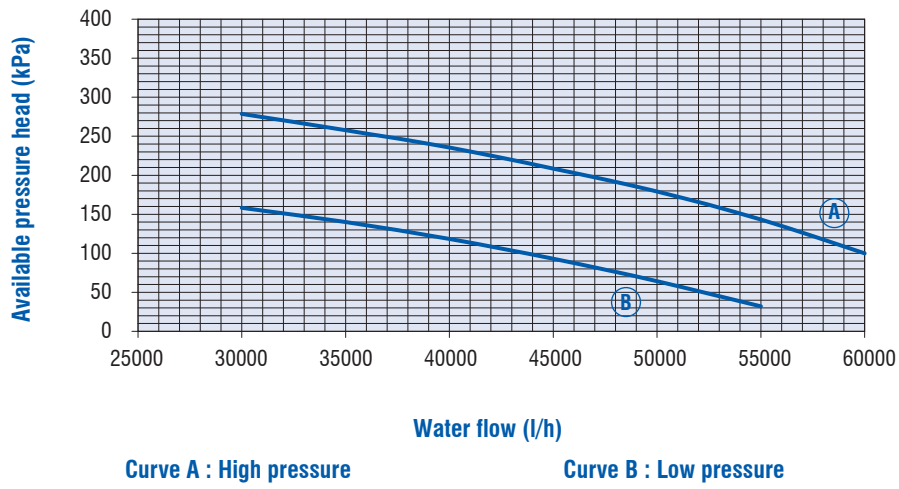

Model VLH 1104-1204

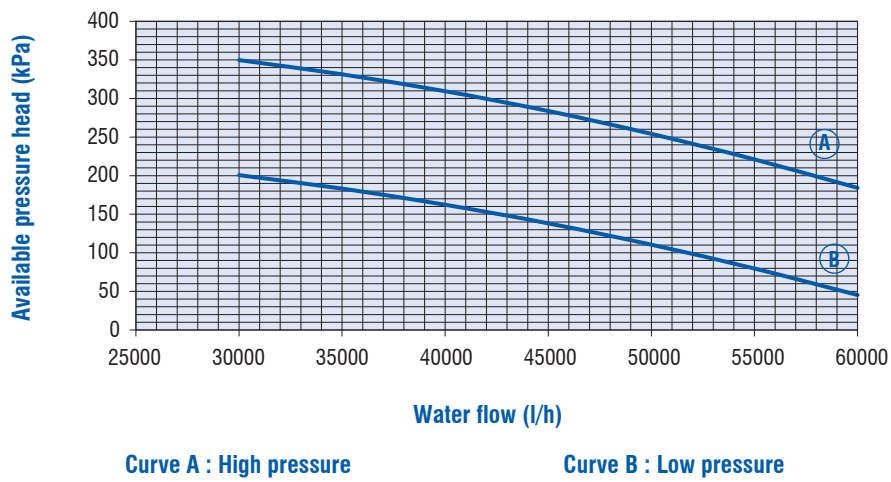

Hydronic Specification

Pump technical data

Low pressure						High pressure					
VLH	Q nom [m³/h]	Pump model	APH [kPa]	Power input [kW]	FLA [A]	VLH	Q nom [m³/h]	Pump model	APH [kPa]	Power input [kW]	FLA [A]
704	30.7	FHE 40-125/22	88	2.2	5.03	704	30.7	FHE 40-160/40	215	4	7.71
804	34.6	FHE 40-160/30	111	3	6.25	804	34.6	FHE 40-160/40	180	4	7.71
904	39.9	FHE 50-125/30	120	3	6.25	904	39.9	FHE 50-160/55	235	5.5	10.4
1004	43.7	FHE 50-125/30	100	3	6.25	1004	43.7	FHE 50-160/55	215	5.5	10.4
1104	48.7	FHE 50-125/40	119	4	7.71	1104	48.7	FHE 50-160/75	263	7.5	13.9
1204	53.9	FHE 50-125/40	87	4	7.71	1204	53.9	FHE 50-160/75	229	7.5	13.9

APH : Available Pressure Head.

Weight of external on-board hydrokit with buffer tank

Item	Weight (kg)
Single pump with buffer tank (500 litres)	350
Double pump with buffer tank (500 litres)	400
Buffer tank (500 litres) alone without pumps	300

Dimensions - VLH 704 to 1204

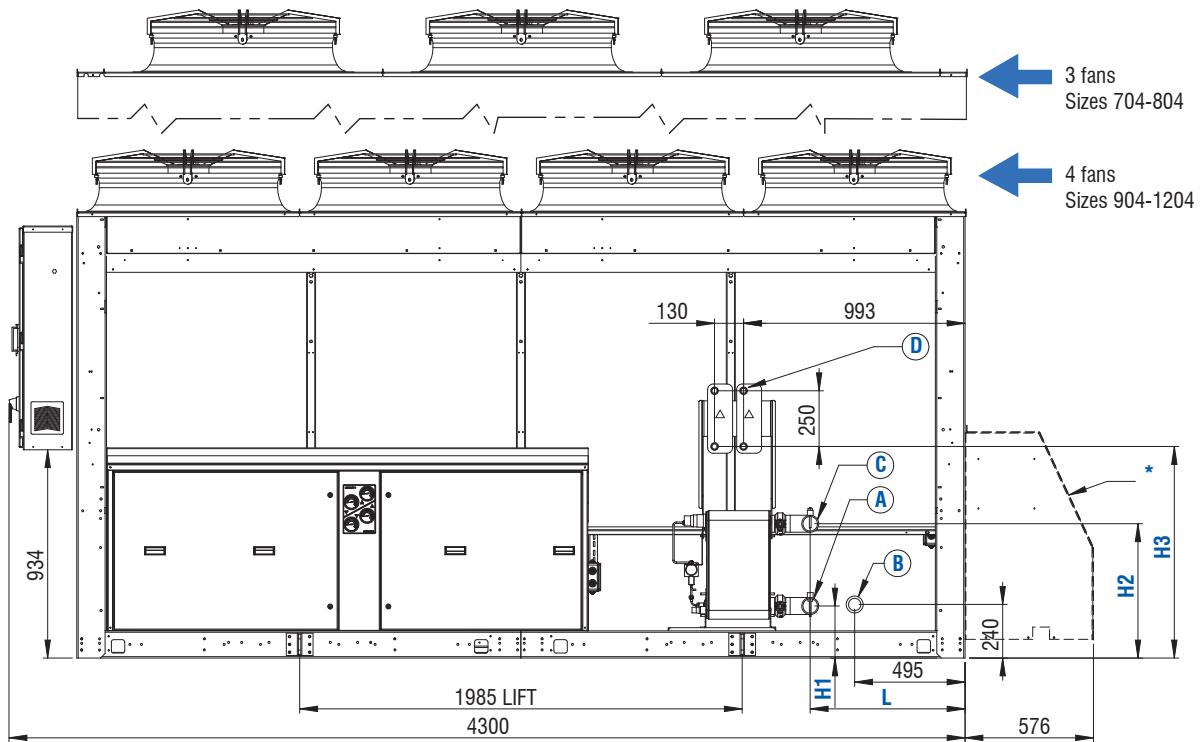

(*) ---- with 2 pumps only.

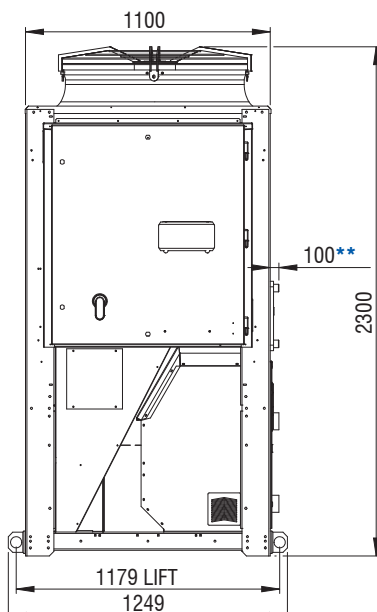
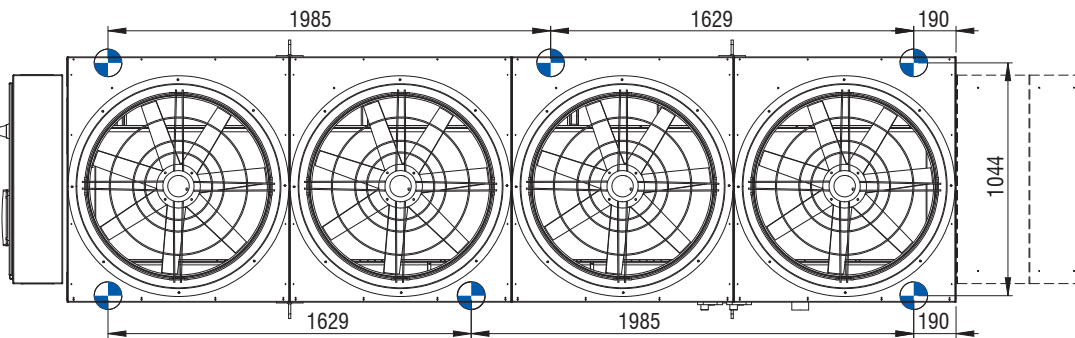

(**) Maximum with desuperheaters

Dimensions (mm)	704 - 804	904 - 1204
H1	233	273
H2	602	840
H3	950	977
L	695	718

Water connections	704 - 804	904 - 1204
Water outlet "A"	2" 1/2 Male	3" Male
Water inlet "B" (with pump)	2" 1/2 Male	3" Male
Water inlet "C" (no pump)	2" 1/2 Male	3" Male
Desuperheater in/out "D"	4 x 1" Male	4 x 1" Male

Dimensions - VLH 704 to 1204 with optional on board hydro kit

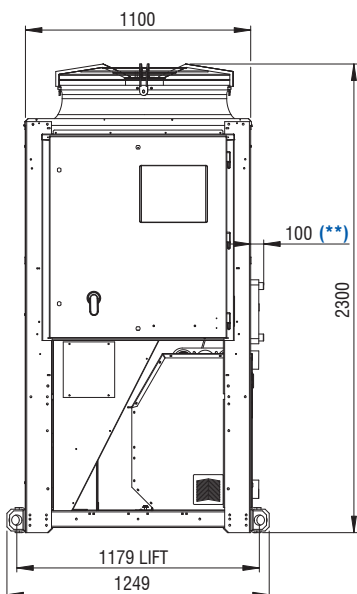
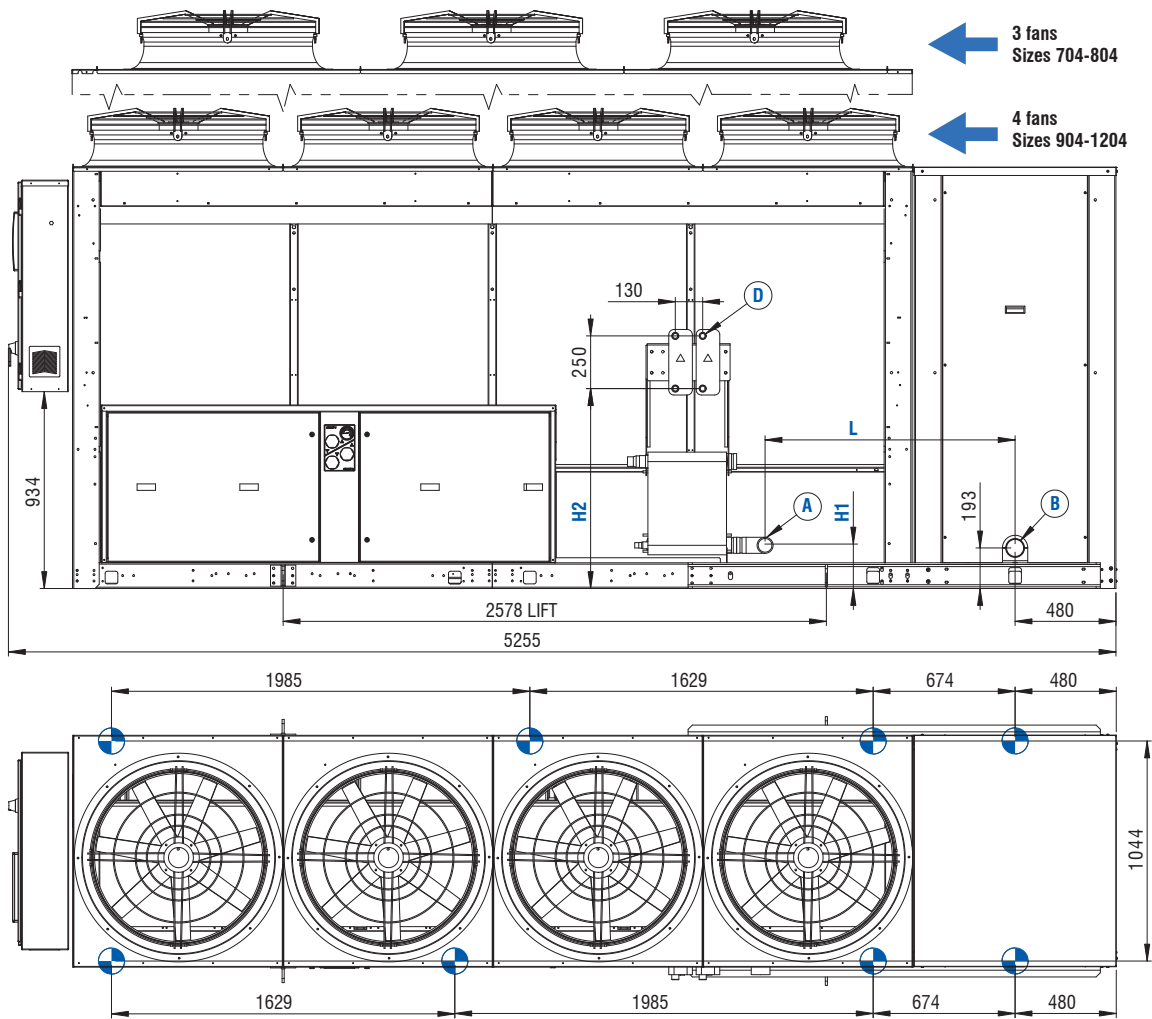

(**) Maximum with desuperheaters

Dimensions (mm)	704 - 804	904 - 1204
H1	205	213
H2	960	990
L	1186	1208

Water connections	704 - 804	904 - 1204
Water outlet "A"	2" 1/2 Male	3" Male
Water inlet "B" (with pump)	2" 1/2 Male	3" Male
Desuperheater in/out "D"	4 x 1" Male	4 x 1" Male

Space Requirements

Single unit applications

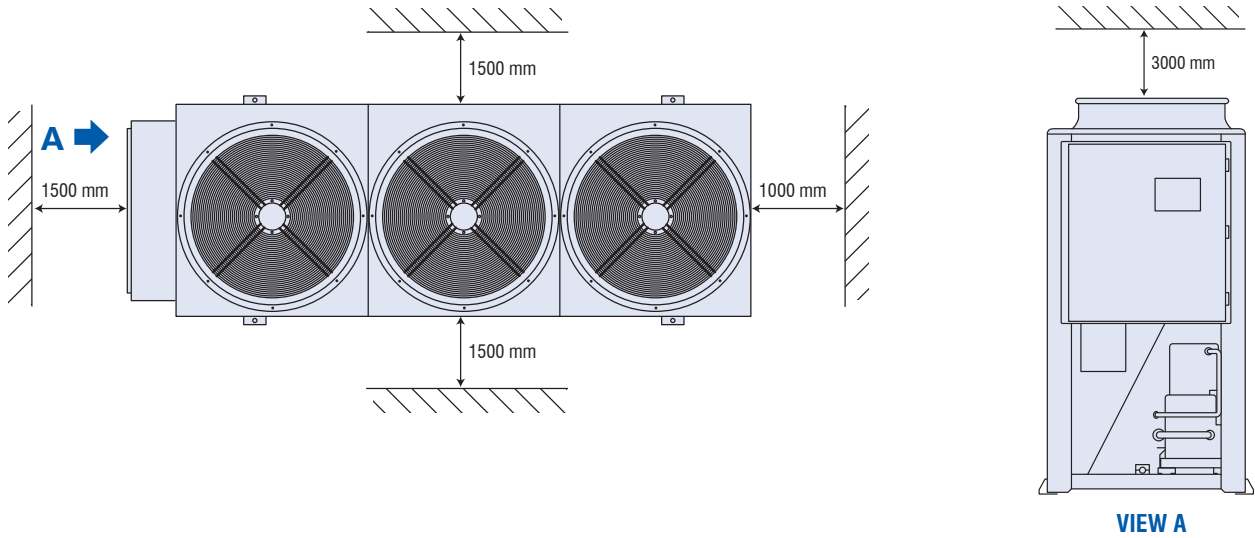

Multi units applications

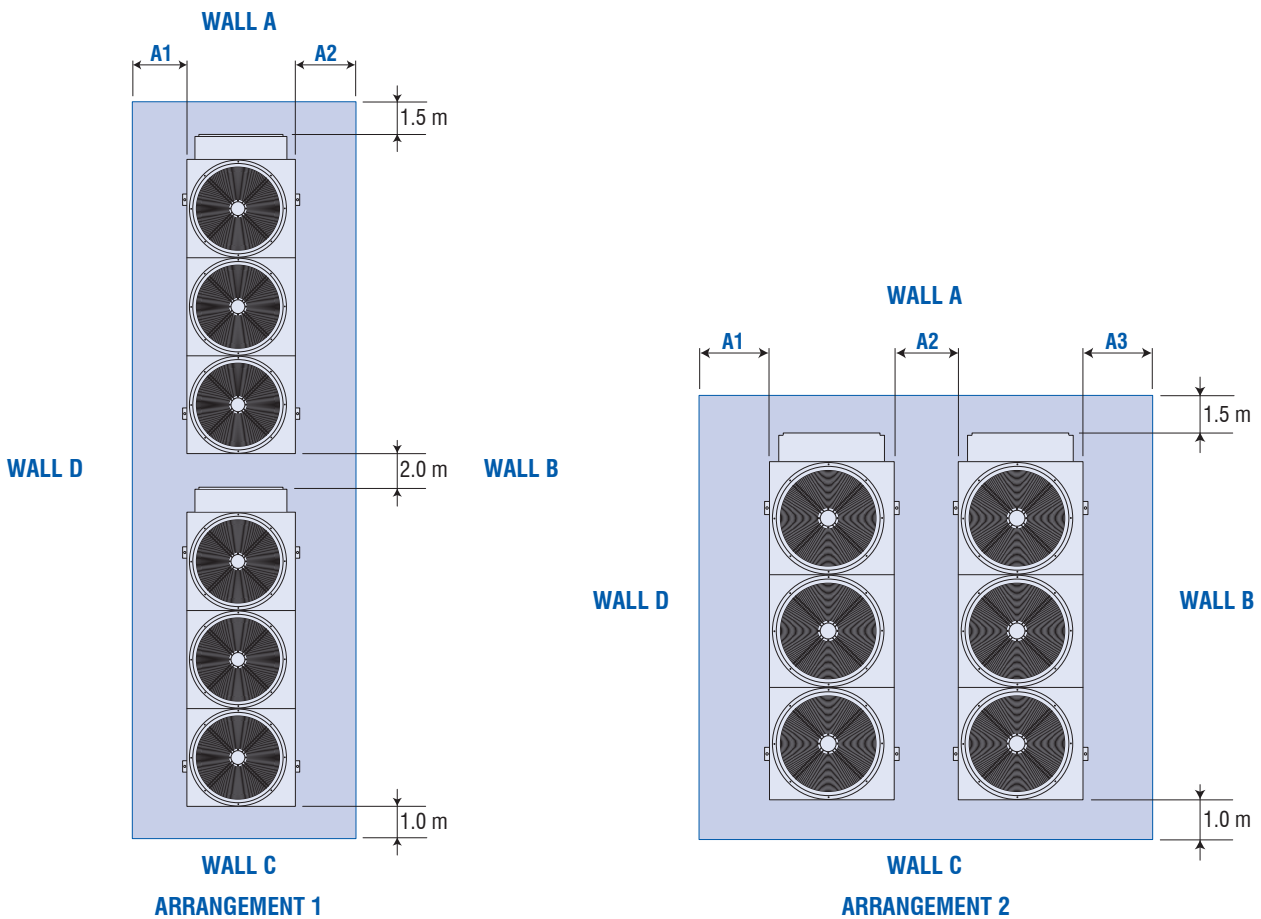

	LOUVRED A & C SOLID B & D			SOLID A & B SOLID C & D			SOLID A & C LOUVRED B & D			LOUVRED A & B SOLID C & D			LOUVRED A & D SOLID B & C		
	A1	A2	A3	A1	A2	A3	A1	A2	A3	A1	A2	A3	A1	A2	A3
ARRANGEMENT 1	1000	1000		1000	1000		800	800		1000	800		800	1000	
ARRANGEMENT 2	1000	1500	1000	1000	2000	1000	800	2000	800	1000	1500	800	800	1500	1000

Note : No more than one wall can be higher than the unit.
The area enclosed by the wall must be kept clear of all obstructions that would impede air flow to the unit. Dimensions in mm.

Systemair srl
Via XXV Aprile, 29
20825 Barlassina (MB)
Italy

Tel. +39 0362 680 1
Fax +39 0362 680 693

info@systemair.it