EX Centrifugal Explosion proof fan

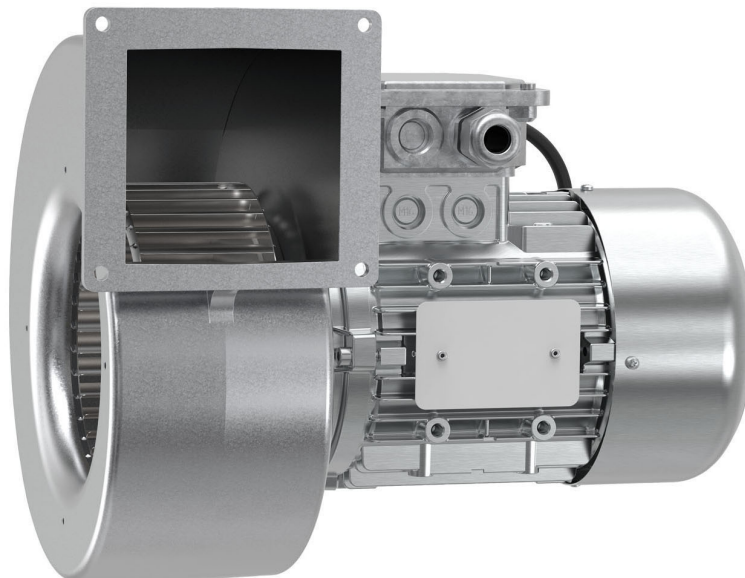

Table of contents

1	Introduction	1	14.1	Wiring diagram for motor protection for ATEX motors	18
1.1	Product description	1	14.2	Wiring diagram for speed controller for ATEX motors	19
1.2	Intended use	1	15	Accessory overview	20
1.3	Document description	1	16	EU Declaration of Conformity	21
1.4	Product overview	1			
1.5	Name plate	2			
1.5.1	Classification and Certification	2			
1.5.2	Type designation	3			
1.6	Product liability	3			
2	Safety	3			
2.1	Safety definitions	3			
2.2	Safety instructions	3			
2.3	Personal protective equipment	4			
3	Transportation and storage	4			
4	Installation	5			
4.1	To do before the installation of the product	5			
4.2	To install the product	5			
4.3	To connect the ducts to the product	6			
4.4	Requirements for frequency converter FCiC2 installation (accessory)	6			
5	Electrical connection	7			
5.1	To do before the electrical connection	7			
5.2	To connect the product to the power supply	7			
5.3	Control panel FCiC2 (accessory)	8			
6	Commissioning	9			
6.1	To do before the commissioning	9			
6.2	To do the commissioning	9			
7	Operation	10			
7.1	To start the product with a speed controller	10			
7.2	To start the product with a FCiC2	10			
7.3	To stop the product with speed controller	10			
7.4	To stop the product with FCiC2	10			
7.5	To stop the product in an emergency	10			
8	Maintenance	11			
8.1	Maintenance schedule	11			
8.2	To clean the product	11			
8.3	Spare parts	11			
9	Troubleshooting	12			
10	Disposal	13			
10.1	To disassemble and discard the parts of the product	13			
11	Warranty	14			
12	Technical data	15			
13	Product dimensions	16			
14	Wiring diagrams	17			

1 Introduction

1.1 Product description

The product is an explosion proof fan with a casing made from silumin alloy.

The product is not supplied with a safety switch, motor protection, external speed control, FCiC2 frequency converter or FK fast clamps, these parts are available and recommended as accessories.

1.2 Intended use

The product is used for transportation of air or explosive atmospheres with a maximum air humidity of 95%. Refer to the name plate for maximum temperature.

1.4 Product overview

The product is applicable for transportation of air that contains explosive or flammable media. The product is applicable for locations where there is a risk of explosion.

1.3 Document description

This document contains instructions for installation, operation and maintenance of the product. The procedures must be done by approved personnel only.

Speak to Systemair for more information on how to install the product in different installation locations.

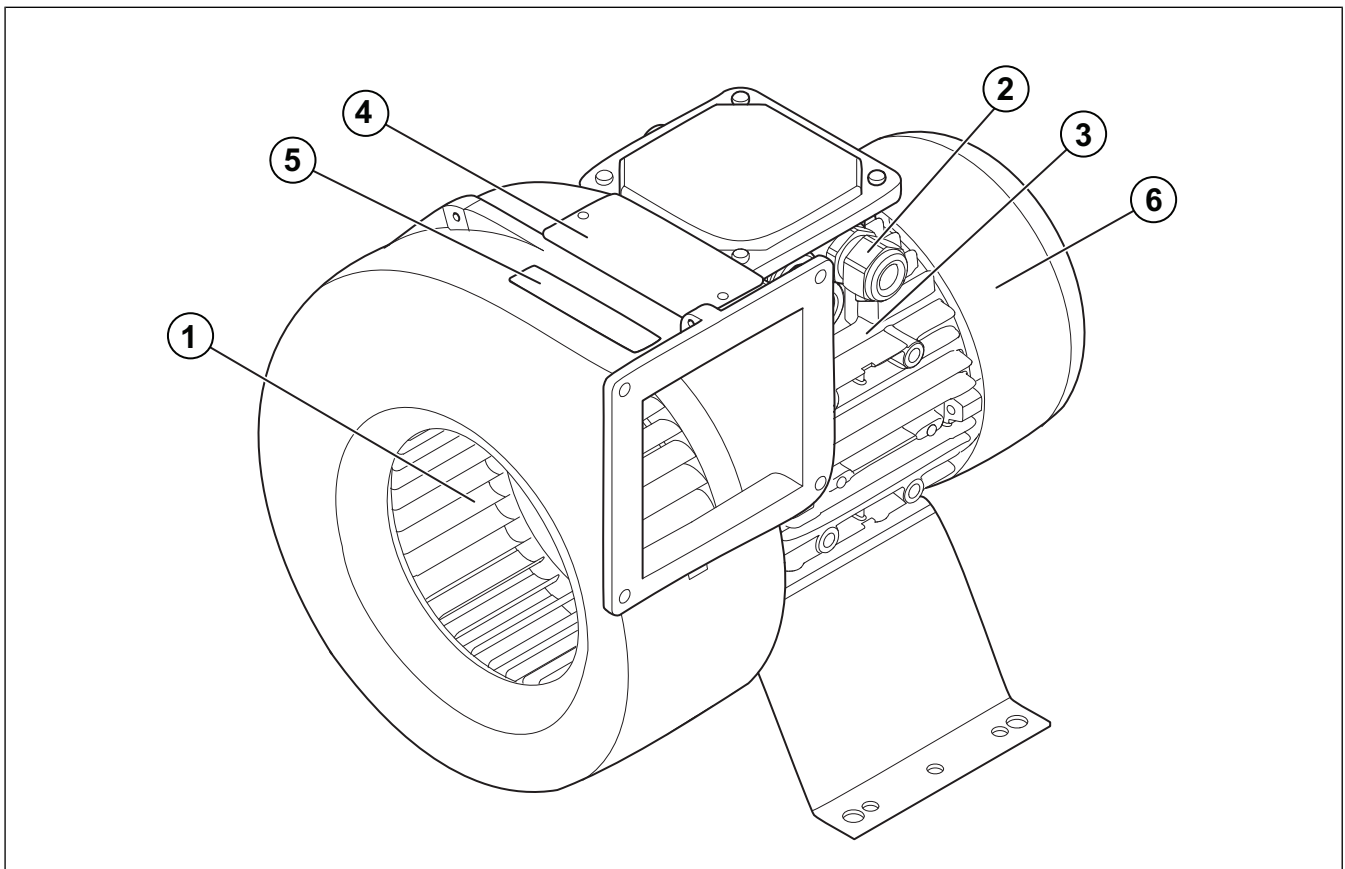

1. Fan impeller
2. Connection box
3. Motor data

4. Name plate
5. Production label
6. Casing

1.5 Name plate

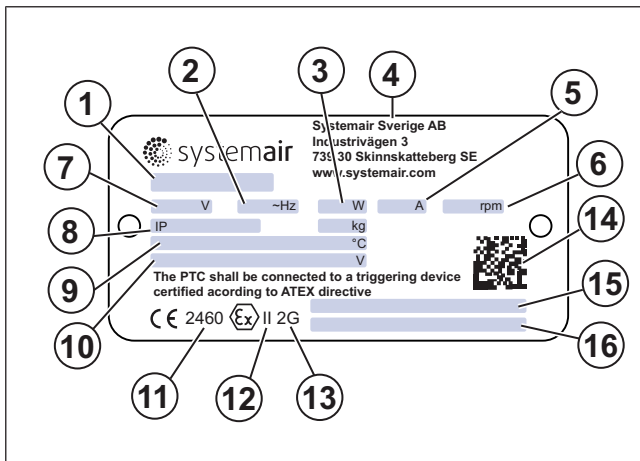

1. Type designation: Product name, dimension and motor type. Refer to [1.5.2 Type designation](#).
2. Frequency, Hz
3. Input power, W
4. Country of production
5. Current, A

6. Revolutions per minute
7. Voltage, V
8. IP class, enclosure class
9. Ambient temperature
10. Speed controllable
11. Identification number of Notified Body
12. Equipment group II is intended for use in areas with explosive gas, except mining gas.
13. Category 2, zone 1, G = potentially explosive gas mixture can be occasionally expected to during normal operation.
14. Scannable code ¹
15. Explosion proof classification. Refer to [1.5.1 Classification and Certification](#)
16. Certification number. Refer to [1.5.1 Classification and Certification](#)

Note:

The data on the name plate applies to “standard air” that is specified in the standard ISO5801.

1.5.1 Classification and Certification

Product name	Certification	Classification
EX 140–180	Presafe 16 ATEX 8598 X	Ex db eb h IIB + H ₂ T4 Gb

Ex db eb h IIB + H₂ T4 Gb



- A. Explosion-protected material
- B. Type of protection
- C. Gas group IIB + H₂
- D. Temperature class T4, maximum surface temperature for fan housing and motor is 135 °C, can be used for gas mixtures with ignition temperature exceeding 135 °C.
- E. EPL, Equipment Protection Level.

Specific conditions of use:

1. Thermal protection (PTC) in the motor windings must be connected to a protection device conforming to EN 50495.
2. For fans installed in a duct system, the degree of protection must be IP 20 at the inlet and outlet side conforming to EN 60529. Components which contribute to the enclosure protection must be of applicable design material and durability.
3. The supply voltage must be within the values specified in [12 Technical data](#).
4. Flameproof joints are not intended to be repaired.

1. Use a mobile device to scan the scannable code

1.5.2 Type designation

Product name	EX
Dimension	140A-2
	140-2C NC
	140A-4
	140-4C NC
	180A-4
	180-4C NC
Motor type	1-phase, 220 V
	1-phase, 230 V
	3-phase, 230 V
	3-phase, 380 V
	3-phase, 400 V
	3-phase, 415 V

1.6 Product liability

Systemair is not liable for damages that the product causes in these conditions:

- The product is incorrectly installed, operated or maintained.
- The product is used together with accessories that are not original accessories from Systemair.
- The product is used without motor protection.

2 Safety

2.1 Safety definitions

Warnings, cautions and notes are used to point out specially important parts of the manual.



Warning

If you do not obey these instructions, there is a risk of death or injury.



Caution

If you do not obey these instructions, there is a risk of damage to the product, other materials or the adjacent area.

Note:

Information that is necessary in a given situation.

2.2 Safety instructions



Warning

Read the warning instructions that follow before you do work on the product.

- Read this manual and make sure that you understand the instructions before you do work on the product.
- Obey local conditions and laws.
- The ventilation contractor and the operator are responsible for correct installation and intended use.
- Keep this manual at the location of the product.
- Do not install or operate the product if it is defective.
- Do not remove or disconnect safety devices.
- Make sure that you can read all warning signs and labels on the product when it is installed. Replace labels that have damage.
- Only permit approved personnel to work on the product and to be in the adjacent area during all work on the product.
- Make sure that you know how to stop the product quickly in an emergency.
- Use applicable safety devices and personal protective equipment during all work on the product.
- Before you do work on the product, stop the product and wait until the fan impeller stops. Make sure that there is no voltage on the motor terminals.
- If the maintenance is not correctly and regularly done, there is risk of injury and damage to the product.
- Only do the maintenance as given in this manual. Speak to Systemair technical support if other servicing is necessary.
- Sound levels exceeding 70 dB(A) may occur depending on model and size. Visit www.systemair.com for more detailed information about your product.
- The product is not to be used by persons, including children, with reduced physical, sensory or mental

capabilities, or lack of experience and knowledge, unless they have been given supervision or instruction.

- Do not allow children to play with the product.

2.3 Personal protective equipment

Use personal protective equipment during all work on the product.

- Approved eye protection
- Approved protective helmet
- Approved hearing protection
- Approved protective gloves
- Approved protective shoes
- Approved work clothing

3 Transportation and storage



Warning

Make sure that the product does not become damaged or wet during transportation. A damaged or wet product can cause fire or electric shock.

- Before you move the product to the installation location, examine the packaging for damages.
- Make sure that the impeller do not touch parts of the fan casing.
- Do not move the product by the cables, terminal box, fan impeller, protection grille or inlet cone.
- If lifting equipment is used, make sure that the lifting equipment can hold the weight of the product. Refer to the name plate for information. Do not lift the product by the packaging.



Warning

Do not walk below a lifted product.

- Keep the correct side of the packaging up during transportation. Refer to the arrows on the packaging.
- Load and unload the product carefully.
- Keep the product in a dry and clean location during storage. Make sure that the ambient temperature during storage is between -10 and $+30$ °C. A stable ambient temperature prevents damage from condensation.
- Keep the product in storage for maximum 1 year.

4 Installation



Warning

It is not permitted to install components with unprotected aluminium or steel surface before or after the product or in the direct air stream. To prevent an aluminothermic reaction, a surface protection is necessary that meet the crosscut test parameter of 2 / EN ISO 2409.



Warning

Rust particles must not be present in the air stream

Note:

Duct installations must be carried out so that enclosure class IP 20 (mesh width less than 12 mm) is fulfilled on the inlet and outlet side. Parts that assure the IP classification must be correctly designed with regard to strength and material.

Note:

All fans can be installed in any angle.

4.1 To do before the installation of the product

- Make sure that you have the necessary installation accessories:
 - Refer to [15 Accessory overview](#) for an overview of the accessories.
 - To decrease vibrations transmitted from the product to the duct system, Systemair recommends to install vibration dampers, fast clamps or flexible connections.
 - If you install the product with free suction or free discharge, it is necessary to install a protection grille. Make sure that the protection fulfils minimum IP 20 according to the standard EN 60529.
- Consider the ambient temperature, humidity, dirt in the environment and the air's corrosive properties.
- Use installation material with fire resistance rating for the installation location.
- Examine the packaging for transportation damage and remove the packaging from the product carefully.
- Examine the product and all components for damage.
- Make sure that the motor effect and the fan performance agrees with the expectations at the installation location.
- Make sure that the information on the name plate and the motor name plate agrees with the operation conditions.
- Install the product in a location where there is space for commissioning, troubleshooting and maintenance.
- Make sure that the installation location is clean and dry, for full safety during electrical work.
- Make sure that the installation surface has sufficient capacity to hold the weight of the product.
- Refer to the airflow direction arrows on the name plate or on the product to install the product in the correct position.
- Make sure that all cable glands are tight against the cables to prevent leaks.

4.2 To install the product

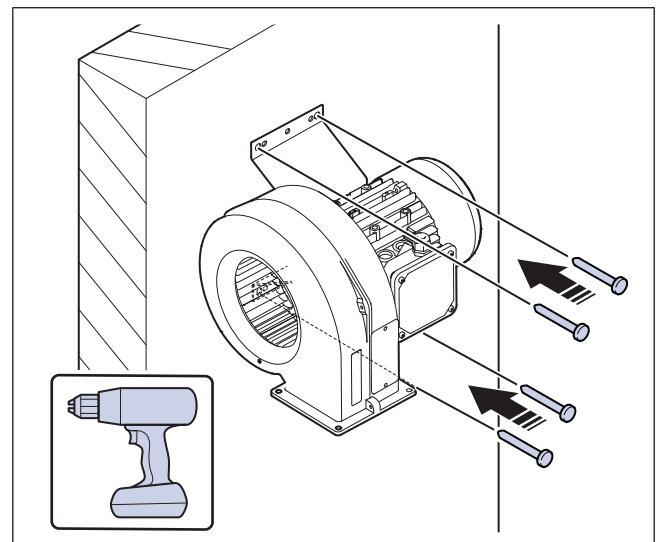

- 1 Install the product in any angle, using applicable installation equipment. Obey these steps when applicable:
 - If a motor air intake is mounted upwards, the intake must be protected against falling objects or liquid.
 - The motor is cooled by an integrated cooling fan, which openings must not be covered. Minimum distance to the air intake is 40 mm.
 - If the product is installed near a wall, keep a distance of minimum 400 mm from the product to the wall to prevent unwanted vibrations.

4.3 To connect the ducts to the product

Note:

Systemair recommends using the connection kit to connect the ducts to the fan. The connection kit is available as an accessory.

- 1 Put the ducts on each side of the product.
- 2 Use the sleeve connections on the outlet and inlet.

Note:

Installation example is only a guide for installation. The dimensioning of suspension devices must be carried by the installer and adapted to the prevailing conditions. Installation components mentioned in the text are accessories and not part of the ATEX certification.

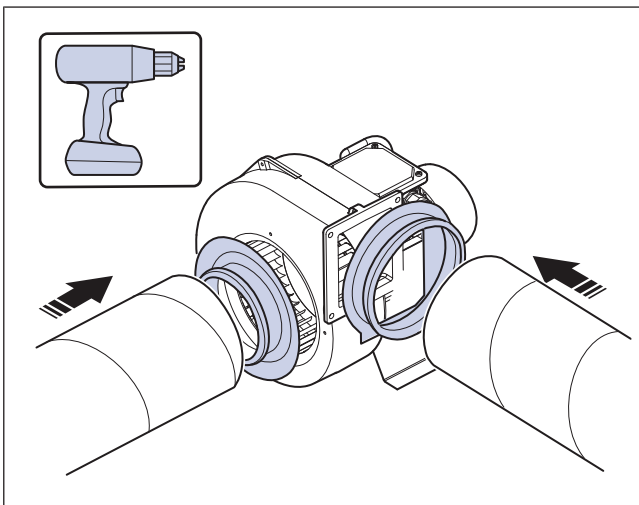

- 3 Attach the product with the supplied screws.

- 4 If you install the product near a duct bend, do these steps to prevent vibrations, unwanted noise and decreased air pressure:
 - a. Measure the distance (A) between the product and the duct bend.
 - b. Make sure that the distance (A) is a minimum of 2.5 x the diameter (B) of the duct system. For circular ducts, (B) is the nominal diameter. For rectangular ducts, (B) is the hydraulic diameter.

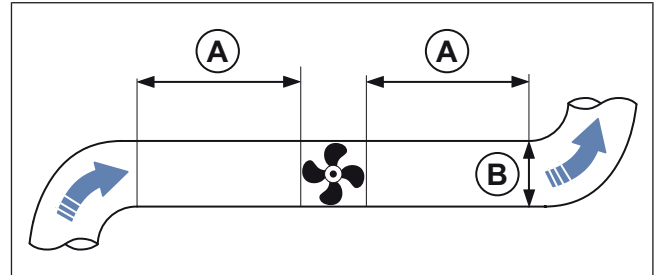

4.4 Requirements for frequency converter FCiC2 installation (accessory)

Note:

Only FCiC2 from Systemair is tested and approved for 3-phase EX fans.

Important:

- Install the FCiC2 outside the EX zone.
- The cable between the EX fan and the FCiC2 must be shielded.
- Maximum cable length is 5 m.
- Minimum installation clearance: Above and below, 100 mm, sides 0 mm for 40° C, 10 mm for 50° C.

Discharge time

- Stop the EX fan and disconnect the power supply.
- Make sure that the capacitors in the FCiC2 are fully discharged. Minimum waiting time is 4 minutes.

Unintended start

- Make sure that the EX fan does not start from control panel or I/O inputs when the FCiC2 is connected to the power supply.

Leakage current

- Leakage currents of the drive exceed 3.5 mA. Make sure that the minimum size of the ground conductor complies with the local safety regulations for high touch current equipment.

5 Electrical connection

5.1 To do before the electrical connection

- Make sure that the electrical connection agrees with the product specification on the motor name plate.
- Make sure that the environment for electrical connection is clean and dry.
- Make sure that the wiring diagram that is included with the supply of the product agrees with the terminals in the connection box.

5.2 To connect the product to the power supply

- Complete the electrical connection for the motor. Refer to [14 Wiring diagrams](#).
- Make sure that the cross section of the protective earthing is equal to or larger than the cross section of the phase conductor.
- Install a circuit breaker in the permanent electrical installation, with a contact opening of a minimum 3 mm at each pole.
- If a residual current device (RCD) is installed, make sure that it is an all-current sensitive RCD.



Warning

1-phase EX fans are not controllable.

Note:

ATEX approved motor protection is required. Systemair recommend U-EK230E motor protection.

5.3 Control panel FCiC2 (accessory)

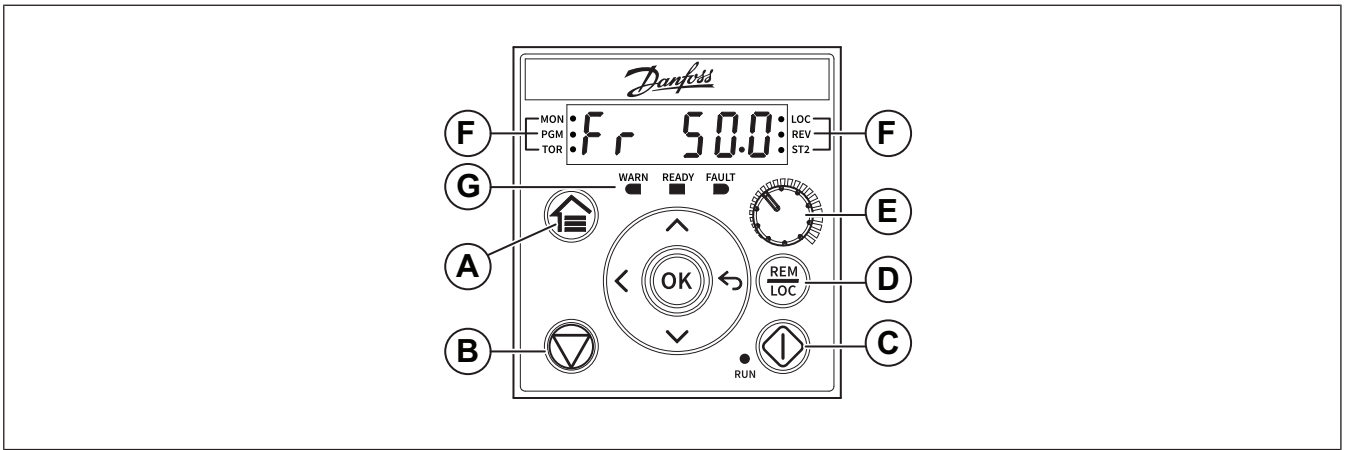

Table 1 Operation keys and potentiometer

	Name	Function	
A	Home	<ul style="list-style-type: none"> Toggles between status view and main menu. Long press to access the shortcut menu for quickly reading and editing parameters. 	
B		Stop the FCiC2 in local mode or reset to clear a fault	
C		Start in local mode	
D		Select between remote or local mode	
E	Potentiometer	Change the reference value	
F		Status indicator	
		Up	<ul style="list-style-type: none"> Navigates within the different screens and menus, and tunes the parameter values.
		Down	
		Left	
		Back	
	OK	Confirms selections and data in the control panel display.	

Table 2 Status indicator lights

Name	Function
MON	On Shows the FCiC2 status.
LOC	On The FCiC2 is in local mode.
	Off The FCiC2 is in remote mode.
ST2	On The FCiC2 is in 60 Hz

Table 3 Run indicator light

Name	Function
WARN	Steadily lit when a warning occurs.
READY	Steadily lit when the drive is ready.
FAULT	Flashes when a fault occurs.

6 Commissioning



Caution

- If strong vibrations occur during commissioning, immediately increase or decrease the fan speed until the vibrations are decreased. Continuous strong vibrations can cause damage to components.
- Do not increase the fan speed to a higher rpm value than the maximum value that is given on the name plate.

The commissioning report is found at www.systemair.com.

6.1 To do before the commissioning

- Make sure that the installation and electrical connection are correctly done.
- Make sure that PTC resistors and monitoring units are professionally connected and fully functional.
- Verify that connection data corresponds with the data on the rating plate: Max. voltage +6%, -10%, according to IEC 38. Rated current/power must not be exceeded at rated voltage.
- The voltage of controllable fans is permitted to vary between 15% and 100% of nominal voltage with a transformer. Refer to transformer steps in [12 Technical data](#).
- Frequency controllable fans, frequency minimum 10Hz, refer to the name plate [1.5 Name plate](#) for maximum limit.
- Make sure that the motor protection function.
- Make sure that the impeller do not hit parts of the fan housing.
- Visually examine the product and accessories for damage.
- Make sure that the safety devices are correctly installed.
- Make sure that there are no blockages in the air intake and the air outlet.
- Make sure that installation material and unwanted objects are removed from the product and the ducts.

6.2 To do the commissioning

- 1 Set the installed safety switch in the OFF position.
- 2 If it is possible to get access to the fan impeller, do the steps that follows:
 - a. If it is necessary, remove parts of the installation.
 - b. Turn the fan impeller by hand and make sure that it turn easily.
 - c. Record the result in the commissioning report.

- 3 Make sure to turn the product in a direction that agrees with the related arrow on the product.
 - a. Record the result in the commissioning report.
- 4 If you removed parts of the installation to get access to the fan impeller, install the removed parts again.
- 5 Set the installed safety switch in the ON position.
- 6 Start the product.
- 7 Set the minimum operation speed.
- 8 Increase the operation speed gradually to the maximum operation speed.
 - a. Examine the vibrations in the casing and the bearing areas at all speed levels.
 - b. Make sure that the vibrations agree with the specifications in ISO 14694.
 - c. Make sure that none of the speed levels cause unwanted noise in the product.
 - d. Record the result in the commissioning report.
- 9 Record the necessary data in the commissioning report.

7 Operation

7.1 To start the product with a speed controller



Warning

1-phase EX fans are not controllable.

- 1 Set the speed controller to position "0".
- 2 Install the external speed controller. Refer to the instruction manual for the installed speed controller.

7.2 To start the product with a FCiC2

- 1 Install the FCiC2. Refer to [4.4 Requirements for frequency converter FCiC2 installation \(accessory\)](#) for installation requirements.
- 2 Set the installed safety switch in the ON position.
- 3 Adjust the fan speed with the FCiC2 (local mode) or with the potentiometer (remote mode).
 - If an external potentiometer is installed, adjust the fan speed directly with the potentiometer. It is also possible to install an external on/off switch to FCiC2 and the potentiometer, refer to [14 Wiring diagrams](#).

7.3 To stop the product with speed controller

- 1 Set the speed controller to position "0".
- 2 Set the installed safety switch in the OFF position.

7.4 To stop the product with FCiC2

- 1 FCiC2 in
 - a. local mode, press stop button.
 - b. remote mode, turn the potentiometer to 0V.
- 2 Set the installed safety switch in the OFF position.

7.5 To stop the product in an emergency

- Set the installed safety switch in the OFF position.

8 Maintenance



Warning

Set the installed safety switch in the OFF position before you do the maintenance unless the instructions tell you differently. Make sure that the safety switch is not accidentally set in the ON position.

8.1 Maintenance schedule

The intervals are calculated from continuous operation of the product.

Maintenance task	Usual operation conditions		Unusual operation conditions. ¹		
	Each 6 months	Each year	Each 3 months	Each 6 months	Each year
Visually examine the product and its components for damage, corrosion and dirt.		X		X	
Examine the fan impeller for damage and imbalance.		X		X	
Clean the product and the ventilation system.	X		X		
Do a check of all fasteners and make sure that they are fully tightened.		X			X
Make sure that the product and its components are correctly operated.	X			X	
Measure the power consumption and compare the result with the information on the name plate.		X		X	
If vibration dampers are installed, make sure that they operate correctly and examine them for damage and corrosion.		X			X
Make sure that the electrical protective equipment and the mechanical protective equipment operates correctly.		X			X
Make sure that you can read the name plates of the product.		X		X	
Examine all cable connections for damage. Make sure that the cable glands are tight against the cables.		X			X
If flexible connections are installed, examine them for damage.	X			X	

1. The unusual operation conditions are classified as follows: If a stable ambient temperature is higher than 30 °C or lower than -10° C, if the temperature changes are large or if very contaminated air is transported.

8.2 To clean the product



Caution

- Do not clean the product with a high-pressure washer.
- Do not clean the product with steel brushes or sharp objects.
- Do not bend the fan impeller blades.
- Be careful not to move the balance weights on the fan impeller.

- Remove dirt from the fan and the duct.
- If access to the fan impeller is possible, clean the fan impeller with a moist cloth or soft brush.

8.3 Spare parts

Note:

Repair or replacement of components is not permitted on EX fans.

9 Troubleshooting

Note:

If you cannot find a solution to your problem in this section, speak to Systemair technical support.

Problem	Cause	Solution
The product does not operate smoothly.	The fan impeller is not correctly balanced.	Speak to Systemair technical support.
	There is dirt on the fan impeller.	Clean the fan impeller carefully. Refer to 8.2 To clean the product .
	The fan impeller has damages or deformations because the transported air contains aggressive media.	Speak to Systemair technical support.
	The fan impeller does not turn in the correct direction.	Make sure that the electrical connection is correctly done.
	The fan impeller has deformations because of too high temperatures.	<ul style="list-style-type: none"> • Make sure that the temperature of the transported air is not higher than the value on the name plate. • Replace the product.
	There are unusually strong vibrations in the product or the duct system.	Make sure that the product is correctly installed. Do a check of the duct system.
	The product is operated in a resonant frequency range.	Increase or decrease the fan speed until the product operates smoothly. Refer to 6 Commissioning .
The air output is not sufficient.	The fan impeller does not turn in the correct direction.	Make sure that the electrical connection is correctly done.
	The electrical connection is not correctly done.	Make sure that the electrical connection agrees with the wiring diagrams.
	The air pressure is too low because of incorrect installation.	Do the necessary changes in the duct system and installed components to increase the air pressure. Refer to 6 Commissioning .
	The spring return damper on outdoor or exhaust duct is closed or not fully open.	Adjust the spring return damper.
	There is blockage in the air inlet or the duct system.	Remove the blockage.
	The product is not applicable for the installation location.	Make sure that the product is applicable for the installation location.
There is unusual noise when the product starts or operates.	There is strain in the connections of the duct system.	Loosen the connections, align the parts of the duct system correctly and tighten the connections.

Problem	Cause	Solution
Thermal contacts, PTC or resistors are released.	The fan impeller does not turn in the correct direction.	Make sure that the electrical connection is correctly done.
	A phase loss occurred.	If the motor is a 3-phase motor, make sure that no phase is missing.
	The motor is overheated.	<ul style="list-style-type: none"> Do a check of the motor cooling impeller. If it is possible, measure the resistance to do a check of the motor winding.
	The capacitor is not connected or not correctly connected.	Connect the capacitor correctly. Refer to the included motor wiring diagram.
	There is blockage in the motor.	Speak to Systemair technical support.
The fan speed does not get the nominal value.	Defective motor winding.	If it is possible, measure the resistance to do a check of the motor winding.
	The speed control is not correctly set.	Set the speed control correctly.
	The fan impeller cannot turn freely because of mechanical blockage.	Remove the blockage.
	Phase loss occurs.	If the motor is a 3-phase motor, make sure that no phase is missing.
The motor does not rotate.	A component in the power supply is defective.	Do a check of the power supply. Replace defective components and connect the power supply again.
	The electrical connection is not correctly done.	Make sure that the electrical connection agrees with the wiring diagrams.
	The motor protection is released because the motor is overheated.	Let the motor become cool. Reset the motor protection. Find the cause of the overheated motor.
	A phase loss occurred.	If the motor is a 3-phase motor, make sure that no phase is missing.
The electronic components or the motor is overheated.	The motor is overloaded or the ambient temperature is too high.	Let the motor become cool. Reset the motor protection. Find the cause of the overheated motor.
	The motor is overloaded.	Make sure that the product is applicable for the installation location.
	The ambient temperature is too high.	Make sure that the product is applicable for the installation location.
	The cooling of the product is not sufficient.	Make sure that the space around the motor is sufficient to keep the temperature down.

10 Disposal

The product follows the WEEE directive. This symbol on the product or the packaging of the product shows that this product is not domestic waste. The product must be recycled at an approved disposal location for electrical and electronic equipment.

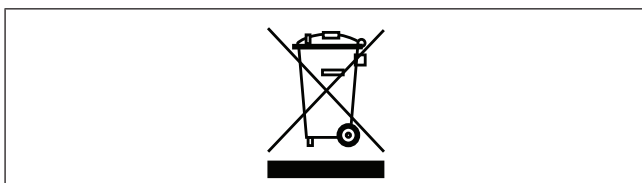

10.1 To disassemble and discard the parts of the product

- 1 Disconnect and disassemble the product in the opposite sequence of electrical connection and installation.
- 2 Recycle the product parts and the packaging at an applicable disposal location.
- 3 Obey the local and national requirements for disposal.

11 Warranty

For warranty claims, send a written maintenance plan and the commissioning report to Systemair. The warranty is only applicable for these conditions:

- The product is correctly installed and operated.
- Motor protection is used.
- The instructions in the data sheets are obeyed.
- Maintenance instructions are obeyed.
- The product is operated for a minimum of 1 hour each month.

12 Technical data

1-phase Not controllable

	EX140-2C NC	EX 140-4C NC		EX 180-4C NC	
Voltage	220–240V 1~	220–240V 1~	220–240V 1~	220–240V 1~	220–240V 1~
Frequency (Hz)	50	50	60	50	60
P (W)	755	200	294	263	305
I (A)¹	3.40	0.9	1.35	1.13	1.35
rpm (min-max)	2800–2973	1465–1486	1746–1794	1437–1485	1675–1793
Isol class	F				
Weight (kg)	10.7	6.7		6.9	
Min. flow (m³/h)	100				
Max. flow (m³/h)	1160	660	785	915	860
Min. Pressure (Pa)	90	-	-	-	160
Ambient temp.	–20 °C to +50 °C				

1. The current may exceed the rated current on the fan label as long as the total power consumption does not exceed the rated power value given.

3-phase Speed controllable

	EX 140A-2		EX 140A-4			EX 180A-4		
Voltage	230V(D) 3~	380–415V (Y) 3~	230V(D) 3~	380–415V (Y) 3~	380–440V (Y) 3~	230V(D) 3~	380–415V (Y) 3~	380–440V (Y) 3~
Frequency (Hz)	10–50	10–50	10–50	10–50	10–60	10–50	10–50	10–60
P (W)	725	736	171	178	232	248		364
I (A)¹	2.44	1.46	1.2	0.73	0.64	1.25	0.73	0.7
rpm (min-max)	1229–2988		820–1490		709–1805	611–1486		491–1801
Isol class	F							
Weight (kg)	10		6.3			6.4		
Min. flow (m³/h)	100							
Max. flow (m³/h)	1181		610	644	722	875	869	1049
Ambient temp.	–20 °C to +60 °C			–20 °C to +50 °C				

1. The current may exceed the rated current on the fan label as long as the total power consumption does not exceed the rated power value given.

Transformer steps	1	2	3	4	5
Voltages 3~	95V	145V	190V	240V	400V

13 Product dimensions

Note:

If the unit of measure is not specified, the dimensions are given in millimetres.

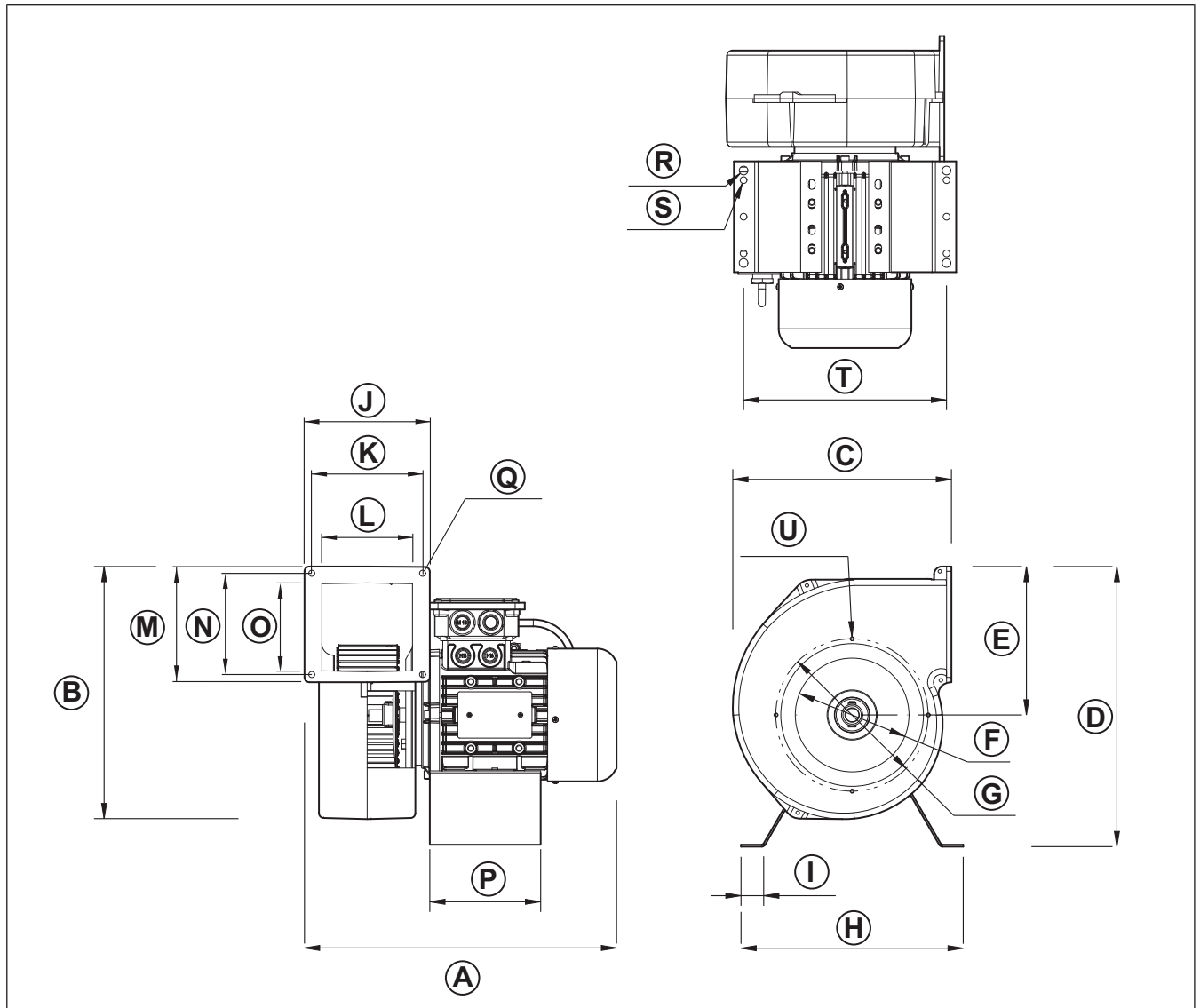

	A	B	C	D	E	F	G	H	I	J	K
EX 140A-4 EX 140-4C NC	301	262	227	285	154	118	158	211	23.5	130	115
EX 180A-4 EX 180-4C NC	314	294	261	302	171	149	194	211	23.5	125	110
EX 140A-2 EX 140-2C NC	324	262	227	291	154	118	158	231	23.5	130	115

	L	M	N	O	P	Q	R	S	T	U
EX 140A-4 EX 140-4C NC	94	120	105	92	115	∅6 (4x)	∅9(4x)	∅7(6x)	191.5	M4(4x)
EX 180A-4 EX 180-4C NC	86	140	120	109	115	∅7(4x)	∅9(4x)	∅7(6x)	191.5	M4(4x)
EX 140A-2 EX 140-2C NC	94	120	105	92	115	∅6 (4x)	∅9(4x)	∅7(6x)	210.5	M4(4x)

14 Wiring diagrams

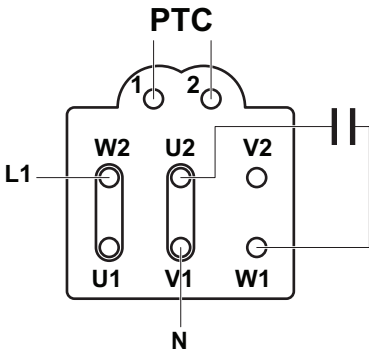
EX fans	1-phase 220–240 V	
EX 140-2C NC		
EX 140-4C NC		
EX 180-4C NC		

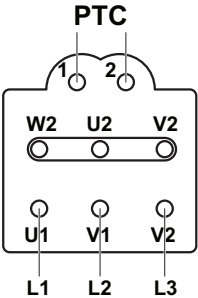
EX fans	3-phase 380–440 V (Y)	3-phase 230 V (D)
EX 140A-2		
EX 140A-4		
EX 180A-4		

14.1 Wiring diagram for motor protection for ATEX motors

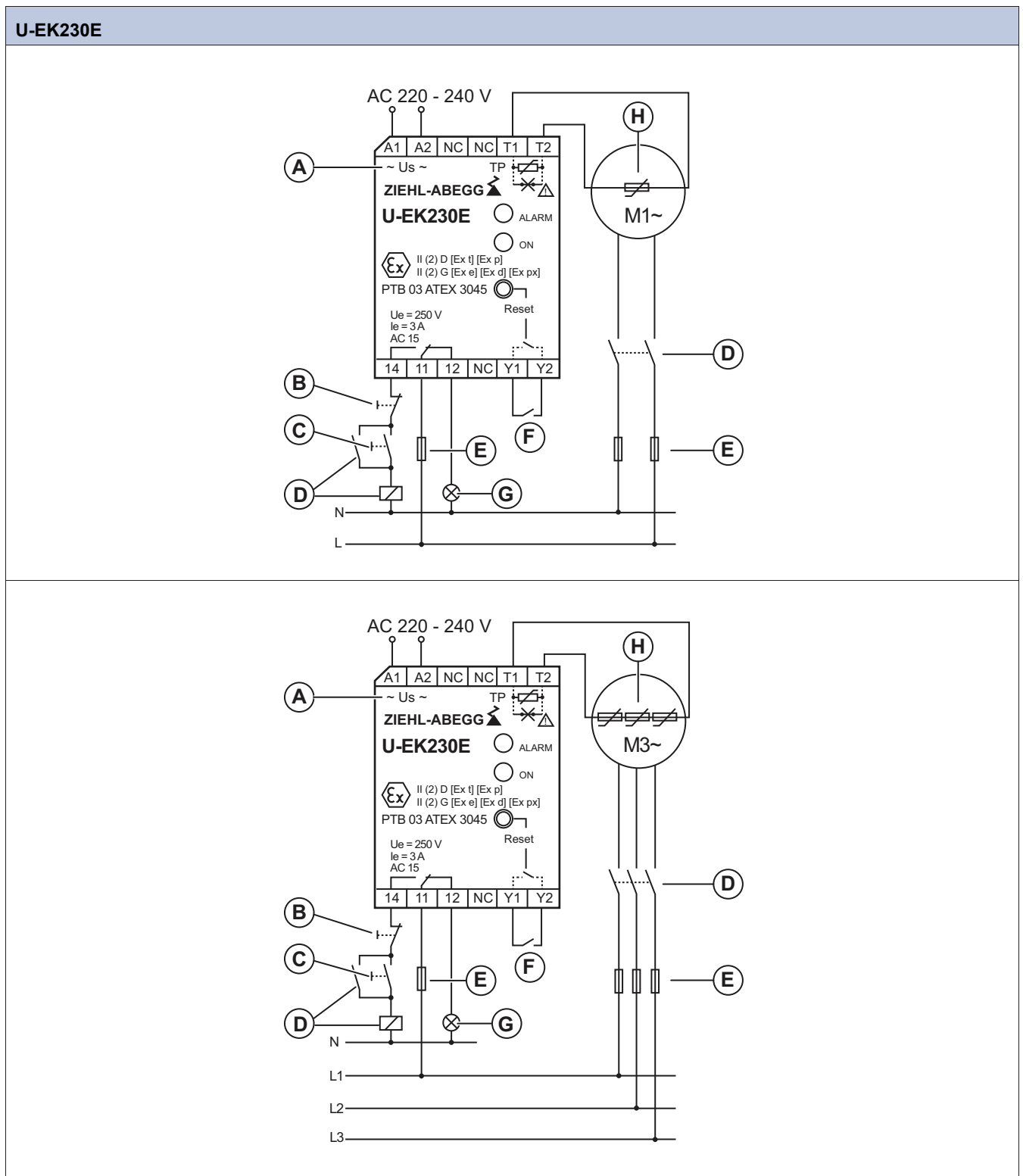

- A. Supply voltage (Us)
- B. Push button off (S1)
- C. Push button on (S2)
- D. Contactor (K1)
- E. Fuses (F1–F4)
- F. Push button external reset (S3)
- G. Fault indicator (H1)
- H. PTC termistor (TP)

14.2 Wiring diagram for speed controller for ATEX motors

U-EK230E + FCiC2

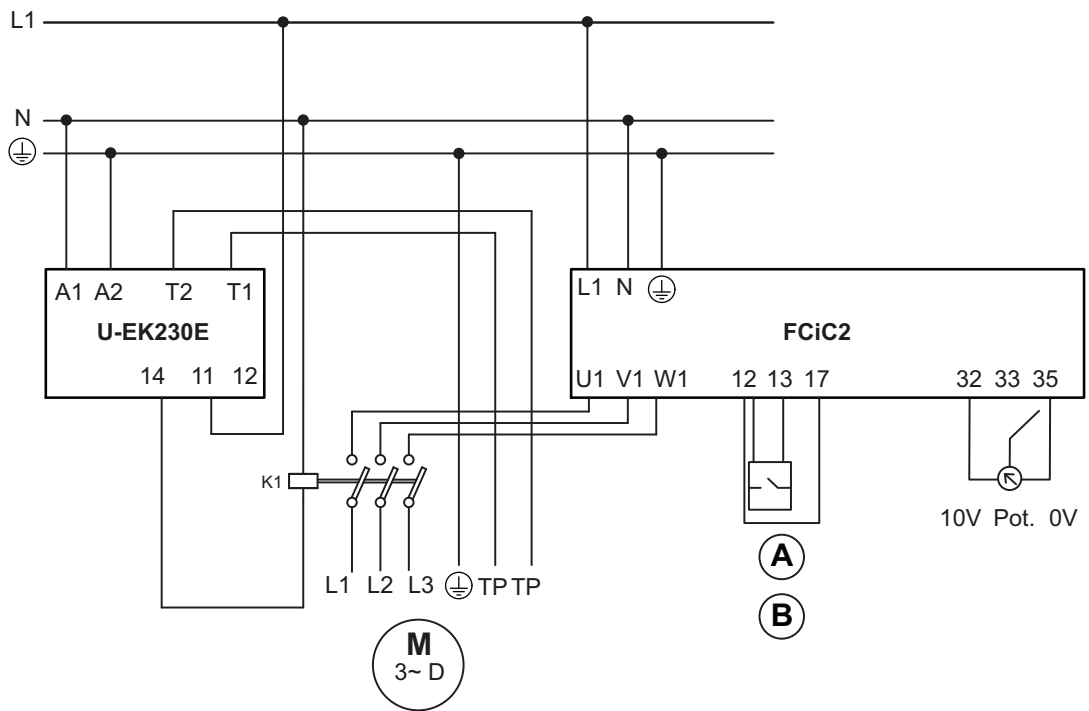

A. 12–13 Digital start signal

B. 12–17 Bridged for 60 Hz

U-EK230E + RTRD, RTRDU

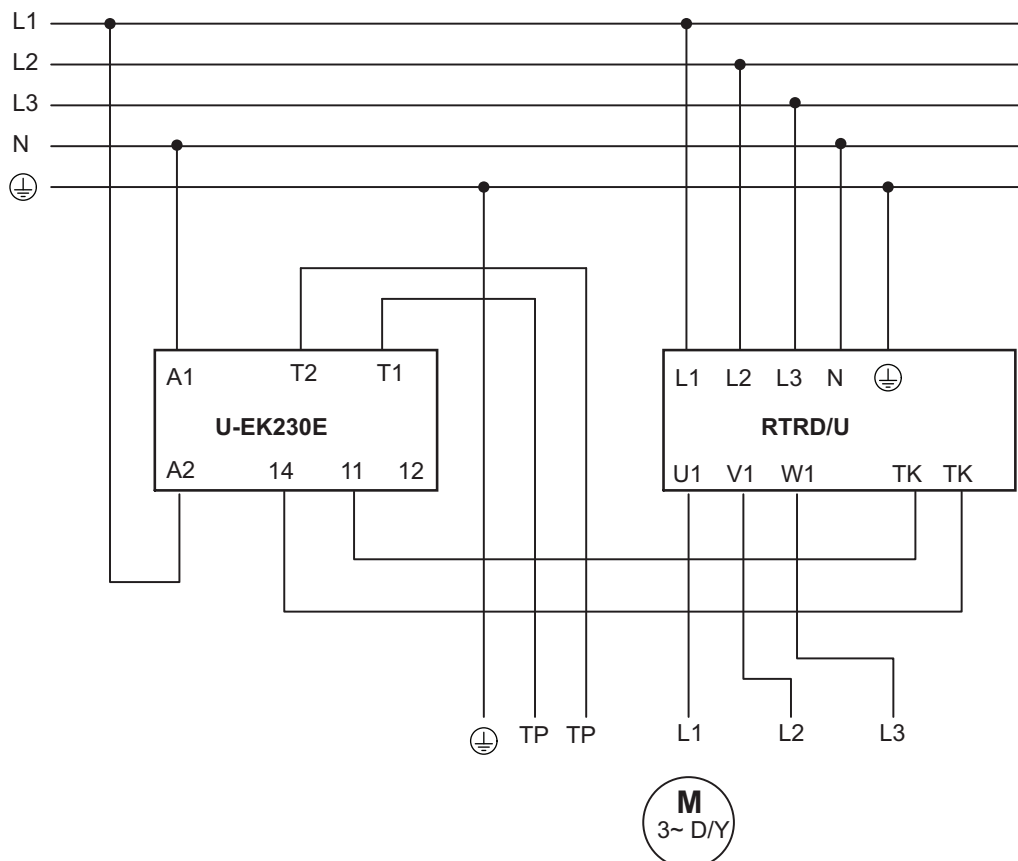

15 Accessory overview

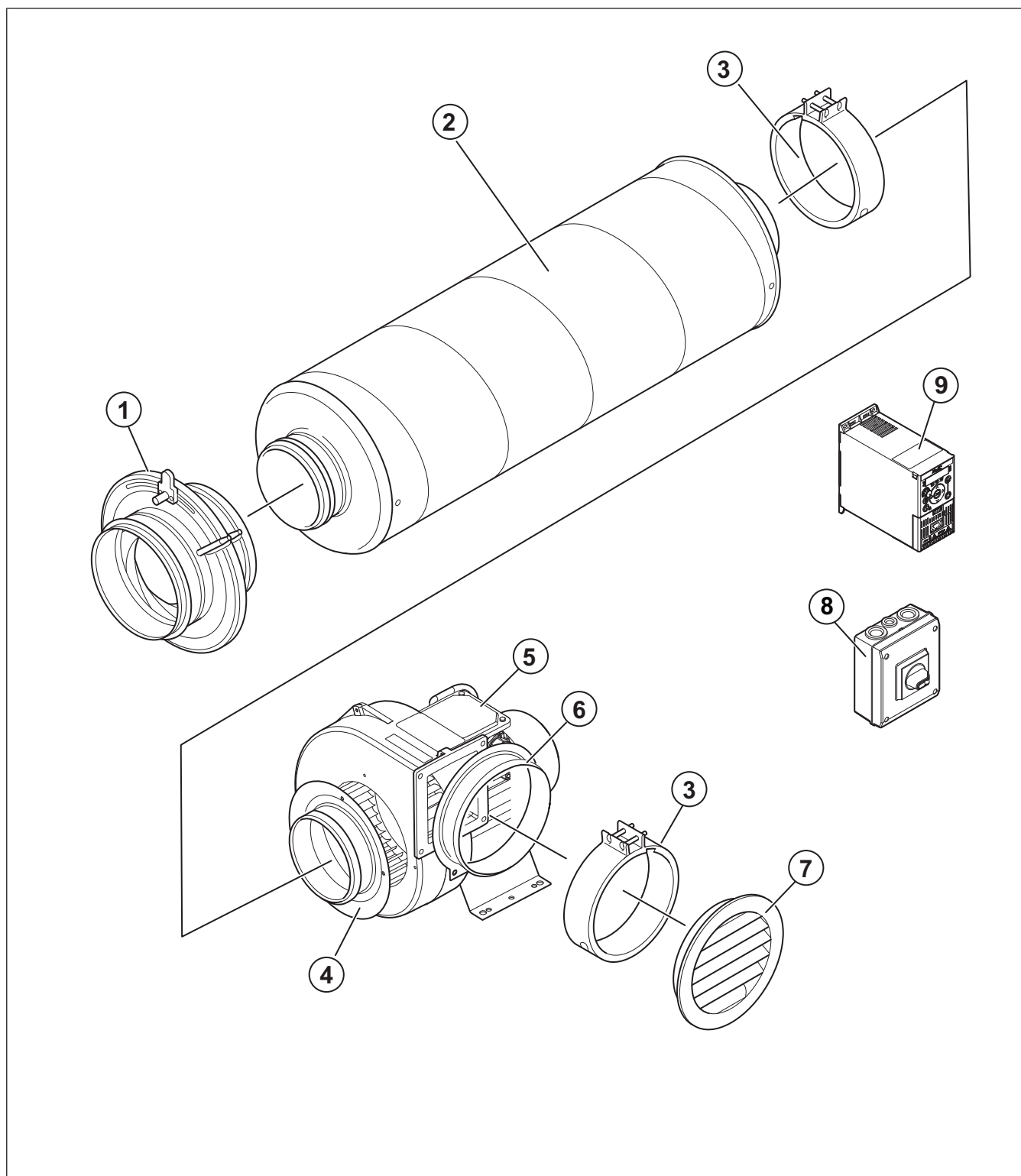

- 1. SPI: Iris damper
- 2. LDC: Silencer
- 3. FK: Fast clamp
- 4. IS: Inlet sleeve connection
- 5. Fan

- 6. US: Outlet sleeve connection
- 7. IGC: Wall grid
- 8. Safety switch
- 9. FCiC2: Frequency converter

Note:

The selection of accessories shown are not supplied with the product. For more information and other available accessories, refer to www.systemair.com or speak to Systemair technical support.

16 EU Declaration of Conformity

We, the manufacturer

Manufacturer	Systemair Production AB
Address	Industrivägen 3 739 30 Skinnskatteberg Sweden

declare under our sole responsibility that the products

Machine	Explosion proof fan
Type/Model	EX
Notified body	Number 2460, DNV Product Assurance AS

fulfils the relevant provisions of following directives and standards

ATEX Directive 2014/34/EU

EN IEC 60079-0:2018

Explosive atmospheres – Part 0: Equipment – General requirements.

EN 60079-1:2014

Explosive atmospheres – Part 1: Equipment protection by flameproof enclosures “d”.

EN IEC 60079-7:2015/A1:2018

Explosive atmospheres – Part 7: Equipment protection by increased safety “e”.

EN 14986:2017

Explosive atmospheres – Design of fans working in potentially explosive atmospheres.

Machinery Directive 2006/42/EC

EN ISO 12100:2010

Safety of machinery – General principles for design – Risk assessment and risk reduction.

EN ISO 13857:2019

Safety of machinery – Safety distances to prevent hazard zones being reached by upper or lower limbs.

EN 60529:2014

Degrees of protection provided by enclosures (IP Code).

Directive electromagnetic compatibility (EMC) 2014/30/EU

EN 61000-6-2:2005

Electromagnetic compatibility (EMC) – Part 6-2: Generic standards – Immunity for industrial environments.

EN 61000-6-3:2007

Electromagnetic compatibility (EMC) – part 6-3: Generic standards – emission standard for residential, commercial and light-industrial environments.

RoHS Directive 2011/65/EU

EN IEC 63000:2018

Technical documentation for the assessment of electrical and electronic products with respect to the restriction of hazardous substances

Persons authorized to compile the technical file:



Tomas Angelhag

Head Of Engineering

This declaration relates exclusively to the machinery in the state in which it was placed on the market and excludes components which are added or operations carried out subsequently by the final user.

Skinnskatteberg, Sweden 2024-12-17



Sofia Rask

Managing Director



Systemair Production AB
Industrivägen 3
SE-739 30 Skinnskatteberg

+46 222 440 00
mailbox@systemair.com
www.systemair.com

© Copyright Systemair AB
All rights reserved
EOE

Systemair AB reserves the rights to alter their products without notice. This also applies to products already ordered, as long as it does not affect the previously agreed specifications.