

Installation and maintenance manual
Manuel d'installation et de maintenance
Installations- und Wartungshandbuch
Manuale di installazione e di manutenzione
Manual de instalación y de mantenimiento

SYSCROLL 20-35 Air CO/RE



English

Français

Deutsch

Italiano

Español



20
↓
33 kW



Air Cooled Water Chillers
Refroidisseurs de Liquid à Condensation par l'Air Eau/Eau
Luftgekühlte Flüssigkeitskühler
Refrigeratori d'Acqua Raffreddati ad Aria
Enfriadores de Agua Condensadascon Aire

Part number / Code / Code / Codice / Código: **361790/G**
Supersedes / Annule et remplace / Annulliert und ersetzt / Annulla e sostituisce /
Anula y sustituye: **361790/F**
Notified Body / Organisme Notifié / Benannte Zertifizierungsstelle /
Organismo Notificato / Organismo Notificado N°. **0425**



ISO 9001:2015 certified management
system

Table of Contents

1 - FOREWORD

| | |
|--|---|
| 1.1 Introduction..... | 2 |
| 1.2 Warranty..... | 2 |
| 1.3 Emergency stop / Normal stop | 2 |
| 1.4 An introduction to this manual | 2 |

2 - SAFETY

| | |
|---|---------|
| 2.1 Foreword..... | 3 |
| 2.2 Definitions..... | 4 |
| 2.3 Access to the unit | 4 |
| 2.4 General precautions..... | 4 |
| 2.5 Precautions against residual risks | 4 |
| 2.6 Precautions during maintenance operations | 5 |
| 2.7 Safety labels | 6 & 8 |
| 2.8 Safety regulations..... | 9 to 11 |

3 - TRANSPORT, HANDLING AND STORAGE

| | |
|----------------------|----|
| 3.1 Inspection | 12 |
| 3.2 Handling | 12 |
| 3.3 Anchoring | 13 |
| 3.4 Storage..... | 13 |

4 - INSTALLATION

| | |
|---------------------------------|----------|
| 4.1 Installation site | 14 |
| 4.2 External water circuit..... | 14 to 15 |
| 4.3 Water connections | 16 |
| 4.4 Water buffer tank | 16 & 17 |
| 4.5 Power supply | 17 |
| 4.6 Electrical connections..... | 18 to 20 |

5 - START-UP

| | |
|-----------------------------------|----|
| 5.1 Preliminary checks..... | 21 |
| 5.2 Start-up | 21 |
| 5.3 Checking the operation..... | 21 |
| 5.4 Delivery to the customer..... | 21 |

6 - CONTROL

| | |
|---|----|
| 6.1 Control of a single compressor unit | 22 |
| 6.2 Keypad functions | 22 |
| 6.3 Folder structure..... | 23 |
| 6.4 Menu structure..... | 23 |
| 6.5 Alarm list | 24 |

7 - PRODUCT DESCRIPTION

| | |
|----------------------------------|---------|
| 7.1 General information..... | 25 |
| 7.2 Accessories | 26 & 27 |
| 7.3 Refrigeration circuits | 28 & 29 |

8 - TECHNICAL DATA

| | |
|--|----------|
| 8.1 Hydraulic features | 30 |
| 8.2 Physical data..... | 31 to 32 |
| 8.3 Electrical data..... | 33 |
| 8.4 Position of shock adsorbers and weight distribution on supports | 34 |
| 8.5 Dimensional Drawings SYSCROLL 20-35 CO/RE | 35 |
| 8.6 Dimensional Drawings SYSCROLL 20-35 CO + HYDROKIT | 36 |
| 8.7 Space requirements | 37 |

9 - MAINTENANCE

| | |
|---------------------------------------|----|
| 9.1 General requirements | 38 |
| 9.2 Planned maintenance | 38 |
| 9.3 Refrigerant charge..... | 39 |
| 9.4 Compressor..... | 39 |
| 9.5 Condenser | 39 |
| 9.6 Fans | 39 |
| 9.7 Dehydrating filter..... | 39 |
| 9.8 Sight glass..... | 40 |
| 9.9 Thermostatic expansion valve..... | 40 |
| 9.10 Evaporator | 40 |

10 - TROUBLESHOOTING

| | |
|--------------------------|----|
| 10 Troubleshooting | 41 |
|--------------------------|----|

11 - SPARE PARTS

| | |
|-------------------------------|----|
| 11.1 Spare part list..... | 42 |
| 11.2 Oil for compressors..... | 42 |
| 11.3 Wiring diagrams | 42 |

12 - DISMANTLING, DEMOLITION AND SCRAPPING

| | |
|---------------------------|----|
| 12.1 Generalities | 43 |
| 12.2 RAEE Directive | 43 |

1 - Foreword

1.1 Introduction

Units, manufactured to state-of-the-art design and implementation standards, ensure top performance, reliability and fitness to any type of air-conditioning systems.

These units are designed for cooling water or glycoled water and are unfit for any purposes other than those specified in this manual.

This manual includes all the information required for a proper installation of the units, as well as the relevant operating and maintenance instructions.

It is therefore recommended to read this manual carefully before installation or any operation on the machine. The chiller installation and maintenance must be carried out by skilled personnel only (where possible, by one of Authorised Service Centers).

The manufacturer may not be held liable for any damage to people or property caused by improper installation, start-up and/or improper use of the unit and/or failure to implement the procedures and instructions included in this manual.

1.2 Warranty

These units are delivered complete, tested and ready for being operated. Any form of warranty will become null and void in the event that the appliance is modified without manufacturer's preliminary written authorisation.

This warranty shall apply providing that the installation instructions have been complied with (either issued by manufacturer, or deriving from the current practice), and the Form 1 ("Start-up") has been filled-in and mailed to manufacturer (attn. After-Sales Service).

In order for this warranty to be valid, the following conditions shall be met:

- The machine must be operated only by skilled personnel from Authorised After-Sales Service.
- Maintenance must be performed only by skilled personnel - from one of Authorised After-Sales Centers.
- Use only original spare parts.
- Carry out all the planned maintenance provided for by this manual in a timely and proper way.

Failure to comply with any of these conditions will automatically void the warranty.

1.3 Emergency stop / Normal stop

The emergency stop of the unit can be enabled using the master switch on the control panel (move down the lever).





For a normal stop, press the relevant push-buttons.

To restart the appliance, follow the procedure detailed in this manual.

1.4 An introduction to the manual

For safety reasons, it is imperative to follow the instructions given in this manual. In case of any damage caused by non-compliance with these instructions, the warranty will immediately become null and void.

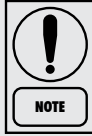
Conventions used throughout the manual:

| | |
|---|--|
|  | The DANGER sign recalls your attention to a certain procedure or practice which, if not followed, may result in serious damage to people and property. |
|  | The WARNING sign precedes those procedures that, if not followed, may result in serious damage to the appliance. |
|  | The NOTE contain important observations. |
|  | The USEFUL TIPS provide valuable information that optimises the efficiency of the appliance. |

This manual and its contents, as well as the documentation which accompanies the unit, are and remain the property of manufacturer, which reserves any and all rights thereon. This manual may not be copied, in whole or in part, without manufacturer's written authorization.

2 - Safety

2.1 Foreword

These units must be installed in conformity with the provisions of Machinery Directive 2006/42/EC, Pressure Equipment Directive 2014/68/EU, Electromagnetic Compatibility Directive 2014/30/EU, as well as with other regulations applicable in the country of installation. If these provisions are not complied with, the unit must not be operated.

| | |
|---|--|
|  | <p>The unit must be grounded, and no installation and/or maintenance operations may be carried out before deenergising the electrical panel of the unit.</p> |
|---|--|

Failure to respect the safety measures mentioned above may result in electrocution hazard and fire in the presence of any short-circuits.

| | |
|--|--|
|  | <p>Inside the heat exchangers, the compressors and the refrigeration lines, this unit contains liquid and gaseous refrigerant under pressure. The release of this refrigerant may be dangerous and cause injuries.</p> |
|--|--|

| | |
|---|---|
|  | <p>The units are not designed to be operated with natural refrigerants, such as hydrocarbons. Manufacturer may not be held liable for any problems deriving from the replacement of original refrigerant or the introduction of hydrocarbons.</p> |
|---|---|

Units are designed and manufactured according to the requirements of European Standard PED 2014/68/EU (pressure vessels).

- The used refrigerants are included in group II (non-hazardous fluids).
- The maximum working pressure values are mentioned on the unit's data plate.
- Suitable safety devices (pressure switches and safety valves) have been provided, to prevent any anomalous overpressure inside the plant.
- The vents of the safety valves are positioned and oriented in such a way as to reduce the risk of contact with the operator, in the event that the valve is operated. Anyway, the installer will convey the discharge of the valves far from the unit.
- Dedicated guards (removable panels with tools) and danger signs indicate the presence of hot pipes or components (high surface temperature).

| | |
|---|---|
|  | <p>The guards of the fans (only for units provided with air heat exchangers) must be always mounted and must never be removed before de-energising the appliance.</p> |
|---|---|

| | |
|---|---|
|  | <p>It is the User's responsibility to ensure that the unit is fit for the conditions of intended use and that both installation and maintenance are carried out by experienced personnel, capable of respecting all the recommendations provided by this manual.</p> <p>It is important that the unit is adequately supported, as detailed in this manual. Non-compliance with these recommendations may create hazardous situations for the personnel.</p> |
|---|---|

| | |
|---|---|
|  | <p>The unit must rest on a base which meets the characteristics specified in this manual; a base with inadequate characteristics is likely to become a source of serious injury to the personnel.</p> |
|---|---|

| | |
|---|--|
|  | <p>The unit has not been design to withstand loads and/or stress that may be transmitted by adjacent units, piping and/or structures.</p> <p>Each external load or stress transmitted to the unit may break or cause breakdowns in the unit's structure, as well as serious dangers to people. In these cases, any form of warranty will automatically become null and void.</p> |
|---|--|

| | |
|---|--|
|  | <p>The packaging material must not be disposed of in the surrounding environment or burnt.</p> |
|---|--|

2 - Safety

2.2 Definitions

OWNER: means the legal representative of the company, body or individual who owns the plant where unit has been installed; he/she has the responsibility of making sure that all the safety regulations specified in this manual are complied with, along with the national laws in force.

INSTALLER: means the legal representative of the company who has been given by the owner the job of positioning and performing the hydraulic, electric and other connections of unit to the plant: he/she is responsible for handling and properly installing the appliance, as specified in this manual and according to the national regulations in force.

OPERATOR: means a person authorised by the owner to do on unit all the regulation and control operations expressly described in this manual, that must be strictly complied with, without exceeding the scope of the tasks entrusted to him.

ENGINEER: means a person authorised directly by manufacturer or, in all EC countries, excluding Italy, under his full responsibility, by the distributor of product, to perform any routine and extraordinary maintenance operations, as well as any regulation, control, servicing operations and the replacement of pieces, as may be necessary during the life of the unit.

2.3 Access to the unit

The unit must be placed in an area which can be accessed also by OPERATORS and ENGINEERS; otherwise the unit must be surrounded by a fence at not less than 2 meters from the external surface of the machine.

OPERATORS and ENGINEERS must enter the fenced area only after wearing suitable clothing (safety shoes, gloves, helmet etc.). The INSTALLER personnel or any other visitor must always be accompanied by an OPERATOR.

For no reason shall any unauthorised personnel be left alone in contact with the unit.

2.4 General precautions

The OPERATOR must simply use the controls of the unit; he must not open any panel, other than the one providing access to the control module.

The INSTALLER must simply work on the connections between plant and machine; he must not open any panels of the machine and he must not enable any control.

When you approach or work on the unit, follow the precautions listed below:

- do not wear loose clothing or jewellery or any other accessory that may be caught in moving parts
- wear suitable personal protective equipment (gloves, goggles etc.) when you have to work in the presence of free flames (welding operations) or with compressed air
- if the unit is placed in a closed room, wear ear protection devices
- cut off connecting pipes, drain them in order to balance the pressure to the atmospheric value before disconnecting them,

disassemble connections, filters, joints or other line items

- do not use your hands to check for any pressure drops
- use tools in a good state of repair; be sure to have understood the instructions before using them
- be sure to have removed all tools, electrical cables and any other objects before closing and starting the unit again

2.5 Precautions against residual risks

Prevention of residual risks caused by the control system

- be sure to have perfectly understood the operating instructions before carrying out any operation on the control panel
- when you have to work on the control panel, keep always the operating instructions within reach
- start the unit only after you have checked its perfect connection to the plant
- promptly inform the ENGINEER about any alarm involving the unit
- do not reset manual restoration alarms unless you have identified and removed their cause

Prevention of residual mechanical risks

- install the unit according to the instructions provided in this manual
- carry out all the periodical maintenance operations prescribed by this manual
- wear a protective helmet before accessing the interior of the unit
- before opening any panelling of the machine, make sure that it is secured to it by hinges
- do not touch air condensation coils without wearing protective gloves
- do not remove the guards from moving elements while the unit is running
- check the correct position of the moving elements' guards before restarting the unit

Prevention of residual electrical risks

- connect the unit to the mains according to the instructions provided in this manual
- periodically carry out all the maintenance operations specified by this manual
- disconnect the unit from the mains by the external disconnecting switch before opening the electrical board
- check the proper grounding of the unit before start-up
- check all the electrical connections, the connecting cables, and in particular the insulation; replace worn or damaged cables

2 - Safety

- periodically check the board's internal wiring
- do not use cables having an inadequate section or flying connections, even for limited periods of time or in an emergency

Prevention of other residual risks

- make sure that the connections to the unit conform to the instructions provided in this manual and on the unit's panelling
- if you have to disassemble a piece, make sure that it has been properly mounted again before restarting the unit
- do not touch the delivery pipes from the compressor, the compressor and any other piping or component inside the machine before wearing protective gloves
- keep a fire extinguisher for electrical appliances near the machine
- on the units installed indoor, connect the safety valve of the refrigeration circuit to a piping network that can channel any overflowing refrigerant outside
- remove and leak of fluid inside and outside the unit
- collect the waste liquids and dry any oil spillage
- periodically clean the compressor compartment, to remove any fouling
- do not store flammable liquids near the unit
- do not disperse the refrigerant and the lubricating oil into the environment
- weld only empty pipes; do not approach flames or other sources of heat to refrigerant pipes
- do not bend/hit pipes containing fluids under pressure

2.6 Precautions during maintenance operations

Maintenance operations can be carried out by authorised technicians only.

Before performing any maintenance operations:

- disconnect the unit from the mains with the external disconnecting switch

- place a warning sign "do not turn on - maintenance in progress" on the external disconnecting switch
- make sure that on-off remote controls are inhibited
- wear suitable personal protective equipment (helmet, safety gloves, goggles and shoes etc.)

To carry out any measurements or checks which require the activation of the machine:





- work with the electrical board open only for the necessary time
- close the electrical board as soon as the measurement or check has been completed
- for outdoor units, do not carry out any operations in the presence of dangerous climatic conditions (rain, snow, mist etc.)

The following precautions must be always adopted:

- do not scatter the fluids of the refrigeration circuit in the surrounding environment
- when replacing an eprom or electronic cards, use always suitable devices (extractor, antistatic bracelet, etc.)
- to replace a compressor, the evaporator, the condensing coils or any other weighty element, make sure that the lifting equipment is consistent with the weight to be lifted
- in air units with independent compressor compartment, do not access the fan compartment unless you have disconnected the machine by the disconnecting switch on the board and you have placed a warning sign "do not turn on - maintenance in progress"
- contact manufacturer for any modifications to the refrigeration, hydraulic or wiring diagram of the unit, as well as to its control logics
- contact manufacturer if it is necessary to perform very difficult disassembly and assembly operations
- use only original spare parts purchased directly from manufacturer or the official retailers of the companies on the recommended spare parts list
- contact manufacturer if it is necessary to handle the unit one year after its positioning on site or if you wish to dismantle it.

2 - Safety (continued)

2.7 Safety labels

| Identification of the unit Outside, on the left -hand front column | |
|---|---|
| CODICE PRODOTTO NEUTRO PRODUCT CODE | |
|   | |
| MODELLO MODEL | |
|  0425 | |
| MO.NO SERIAL NO. | |
|  | |
| ANNO DI COSTRUZIONE Manuf. Year | |
| REFR. <input type="checkbox"/> GWP | CIRCUIT CHARGE (kg) <input type="checkbox"/> 1 <input type="checkbox"/> 2 <input type="checkbox"/> 3 <input type="checkbox"/> 4 |
| PS (LATO ALTA / LATO BASSA) PS (HIGH / LOW SIDE) bar | |
| TS (ALTA / BASSA) TS (HIGH / LOW) °C | |
| ALIM. POTENZA MAIN SUPPLY V / PH / Hz | |
| CORRENTE DI SPUNTO LRA (max) A | |
| CORRENTE A PIENO CARICO FLA (max) A | |
| POTENZA ASSORBITA POWER INPUT (max) Kw | |
| PRESS. MAX ESERCIZIO ACQUA MAX WATER OPERATING PRESSURE bar | |
| MASSA MASS Kg | |
| SYSTEMAIR S.r.l. Via XXV Aprile 29 20825 BARLASSINA MB ITALIA MADE IN ITALY COD.NO. P35952 | |
| MODELLO: MODEL | |
| MATRICOLA: SERIAL NO. | ANNO DI COSTRUZIONE Manuf. Year |
| CODICE: PRODUCT CODE | |
| MODELLO: MODEL | |
| MATRICOLA: SERIAL NO. | ANNO DI COSTRUZIONE Manuf. Year |
| CODICE: PRODUCT CODE | |
| MODELLO: MODEL | |
| MATRICOLA: SERIAL NO. | ANNO DI COSTRUZIONE Manuf. Year |
| CODICE: PRODUCT CODE | |
| Pump operation - Outside, on the left-hand front column | |
| <p>LAS BOMBAS MONTADAS EN ESTA UNIDAD NO PUEDEN TRABAJAR SIN AGUA. DIE PUMPEN DIESES GERÄTES DÜRFEN NICHT OHNE WASSER BE TREIBEN WERDEN THE PUMPS ON BOARD OF THIS UNIT CAN NOT WORK WITHOUT WATER. LES POMPES A BORD DE CETTE UNITE NE PEUVENT PAS FONCTIONNER SANS EAU. LE POMPE A BORDO DI QUESTA UNITÀ NON POSSONO FUNZIONARE SENZA ACQUA</p> | |

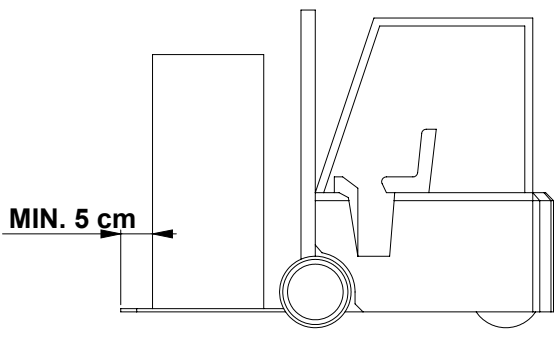
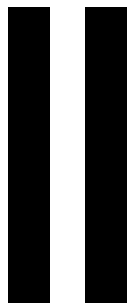
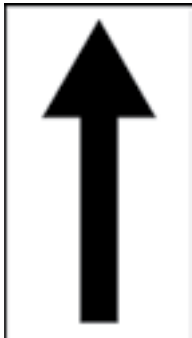
| Instruction for the movimentation - Outside the packaging | |
|--|---|
|  | |
| Sequence phase control on the electrical board | |
| <p>ATTENZIONE QUESTO COMPRESSORE RICHIEDE UN CORRETTO SENSO DI ROTAZIONE RISPETTARE LA CORRETTA SEQUENZA DELLE FASI CAUTION THIS COMPRESSOR REQUIRES PROPER DIRECTION OF ROTATION CHECK PROPER ELECTRICAL PHASING ACHTUNG KOMPRESSOREN BENÖTIGEN KORREKTES DREHFELD. ELEKTRISCHE ANSCHLÜSSE AUF DREHFELD ÜBERPRÜFEN ATTENTION CES COMPRESSEURS NECESSITENT UN BON SENSE DE ROTATION VERIFIER LE CABLAGE DES PHASES ATENCIÓN ESTOS COMPRESORES DEBEN FUNCIONAR EN EL SENTIDO DE ROTACIÓN CORRECTO COMPROBAR EL CABLEADO DE LAS FASES</p> | |
| Gravity centre - Base | Instruction for the lifting |
| <p>TENERE SU QUESTA LINEA GANCIO DI SOLLEVAMENTO</p>  <p>KEEP LIFT HOOK ON THIS LINE</p> |  |

2 - Safety (continued)

Electrical warning Adjacent to the master switch

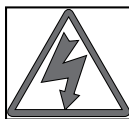

ATTENZIONE !
Prima di aprire togliere tensione

ATTENTION !
Enlever l'alimentation électrique avant d'ouvrir

ACHTUNG !
Vor öffnen des gehäuses hauptschalter ausschalten

CAUTION !
Disconnect electrical supply before opening

ATENCIÓN !
Cortar la corriente antes de abrir el aparato

Commissioning - Outside, on the left-hand front column

GB ATTENTION: IMPORTANT NOTICE FOR COMMISSIONING

Before the start-up, please read the following instructions carefully. The start-up must be carried out by a qualified person. The start-up must be carried out in accordance with the instructions in this manual. The start-up must be carried out in accordance with the instructions in this manual. The start-up must be carried out in accordance with the instructions in this manual.

I ATTENZIONE: ISTRUZIONI PER IL PRIMO AVVIAMENTO

Prima di avviare l'apparecchio, leggere attentamente le istruzioni in questo manuale. L'avviamento deve essere eseguito da personale qualificato. L'avviamento deve essere eseguito in conformità con le istruzioni in questo manuale. L'avviamento deve essere eseguito in conformità con le istruzioni in questo manuale.

D ACHTUNG: WICHTIGE HINWEISE BEI DER IN-STAELLUNG

Bevor Sie das Gerät in Betrieb nehmen, lesen Sie bitte die Bedienungsanleitung sorgfältig durch. Das Einschalten muss von qualifiziertem Personal durchgeführt werden. Das Einschalten muss in Übereinstimmung mit den Anweisungen in dieser Bedienungsanleitung erfolgen. Das Einschalten muss in Übereinstimmung mit den Anweisungen in dieser Bedienungsanleitung erfolgen.

F ATTENTION: INSTRUCTIONS POUR LA PREMIERE MISE EN MARCHE

Avant de mettre l'appareil en marche, lisez attentivement les instructions de ce manuel. Le démarrage doit être effectué par une personne qualifiée. Le démarrage doit être effectué conformément aux instructions de ce manuel. Le démarrage doit être effectué conformément aux instructions de ce manuel.

E ATTENZIONE: ISTRUCCIONES PARA LA PRIMERA PUESTA EN MARCHA

Antes de poner el aparato en marcha, lea atentamente las instrucciones de este manual. El arranque debe ser realizado por personal cualificado. El arranque debe realizarse de acuerdo con las instrucciones de este manual. El arranque debe realizarse de acuerdo con las instrucciones de este manual.

Final Test Certificate - Inside the external door

| QUALITY CHECK PROOF | | | |
|---------------------|--|---------------------|---------------------|
| MODEL/TYPE | SERIAL NUMBER/PRODUCTION LOT | P. NUMBER/CODE | MANUFACTURED YEAR |
| MODELLO/TIPO | N° DI SERIE/LOTTO DI PRODUZIONE | CODICE | ANNO DI COSTRUZIONE |
| | | | |
| NUMBER CHECK | DESCRIPTION OF INSPECTION | INSPECTOR REFERENCE | |
| NUMERO CONTROLLI | DESCRIZIONE DEI TEST DI CONTROLLO | TIMBRO OPERATORE | |
| 01 | PRELIMINARY PROOF: PRESSURE TEST AND LEAK TEST WITH HELIUM AND NITROGEN AT MINIMUM 10 BAR (REFRIGERANT SIDE) IN COMPLIANCE WITH TEST SPECIFICATION - MARK WITH PENS PROVA PRELIMINARE DI PRESSIONE E TENUTA CIRCUITO CON ELIO (AZOTO AD ALMENO 10 BAR (LATO REFRIGERANTE), IN ACCORDO ALLA SPECIFICA DI COLLAUDO - SEGNARE CON PENNARELLO | | |
| 02 | LEAK TEST: FINAL TEST WITH HELIUM AND NITROGEN AT 2,5 BAR (WATER SIDE) - MARK WITH PENS EFFETTUARE UNA PROVA PRELIMINARE DI TENUTA CON ELIO E AZOTO A 2,5 BAR (LATO ACQUA) - SEGNARE CON PENNARELLO | | |
| 03 | WACUP TEST CARRIED OUT | | |
| 04 | REFRIGERANT CHARGE | | |
| 05 | ELECTRICAL SAFETY CHECK CONNECTION | | |
| 06 | SAFETY TEST: CONTINUITY, INSULATION, DIELECTRIC STRENGTH PROOF OF SAFETY, CONTINUITY, ISOLAMENTO, RESISTENZA | | |
| 07 | RUNNING TEST WITH SAFETY DEVICES | | |
| 08 | COLLAUDO FUNZIONALE COMPLETO CON INTERVENTO SICUREZZA E RILEV. | | |
| 09 | LEAK TEST ON REFRIGERANT CIRCUIT DURING RUNNING CONDITIONS - MARK WITH PENS VERIFICA TENUTA CIRCUITO REFRIGERANTE DURANTE IL FUNZIONAMENTO - SEGNARE CON PENNARELLO | | |
| 10 | FINAL LEAK TEST ON REFRIGERANT CIRCUIT AFTER RUNNING - MARK WITH PENS VERIFICA FINALE TENUTA CIRCUITO REFRIGERANTE DOPO IL COLLAUDO FUNZIONALE - SEGNARE CON PENNARELLO | | |
| 11 | CHECK ASSEMBLY PARTS | | |
| 12 | VERIFICA ASSEMBLAGGIO PARTI | | |
| 13 | CHECK INSTALLED ACCESSORIES OR SUPPLY LOOSE | | |
| 14 | CONTROLLO ACCESSORI MONTATI E/O FORNITI A BORDO UNITÀ | | |
| 15 | WIRING DIAGRAM, RULES, START-UP FORM | | |
| 16 | VERIFICA DOCUMENTI FORNITI CON L'UNITÀ | | |
| 17 | CHECK TEST SHEET AND CHECK LIST FILLED UP | | |
| 18 | CONTROLO COMPILAZIONE SCHEDE DI COLLAUDO E CHECK LIST | | |

Grounding connection on the electrical board, adjacent to the connection

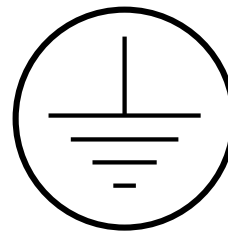

Read the instruction on the electrical board



Fitting identification - Adjacent to fittings

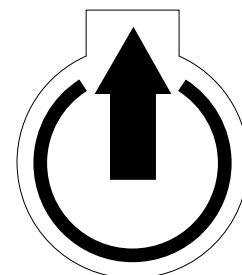
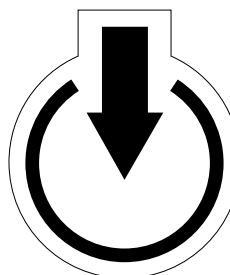

2 - Safety (continued)

Identification of refrigerant - Below identification of the unit

Contains fluorinated greenhouse gases covered by the Kyoto-Protocol.
 Contiene gas fluorurati ad effetto serra disciplinati dal Protocollo di Kyoto.
 Contient des gaz à effets de serre fluorés couverts par le Protocol de Kyoto.
 Enthält fluorierte Treibhausgase die vom Kyoto-Protokoll erfasst sind.
 Contiene gases fluorados de efecto invernadero cubiertas por el Protocolo de Kyoto.

Parameter configuration - Inside the electrical board

IMPORTANT !

NOTE: always check configuration parameters value setting after any reset or Control Board replacement.

NOTA: controllare sempre valori parametri configurazione dopo ogni reset o sostituzione scheda controllo.

ANMERKUNG: nach jeder Rücksetzung oder nach dem Ersatz der Steuerkarte immer die Konfigurationsparameterwerte prüfen

NOTE: contrôler toujours les valeurs des paramètres de configuration après chaque remise à zéro ou remplacement de la carte de contrôle

NOTA: controlar siempre los valores de los parámetros de configuración después de cada puesta a cero o sustitución de la tarjeta de control.

Pump drain - Outside, on the left-hand front column

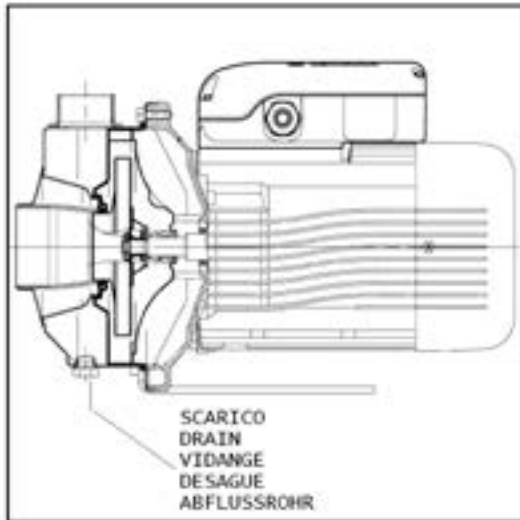

Circuit drain - Outside, on the left-hand front column



ATTENTION! Don't leave the unit with water inside hydraulic circuit during winter or when it is in stand by.
ATTENZIONE! Non lasciare l'unità con acqua nel circuito idraulico durante l'inverno o quando non è funzionante.
ATTENTION! Ne laissez pas l'unité avec de l'eau dans le circuit hydraulique pendant l'hiver ou quand elle ne travaille pas.
WARNING! Lassen Sie nicht das Wasser in die Schaltung während des Winters oder wenn es nicht funktioniert.
¡ATENCIÓN! No deje el agua en el circuito hidráulico durante el invierno o cuando no está trabajando.

Filter / flow switch - Outside, on the left-hand front column

! E' OBBLIGATORIO L'USO DI FILTRO E FLUSSOSTATO ACQUA
 THE USE OF FILTER AND FLOW SWITCH IS MANDATORY
 EL USO DEL FILTRO Y DEL INTERRUPTOR DE FLUJO ES OBLIGATORIO
 L'UTILISATION DU FILTRE ET DU FLUXOSTAT EST OBLIGATOIRE
 DER GEBRAUCH VON FILTER UND STRÖMUNGSWÄCHTER IST VORGESCHRIEBEN.

Fan Danger

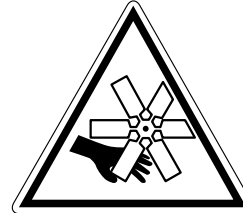

2 - Safety

2.8 Safety regulations

| REFRIGERANT DATA | SAFETY DATA: R410A |
|---|---|
| Toxicity | Low. |
| Contact with skin | <p>If sprayed, the refrigerant is likely to cause frost burns. If absorbed by the skin, the danger is very limited; it may cause a slight irritation, and the liquid is degreasing. Unfreeze the affected skin with water.</p> <p>Remove the contaminated clothes with great care - in the presence of frost burns, the clothes may stick to the skin. Wash with plenty of warm water the affected skin.</p> <p>In the presence of symptoms such as irritation or blisters, obtain medical attention.</p> |
| Contact with eyes | <p>Vapours do not cause harmful effects. The spraying of refrigerant may cause frost burns.</p> <p>Wash immediately with a proper solution or with tap water for at least 10 minutes, and then obtain medical attention.</p> |
| Ingestion | <p>Very unlikely - should something happen, it will cause frost burns.</p> <p>Do not induce vomiting. Only if the patient is conscious, wash out mouth with water and give some 250 ml of water to drink. Then, obtain medical attention.</p> |
| Inhalation | <p>R410A: remarkable concentrations in the air may have an anaesthetic effect, up to fainting.</p> <p>The exposure to considerable amounts may cause irregular heartbeat, up to the sudden death of the patient. Very high concentrations may result in the risk of asphyxia, due to the reduction in the oxygen percentage in the atmosphere. Remove the patient to fresh air and keep warm and at rest.</p> <p>If necessary, give oxygen. In case of breathing difficulties or arrest, proceed with artificial respiration.</p> <p>In case of cardiac arrest, proceed with cardiac massage. Then, obtain medical attention.</p> |
| Recommendations | <p>Semiotics or support therapy is recommended. Cardiac sensitisation has been observed that, in the presence of circulating catecholamines such as adrenalin, may cause cardiac arrhythmia and accordingly, in case of exposure to high concentrations, cardiac arrest.</p> |
| Prolonged exposure | <p>R410A: a study on the effects of exposure to 50,000 ppm during the whole life of rats has identified the development of benign testicle tumour.</p> <p>This situation should therefore be negligible for personnel exposed to concentrations equal to or lower than professional levels.</p> |
| Professional levels | R410A: Recommended threshold: 1000 ppm v/v - 8 hours TWA. |
| Stability | R410A: Not specified. |
| Conditions to avoid | Do not use in the presence of flames, burning surfaces and excess humidity. |
| Hazardous reactions | <p>May react with sodium, potassium, barium and other alkaline metals.</p> <p>Incompatible substances: magnesium and alloys with magnesium concentrations > 2%.</p> |
| Hazardous decomposition products | R410A: Halogen acids produced by thermal decomposition and hydrolysis. |

2 - Safety

2.8 Safety regulations (continued)

| REFRIGERANT DATA | SAFETY DATA: R410A |
|---|---|
| General precautions | Do not inhale concentrated vapours. Their concentration in the atmosphere should not exceed the minimum preset values and should be maintained below the professional threshold. Being more weighty than the air, the vapour concentrates on the bottom, in narrow areas. Therefore, the exhaust system must work at low level. |
| Respiratory system protection | If you are in doubt about the concentration in the atmosphere, it is recommended to wear a respirator approved by an accident-prevention Authority, of the independent or oxygen type. |
| Storage | Cylinders must be stored in a dry and fresh place, free from any fire hazard, far from direct sunlight or other sources of heat, radiators etc. Keep a temperature below 50 °C. |
| Protective clothing | Wear overalls, protective gloves and goggles or a mask. |
| Accidental release measures | It is important to wear protective clothing and a respirator. Stop the source of the leak, if you can do this without danger. Negligible leaks can be left evaporating under the sun, providing that the room is well ventilated. Considerable leaks: ventilate the room. Reduce the leak with sand, earth or other absorbing substances. Make sure that the liquid does not channelled into gutters, sewers or pits where the vapours are likely to create a stuffy atmosphere. |
| Disposal | The best method is recovery and recycling. If this method is not practicable, dispose according to an approved procedure, that shall ensure the absorption and neutralization of acids and toxic agents. |
| Fire fighting information | R410A: Not flammable in the atmosphere. |
| Cylinders | The cylinders, if exposed to fire, shall be cooled by water jets; otherwise, if heated, they may explode. |
| Protective fire fighting equipment | In case of fire, wear an independent respirator and protective clothing. |

2 - Safety

2.8 Safety regulations (continued)

| LUBRICANT OIL DATA | SAFETY DATA: POLYESTER OIL (POE) |
|---|---|
| Classification | Not harmful. |
| Contact with skin | May cause slight irritation. Does not require first aid measures. It is recommended to follow usual personal hygiene measures, including washing the exposed skin with soap and water several times a day. It is also recommended to wash your overalls at least once a week. |
| Contact with eyes | Wash thoroughly with a suitable solution or tap water. |
| Ingestion | Seek medical advice immediately. |
| Inhalation | Seek medical advice immediately. |
| Conditions to avoid | Strong oxidising substances, caustic or acid solutions, excess heat. May corrode some types of paint or rubber. |
| Protection of the respiratory system | Use in well ventilated rooms. |
| Protective clothing | Always wear protective goggles or a mask. Wearing protective gloves is not mandatory, but is recommended in case of prolonged exposure to refrigerant oil. |
| Accidental release measures | It is important to wear protective clothing and, especially, goggles. Stop the source of the leak. Reduce the leak with absorbing substances (sand, sawdust or any other absorbing material available on the market). |
| Disposal | The refrigerant oil and its waste will be disposed of in an approved incinerator, in conformity with the provisions and the local regulations applicable to oil waste. |
| Fire fighting information | In the presence of hot liquid or flames, use dry powder, carbon dioxide or foam. If the leak is not burning, use a water jet to remove any vapours and to protect the personnel responsible for stopping the leak. |
| Cylinders | The cylinders exposed to a fire will be cooled with water jets in case of fire. |
| Fire fighting protective equipment | In case of fire, wear an independent respirator. |

3 - Transport, Handling and Storage

Units are supplied fully assembled and tested (except for accessories supplied loose in the units – absorbers, filter, etc.). They are ready to be installed and started on the field.

R410A units are only charged with liquid refrigerant and with oil in the quantity required for operation.



The low pressure side of the refrigerating circuit on R410A units shall be charged by means of the service valve arranged on the thermal expansion valve before the device is operated.

3.1 Inspection

The unit shall be immediately inspected upon receipt to find out any damage since it has been delivered ex works and transported at the customer's risk. It is also necessary to make sure that all the parcels specified on the delivery note have been delivered.

Any damage you may find out shall be immediately reported in writing to the carrier. Even if the damage is only on the surface, please notify our local representative too.

The manufacturer disclaims all responsibility for the shipment even if it has provided for its organisation.

3.2 Handling

Units are designed to be lifted from above, by means of cables and eyebolts. A spacer shall be arranged between the cables in order to prevent them from damaging the unit (see the figure aside).

Before handling the devices, make sure the site you have chosen for the installation can withstand its weight and support its mechanical impact.

Avoid touching sharp parts (such as the fins of batteries, for example) while handling the unit.



The unit shall never be placed on rollers.

Act as follows to lift and handle the unit:

- Insert and secure the eyebolts into the frame holes which have been marked on purpose.
- Connect the cables to the eyebolts.
- Insert the spacer between the cables.
- Provide for hooking at the centre of gravity of the device.
- Cables shall have such a length that the angle they form with the horizon when under tension is not less than 45°.

Space requirements request to handling

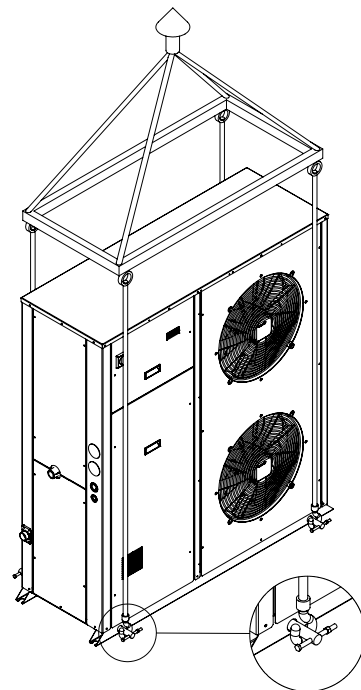
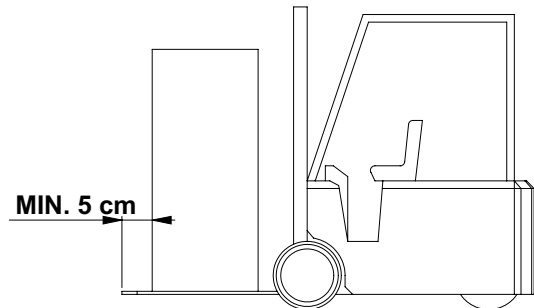

Holes \varnothing 30 mm



While lifting and handling the unit, pay attention. Otherwise, you might damage the finned block of the coils arranged on both sides of the unit. The sides of the unit shall be protected by cardboard or plywood sheets.

3 - Transport, Handling and Storage



Until the unit is ready for operation, do not remove the plastic envelope and the coil protections which are intended to prevent dirt, dust and any foreign matter from penetrating into the unit through the inlets of fans or from damaging the external surfaces.

3.3 Anchoring

It is not essential to secure the unit to the foundations, unless in areas where there is a serious risk of earth-quake, or if the appliance is installed on the top of a steel frame.

3.4 Storage

If the unit is to be stored before the installation for some time, take at least the following precautions to prevent damage, corrosion and/or deterioration:

- Make sure all openings, such as for example water connections, are well plugged and sealed.

- Never store the units in a room where temperature is above 50 °C (R410A units) or where the units are directly exposed to the sunlight.
- Minimum storage temperature is -25 °C.
- It is recommended to leave the finned coils covered to protect them against any risk of corrosion, especially if building works are still in progress.
- Store the units in areas where minimum activity is likely to take place in order to avoid any risk of accidental damage.
- Never use steam to clean the unit.
- Remove all the keys required to have access to the control panel and give them to the person in charge of the field.

It is also recommended to provide for visual inspections at regular intervals.

4 - Installation

4.1 Installation Site



Before installing the unit, make sure that the building structure and/or the supporting surface can withstand the weight of the device. The weights of the units are detailed by Chapter 9 of this manual.

These units have been designed to be installed on the floor, in the open air. As a standard, they are equipped with rubber vibration-damping supports which shall be arranged in the middle, beneath the supporting plates.

When the unit is to be installed on the ground, provide for a concrete bedplate which shall assure a uniform distribution of the weights. No special subbase is generally required.

When selecting the installation site, never forget to consider as follows:

- The longitudinal axis of the unit shall be parallel to the direction of the prevailing winds so as to assure a uniform air distribution on finned exchangers.
- The unit shall never be installed in the proximity of chimneys for the discharge of boiler flue gases.
- The unit shall never be installed downwind of sources of grease contaminated air, such as for example the outlets of large-kitchen extractors. Otherwise, grease might build up on the fins of refrigerant / air exchangers or condensers, act as a fixing agent for any sort of atmospheric impurity and rapidly cause the exchangers to clog.
- The unit shall never be installed in areas exposed to heavy snowfalls.
- The unit shall never be installed in areas exposed to flooding or beneath drip stones, etc.
- The unit shall never be installed in narrow inner court yards or in any other restricted space where the noise may be reflected by the walls or where the air expelled by the fans may short-circuit on the refrigerant/air heat exchangers or condensers.
- The installation site shall be characterised by the presence of the space required for air circulation and for the performance of maintenance operations (see chapter 9 for further details).

4.2 External Water Circuit



The external water circuit shall guarantee a constant water flow rate through the circulating refrigerant/water heat exchanger (evaporator) under steady operating conditions and in case of a load variation.

The circuit shall be composed by the following elements:

- A circulation pump which can ensure the necessary flow rate and head.
- The total content of the primary water circuit shall never be lower than 4 lt/kW in terms of refrigerating capacity. If the total water volume in the primary circuit should be unable to reach such a value, an additional heat-insulated storage tank should be installed. This tank is intended to avoid any repetitive start of the compressor.
- A membrane expansion tank complete with a safety valve and a drain which shall be visible.



The expansion tank shall be dimensioned in such a way that it can absorb a 2% expansion of the total volume of the water in the plant (exchanger, pipelines, uses and storage tank, if available). The expansion tank shall never be insulated when the circulating fluid is not flowing through it.

A differential pressure switch is mounted as a standard. It will stop the unit whenever it senses a load loss through the heat exchanger which may result in a flow rate problem.

In addition:

- Install on/off valves (accessory) on the lines at the inlet and outlet of the manifolds of the exchangers (evaporator).
- Arrange a by-pass complete with an on/off valve between the manifolds of the heat exchangers.
- Arrange air vent valves at the high points of the water lines.
- Arrange drain points complete with plugs, clocks, etc. in the proximity of the low points of the water lines.
- Insulate the water lines to prevent the heat from blowing back into the unit.

4 - Installation

External water circuit SYSCROLL 20-35 Air CO - R410A

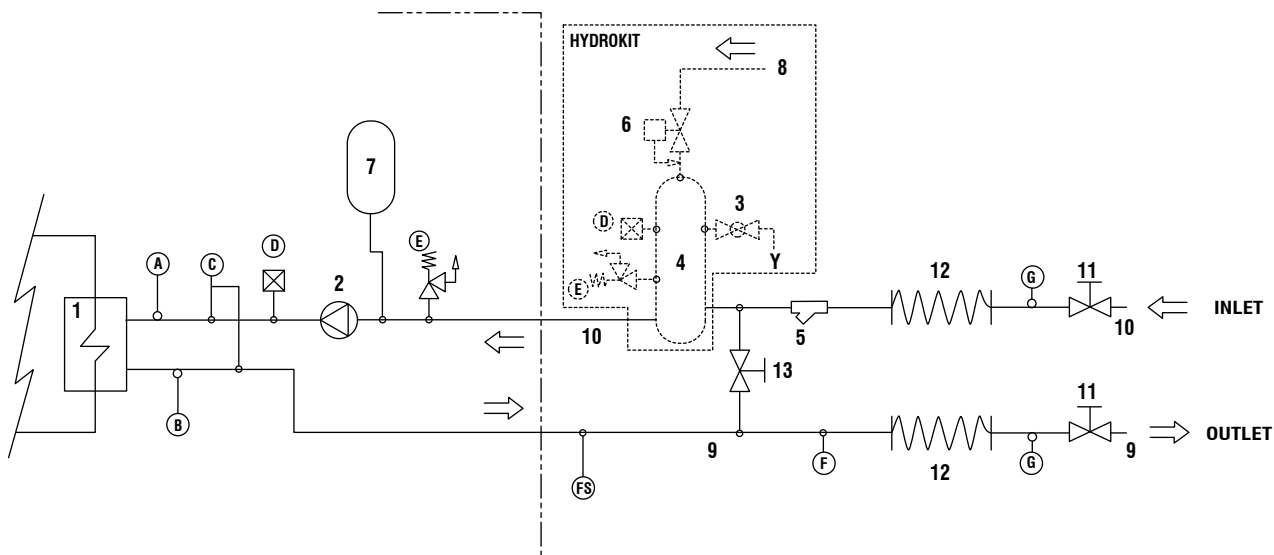

COMPONENTS

| | |
|-----------|--------------------------------|
| 1 | Plate heat exchanger |
| 2 | Pump |
| 3 | Draining valve |
| 4 | Water buffer tank |
| 5 | Water filter |
| 6 | Automatic water charging valve |
| 7 | Pressure expansion tank |
| 8 | Water charging line |
| 9 | Water outlet |
| 10 | Water inlet |
| 11 | Globe valve |
| 12 | Flexible pipes |
| 13 | By-pass valve |

SAFETY/CONTROL DEVICES

| | |
|-----------|---|
| A | Inlet water temperature sensor |
| B | Outlet water temperature sensor |
| C | Water differential pressure switch (105 mbar) |
| D | Vent valve |
| E | Water safety valve (3 bar) |
| F | Manometer |
| FS | Flow switch |
| G | Thermometer |
| ---- | Unit side |
| Y | Water drain |

4 - Installation



Before filling the installation, remove any impurity, such as sand, crushed stones and welding scales, coating drops and any other material which might damage the evaporator.

It is advisable to flush with disposable water bypassing the exchanger to avoid clogging.



The water used to fill the circuit shall be treated in such a way that the pH will have the correct value.

When two or several units are connected in parallel, to balance the load losses of the various circuits, it is recommended to execute a "reverse return" connection (see the diagram below).

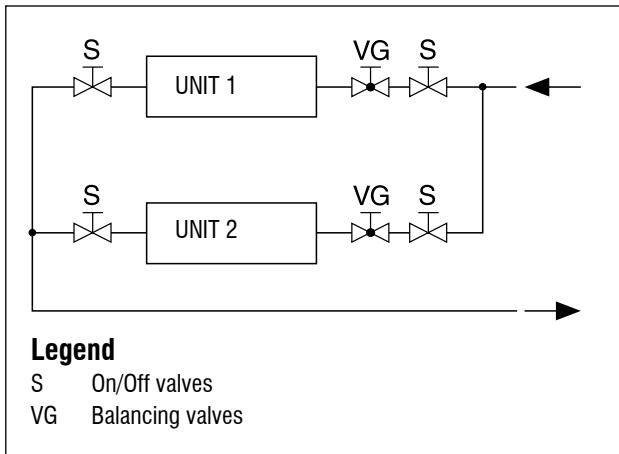

4.3 Water connections

The flow switch and the filter water, although not included in the supply, must always be fitted such as plant components. Their installation is mandatory for warranty.



The attachments at the water inlet and outlet shall be connected in compliance with the instructions which can be found on the labels in the proximity of the attachments.

Connect the water lines of the plants with the attachments of the unit whose diameters and positions are shown in Chapter 9.

4.4 Water buffer tank

The accumulation tank is complete with all the hydraulic and electrical components required for the correct operation of the system.

These systems are carefully assembled and tested at works. They are ready for operation after having correctly realised all electrical and hydraulic connections.

4.4.1 Features

The kit will include an Antifreeze Electric Heater, a drain valve, an automatic filling unit and an automatic air vent.

No pump is arranged on the kit since it is mounted on the unit.

The tank is completely insulated with 30 Kg/m³ closed cell polyethylene in a silver colour and enclosed by a bearing structure made of passivated and painted plates. The box is equipped with bulkheads which can be easily opened for internal inspection.

The kit is installed beneath the chiller. It is an integral part of the unit without changing the support area.

| RECOMMENDED WATER COMPOSITION | | |
|---|-----------|-------|
| PH | 7,5 - 9 | |
| Electrical conductivity | 10 - 500 | μS/cm |
| Total hardness | 4,5 - 8,5 | dH |
| Temperature | < 60 | [°C] |
| Alkalinity (HCO ₃ ⁻) | 70-300 | ppm |
| Alkalinity / Sulphates (HCO ₃ ⁻ / SO ₄ ²⁻) | > 1 | ppm |
| Sulphates (SO ₄ ²⁻) | < 70 | ppm |
| Chlorides (Cl.) | < 50 | ppm |
| Free Chlorine | < 0,5 | ppm |
| Phosphates (PO ₄ ³⁻) | < 2 | ppm |
| Ammonia (NH ₃) | < 0,5 | ppm |
| Ammonium Ion (NH ₄ ⁺) | < 2 | ppm |
| Manganese Ion (Mn ²⁺) | < 0,05 | ppm |
| Free Carbon Dioxide (CO ₂) | < 5 | ppm |
| Hydrogen Sulfide (H ₂ S) | < 0,05 | ppm |
| Oxygen Content | < 0,1 | ppm |
| Nitrates (NO ₃ ⁻) | < 100 | ppm |
| Manganese (Mn) | < 0,1 | ppm |
| Iron (Fe) | < 0,2 | ppm |
| Aluminium (Al) | < 0,2 | ppm |

Caution

If the water circuit is to be drained for a time exceeding one month, the circuit must be fully charged with nitrogen to prevent any risk of corrosion by differential venting

4 - Installation

4.4.2 Supplied Material

The kits will be supplied with pipelines ready for installation. An antifreeze resistance with wiring, an automatic water filling valve, a 3 bar safety valve, a drain valve and a vent valve have already been assembled.

Hydrokit is shipped with a film to protect it from atmospheric agents. Packaging has been designed in order to stack it up.

4.4.3 Antifreeze Electric Heater

The antifreeze resistance of the tank (TEH) shall be wired with the panel as it is shown by the diagram attached to the unit.

4.4.4 Water Filter

The kit will use the water filter of the unit.

CAUTIONS

The unit + tank system shall be equipped with a filter. Use the filter + union as it is shown by Figure 1.

Figure 1

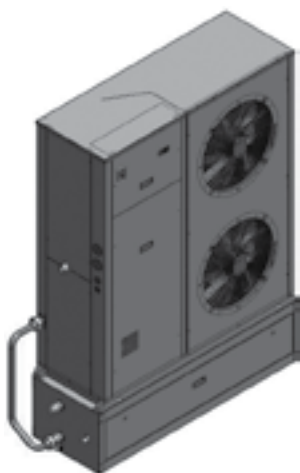

4.4.5 Installation Procedure

For the size 20-35 the hydrokit shall be arranged beneath the unit. It will not change its overall dimensions (Figure 1).

Arrange the rubber shock absorbers beneath the kit before providing for its connection.

Provide for the hydraulic and electrical connections. Doing that, observe the diameters shown by the quoted drawings.

The wiring for the standard antifreeze resistance is arranged as it is shown by . The resistance is connected with the main terminal box.

See the wiring diagram attached to the unit for the correct execution of the electrical connections.

Install the water filter as it is shown by Figure 1.

4.5 Power supply



Before carrying out any operations on the electrical system, make sure that the unit is deenergized.



It is important that the appliance is grounded.



The company in charge of the installation shall conform to the standards applicable to outdoor electrical connections.

The manufacturer may not be held liable for any damage and/or injury caused by failure to comply with these precautions.

The unit conforms to EN 60204-1.

The following connections shall be provided:

- A 3-phase and grounding connection for the power supply circuit.
- The electrical distribution system shall meet the power absorbed by the appliance.
- The disconnecting and magnetothermal switches must be sized to control the starting current of the unit.
- The power supply lines and the insulation devices must be designed in such a way that every line independent.
- It is recommended to install differential switches, to prevent any damage caused by phase drops.
- The fans and compressors are supplied through contactors controlled from the control panel.
- Each motor is provided with an internal safety thermal device and external fuses.
- The power supply cables must be inserted into dedicated openings on the front of the unit, and they will enter the electrical board through holes drilled on the bottom of the board.

4 - Installation

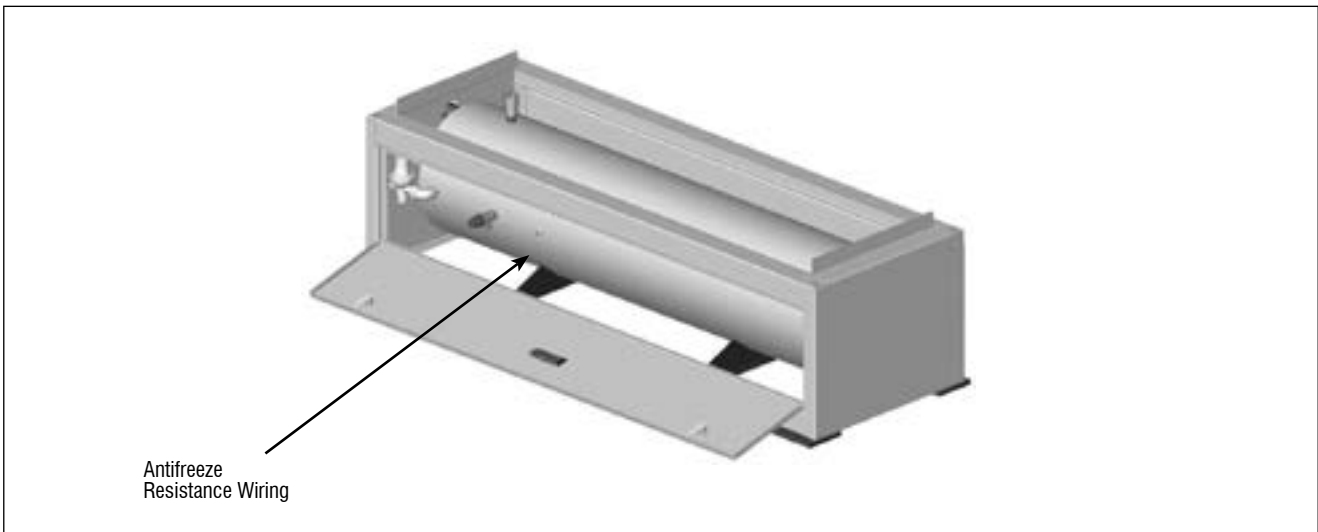

4.6 Electrical connections

The unit must be installed on site according to the usual procedures and standards applicable in the place of installation. The unit must not be operated if its installation has not been carried out according to the instructions provided in this manual.

The power supply lines must consist of insulated copper conductors, dimensioned for the maximum absorbed current.

Connection to terminals must be performed according to the diagram of connections (User's Terminal Box) provided in this manual and according to the wiring diagram which accompanies the unit.



Before connecting the power supply lines, check that the available voltage value does not exceed the range specified in the Electric Data (Chapter 9).

For 3-phase systems, check also that the unbalance between the phases does not exceed 2%. To perform this check, measure the differences between the voltage of each phase couple and their mean value during operation. The maximum % value of these differences (unbalance) must not exceed 2% of the mean voltage.

If the unbalance is unacceptable, contact the Energy Distributor to solve this problem.



Supplying the unit through a line whose unbalance exceeds the permissible value will automatically void the warranty.

4 - Installation

SYSCROLL Air CO Version - Electrical Connections

QG - Y1

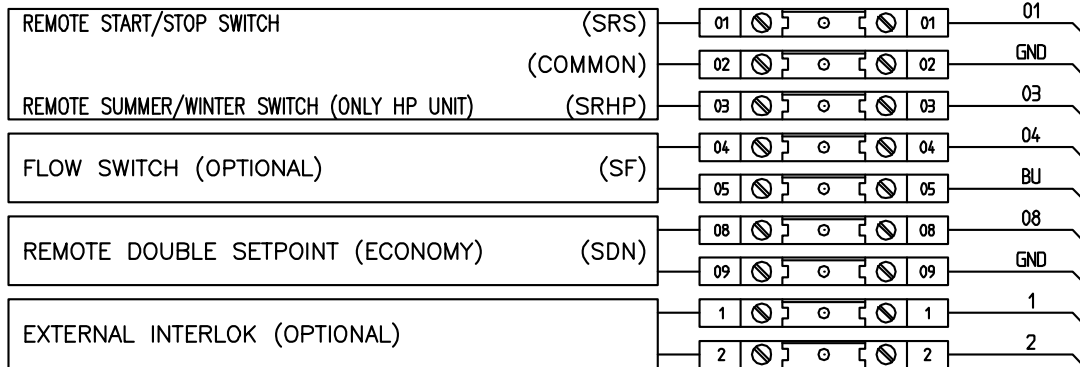

QG - Y2

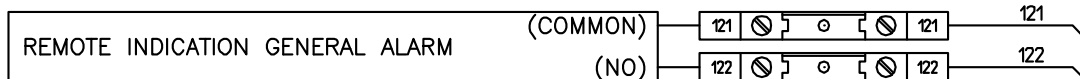

QG - Y3

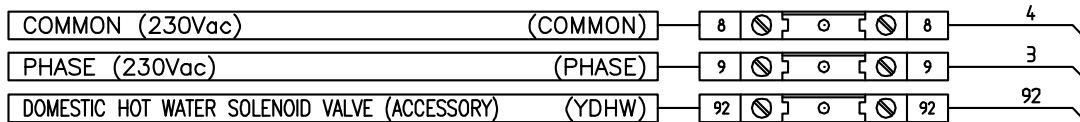

QG - Y4

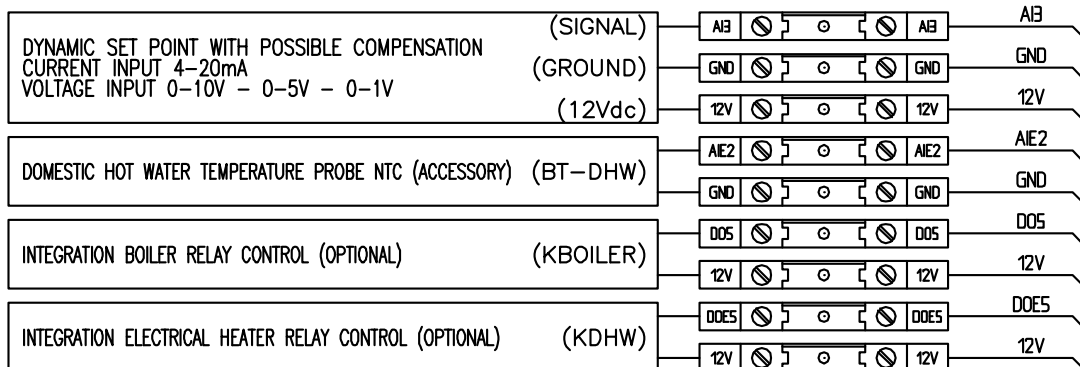

4 - Installation

SYSCROLL Air RE Version - Electrical Connections

QG - Y1

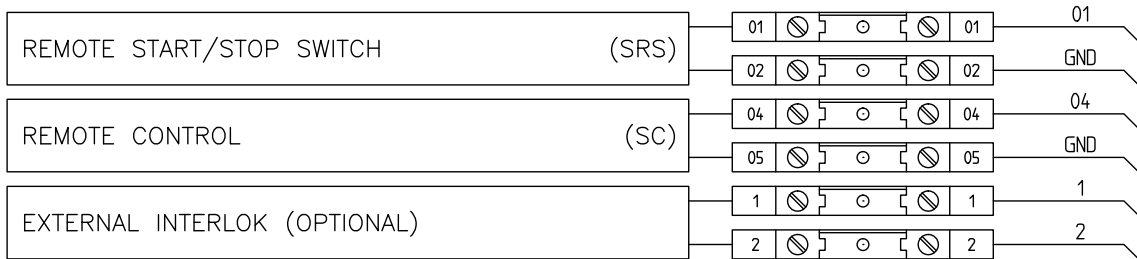

QG - Y2

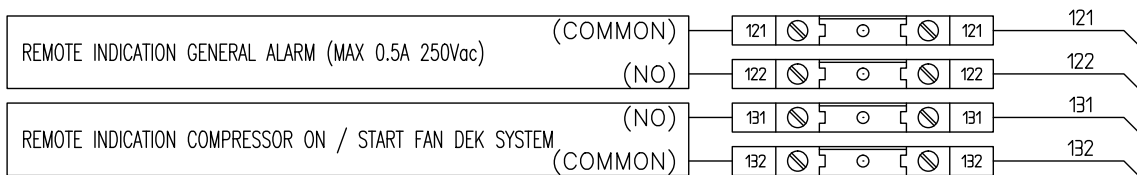

QG - Y3

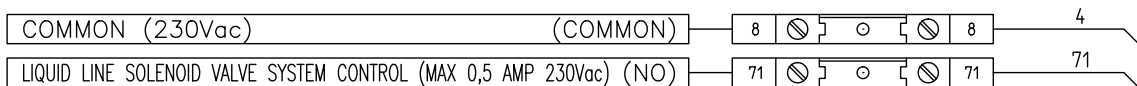

5 - Start-up



The unit must be started for the first time by personnel suitably trained by one of Authorised Service Centre. Failure to meet this requirement will immediately void the warranty.



The operations carried out by authorised personnel are limited to the start-up of the unit, and do not include any other operation on the plant, such as, for example, electrical and hydraulic connections etc. All the other operations before start-up, including oil pre-heating for at least 12 hours, must be performed by the Installer.

5.1 Preliminary check

The checks listed below shall be performed before starting the unit and before the arrival of the personnel authorised.

- Check the section of power supply and grounding cables; make sure that terminals are tightened and check the correct operation of contactors, with the main switch open.
- Check that any voltage and phase variation in the power supply does not exceed the prefixed thresholds.
- Connect the contacts of the flow switch and of an external interlock, to terminals 1-2 and 3-4 (Y1 user terminal), respectively.
- Check that the components of the external water circuit (pump, user equipment, filters, power supply tank and reservoir, if any) have been installed properly, and according to the manufacturer's instructions.
- Check the filling of the hydraulic circuits, and make sure that the fluid circulation is correct, without any trace of leaks and air bubbles. If you use ethylene glycol as antifreeze, check that its percentage is correct (do not exceed 35% glycol percentage).
- Check that the direction of rotation of the pumps is correct, and that fluids have been circulating for at least 12 hours for both pumps. Then, clean the filters on the suction side of the pumps.
- Adjust the liquid distribution network in such a way that the flow rate is within the specified range.
- Check that the water quality is up to the specifications.
- Check that oil heaters, if any, have been turned on at least 12 hours before.

5.2 Start-up

Start-up sequence:

- Turn on the Main switch (at least 12 hours before).
- Check that the oil in the compressor has reached the requested temperature (the minimum temperature outside the pan must be approx. 40°C) and that the auxiliary control circuit is energised.
- Check the operation of all the external equipment, and make sure

that the control devices of the plant are properly calibrated.

- Start the pump and check that the water flow is correct.
- Set the desired fluid temperature on the control board.
- Start the appliance (see Chapter 6).
- Check the correct direction of rotation of compressors. Scroll compressors cannot compress the refrigerant when they rotate in the opposite direction. To make sure that they are rotating in the correct direction, simply check that, just after the start-up of the compressor, the pressure drops on the LP side and rises on the HP side. Furthermore, if a scroll compressor rotate in the opposite direction, there is a considerable rise in the sound level of the unit, as well as in a dramatic reduction of current absorption compared to normal values. In case of wrong rotation, the scroll compressor can be definitely damaged. Phase monitor is assembled in the unit as a standard to prevent wrong compressors rotation.
- After about 15 minutes of operation check that there are no bubbles, through the sight glass on the liquid line.



The presence of bubbles may indicate that a part of the refrigerant charge has been released in one or more points. It is important to remove these leaks before proceeding.

- Repeat the start-up procedure after removing the leaks.

5.3 Checking the operation

Check the following:

- The temperature of the water entering the evaporator.
- The temperature of the water leaving the evaporator.
- The level of the water flow rate in the evaporator, if possible.
- The current absorption upon the start of the compressor and in case of stabilised operation.
- The fan's current absorption.

Check that the condensing and evaporation temperatures, during operation at high and low pressure detected by the pressure gauges of the refrigerant, are within the following range :

(On the units not provided with HP/LP pressure gauges for the refrigerant, connect a pressure gauge to the Shrader valves on the refrigeration circuit).

| | |
|----------------|---|
| HP side | Approx. 15 to 20 °C above the temperature of the air entering the condenser, for R410A units. |
| LP side | Approx. 2 to 4 °C below the temperature of the leaving chilled water, for R410A units. |

5.4 Delivery to the customer

- Train the user according to the instructions provided in Section 6.

6 - Control

6 General information

Introduction

This document contains the information and the operating instructions.

Main characteristics

- simple user interface with possibility to customize keys functions and to set menus visibility
- parameter setting through keyboard or PC
- thermoregulation → inlet/outlet water probe, according to customer need / application
- auto-adaptive set-point
- dynamic set-point
- alarm log
- analogue input (to be set) → NTC, 4..20mA, 0..1V, 0..5V, 0..10V
- digital input → to be set by parameter
- automatic changeover
- analogue condensation control
- advanced pump management

The following accessories can be also connected:

- multi Function Key (MFK) to upload / download parameters map
- serial communication RS485 card; to connect the control to a BMS network
- remote display terminal
- wire remote control

6.1 Control of a single compressor unit

Units are provided with a microprocessor card fully programmed by default.

General information

The figure shows the terminal. It is provided with a 4 red digits with 7 segments with decimal point led, 18 LED and 4 buttons, so as to allow the programming of the control parameters (setpoint, differential bands, alarm thresholds) and the main operations to be carried out by the user.













6.2 Keypad functions





| KEY | DESCRIPTION | SINGLE PUSH (PUSH /RELEASE) |
|-----|-------------|---|
| | UP | - Increase value - Go to next label - Change Set-point |
| | DOWN | - Decrease value - Go to previous label - Change Set-point (if UI25 =1) |
| | ESC | - Exit without saving - Go to previous level |
| | SET | - Confirm value / exit with setting saving - Go to next level - Go to status menu |

| LINKED FUNCTION | EXTENDED PUSH (MORE THAN 3s) | MENU/NOTES |
|-----------------|--------------------------------------|------------------------------|
| / | - Enable Sanitary Hot Water function | |
| / | - Stand-by → ON | - Stand-by - Local ON/OFF |
| / mode | - Change mode | - Mode menu |
| / disp | - Main display | - Display menu |

| KEYS COMBINATION | LINKED FUNCTION | MENU/NOTES |
|------------------|---------------------------|-------------------|
| | - Enable / Disable | - Time slots menu |
| | - Enter in "Program Menu" | - Program Menu |

6 - Control (continued)

| ICON / COLOR | STEADY ICON | BLINKING ICON |
|---|-------------------------------------|---|
|  / RED | - Alarm ON | - Alarm QUIT |
|  / GREEN | - Mode: HEATING | - Antifreeze + Heat pump ON - Heating mode by remote |
|  / GREEN | - Mode: COOLING | - Cooling mode by remote |
|  / GREEN | - Mode: STAND-BY | - Stand-by mode by remote |
|  / GREEN | / | / |
|  / GREEN | - Configurable | - Configurable |
|  / RED | - Current HR - Time slots activ. | - HR setting - Time slots programming |
|  / RED | / | / |
|  / RED | / | / |
|  / RED | Not used | Not used |
|  / RED | Menu surf | / |

| LED N** | DESCRIPTION | ICON |
|---------|---------------------------------|---|
| 1 | First capacity step |  |
| 3 | Primary circuit pump |  |
| 5 | Electrical heater |  |
| 6 | Sanitary hot water valve / pump |  |
| 7 | Boiler |  |

6.3 Folder structure

Folder structure is composed of totally four menus

- 1) Main display → used to set what to display without acting on any key
 - Ai → analogue input (temperature, pressure)
 - rtC → room time clock
 - SetP → standard set-point
 - SetR → corrected set-point (according to climatic correction, etc.)
- 2) Operating mode → used to set operating mode
 - StbY → stand-by
 - HEAT → heating
 - COOL → cooling
 - AS → sanitary hot water
- 3) Status → used to show resources values
 - Ai (AIL/AIE/Air) → analogue inputs (main board / expansion board / remote terminal)
 - di (diL/diE) → digital inputs (main board / expansion board)
 - AO (AOL/AOE) → analogue outputs (main board/expansion board)
 - CL (HOUr/dAtE/YEAR) → clock
 - AL (Er00 → Er98) → alarms
 - SP → standard set-point
 - Sr → corrected set-point (according to climatic correction, etc.)
- 4) Program → define parameters, functions, password and to display alarm log

6.4 Menu structure

“Program” menu is composed of totally four folders

- 1) Parameters → change unit parameters
- 2) Functions → manual operations (switch ON / switch OFF; alarm quit, historic alarm delete, multi function key use)
- 3) Password → define visibility levels for parameters/folders
- 4) Alarm log → display alarm log

Parameter folder gives access to following sub-folders

- CL/CE/Cr/CF → configure device I/O (L → local; E → expansion; r → remote; F → serial)
 - analogue inputs (type of probe, range, differential, logic function)
 - digital inputs (logic function)
 - digital outputs (logic function)
 - analogue outputs (range)
 - serial configuration (communication parameters)
- TR → define thermoregulation parameters
 - set-point (max/min/hysteresis)
 - type (proportional/differential)
 - probe selection
- ST → define operating status
 - cooling only
 - heating only
 - scooling and heating
 - change-over
- CP → configure compressor parameters (type/number/timing)
- PI → define primary circuit / source side circuit pump parameters / functions
 - operating mode (disable / always ON / ON if compressor ON)
 - digital / analogue control
 - anti-sticking
 - anti-freeze
- BR → control the parameters for an additional step for heating and for sanitary hot water integration (boiler)
 - operating mode (disable / differential → fixed or in function of outdoor air temperature)
 - set-point / hysteresis
- DS → define set-point offset (dynamic set-point) depending on
 - analogue input (0...1V, 0...5V, 0...10V, 4...20mA)
 - outdoor air temperature
 - room temperature
- AD → simulate an electronic inertial accumulator, acting on set-point and hysteresis (adaptive function), by confronting minimum / effective ON-OFF time
- AS → define sanitary hot water management parameters
 - operating mode (disable / sanitary hot water valve / resistance / pump)
 - set-point / hysteresis
 - anti-legionella function
- HP → define heat pump block management parameters
 - outdoor air temperature
 - thermoregulation temperature
 - digital input
- PL → define capacity limitation to protect the unit (high/low T, high/low P)
- TE → define time slots management (different operating daily profiles)
- AL → define alarms management (automatic / manual reset, bypass time, sampling)

6 - Control (continued)

6.5 Alarm list

| Code | Alarm unit description | CPS status | RESET auto/man | Internal circuit pump status | Fans status | Sanitary valve / heater status |
|------|---------------------------------------|------------|----------------|------------------------------|-------------|--------------------------------|
| Er00 | General alarm | OFF | A | OFF | OFF | OFF |
| Er01 | High pressure circuit | OFF | M | | | |
| Er05 | Low pressure circuit | OFF | A → M | | | |
| Er10 | Thermal protection - compressor | OFF | M | | | |
| Er20 | Plant side flow switch | OFF | M | OFF ⁽¹⁾ | OFF | OFF ⁽¹⁾ |
| Er21 | Thermal protection - plant side pump | OFF | A → M | OFF | OFF | |
| Er30 | Plant side antifreeze | OFF | A | | OFF | |
| Er35 | Water high temperature | OFF | A | | | |
| Er41 | Thermal protection – fans | OFF | M | | OFF | |
| Er45 | Clock failure | | A | | | |
| Er46 | Clock to be set | | A | | | |
| Er47 | LAN communication error | | A | | | |
| Er48 | Legionella set-point not reached | | A | | | |
| Er60 | RWT probe plant side failure | OFF | A | OFF | | |
| Er61 | LWT probe plant side failure | OFF | A | OFF | | |
| Er62 | Coil temperature probe failure | OFF | A | | | |
| Er66 | Sanitary hot water probe failure | OFF | A | | | |
| Er67 | Visualization probe (T/P) failure | | A | | | |
| Er68 | Outdoor air temperature probe failure | OFF | A | | | |
| Er69 | High pressure transducer failure | OFF | A | | OFF | |
| Er73 | Dinamic set-point failure | | A | | | |
| Er80 | Configuration error | | A | | | OFF |
| Er81 | Compressor maintenance | | M | | | |
| Er85 | Plant side pump maintenance | | M | | | |
| Er90 | Alarm hystoric record overcoming | | M | | | |

1) If alarm is manual type.

7 - Product Description

7.1 General Information

Units are one-block type with one refrigerant circuit. They are intended to cool down the water required for any air-conditioning application as well as any other fluid, such as for example glycol water.

These units are completely assembled at works. They are equipped with all the refrigerating connections and the internal electrical wiring required for a rapid installation on the field.

An operation test is performed after assembly, with water flowing through the refrigerant/water exchanger in order to make sure that every refrigerating circuit is properly working. The refrigerating circuits of every unit are pressure tested before inspection, drained and charged with R410A.

A low noise level is the result of a careful study. It is achieved on chillers by using technologically advanced components without negatively affecting the operation performances and limits of the units.

Models operating in cooling mode can cool down chilled water at a temperature between + 18 and - 8 °C.

All units can operate with a double set point.

Body and Frame

The base and frame of these units are made with galvanized steel elements, assembled with stainless steel screws. All panels can be removed to ensure easy access to internal components. All galvanized steel parts are protected by epoxy powder paint.

Compressors

The models are equipped with a single SCROLL compressor with an internal motor protection.

The compressors of all models are assembled on rubber shock absorbers. Their motors can be directly started. They are cooled down by the aspirated refrigerant gas and equipped with internal thermistor protections against overloads.

Overload protections are automatically reset after having tripped. The compressor terminal box has an IP21 protection degree.

Compressors are powered on and off by the microprocessor of the unit control system which is intended to control the delivery of the thermal refrigerating capacity.

Evaporators (SyScroll Air CO)

Evaporators are made of stainless steel plates. They are thermally insulated by means of a thick flexible insulating mattress with closed cells. The maximum operating pressures correspond to 10 bar for the water side and to 45 bar for the refrigerant side. Antifreeze protection for the water in the exchangers is ensured by electrical heaters and differential pressure switches. The water side of these exchangers is connected by manifolds which will provide for the connection to the plant by means of one single 1"1/2 (for the size 20-35) and 2" (for the size 40-75) gas threaded attachment.

Condensing coils

Condensers are made of copper tubes arranged in staggered rows and mechanically expanded inside an aluminium finned pack.

The maximum operating pressure on the refrigerant side of the condensing coils is 45 bar.

Condenser Fans

The condenser fans are of a helical type. They are directly coupled and have an impeller with wing contoured aluminium blades. Each fan is equipped with a galvanised steel accident-prevention protection which is painted after manufacture. The fans motors are completely closed. They have an IP54 protection degree and a protection thermostat embedded in the windings.

Fans Control

All models are equipped with a fan speed controller as a standard. It will act according to condensing pressure and allow the operation down to - 10 °C outdoor air temperature.

Refrigerating Circuits

Each unit has a single refrigerating circuit equipped with an external service valves intended to measure the refrigerant pressure and charge, a sight glass with a humidity indicator, a dryer filter and a thermal expansion valve.

Refrigerating circuits are also complete with a high and low pressure switch as well as a high pressure transducer.

Control Supply Panel

All components of the control system and those necessary to start the motors are shop connected and tested. The control compartment contains an electronic card and a control board with an external keyboard and display, to show the operational functions, as well as the intervention of the alarms and the working blocks.

7 - Product Description

7.2 Accessories

Water Filter

1" 1/4 filter is included in the supplied equipment.

It is supplied loose and has to be mounted by the customer.

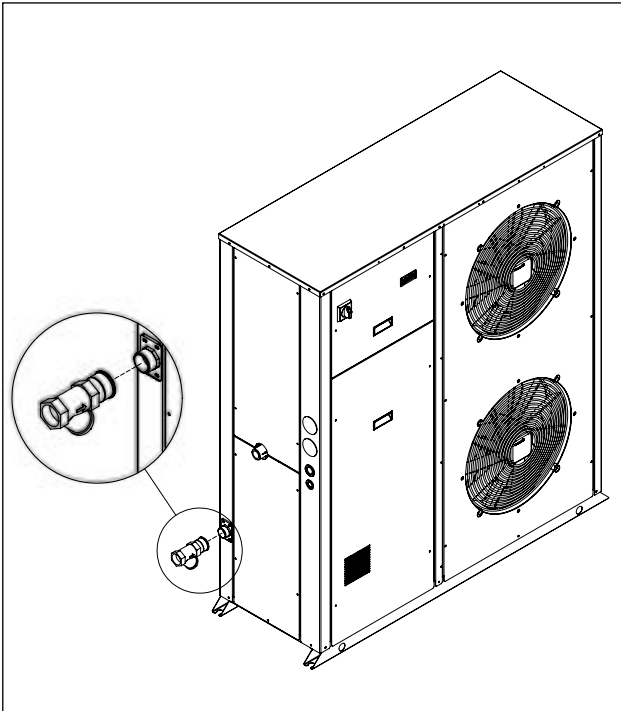

Anti-Vibration Kit

Anti-vibration kit made of special rubber pad is provided together with the unit.

Water Differential Pressure Switch

Water differential pressure switch is mounted as standard in the unit.

Flow switch kit

Flow switch kit is available as an accessory. It is supplied loose and has to be mounted by the customer. Connect terminals 1-2 of the flow switch with terminals 1-2 (Y1 user terminal).

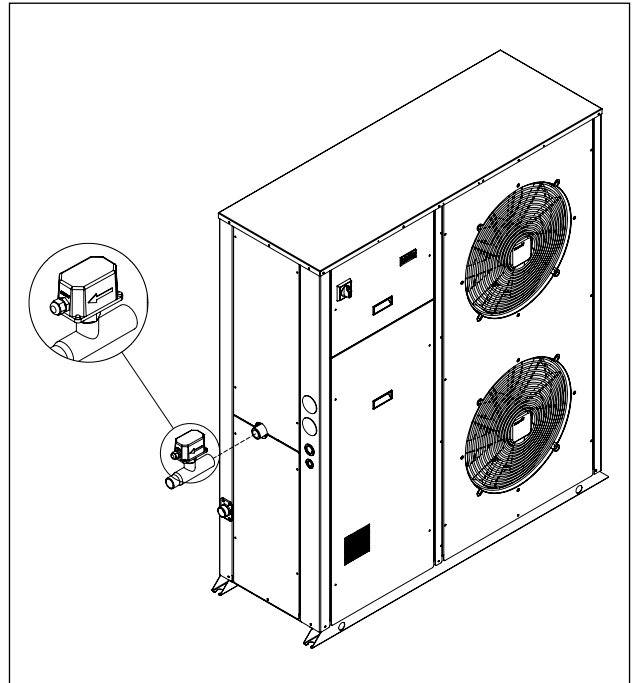

Corrosion proofing protection for condensing

Two-level optional coil finishing:

- 1) E-coating.
- 2) Blue fins.

Intrusion proofing protection for condensing

A galvanised and painted steel wire net protection is available to protect from coil fins.

Pump

Min. 100 kPa head pressure pump is mounted as a standard in the unit.

Phase Monitor Kit

It is assembled on the unit as a standard.

7 - Product Description

Airway Packaging

Complete wooden package for units without refrigerant and with nitrogen precharge. No refrigerant charge is shipped loose with the unit. The customer has to fill the unit through the apposite connection.

Water buffer tank

The hydro module is available for the units with a pump. It is installed beneath the unit through the connection pipe supplied with the unit.

The module is entirely enclosed in a galvanised and painted steel body. The tank is completely insulated with 30 Kg/m3 closed cell polyethylene in a silver colour.

Antifreeze resistances or a heating booster kit are installed in the tank (upon request).

On/Off Remote Kit

It enables the operator to power on the unit when it is in standby mode to display alarms. The kit will include a 3 metre long cable for installation on the wall.

Sequencer kit - 4 units (SyScroll Air CO)

It can easily pilot up to 4 units fitted in parallel, 50 metres maximum apart.

Gauge kit

Gauge kit is available as accessory. It is shipped loose and it's not possible to have it factory mounted.

In/out valve kit

In/Out valve kit is available as accessory.

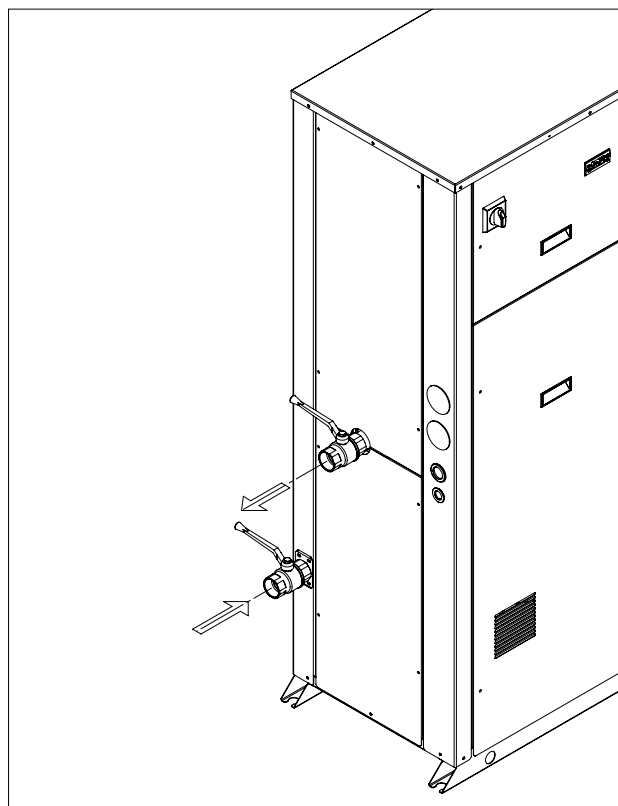

7 - Product Description

7.3 Refrigerant flow diagram - SYSCROLL 20-35 Air CO - R410A

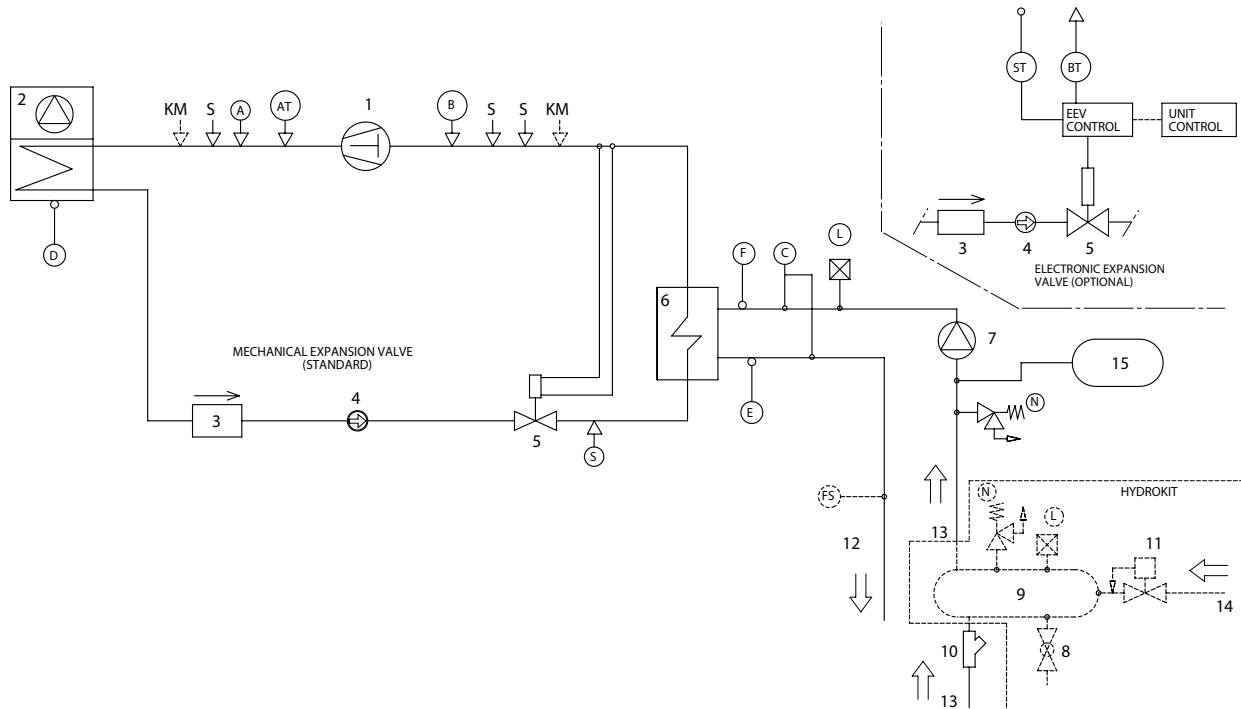

| COMPONENTS | |
|------------|--------------------------------|
| 1 | Compressor Scroll |
| 2 | Air cooled condenser |
| 3 | Filter drier |
| 4 | Sight glass |
| 5 | Thermostatic expansion valve |
| 6 | Plate heat exchanger |
| 7 | Pump |
| 8 | Drain valve |
| 9 | Water buffer tank |
| 10 | Water filter (loose) |
| 11 | Automatic water charging valve |
| 12 | Water outlet |
| 13 | Water inlet |
| 14 | Water charging line |
| 15 | Pressure expansion tank (5l) |

| SAFETY/CONTROL DEVICES | | | |
|------------------------|------------------------------------|-------|------------------------------------|
| A | High pressure switch | L | Vent valve |
| AT | High pressure transducer | N | Water safety valve |
| BT | Low pressure transducer | S | Shrader valve (charging point) |
| B | Low pressure switch | ST | Suction temperature probe |
| C | Water differential pressure switch | KM | Gauge kit (optional) |
| D | Air temperature sensor | | |
| E | Outlet water temperature sensor | | |
| F | Inlet water temperature sensor | | |
| FS | Flow switch | | |
| | | ↓ | Pipe connection with Shrader valve |
| | | ----- | Optional parts |
| | | ○ | Sensors |

7 - Product Description

Refrigerant flow diagram - SYSCROLL 20-35 Air RE - R410A

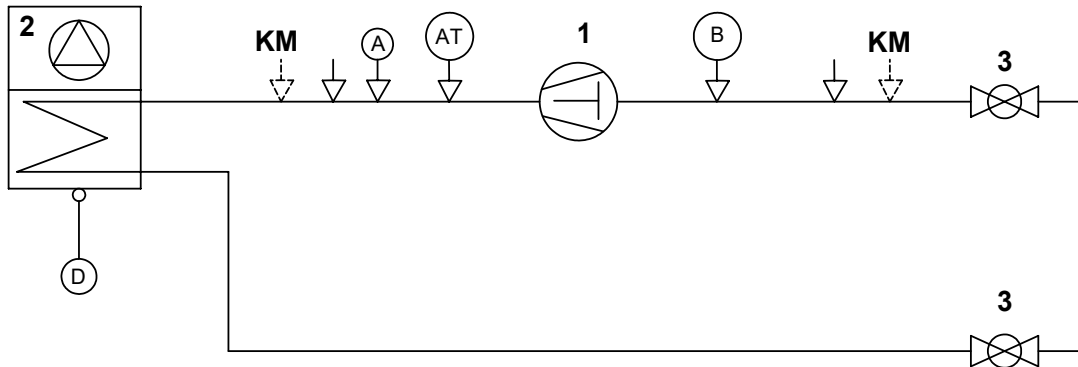

| COMPONENTS | |
|------------|------------------------|
| 1 | Compressor scroll type |
| 2 | Air cooled condenser |
| 3 | Global Valve |

| SAFETY/CONTROL DEVICES | | |
|------------------------|--|-------|
| A | High pressure switch (42 bar) | ↓ |
| AT | High pressure transducer | ↓ |
| B | Low pressure switch (1,5 bar) | ----- |
| D | Air temperature sensor | |
| S | Shrader valve (service/charging point) | |
| KM | Manometer (optional) | |

8 - Technical Data

8.1 Hydraulic Features

Unit available pressure and Circuit pressure drop

Pump available pressure

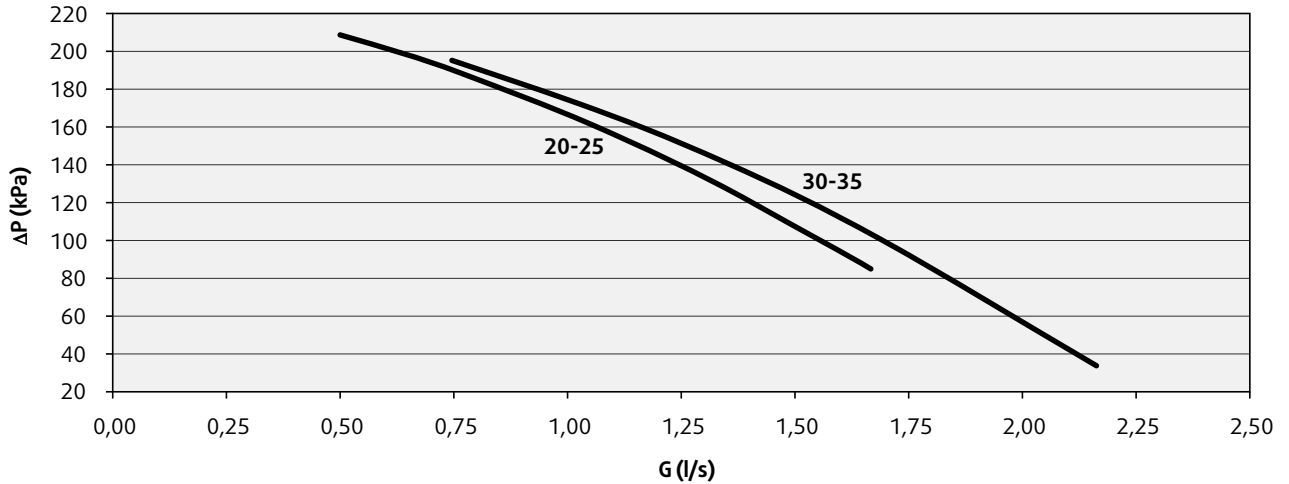

Circuit pressure drop

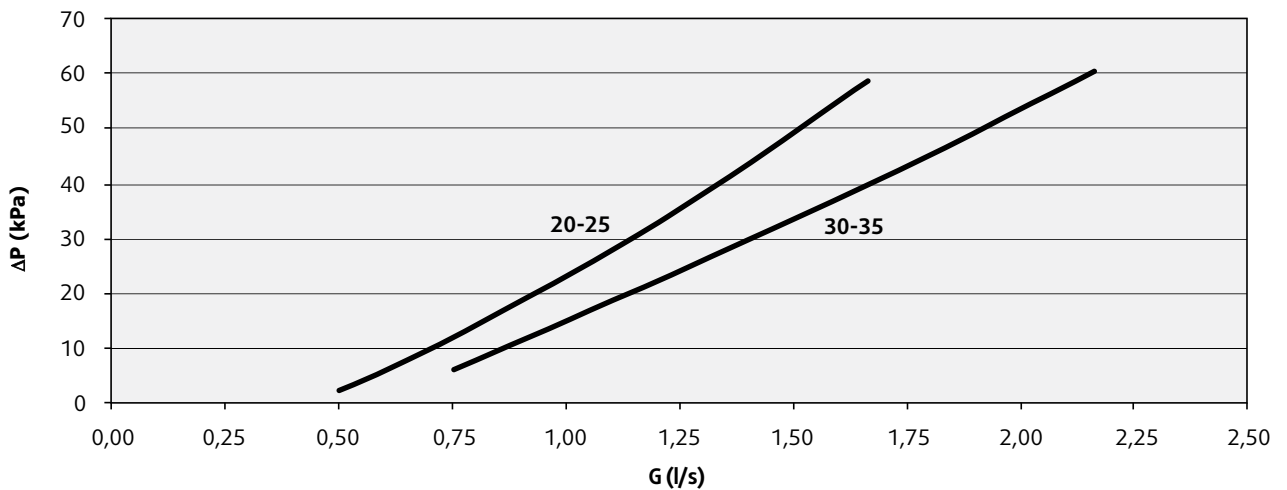

Filter pressure drop*

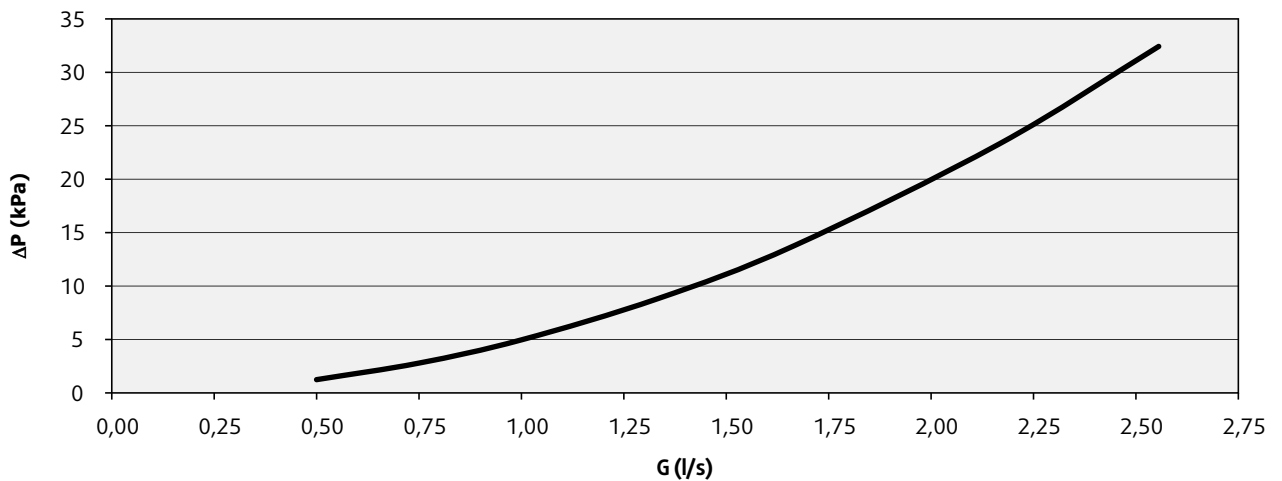

* 1"1/4 diameter, filtration capacity 500 μm / 35 mesh

8 - Technical Data

8.2 Physical data

SYSCROLL 20-35 Air CO

| SYSCROLL Air CO | | 20 | 25 | 30 | 35 |
|---|---------------------|---------------------|-------|-------|-------|
| Power supply | V/ph/Hz | 400(±10%)/3+N/50 | | | |
| Number of refrigerant circuits | | 1 | | | |
| Total capacity steps | % | 0-100 | | | |
| REFRIGERANT | | | | | |
| Type / GWP | | R410A / 2.088 | | | |
| Charge (1) | kg | 4,1 | 5,2 | 5,5 | 5,8 |
| | tCO ₂ eq | 8,56 | 10,86 | 11,48 | 12,11 |
| COMPRESSOR | | | | | |
| Type | | Scroll | | | |
| Number | | 1 | | | |
| Start-up type | | Direct | | | |
| Oil type | | POE | | | |
| N° of loading stages | | 0/100 | | | |
| EVAPORATOR | | | | | |
| Type | | Plate | | | |
| Number | | 1 | | | |
| Water flow Rate | l/s | 0,97 | 1,14 | 1,32 | 1,59 |
| Pressure drop | kPa | Refer to Chapt. 8.1 | | | |
| FANS | | | | | |
| Type | | Axial | | | |
| Number | | 2 | 2 | 2 | 2 |
| Nominal speed | rpm | 630 | 630 | 630 | 630 |
| Air flow rate | m ³ /s | 3,1 | 3,6 | 3,6 | 3,5 |
| Power input | kW | 0,6 | 0,6 | 0,6 | 0,6 |
| AIR COOLED CONDENSER | | | | | |
| Type | | Finned tubes | | | |
| Number | | 1 | | | |
| Total coil face area per coil | m ² | 1,5 | 1,5 | 1,5 | 1,5 |
| PUMP | | | | | |
| Type | | Centrifugal | | | |
| Number | | 1 | | | |
| Nominal speed | rpm | 2850 | | | |
| Power input | kW | 0,6 | 0,62 | 0,64 | 0,66 |
| HYDRAULIC CONNECTIONS (EVAPORATOR) | | | | | |
| Type | | Threaded gas male | | | |
| Inlet Diameter | inch | 1" 1/4 | | | |
| Outlet Diameter | inch | 1" 1/4 | | | |
| WEIGHT | | | | | |
| Shipping Weight | kg | Refer to Chapt. 8.5 | | | |
| Operating Weight | kg | | | | |
| DIMENSIONS | | | | | |
| Length | mm | 1477 | | | |
| Width | mm | 539 | | | |
| Height | mm | 1615 | | | |

(1) The refrigerant value are indicative values for standard units. The actual data are indicated on the unit label.

8 - Technical Data

SYSCROLL 20-35 Air RE

| SYSCROLL Air RE | | 20 | 25 | 30 | 35 |
|--------------------------------|----------------------|---------------------|--------|-------|-------|
| Power supply | V/ph/Hz | 400 ± (10%)/3+N/50 | | | |
| Number of refrigerant circuits | | 1 | | | |
| Total capacity steps | % | 0-100 | | | |
| REFRIGERANT | | | | | |
| Type / GWP | | R410A / 2.088 | | | |
| Charge (1) | kg | 4,1 | 5,2 | 5,5 | 5,8 |
| | tCO ₂ ,eq | 8,56 | 10,86 | 11,48 | 12,11 |
| COMPRESSOR | | | | | |
| Type | | Scroll | | | |
| Number | | 1 | | | |
| Start-up type | | Direct | | | |
| Oil type | | POE | | | |
| N° of loading stages | | 0/100 | | | |
| FANS | | | | | |
| Type | | Axial | | | |
| Number | | 2 | | | |
| Nominal speed | rpm | 900 | | | |
| Air flow rate | m³/s | 3,0 | 2,9 | 2,9 | 2,8 |
| Power input | kW | 0,54 | 0,54 | 0,54 | 0,55 |
| EXTERNAL HEAT EXCHANGER | | | | | |
| Type | | Finned tubes | | | |
| Number | | 1 | | | |
| Frontal area | m² | 1,5 | 1,5 | 1,5 | 1,5 |
| REFRIGERANT CONNECTIONS | | | | | |
| Inlet diameter | inch | 7/8" | 1 1/8" | | |
| Outlet diameter | inch | 1/2" | 1/2" | | |
| WEIGHT | | | | | |
| Shipping weight | kg | Refer to Chapt. 8.5 | | | |
| DIMENSIONS | | | | | |
| Length | mm | 1477 | | | |
| Width | mm | 539 | | | |
| Height | mm | 1615 | | | |

(1) The value is representing the contribution to the global refrigerant charge given by the standard unit only. Contribution of connection piping and remote evaporator is not included here.

| SYSCROLL Air RE | Unit connections | | Suction line dimensions (inch) | | | Liquid line dimensions (inch) | | |
|-----------------|------------------|--------|--------------------------------|--------|--------|-------------------------------|------|------|
| | Suction | Liquid | Total equivalent length (m) | | | Total equivalent length (m) | | |
| | (inch) | (inch) | 10 | 20 | 30 | 10 | 20 | 30 |
| 20 | 7/8" | 1/2" | 7/8" | 7/8" | 1 1/8" | 1/2" | 5/8" | 5/8" |
| 25 | 1 1/8" | 1/2" | 1 1/8" | 1 1/8" | 1 1/8" | 5/8" | 5/8" | 3/4" |
| 30 | 1 1/8" | 1/2" | 1 1/8" | 1 1/8" | 1 1/8" | 5/8" | 5/8" | 3/4" |
| 35 | 1 1/8" | 1/2" | 1 1/8" | 1 1/8" | 1 3/8" | 5/8" | 5/8" | 3/4" |

8 - Technical Data

8.3 Electrical data

| SYSCROLL Air CO/RE | | 20 | 25 | 30 | 35 |
|---------------------------|-----------------|-----------------------------|-----|-----|-----|
| Rated voltage | V/ph/Hz | 400 ($\pm 10\%$)/3+N/50 | | | |
| Max. absorbed power | kW | 10 | 12 | 13 | 16 |
| Max. current FLA | A | 20 | 25 | 26 | 35 |
| Max. start-up current LRA | A | 105 | 115 | 122 | 144 |
| External fuses | A | 25 | 25 | 32 | 32 |
| Max. cable section (*) | mm ² | 6 | 6 | 10 | 10 |
| EXCHANGER RESISTANCE | | | | | |
| Rated voltage | V/ph/Hz | 230 ($\pm 10\%$) / 1 / 50 | | | |
| Max. absorbed power | W | 70 | 90 | 90 | 90 |

(*) The dimensioning of the unit's power cables is the responsibility of the installer, who shall consider: the rating, the maximum working temperature in the room, the type of insulation and the cable laying, the maximum length of the power supply line.

Compressor electrical data

| SYSCROLL Air CO/RE | | 20 | 25 | 30 | 35 |
|---------------------|---------|-----------------------------|----|----|----|
| Rated voltage | V/ph/Hz | 400 ($\pm 10\%$) / 3 / 50 | | | |
| Number | | 1 | | | |
| Max. absorbed power | kW | 9 | 10 | 12 | 15 |
| Rated current | A | 16 | 21 | 22 | 31 |
| Oil pan resistor | W | 70 | 90 | 90 | 90 |

Fan electrical data

| SYSCROLL Air CO/RE | | 20 | 25 | 30 | 35 |
|------------------------|---------|-----------------------------|----|----|----|
| Rated voltage | V/ph/Hz | 230 ($\pm 10\%$) / 1 / 50 | | | |
| Number | | 2 | | | |
| Max. absorbed power | kW | 0,3+0,3 | | | |
| Absorbed rated current | A | 1,3+1,3 | | | |

Pump electrical data

| SYSCROLL Air CO/RE | | 20 | 25 | 30 | 35 |
|------------------------|---------|-----------------------------|----|----|----|
| Rated voltage | V/ph/Hz | 400 ($\pm 10\%$) / 3 / 50 | | | |
| Number | | 1 | | | |
| Max. absorbed power | kW | 0,72 | | | |
| Absorbed rated current | A | 1,30 | | | |

8 - Technical Data

8.4 Position of shock absorbers and weight distribution on supports

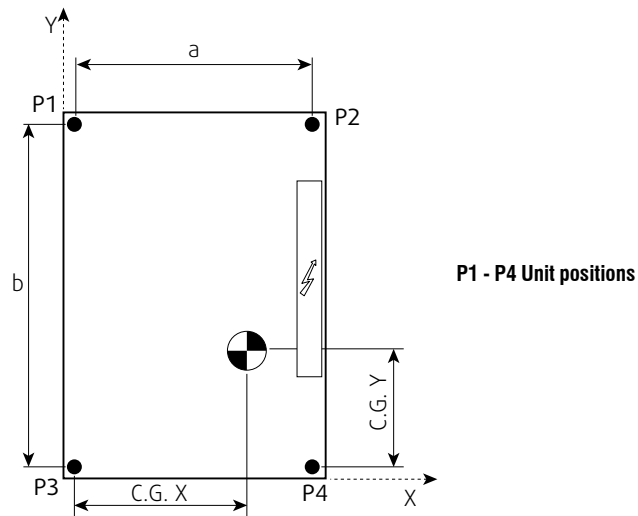

| | SIZE | Weight distribution | | | | Operating weight | Shipping weight | Coordinates P1-P4 | | Coordinates CG | |
|--------------|------|---------------------|----|----|----|------------------|-----------------|-------------------|------|----------------|-----|
| | | P1 | P2 | P3 | P4 | | | a | b | x | y |
| | | kg | kg | kg | kg | | | mm | mm | mm | mm |
| 20-35 Air CO | 20 | 54 | 59 | 64 | 69 | 248 | 254 | 457 | 1441 | 264 | 680 |
| | 25 | 62 | 65 | 74 | 77 | 279 | 285 | 457 | 1441 | 260 | 676 |
| | 30 | 62 | 66 | 76 | 79 | 283 | 289 | 457 | 1441 | 260 | 669 |
| | 35 | 68 | 68 | 81 | 81 | 298 | 304 | 457 | 1441 | 255 | 677 |
| 20-35 Air RE | 20 | 47 | 53 | 57 | 63 | | 228 | 457 | 1441 | 264 | 680 |
| | 25 | 55 | 59 | 67 | 71 | | 259 | 457 | 1441 | 260 | 676 |
| | 30 | 55 | 60 | 69 | 73 | | 263 | 457 | 1441 | 260 | 669 |
| | 35 | 61 | 62 | 74 | 75 | | 278 | 457 | 1441 | 255 | 677 |

| | SIZE | Weight distribution | | | | Operating weight | Shipping weight | Coordinates P1-P4 | | Coordinates CG | |
|----------------------------|------|---------------------|-----|-----|-----|------------------|-----------------|-------------------|------|----------------|-----|
| | | P1 | P2 | P3 | P4 | | | a | b | x | y |
| | | kg | kg | kg | kg | | | mm | mm | mm | mm |
| 20-35 Air CO + Hydrokit | 20 | 99 | 104 | 109 | 114 | 427 | | 457 | 1441 | 260 | 705 |
| | 25 | 107 | 110 | 119 | 122 | 458 | | 457 | 1441 | 258 | 701 |
| | 30 | 107 | 110 | 121 | 124 | 462 | | 457 | 1441 | 258 | 696 |
| | 35 | 113 | 113 | 126 | 126 | 477 | | 457 | 1441 | 255 | 700 |

8 - Technical Data

8.5 Dimensional Drawings - SYSCROLL 20-35

Front view

Side view

Rear view

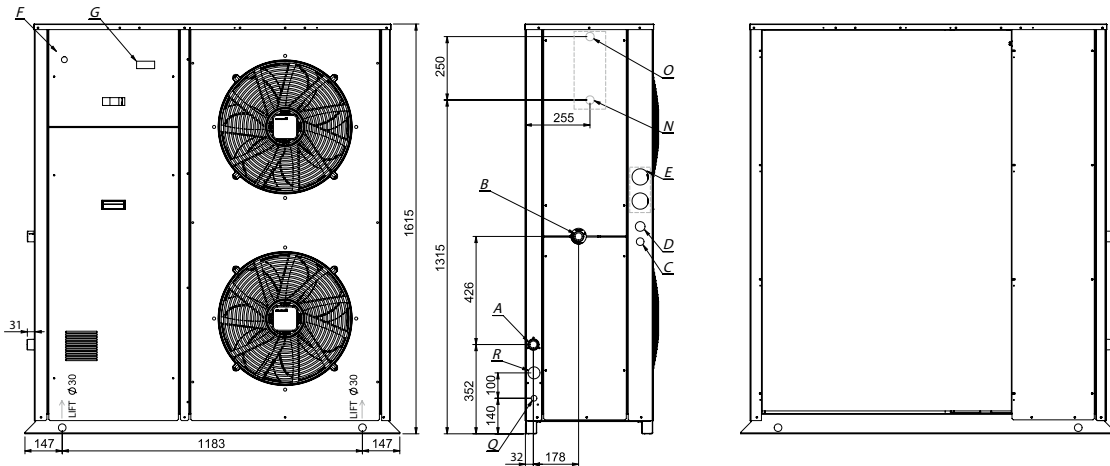

Top view

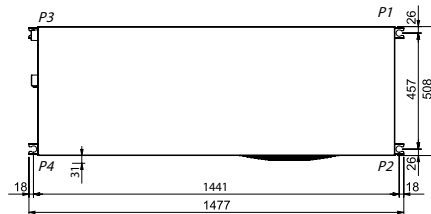

| NOTES: | |
|--------|--|
| A | Water inlet Ø1 1/4" MGT |
| B | Water outlet Ø1 1/4" MGT |
| C | Auxiliary lines |
| D | Electrical power supply |
| E | Gauge kit (optional) |
| F | Main switch |
| G | Control keypad/display |
| N | Desuperheater water inlet 1" Gas M |
| O | Desuperheater water Outlet 1" Gas M |
| Q | Liquid Line ø 1/2" |
| R | Suction Line ø 1 1/8" ø 7/8" (only SYSCROLL 20) |

Dimensions in mm.

8 - Technical Data

8.6 Dimensional Drawings - SYSCROLL 20-35 CO + HYDROKIT

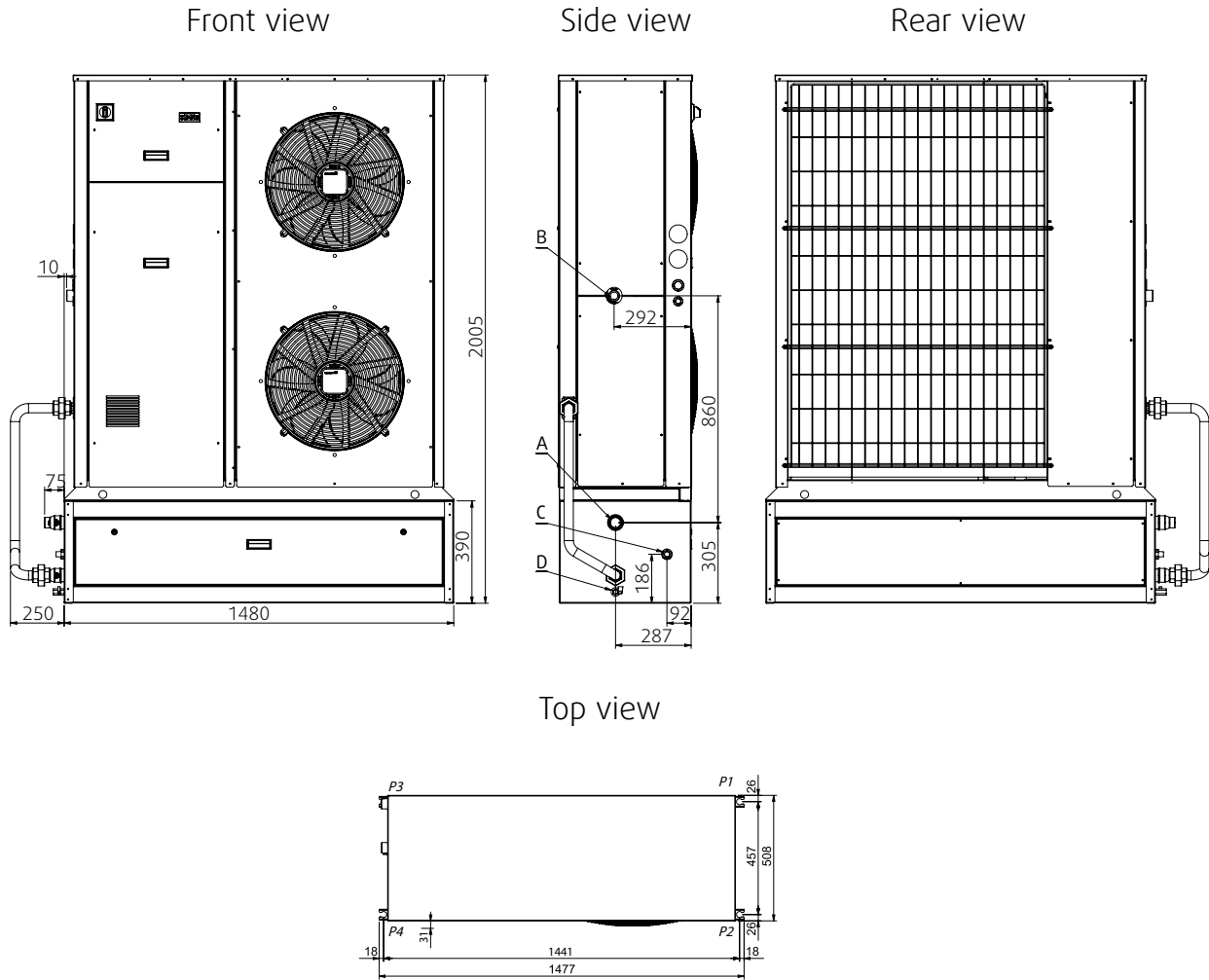

| NOTE: | |
|-------|--------------------------|
| A | Water inlet Ø1 1/4" MGT |
| B | Water outlet Ø1 1/4" MGT |
| C | Water charge ø 1/2" MGT |
| D | Water drain ø 3/8" FGT |

8 - Technical Data

8.7 Space Requirements

SYSCROLL 20-35 Air

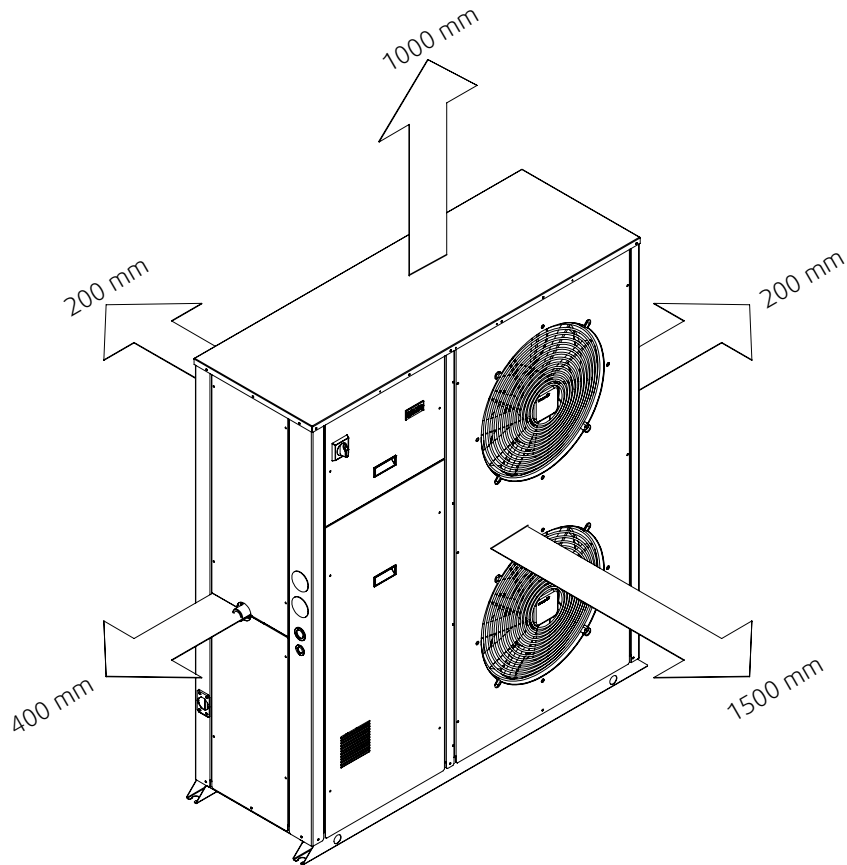

9 - Maintenance

Carefully read the “Safety” section of this manual before carrying out any maintenance operations.

| | |
|---|---|
|  | <p>Do not discharge the refrigerant into the atmosphere while the refrigeration circuits are being drained. Use appropriate recovery equipment.</p> <p>When the recovered refrigerant cannot be re-used, return it to the manufacturer.</p> |
|---|---|

| | |
|---|---|
|  | <p>Do not throw away the waste oil of the compressor, because it contains refrigerant in solution.</p> <p>The waste oil must be returned to the manufacturer.</p> |
|---|---|

Unless otherwise specified, the operations described below may be carried out only by a trained maintenance operator.

9.1 General requirements

Units have been designed for continuous operation, providing that they are subjected to regular maintenance, within the limits specified in this manual. Each unit must be serviced according to the programme by the User/Customer, and must be inspected at regular intervals by the personnel of one authorised Service Centers.

It is the responsibility of the User to meet these maintenance requirements and/or to enter into an agreement with one of authorised Service Centers, so as to properly safeguard the operation of the appliance.

During the warranty period, in case of damage or failures caused by improper maintenance, manufacturer will not refund the costs incurred to repair the appliance in its original state.

The provisions of this section apply only to standard units; according to the order requirements, other documentation may be added, concerning any modifications or supplementary accessories.

9.2 Planned maintenance

Maintenance inspections must be carried out according to the program below, by a qualified person.

As a general rule, units cannot be repaired directly by the user, who shall not try to service or repair any failures or anomalies identified during daily inspections. If you are in doubt, please contact authorised Service Centre.

| Operations | Daily | Weekly | Monthly | Beginning of season | End of season |
|---|-------|--------|---------|---------------------|---------------|
| Check the temperature of the leaving fluid | ● | | | | |
| Check the pressure drops in the heat exchanger | | ● | | | |
| Check for electric absorption | | ● | | | |
| Check suction pressure and temperature | | ● | | | |
| Check delivery pressure and temperature | | ● | | | |
| Check the oil level in the compressor | | ● | | | |
| Check that there are no gas bubbles in the liquid line | | ● | | | |
| Check that the fins of the external coil are clean (if any) | | | ● | | |
| Check the operation of the oil heaters | | | ● | | |
| Check the remote control switches | | | ● | | |
| Check the operation of the LP pressure switch | | | | ● | |
| Check the operation of the HP pressure switch | | | | ● | |
| Check the insulation of the heat exchanger | | | | ● | |
| Check that terminals are tightened | | | | ● | |
| Check that the terminals' screws are tightened | | | | ● | |
| Clean the exterior of the unit with water and soap | | | | ● | |
| Check the density of the antifreeze (if any) | | | | ● | ● |
| Check the operation of the flow switches | | | | ● | |
| Check the operation of the solenoid valve | | | | ● | ● |

9 - Maintenance

9.3 Refrigerant charge

| | |
|---|---|
|  | <p>Do not inject refrigerant liquid into the LP side of the circuit. Be very careful, and charge the circuit properly.</p> <p>If the charge is insufficient, the efficiency of the unit will be lower than expected. In the worst of cases the LP transducer may stop the unit.</p> <p>In the presence of an excess charge, the condensing pressure will rise (in the worst of cases, the HP pressure switch may be activated, resulting in the stop of the equipment), and the consumption will increase as well.</p> |
|---|---|

| | |
|---|---|
|  | <p>It is strictly forbidden to use the compressor as a vacuum pump to drain the plant.</p> |
|---|---|

Fill the refrigeration circuit after it has been drained for maintenance purposes (leaks, replacement of the compressor etc.). The amount of the charge is indicated on the plate affixed to the unit.

Before refilling, it is important to drain and de-hydrate the circuit, thus obtaining a minimum abs. pressure value of 50 Pa.

Inject the refrigerant fluid before removing the vacuum, then fill the circuit up to 90% of the total gas requirement (in liquid form). The appliance must be filled through the filling valve on the liquid line, on the outlet side of the condenser.

It is recommended to connect the refrigerant cylinder to the filling valve on the liquid line, and to arrange it in such a way as to inject only liquid refrigerant.

9.4 Compressor

Compressors are delivered with the necessary charge of lubricating oil. During normal operation, this charge is sufficient for the whole life of the unit, providing that the efficiency of the refrigeration circuit is satisfactory and if it has not been overhauled.

If the compressor needs to be replaced (following a mechanical failure or if burnt), contact one of authorised Service Centers.

| | |
|---|--|
|  | <p>Compressors use polyester oil. During maintenance operations on the compressor, or if you have to open the refrigerant circuit in any point, remember that this type of oil is highly hygroscopic, and accordingly it is important that it is not left exposed to the weather for prolonged periods, as this would require the replacement of the oil.</p> |
|---|--|

9.5 Condenser

The condenser's coils consist of copper pipes and aluminium fins. In the presence of leaks caused by any damage or shock, the coils shall be repaired or replaced by one authorised Service Center. To ensure the effective and correct operation of the condenser coils, it is important to keep the condenser's surface perfectly clean, and to check that there is no foreign matter, such as leaves, wires, insects, waste etc. If the coil becomes dirty, there is an increase in the absorption of electric energy. Furthermore, the maximum pressure alarm may be activated and may halt the unit.

| | |
|---|--|
|  | <p>Be careful not to damage the aluminium fins during cleaning.</p> |
|---|--|

The condenser must be cleaned with a LP compressed air jet, parallel to the aluminium fins, in the direction opposite to the air circulation.

To clean the coil you can use also a vacuum cleaner, or a jet of water and soap.

9.6 Fans

The fans of the condenser, of axial type, are complete with impeller with aerodynamic profile blades and a cylindrical nozzle. The motor's bearings are lubricated forever.

9.7 Dehydrating filter

The refrigeration circuits are provided with dehydrating filters.

The filter clogging is marked by the presence of air bubbles in the sight glass, or by the difference between the temperatures measured downstream from and upstream of the drying filter. If, once the cartridge has been cleaned, there are still some air bubbles, the appliance has lost a part of the refrigerant charge in one or more points, that must be identified and serviced.

9 - Maintenance

9.8 Sight glass

The sight glass is used for inspecting the refrigerant flow and the humidity % of the refrigerant. The presence of bubbles indicates that the dehydrating filter is clogged or the charge insufficient.

A colour indicator is positioned inside the sight glass. If you compare the colour of the indicator to the scale on the ring of the sight glass, you can calculate the percentage of humidity of the refrigerant. If it is excessive, replace the filter's cartridge, operate the appliance for 1 day and then check the humidity % again. When the humidity % is within the pre-determined range, no other operations are required. If the humidity % is still too high, replace the dehydrating filter again, start the unit and operate it for another day.

9.9 Thermostatic expansion valve

The circuit of the unit is equipped with a thermostatic expansion valve, with external equalizer.

The valve is factory calibrated for an overheating of 5 °C.

Procedure to check for overheating:

- Measure the suction pressure with the pressure gauges on the board of the unit or using a pressure gauge connected to the service valve on the suction side.
- From the pressure gauge's temperature scale, measure the saturated suction temperature (T_{sa}) which corresponds to the pressure value.
- Using a contact pressure gauge affixed to the outlet fitting of the gas of the evaporator, measure the actual temperature (T_{se}).

Overheating calculation (S):

$$S = T_{se} - T_{sa}$$

Overheating is regulated through the thermostatic expansion valve.

Make the adjusting screw follow a complete turn, and operate the appliance for five minutes.

Check again and, if necessary, repeat the regulation.

If the expansion valve cannot be regulated, it is probably broken, and shall be replaced. The replacement must be carried out by a Service Centre.

9.10 Evaporator

Check at regular intervals that the water side of the heat exchanger is perfectly clean. To do this, measure the pressure drop, water side (see Section 9) or measure the temperature of the liquid leaving and entering the heat exchanger, and compare it to the evaporation temperature.

To obtain an effective heat exchange, the difference between the temperature of the leaving water and the saturated evaporating temperature must be in the 2 - 4 °C range. A greater difference would indicate a low efficiency of the heat exchanger (i.e. the heat exchanger is dirty).

In this case, the heat exchanger must be subjected to chemical cleaning, an operation that shall be carried out by authorised engineers.

For other maintenance operations (extraordinary overhauling, replacement of the heat exchanger etc.), contact an authorised Service Centre.

10 - Troubleshooting

The table below lists the anomalies of operation of the unit, the relevant causes and the corrective measures. For anomalies of any other type or not listed, contact one of authorised Service Centre for technical assistance.

| Anomaly | Cause | Operation |
|--|--|--|
| The unit continues to work, but without cooling | Insufficient charge of refrigerant. | Refill. |
| | The dehydrating filter is clogged. | Replace. |
| Ice on the suction line | Wrong calibration of overheating. | Increase overheating. |
| | | Check the charge. |
| Excessive noise | Vibration of lines. | Check the clamping brackets, if any. |
| | Whistler emitted by the thermostatic expansion valve. | Refill. |
| | | Check the dehydrating filter. |
| | Noisy compressor. | Seized bearings; replace the compressor. |
| Check that the compressor's locknuts are tightened. | | |
| Low oil level in the compressor | One or more gas or oil leaks in the circuit. | Identify and remove leaks. |
| | Mechanical failure of the compressor. | Request the intervention of a Service Centre. |
| | Anomaly of the oil heater of the compressor's base. | Check the electric circuit and the resistor of the heater of the motor base, and replace defective components. |
| One or both compressors are not working | Breaking of the electric circuit. | Check the electric circuit and detect any ground dispersions and short circuits. Check fuses. |
| | Intervention of the HP pressure switch. | Reset the pressure switch and the control panel and restart the appliance. Identify and remove the cause that enabled the pressure switch. |
| | The fuse of the control circuit is broken. | Check for ground dispersions and short circuits. Replace fuses. |
| | Loosened terminals. | Check and tighten. |
| | Halt caused by thermal overload of the electric circuit. | Check the operation of check and safety devices. Identify and remove the cause. |
| | Wrong wiring. | Check wiring of check and safety devices. |
| | The line voltage is too low. | Check voltage. If problems regard the system, solve them. If they are caused by the distribution network, inform the Energy Distributor. |
| | Short-circuit of the compressor's motor. | Check the continuity of the winding. |
| Seized compressor. | Replace the compressor. | |
| Activation of the LP alarm, stop of the unit | Gas leak. | Identify and remove the leak. |
| | Insufficient charge. | Refill. |
| Activation of the HP alarm, stop of the unit | Failure of the pressure switch. | Check the operation of the pressure switch, replace it if defective. |
| | The delivery valve is partially closed. | Open the valve and replace it, if faulty. |
| | Substances with condensable gases in the circuit. | Drain the circuit. |
| | The fan of the condenser is stopped. | Check cables and motor. If defective, repair or replace. |
| The liquid line is too hot | Insufficient charge. | Identify and remove the cause of the loss of charge and refill. |
| Frosting of the liquid line | The valve of the liquid line is partially closed. | Check that valves are open. |
| | The liquid filter is clogged. | Replace the cartridge or the filter. |

11 - Spare Parts

11.1 Spare part list

The table below shows the list of spare parts recommended during the first two years of operation.

| Component | Number |
|--|--------|
| Fan | 1 |
| High pressure switch | 2 |
| Differential water pressure switch | 1 |
| High pressure transducer | 2 |
| Low pressure transducer | 2 |
| Expansion valve | 1 |
| Gas filter | 1 |
| Electronic main board | 1 |
| Auxiliary main board transformer | 1 |
| Auxiliary circuit transformer | 1 |
| Compressor contactor | 2 |
| Pump contactor | 1 |
| Water sensor | 4 |
| Air sensor | 1 |
| Automatic switch compressor protection | 2 |
| Automatic switch pump protection | 1 |
| Auxiliary contact | 4 |
| Fan capacitor | 1 |
| Auxiliary switch | 1 |
| Fuses | 4 |

11.2 Oil for compressors

The compressors are lubricated with polyester oil (P.O.E.).

11.3 Wiring diagrams

The wiring diagrams are installed inside the doors of the electrical panels of the unit. Any request for wiring diagrams shall be forwarded to manufacturer's Service Centre.

12 - Dismantling, Demolition and Scrapping



During the draining of the refrigeration circuits, do not let the refrigerant overflow in the surrounding atmosphere.

The circuit must be drained using suitable recovery equipment.



Do not disperse the waste oil of the compressors in the environment, since it contains some dissolved refrigerant.

For the disposal, contact the competent authority for information.

Unless otherwise specified, the maintenance operations listed below may be carried out by any trained maintenance operator.

12.1 Generalities

Open each line that supplies the unit, including the ones of control circuits. Make sure that all disconnecting switches are secured in the off position. The power cables can be disconnected and disassembled. Refer to Chapter 4 for the position of connection points.

Remove all the refrigerant from the refrigeration circuits of the unit and store it in suitable containers, using a recovery unit. If its characteristics have remained the same, the refrigerant can be used again. Contact the competent authority to obtain information about disposal. In **NO** event shall the refrigerant be discharged into the atmosphere. The oil in each refrigeration circuit must be drained and collected into a suitable container; then it shall be disposed of in conformity with local regulations that apply to the disposal of waste lubricants. Any oil spillage must be recovered and disposed of in like manner.

Isolate the unit's heat exchangers from the external hydraulic circuits and drain the heat exchange sections of the plant.



If no shutoff valves have been provided, it may be necessary to drain the whole plant.

If a glycoled solution or a similar fluid has been used in the hydraulic circuits, or if chemical additives have been added to the circulating water, the circulating fluid MUST be drained in a proper way.

For NO reason shall a circuit containing glycoled water or a similar solution be discharged directly into the drains or surface waters.

After draining operations, the piping of the hydraulic networks can be disconnected and disassembled.

Once they have been disconnected as specified, the packaged units can be disassembled in a single piece. First of all, disassemble the anchoring screws and then lift the unit from the position of installation, and hook it to the lifting points provided, using suitable lifting equipment.

To this end, refer to Chapter 4 for the installation of these appliances, to Chapter 9 for their weights and Chapter 3 for handling.

The units that, once disconnected, cannot be removed in a single piece, must be dismantled on site; in this case, be very careful with the weight and handling of every single component.

It is always advisable to dismantle the units following the installation steps, but in reverse.



Some residues of oil, glycoled water or similar solutions may remain in certain parts of the unit. These residues must be recovered and disposed of according to the procedures specified above.

It is very important to ensure that, while a component of the unit is being removed, all the others are properly supported.



Use only lifting means of adequate capacity.

Once disassembled, the components of the unit can be disposed of in conformity with current regulations.

12.2 RAEE Directive (only UE)



- The RAEE Directive requires that the disposal and recycling of electrical and electronic equipment must be handled through a special collection, in appropriate centers, separate from that used for the disposal of mixed urban waste.
- The user has the obligation not to dispose of the equipment at the end of the useful life as municipal waste, but to send it to a special collection center.
- The units covered by the RAEE Directive are marked with the symbol shown above.
- The potential effects on the environment and human health are detailed in this manual.

Systemair srl
Via XXV Aprile, 29
20825 Barlassina (MB)
Italy

Tel. +39 0362 680 1
Fax +39 0362 680 693

www.systemair.com

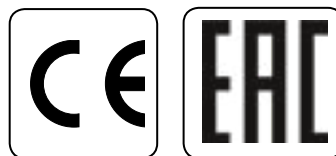

As part of our ongoing product improvement programme, our products are subject to change without prior notice. Non contractual photos.

Dans un souci d'amélioration constante, nos produits peuvent être modifiés sans préavis. Photos non contractuelles.

In dem Bemühen um ständige Verbesserung können unsere Erzeugnisse ohne vorherige Ankündigung geändert werden. Fotos nicht vertraglich bindend.

A causa della politica di continua miglìoria posta in atto dal costruttore, questi prodotti sono soggetti a modifiche senza alcun obbligo di preavviso. Le foto pubblicate non danno luogo ad alcun vincolo contrattuale.

Con objeto de mejorar constantemente, nuestros productos pueden ser modificados sin previo aviso. Fotos no contractuales.

