

Installation and maintenance manual
Manuel d'installation et de maintenance
Installations- und Wartungshandbuch
Manuale di installazione e di manutenzione
Manual de instalación y de mantenimiento

SYSCROLL 400-900 AIR EVO CO/HP/TR

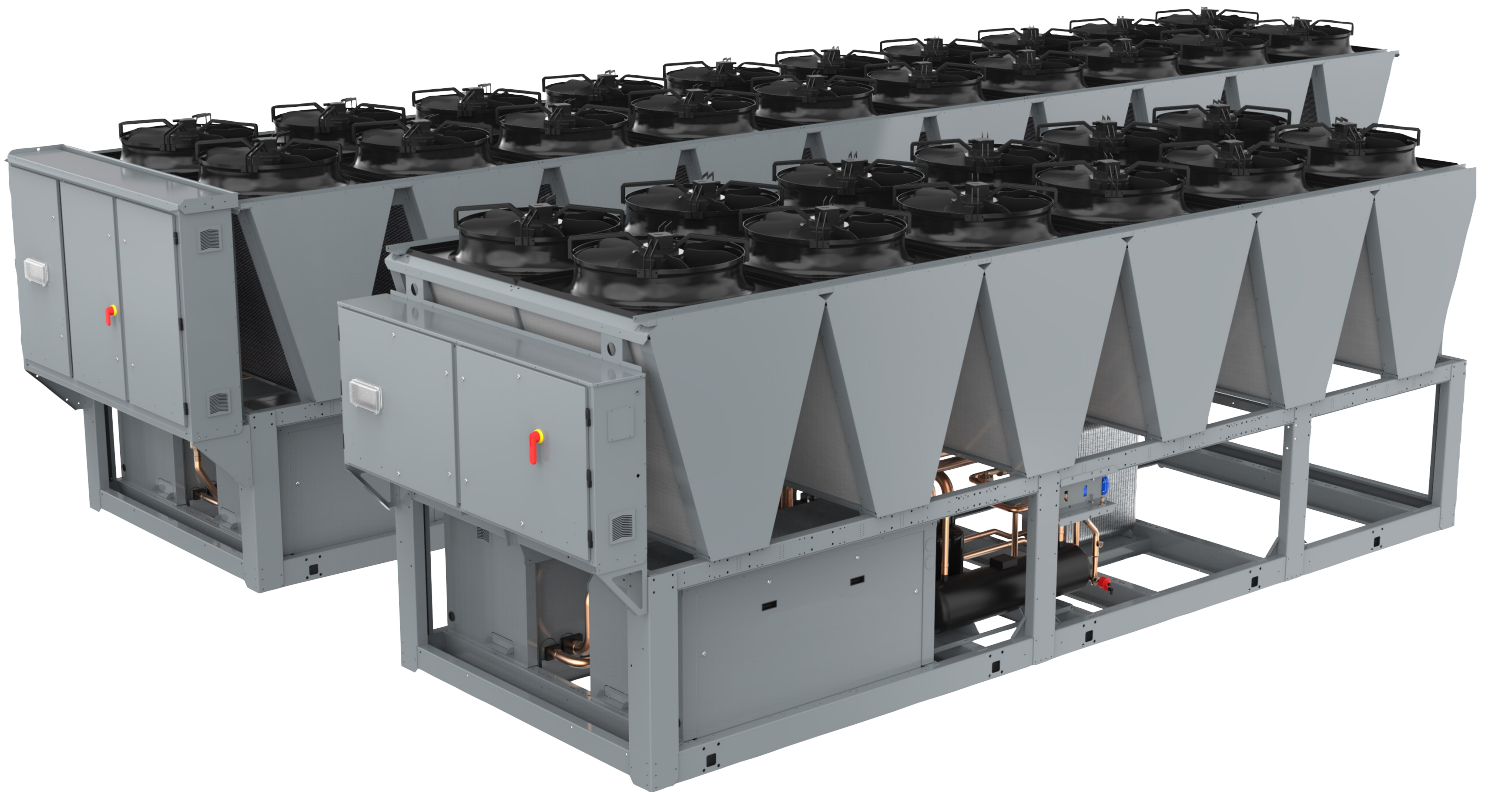

English

Français

Deutsch

Italiano

Español



399
↓
897 kW



404
↓
902 kW



Air Cooled Water Chillers and Heat Pumps

Refroidisseurs de liquide à condensation par air et pompes à chaleur air-eau

Luftgekühlte Flüssigkeitskühler und Wärmepumpen

Refrigeratori d'Acqua e Pompe di Calore Raffreddati ad Aria

Enfriadores de Agua y Bomba de Calor Condensadas con Aire

Part number / Code / Code / Codice / Código: **J36756/H**

Supersedes / Annule et remplace / Annulliert und ersetzt / Annulla e sostituisce /

Anula y sustituye: **J36756/G**

Notified Body / Organisme Notifié / Benannte Zertifizierungsstelle /

Organismo Notificato / Organismo Notificado **Nº. 0425**



ISO 9001:2015 certified management system

Table of Contents

1 - FOREWORD

1.1 Introduction.....	2
1.2 Warranty.....	2
1.3 Emergency stop/Normal stop.....	2
1.4 An introduction to this manual.....	2

2 - SAFETY

2.1 Foreword.....	3
2.2 Definitions.....	4
2.3 Access to the unit.....	4
2.4 General precautions.....	4
2.5 Precautions against residual risks.....	4
2.6 Precautions during maintenance operations.....	5
2.7 Safety labels.....	6 & 7
2.8 Safety regulations.....	8 to 10

3 - TRANSPORT, LIFTING AND POSITIONING

3.1 Inspection.....	11
3.2 Lifting.....	11
3.3 Anchoring.....	12
3.4 Storage.....	12

4 - INSTALLATION

4.1 Positioning of the unit.....	13
4.2 Spring Isolator Installation.....	13
4.3 External Water Circuit.....	14 to 22
4.4 Water connections.....	23
4.5 Defrost water drainage (only for HP units).....	23
4.6 Power supply.....	23
4.7 Electrical connections.....	24
4.8 Connecting plate-type evaporator temperature sensors.....	24 to 28

5 - START-UP

5.1 Preliminary check.....	29
5.2 Start-up.....	29
5.3 Checking the operation.....	29
5.4 Delivery to the customer.....	29

6 - CONTROL

6.1 The "Chiller Control" system.....	30
6.2 Display.....	31
6.3 Keyboard.....	31 to 36
6.4 Protection and Safety Equipment.....	37
6.5 HPF version configuration.....	38

7 - PRODUCT DESCRIPTION

7.1 General Information.....	39
7.2 Body and Frame.....	39
7.3 Compressors.....	39
7.4 Evaporators.....	39
7.5 Condensing/evaporating coils.....	39
7.6 Condenser Fans.....	39
7.7 Fans Control.....	39
7.8 Refrigerating Circuit.....	39
7.9 Control Supply Panel.....	39

8 - TECHNICAL DATA

8.1 Pressure drops.....	44
8.2 Technical data.....	45 to 50
8.3 Unit electrical data.....	51 to 60
8.4 Hydraulic Features.....	61 to 76
8.5 Position of shock adsorbers and weight distribution on supports.....	77
8.6 Dimensional Drawings.....	78 to 84
8.7 Service requirements.....	85

9 - MAINTENANCE

9.1 General requirements.....	86
9.2 Planned maintenance.....	86
9.3 Refrigerant charge.....	87
9.4 Compressor.....	87
9.5 Condenser.....	87
9.6 Fans.....	87
9.7 Dehydrating filter.....	87
9.8 Sight glass.....	87
9.9 Electronic expansion valve.....	88
9.10 Evaporator.....	88

10 - TROUBLESHOOTING

11 - SPARE PARTS

11.1 Spare part list.....	90
11.2 Oil for compressors.....	90
11.3 Wiring diagrams.....	90

12 - DISMANTLING, DEMOLITION AND SCRAPPING

12.1 Generalities.....	91
12.2 RAEE Directive.....	91

1 - Foreword

1.1 Introduction

Units, manufactured to state-of-the-art design and implementation standards, ensure top performance, reliability and fitness to any type of air-conditioning systems.

These units are designed for cooling water or glycoled water (and for water heating in heat pump models) and are unfit for any purposes other than those specified in this manual.

This manual includes all the information required for a proper installation of the units, as well as the relevant operating and maintenance instructions.

It is therefore recommended to read this manual carefully before installation or any operation on the machine. The chiller installation and maintenance must be carried out by skilled personnel only (where possible, by one of Authorised Service Centers).

The manufacturer may not be held liable for any damage to people or property caused by improper installation, start-up and/or improper use of the unit and/or failure to implement the procedures and instructions included in this manual.

1.2 Warranty

These units are delivered complete, tested and ready for being operated. Any form of warranty will become null and void in the event that the appliance is modified without manufacturer's preliminary written authorisation.

This warranty shall apply providing that the installation instructions have been complied with (either issued by manufacturer, or deriving from the current practice), and the Form 1 ("Start-up") has been filled-in and mailed to manufacturer (attn. After-Sales Service).

In order for this warranty to be valid, the following conditions shall be met:

- The machine must be operated only by skilled personnel from Authorised After-Sales Service.
- Maintenance must be performed only by skilled personnel - from one of Authorised After-Sales Centers.
- Use only original spare parts.
- Carry out all the planned maintenance provided for by this manual in a timely and proper way.

Failure to comply with any of these conditions will automatically void the warranty.

1.3 Emergency stop / Normal stop

The emergency stop of the unit can be enabled using the master switch on the control panel (move down the lever).





For a normal stop, press the relevant push-buttons.

To restart the appliance, follow the procedure detailed in this manual.

1.4 An introduction to the manual

For safety reasons, it is imperative to follow the instructions given in this manual. In case of any damage caused by non-compliance with these instructions, the warranty will immediately become null and void.

Conventions used throughout the manual:

	The Danger sign recalls your attention to a certain procedure or practice which, if not followed, may result in serious damage to people and property.
	The Warning sign precedes those procedures that, if not followed, may result in serious damage to the appliance.
	The Notes contain important observations.
	The Useful Tips provide valuable information that optimises the efficiency of the appliance.

This manual and its contents, as well as the documentation which accompanies the unit, are and remain the property of manufacturer, which reserves any and all rights thereon. This manual may not be copied, in whole or in part, without manufacturer's written authorization.

2 - Safety

2.1 Foreword

These units must be installed in conformity with the provisions of Machinery Directive 2006/42/EC, Pressure Equipment Directive 2014/68/EU, Electromagnetic Compatibility Directive 2014/30/EU, as well as with other regulations applicable in the country of installation. If these provisions are not complied with, the unit must not be operated.

	<p>The unit must be grounded, and no installation and/or maintenance operations may be carried out before deenergising the electrical panel of the unit.</p>
-----------------------------------------------------------------------------------	--------------------------------------------------------------------------------------------------------------------------------------------------------------

Failure to respect the safety measures mentioned above may result in electrocution hazard and fire in the presence of any short-circuits.

	<p>Inside the heat exchangers, the compressors and the refrigeration lines, this unit contains liquid and gaseous refrigerant under pressure. The release of this refrigerant may be dangerous and cause injuries.</p>
-----------------------------------------------------------------------------------	------------------------------------------------------------------------------------------------------------------------------------------------------------------------------------------------------------------------

	<p>The units are not designed to be operated with natural refrigerants, such as hydrocarbons. Manufacturer may not be held liable for any problems deriving from the replacement of original refrigerant or the introduction of hydrocarbons.</p>
-------------------------------------------------------------------------------------	---------------------------------------------------------------------------------------------------------------------------------------------------------------------------------------------------------------------------------------------------

Units are designed and manufactured according to the requirements of European Standard PED 2014/68/EU (pressure equipment).

- The used refrigerants are included in group II (non-hazardous fluids).
- The maximum working pressure values are mentioned on the unit's data plate.
- Suitable safety devices (pressure switches and safety valves) have been provided, to prevent any anomalous overpressure inside the plant.
- The vents of the safety valves are positioned and oriented in such a way as to reduce the risk of contact with the operator, in the event that the valve is operated. Anyway, the installer will convey the discharge of the valves far from the unit.
- Dedicated guards (removable panels with tools) and danger signs indicate the presence of hot pipes or components (high surface temperature).

	<p>The guards of the fans (only for units provided with air heat exchangers) must be always mounted and must never be removed before de-energising the appliance.</p>
-----------------------------------------------------------------------------------	-----------------------------------------------------------------------------------------------------------------------------------------------------------------------

	<p>It is the User's responsibility to ensure that the unit is fit for the conditions of intended use and that both installation and maintenance are carried out by experienced personnel, capable of respecting all the recommendations provided by this manual.</p> <p>It is important that the unit is adequately supported, as detailed in this manual. Non-compliance with these recommendations may create hazardous situations for the personnel.</p>
-----------------------------------------------------------------------------------	-------------------------------------------------------------------------------------------------------------------------------------------------------------------------------------------------------------------------------------------------------------------------------------------------------------------------------------------------------------------------------------------------------------------------------------------------------------

	<p>The unit must rest on a base which meets the characteristics specified in this manual; a base with inadequate characteristics is likely to become a source of serious injury to the personnel.</p>
-----------------------------------------------------------------------------------	-------------------------------------------------------------------------------------------------------------------------------------------------------------------------------------------------------

	<p>The unit has not been design to withstand loads and/or stress that may be transmitted by adjacent units, piping and/or structures.</p> <p>Each external load or stress transmitted to the unit may break or cause breakdowns in the unit's structure, as well as serious dangers to people. In these cases, any form of warranty will automatically become null and void.</p>
-------------------------------------------------------------------------------------	----------------------------------------------------------------------------------------------------------------------------------------------------------------------------------------------------------------------------------------------------------------------------------------------------------------------------------------------------------------------------------

	<p>The packaging material must not be disposed of in the surrounding environment or burnt.</p>
-------------------------------------------------------------------------------------	------------------------------------------------------------------------------------------------

2 - Safety (continued)

2.2 Definitions

OWNER: means the legal representative of the company, body or individual who owns the plant where unit has been installed; he/she has the responsibility of making sure that all the safety regulations specified in this manual are complied with, along with the national laws in force.

INSTALLER: means the legal representative of the company who has been given by the owner the job of positioning and performing the hydraulic, electric and other connections of unit to the plant: he/she is responsible for handling and properly installing the appliance, as specified in this manual and according to the national regulations in force.

OPERATOR: means a person authorised by the owner to do on unit all the regulation and control operations expressly described in this manual, that must be strictly complied with, without exceeding the scope of the tasks entrusted to him.

ENGINEER: means a person authorised directly by manufacturer or, in all EC countries, excluding Italy, under his full responsibility, by the distributor of product, to perform any routine and extraordinary maintenance operations, as well as any regulation, control, servicing operations and the replacement of pieces, as may be necessary during the life of the unit.

2.3 Access to the unit

The unit must be placed in an area which can be accessed also by OPERATORS and ENGINEERS; otherwise the unit must be surrounded by a fence at not less than 2 meters from the external surface of the machine.

OPERATORS and ENGINEERS must enter the fenced area only after wearing suitable clothing (safety shoes, gloves, helmet etc.). The INSTALLER personnel or any other visitor must always be accompanied by an OPERATOR.

For no reason shall any unauthorised personnel be left alone in contact with the unit.

2.4 General precautions

The OPERATOR must simply use the controls of the unit; he must not open any panel, other than the one providing access to the control module.

The INSTALLER must simply work on the connections between plant and machine; he must not open any panels of the machine and he must not enable any control.

When you approach or work on the unit, follow the precautions listed below:

- do not wear loose clothing or jewellery or any other accessory that may be caught in moving parts
- wear suitable personal protective equipment (gloves, goggles etc.) when you have to work in the presence of free flames (welding operations) or with compressed air
- if the unit is placed in a closed room, wear ear protection devices
- cut off connecting pipes, drain them in order to balance the pressure to the atmospheric value before disconnecting them,

disassemble connections, filters, joints or other line items

- do not use your hands to check for any pressure drops
- use tools in a good state of repair; be sure to have understood the instructions before using them
- be sure to have removed all tools, electrical cables and any other objects before closing and starting the unit again

2.5 Precautions against residual risks

Prevention of residual risks caused by the control system

- be sure to have perfectly understood the operating instructions before carrying out any operation on the control panel
- when you have to work on the control panel, keep always the operating instructions within reach
- start the unit only after you have checked its perfect connection to the plant
- promptly inform the ENGINEER about any alarm involving the unit
- do not reset manual restoration alarms unless you have identified and removed their cause

Prevention of residual mechanical risks

- install the unit according to the instructions provided in this manual
- carry out all the periodical maintenance operations prescribed by this manual
- wear a protective helmet before accessing the interior of the unit
- before opening any panelling of the machine, make sure that it is secured to it by hinges
- do not touch air condensation coils without wearing protective gloves
- do not remove the guards from moving elements while the unit is running
- check the correct position of the moving elements' guards before restarting the unit

Prevention of residual electrical risks

- connect the unit to the mains according to the instructions provided in this manual
- periodically carry out all the maintenance operations specified by this manual
- disconnect the unit from the mains by the external disconnecting switch before opening the electrical board
- check the proper grounding of the unit before start-up
- check all the electrical connections, the connecting cables, and in particular the insulation; replace worn or damaged cables

2 - Safety (continued)

- periodically check the board's internal wiring
- do not use cables having an inadequate section or flying connections, even for limited periods of time or in an emergency

Prevention of other residual risks

- make sure that the connections to the unit conform to the instructions provided in this manual and on the unit's panelling
- if you have to disassemble a piece, make sure that it has been properly mounted again before restarting the unit
- do not touch the delivery pipes from the compressor, the compressor and any other piping or component inside the machine before wearing protective gloves
- keep a fire extinguisher for electrical appliances near the machine
- Wear proper protections near the safety valves. Each valve conveying through piping may change the real intervention value
- remove and leak of fluid inside and outside the unit
- collect the waste liquids and dry any oil spillage
- periodically clean the compressor compartment, to remove any fouling
- do not store flammable liquids near the unit
- do not disperse the refrigerant and the lubricating oil into the environment
- weld only empty pipes; do not approach flames or other sources of heat to refrigerant pipes
- do not bend/hit pipes containing fluids under pressure

2.6 Precautions during maintenance operations

Maintenance operations can be carried out by authorised technicians only.

Before performing any maintenance operations:

- disconnect the unit from the mains with the external disconnecting switch

- place a warning sign "do not turn on - maintenance in progress" on the external disconnecting switch
- make sure that on-off remote controls are inhibited
- wear suitable personal protective equipment (helmet, safety gloves, goggles and shoes etc.)

To carry out any measurements or checks which require the activation of the machine:

- work with the electrical board open only for the necessary time
- close the electrical board as soon as the measurement or check has been completed
- for outdoor units, do not carry out any operations in the presence of dangerous climatic conditions (rain, snow, mist etc.)

The following precautions must be always adopted:

- do not scatter the fluids of the refrigeration circuit in the surrounding environment
- when replacing an eprom or electronic cards, use always suitable devices (extractor, antistatic bracelet, etc.)
- to replace a compressor, the evaporator, the condensing coils or any other weighty element, make sure that the lifting equipment is consistent with the weight to be lifted
- in air units with independent compressor compartment, do not access the fan compartment unless you have disconnected the machine by the disconnecting switch on the board and you have placed a warning sign "do not turn on - maintenance in progress"
- contact manufacturer for any modifications to the refrigeration, hydraulic or wiring diagram of the unit, as well as to its control logics
- contact manufacturer if it is necessary to perform very difficult disassembly and assembly operations
- use only original spare parts purchased directly from manufacturer or the official retailers of the companies on the recommended spare parts list
- contact manufacturer if it is necessary to handle the unit one year after its positioning on site or if you wish to dismantle it.

2 - Safety (continued)

2.7 Safety labels

Identification of the refrigerant - External door



Identification of the unit Outside, on the right-hand front column

CODICE PRODOTTO NEUTRO PRODUCT CODE	
EBC CE	
MODELLO MODEL	
MO.NO	
MATRICOLA SERIAL NO.	
ANNO DI COSTRUZIONE Manuf. Year	
REFR. <input type="checkbox"/> GWP	CIRCUIT CHARGE (kg) (CO ₂ eq)
PS (LATO ALTA / LATO BASSA) PS (HIGH / LOW SIDE) bar	
TS (ALTA / BASSA) TS (HIGH / LOW) °C	
ALIM. POTENZA M/RN SUPPLY V / PH / Hz	
CORRENTE DI SPUNTO I _{RA} (max) A	
CORRENTE A PIENO CARICO I _{FLA} (max) A	
POTENZA ASSORBITA POWER INPUT (max) Kw	
PRESS. MAX ESERCIZIO ACQUA MAX WATER OPERATING PRESSURE bar	
MASSA MASS Kg	
SYSTEMAIR S.r.l. Via XXV Aprile 29 20825 BARLASSINA MB ITALIA MADE IN ITALY COD.NO: P35952	
MODELLO: MODEL	
MATRICOLA: SERIAL NO.	
CODICE: PRODUCT CODE	ANNO DI COSTRUZIONE Manuf. Year
MODELLO: MODEL	
MATRICOLA: SERIAL NO.	
CODICE: PRODUCT CODE	ANNO DI COSTRUZIONE Manuf. Year
MODELLO: MODEL	
MATRICOLA: SERIAL NO.	
CODICE: PRODUCT CODE	ANNO DI COSTRUZIONE Manuf. Year

Pump operation - Outside, on the right-hand front column

**LAS BOMBAS MONTADAS EN ESTA UNIDAD NO PUEDEN TRABAJAR SIN AGUA.
DIE PUMPEN DIESES GERÄTES DÜRFEN NICHT OHNE WASSER BETRIEBEN WERDEN
THE PUMPS ON BOARD OF THIS UNIT CAN NOT WORK WITHOUT WATER.
LES POMPES A BORD DE CETTE UNITÉ NE PEUVENT PAS FONCTIONNER SANS EAU.
LE POMPE A BORDO DI QUESTA UNITÀ NON POSSONO FUNZIONARE SENZA ACQUA**

Circuit drain - Outside, on the right-hand front column



ATTENTION! Don't leave the unit with water inside hydraulic circuit during winter or when it is in stand by.
ATTENZIONE! Non lasciare l'unità con acqua nel circuito idraulico durante l'inverno o quando non è funzionante.
ATTENTION! Ne laissez pas l'unité avec de l'eau dans le circuit hydraulique pendant l'hiver ou quand elle ne travaille pas.
WARNUNG! Entfernen Sie das Wasser aus dem hydraulischen Kreislauf bei einem Defekt und im Winter.
¡ATENCIÓN! No deje el agua en el circuito hidráulico durante el invierno o cuando no está trabajando.

Instruction for the lifting

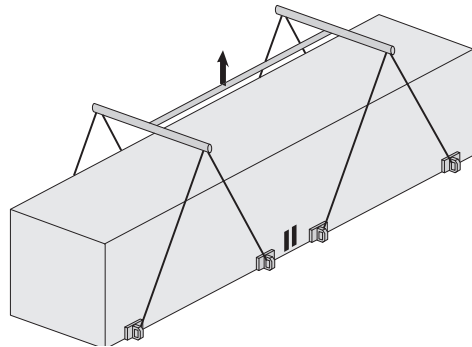
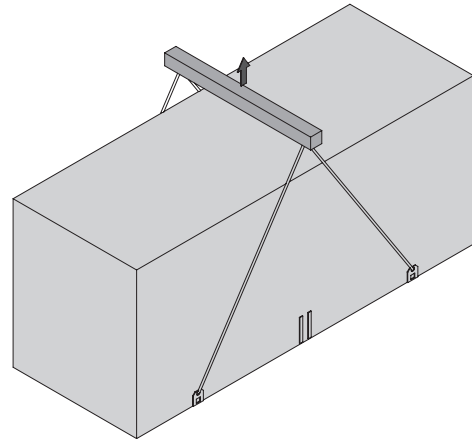

Sequence phase control on the electrical board

ATTENZIONE
QUESTO COMPRESSORE RICHIEDE UN CORRETTO SENSO DI ROTAZIONE
RISPETTARE LA CORRETTA SEQUENZA DELLE FASI
CAUTION
THIS COMPRESSOR REQUIRES PROPER DIRECTION OF ROTATION
CHECK PROPER ELECTRICAL PHASING
ACHTUNG
KOMPRESSOREN BENÖTIGEN KORREKTES DREHFELD.
ELEKTRISCHE ANSCHLÜSSE AUF DREHFELD ÜBERPRÜFEN
ATTENTION
CES COMPRESSEURS NECESSITENT UN BON SENSE DE ROTATION
VERIFIER LE CABLAGE DES PHASES
ATENCIÓN
ESTOS COMPRESORES DEBEN FUNCIONAR EN EL SENTIDO DE ROTACIÓN CORRECTO
COMPROBAR EL CABLEADO DE LAS FASES

Gravity centre - Base

**TENERE SU QUESTA LINEA
GANCIO DI SOLLEVAMENTO**

**KEEP LIFT HOOK
ON THIS LINE**

Instruction for the lifting



2 - Safety (continued)

Electrical warning Adjacent to the master switch

	ATTENZIONE !	ATTENTION !
	Prima di aprire togliere tensione	Enlever l'alimentation électrique avant d'ouvrir
ACHTUNG !	CAUTION !	ATENCIÓN !
Vor Öffnen des Gehäuses Hauptschalter betätigen	Disconnect electrical supply before opening	Cortar la corriente antes de abrir el aparato

Start-up warning - Outside the door of the electrical board

ATTENZIONE

INSERIRE LE RESISTENZE DI RISCALDAMENTO OLIO ALMENO 12 ORE PRIMA DI OGNI AVVIAMENTO (SE PREVISTE) PRIMA DELLA MESSA IN TENSIONE ASSICURARSI CHE LE VITI DEI CIRCUITI ELETTRICI SIANO SERRATE COMPLETAMENTE

WARNING

ENERGIZE THE CRANCKCASE HEATER FOR AT LEAST 12 HOURS BEFORE EACH STARTING (IF FITTED) BEFORE TIGHTENING-UP, TO TIGHTEN ALL TERMINAL SCREWS ESPECIALLY THOSE IN MAIN CIRCUIT

WARNUNG

OLSUMPFFHEIZUNG (FALLS VORHANDEN) 12 STUNDEN VOR DEM START EINSCHALTEN VOR INBETRIEBNAHME ALLE SCHRAUBENVERBINDUNGEN NACHZIEHEN, BESONDERS DIE ELEKTRISCHEN ANSCHLUSSE

ATTENTION

ALIMENTER ELECTRIQUEMENT LA RESISTANCE DE CARTER AU MOINS 12 HEURES AVANT CHAQUE DEMARRAGE (SI MONTE SUR LE PRODUIT) AVANT DE DEMARRER LA MACHINE, VERIFIER LE SERRAGE DE TOUTES LES BORNES A VIS, SPECIALEMENT DANS LE BOITIER ELECTRIQUE

ATENCIÓN

ATENCIÓN ALIMENTAR ELÉCTRICAMENTE LA RESISTENCIA DE CARTER AL MENOS 12 HORAS ANTES DE CADA PUESTA EN MARCHA (SI ESTA EQUIPADA EN LA UNIDAD) ANTES DE LA PUESTA EN MARCHA, COMPROBAR QUE LOS BORNES ESTAN BIEN APRETADOS, ESPECIALMENTE EN EL CUADRO ELÉCTRICO

035B00057-000

MADE IN ITALY

Final Test Certificate - Inside the external door

QUALITY CHECK PROOF		
MODEL/TYPE	SERIAL NUMBER/PRODUCT KEY	F. NUMBER CODE
MODELLO/TIPO	N° DI SERIE/LOTTO DI PRODUZIONE	CODICE
		MANUFACTURED YEAR
		ANNO DI COSTRUZIONE
NUMBER	DESCRIPTION OF INSPECTION	INSPECTOR
CHECK		REFERENCE
NUMERO	DESCRIZIONE DEI TEST DI CONTROLLO	TIMBRIO
CONTROLLI		OPERATORE
01	PRELIMINARY PROOF PRESSURE TEST AND LEAK TEST WITH ULTIM LINE HYDROGEN AT MAXIMUM 30 BAR; REFRIGERANT SIDE IN COMPLIANCE WITH TEST SPECIFICATION - MARK WITH PENS PROVA PRELIMINARE DI PRESSIONE E TENUTA CIRCUITO CON ELIO E ACQUA AD ALTESSA DI 30 BAR (LATO REFRIGERANTE) IN ACCORDO ALLA SPECIFICA DI COLLAUDO - SEGNARE CON PENNARELLO SAFETY TEST (AN ADDITIONAL LEAK TEST WITH HELIUM AND HYDROGEN AT 2,5 BAR (WATER SIDE) - MARK WITH PENS EFFETTUARE UNA PROVA PRELIMINARE DI TENUTA CON ELIO E ACQUA A 30 BAR (LATO ACQUA) - SEGNARE CON PENNARELLO	
02	VACUUM TEST CARRIED OUT VUOTO ESEGUITO	
03	REFRIGERANT CHARGE CARICA REFRIGERANTE	
04	CHECK WIRING CABLE CONNECTION VERIFICA CARABAGGIO ELETTRICO	
05	SAFETY TEST (CONTINUITY, INSULATION, DIELECTRICAL STRENGTH) PROVA DI SICUREZZA (CONTINUITA', ISOLAMENTO, RESISTIVITA')	
06	RUNNING TEST WITH SAFETY DEVICES COLLAUDO FUNZIONALE COMPLETO CON INTERVENTO SICUREZZA E FRENO	
07	LEAK TEST ON REFRIGERANT CIRCUIT DURING RUNNING CONDITION - MARK WITH PENS VERIFICA TENUTA CIRCUITO REFRIGERANTE DURANTE IL FUNZIONAMENTO - SEGNARE CON PENNARELLO	
08	FINAL LEAK TEST ON REFRIGERANT CIRCUIT AFTER RUNNING - MARK WITH PENS VERIFICA FINALE TENUTA CIRCUITO REFRIGERANTE DOPO IL COLLAUDO FUNZIONALE - SEGNARE CON PENNARELLO	
09	CHECK ASSEMBLY PARTS VERIFICA ASSEMBLAGGIO PARTI	
10	CHECK AND ENTER ACCESSORIES OR SUPPLY LOSS CONTROLO ACCESSORI/MONTATI E/O FORNITI A BORDO UNITA'	
11	CHECK CROSS SUPPLY (E, I, M, START UP FORM, WIRING DIAGRAM, H, I, E) VERIFICA DOCUMENTI FORNITI CON L'UNITA'	
12	CHECK PROTECTIVE COVERING VERIFICA TARGHETTE	
13	THEORETICAL CHECK AND CLEANING CONTROLO E PULIZIA	
14	CHECK TEST SHEET AND CHECK LIST FILLED UP CONTROLO COMPILAZIONE SCHEDA DI COLLAUDO E CHECK LIST	

Grounding connection on the electrical board, adjacent to the connection

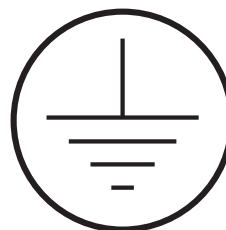

Read the instruction on the electrical board



Fan Danger

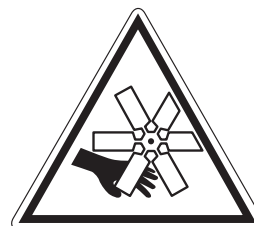

Fitting identification - Adjacent to fittings

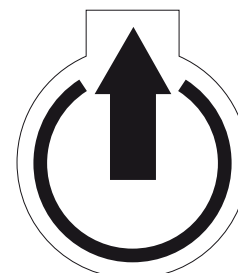
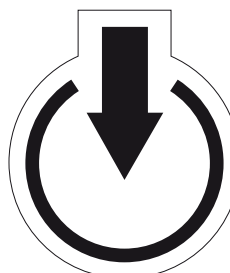

2 - Safety (continued)

2.8 Safety regulations

REFRIGERANT DATA	SAFETY DATA: R410A
Toxicity	Low
Contact with skin	<p>If sprayed, the refrigerant is likely to cause frost burns. If absorbed by the skin, the danger is very limited; it may cause a slight irritation, and the liquid is degreasing. Unfreeze the affected skin with water. Remove the contaminated clothes with great care - in the presence of frost burns, the clothes may stick to the skin. Wash with plenty of warm water the affected skin.</p> <p>In the presence of symptoms such as irritation or blisters, obtain medical attention.</p>
Contact with eyes	<p>Vapours do not cause harmful effects. The spraying of refrigerant may cause frost burns. Wash immediately with a proper solution or with tap water for at least 10 minutes, and then obtain medical attention.</p>
Ingestion	<p>Very unlikely - should something happen, it will cause frost burns.</p> <p>Do not induce vomiting. Only if the patient is conscious, wash out mouth with water and give some 250 ml of water to drink. Then, obtain medical attention.</p>
Inhalation	<p>R410A: remarkable concentrations in the air may have an anaesthetic effect, up to fainting.</p> <p>The exposure to considerable amounts may cause irregular heartbeat, up to the sudden death of the patient. Very high concentrations may result in the risk of asphyxia, due to the reduction in the oxygen percentage in the atmosphere. Remove the patient to fresh air and keep warm and at rest.</p> <p>If necessary, give oxygen. In case of breathing difficulties or arrest, proceed with artificial respiration.</p> <p>In case of cardiac arrest, proceed with cardiac massage. Then, obtain medical attention.</p>
Recommendations	<p>Semiotics or support therapy is recommended. Cardiac sensitisation has been observed that, in the presence of circulating catecholamines such as adrenalin, may cause cardiac arrhythmia and accordingly, in case of exposure to high concentrations, cardiac arrest.</p>
Prolonged exposure	<p>R410A: a study on the effects of exposure to 50,000 ppm during the whole life of rats has identified the development of benign testicle tumour.</p> <p>This situation should therefore be negligible for personnel exposed to concentrations equal to or lower than professional levels.</p>
Professional levels	R410A: Recommended threshold: 1000 ppm v/v - 8 hours TWA.
Stability	R410A: Not specified
Conditions to avoid	Do not use in the presence of flames, burning surfaces and excess humidity.
Hazardous reactions	<p>May react with sodium, potassium, barium and other alkaline metals.</p> <p>Incompatible substances: magnesium and alloys with magnesium concentrations > 2%.</p>
Hazardous decomposition products	R410A: Halogen acids produced by thermal decomposition and hydrolysis.

2 - Safety (continued)

2.8 Safety regulations (continued)

REFRIGERANT DATA	SAFETY DATA: R410A
General precautions	Do not inhale concentrated vapours. Their concentration in the atmosphere should not exceed the minimum preset values and should be maintained below the professional threshold. Being more weighty than the air, the vapour concentrates on the bottom, in narrow areas. Therefore, the exhaust system must work at low level.
Respiratory system protection	If you are in doubt about the concentration in the atmosphere, it is recommended to wear a respirator approved by an accident-prevention Authority, of the independent or oxygen type.
Storage	Cylinders must be stored in a dry and fresh place, free from any fire hazard, far from direct sunlight or other sources of heat, radiators etc. Keep a temperature below 50 °C.
Protective clothing	Wear overalls, protective gloves and goggles or a mask.
Accidental release measures	It is important to wear protective clothing and a respirator. Stop the source of the leak, if you can do this without danger. Negligible leaks can be left evaporating under the sun, providing that the room is well ventilated. Considerable leaks: ventilate the room. Reduce the leak with sand, earth or other absorbing substances. Make sure that the liquid does not channelled into gutters, sewers or pits where the vapours are likely to create a stuffy atmosphere.
Disposal	The best method is recovery and recycling. If this method is not practicable, dispose according to an approved procedure, that shall ensure the absorption and neutralization of acids and toxic agents.
Fire fighting information	R410A: Not flammable in the atmosphere.
Cylinders	The cylinders, if exposed to fire, shall be cooled by water jets; otherwise, if heated, they may explode.
Protective fire fighting equipment	In case of fire, wear an independent respirator and protective clothing.

2 - Safety (continued)

2.8 Safety regulations (continued)

LUBRICANT OIL DATA	SAFETY DATA: POE/PVE OIL
Classification	Not harmful.
Contact with skin	May cause slight irritation. Does not require first aid measures. It is recommended to follow usual personal hygiene measures, including washing the exposed skin with soap and water several times a day. It is also recommended to wash your overalls at least once a week.
Contact with eyes	Wash thoroughly with a suitable solution or tap water.
Ingestion	Seek medical advice immediately.
Inhalation	Seek medical advice immediately.
Conditions to avoid	Strong oxidising substances, caustic or acid solutions, excess heat. May corrode some types of paint or rubber.
Protection of the respiratory system	Use in well ventilated rooms.
Protective clothing	Always wear protective goggles or a mask. Wearing protective gloves is not mandatory, but is recommended in case of prolonged exposure to refrigerant oil.
Accidental release measures	It is important to wear protective clothing and, especially, goggles. Stop the source of the leak. Reduce the leak with absorbing substances (sand, sawdust or any other absorbing material available on the market).
Disposal	The refrigerant oil and its waste will be disposed of in an approved incinerator, in conformity with the provisions and the local regulations applicable to oil waste.
Fire fighting information	In the presence of hot liquid or flames, use dry powder, carbon dioxide or foam. If the leak is not burning, use a water jet to remove any vapours and to protect the personnel responsible for stopping the leak.
Cylinders	The cylinders exposed to a fire will be cooled with water jets in case of fire.
Fire fighting protective equipment	In case of fire, wear an independent respirator.

3 - Transport, Lifting and Positioning

Refrigerators are supplied assembled (apart from standard antivibrating rubber supports, that will be installed on site). The equipment are full of refrigerant and oil, in the quantity required for a proper operation.

3.1 Inspection

When the unit is delivered, it is recommended to check it carefully and to identify any damage occurred during transportation. The goods are shipped ex-factory, at the buyer's risk. Check that the delivery includes all the components listed in the order.

In case of damage, note it down on the carrier's delivery note and issue a claim according to the instructions provided in the delivery note.

In the presence of any serious damage, that does not affect the surface only, it is recommended to inform manufacturer immediately.

Please note that manufacturer may not be held liable for any damage to the equipment during transportation, even though the carrier has been appointed by the factory.

3.2 Lifting

The unit must be lifted by using the hooks inserted into the relevant eyebolts (see the figure).

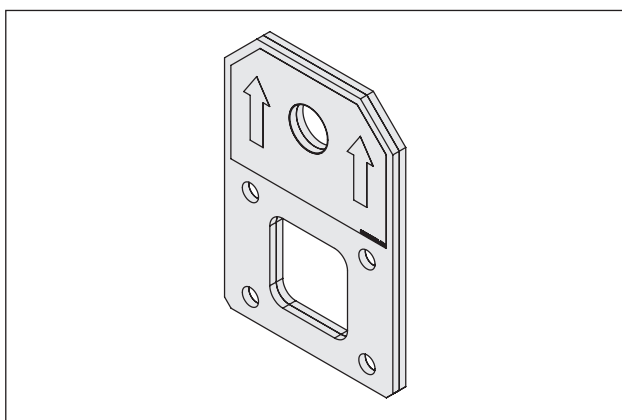

It is recommended to use a spacer to prevent cables from damaging the unit (see the figure).

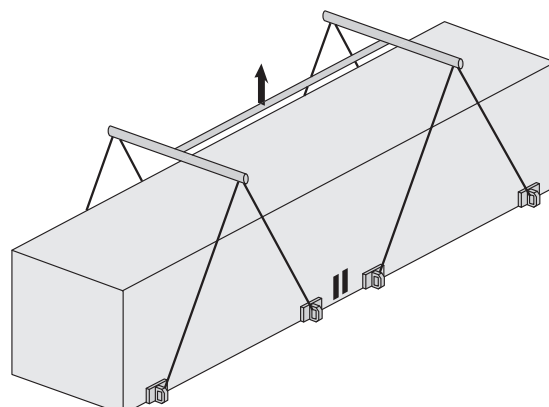
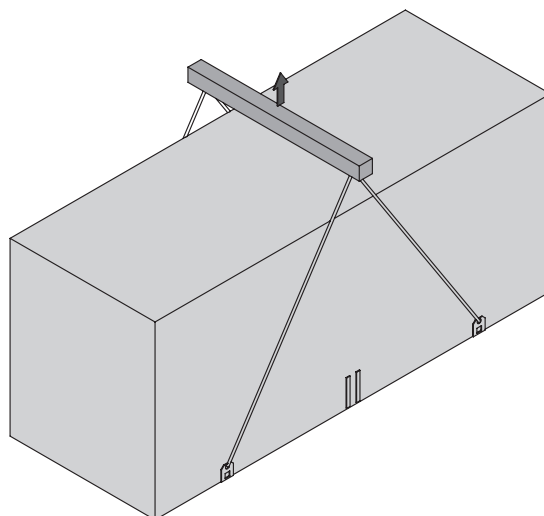

Before positioning the unit, make sure that the place of installation is appropriate and sturdy enough to hold the weight and to withstand the stress caused by the operation of the whole assembly.



Do not displace the unit on rollers, and do not lift it with a lift truck.

Unit must be lifted carefully.

To lift unit slowly and regularly.

To lift and displace the unit:

- Insert and secure eyebolts into the holes marked on the frame.
- Insert spacer between cables.
- Place the spacer in line with the center of gravity of the unit.
- The cables must be long enough to form, if tensioned, an angle of at least 45° with respect to the horizontal plane.



For lifting operations, use only tools and material fit for this purpose, in accordance with accident-prevention regulations.

3 - Transport, Lifting and Positioning (continued)



During the lifting and handling of the unit, be careful not to damage the finned pack of the coils positioned on the sides of the unit.

The sides of the unit must be protected by cardboard or plywood sheets.



It is recommended not to remove the protective plastic envelope, that should prevent scraps from penetrating into the appliance and any damage to the surfaces, until the unit is ready for operation.



The lifting eyebolts protrude from the base of the unit; it is therefore recommended to remove them once the unit has been lifted and positioned, if in your opinion they are likely to become a source of hazard and injury.

The eyebolts must be mounted on the unit whenever it shall be displaced and then lifted again.

3.3 Anchoring

It is not essential to secure the unit to the foundations, unless in areas where there is a serious risk of earthquake, or if the appliance is installed on the top of a steel frame.

3.4 Storage

When the unit is to be stored before installation, adopt a few precautions to prevent any damage or risk of corrosion or wear:

- plug or seal every single opening, such as water fittings
- do not store the appliance in a room where the temperature exceeds 50 °C for the units using R410A and, if possible, do not expose to direct sunlight
- minimum storage temperature is -25 °C
- it is recommended to store the unit in a roof where traffic is minimized, to prevent the risk of accidental damage
- the unit must not be washed with a steam jet
- take away and leave to the site manager all the keys providing access to the control board

Finally, it is recommended to carry out visual inspections at regular intervals.

4 - Installation

4.1 Positioning of the unit



Before installing the unit, make sure that the structure of the building and/or the supporting surface can withstand the weight of the appliance. The weights of the units are listed in Chapter 8 of this manual.

These units have been designed for outdoor installation on a solid surface. Standard accessories include antivibrating rubber supports, that must be positioned under the base.

When the unit is to be installed on the ground, it is necessary to provide a concrete base, to ensure a uniform distribution of the weights.

As a general rule, no special sub-bases are required. However, if the unit is to be installed on the top of inhabited rooms, it is advisable to rest it on spring shock absorbers (optional), that will minimise the transmission of any vibration to the structures.

To choose the place of installation of the unit, bear in mind that:

- the longitudinal axis of the unit must be parallel to the direction of prevailing winds, so as to ensure a uniform distribution of the air on finned exchangers
- the unit must not be installed near boilers' vent pipes
- the unit must not be installed leeward with respect to sources of air contaminated by greases, such as, for example, the outlets to kitchen exhaust hoods into the atmosphere. Otherwise, the grease is likely to deposit on the fins of the refrigerant /air exchangers, and would fix every type of atmospheric impurity, resulting in the quick clogging of the exchangers
- the unit must not be installed in areas subject to considerable snow falling
- the unit must not be installed in areas subject to flooding, under gutters etc.
- the unit must not be installed in air shafts, narrow courts or other small places, where the noise may be reflected by the walls or the air ejected by fans may short-circuit itself on refrigerant/air heat exchangers or condenser
- the place of installation must be have all the necessary spaces for air circulation and maintenance operations (see Chapter 8).

4.2 Spring Isolator Installation

- Prepare the base, that must be flat and plane.
- Lift the appliance and insert shock absorbers as follows:

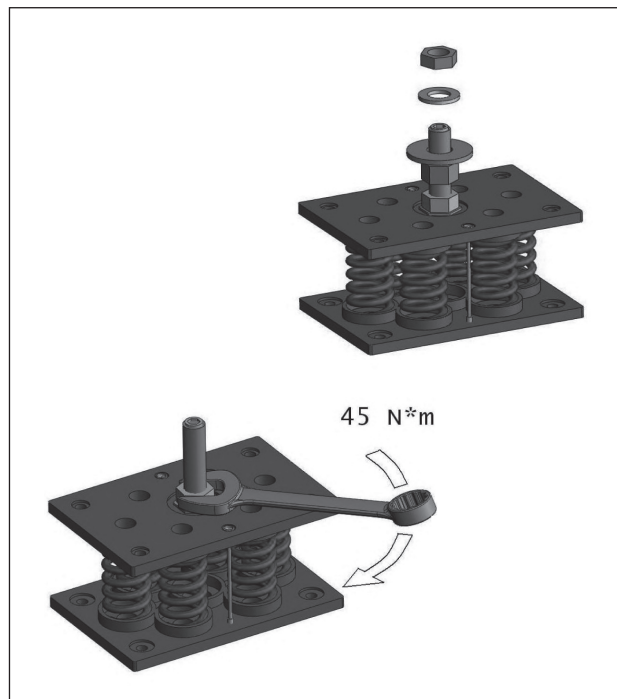

- 1) Proceed to assemble the jack components. Fit the jack in the threaded housing on the upper plate of the antivibration mount.

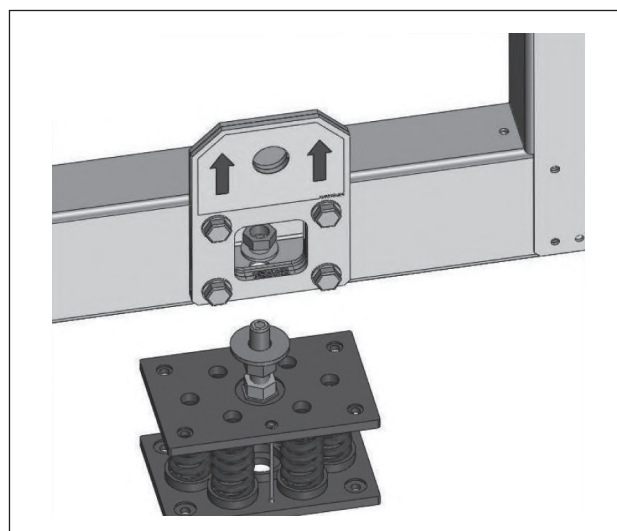

- 2) Fit the jack mounted on the antivibration mount in the hole in the machine base.

4 - Installation (continued)

4.3 External Water Circuit

The flow switch and the filter water, although not included in the supply, must always be fitted such as plant components. Their installation is mandatory for warranty.



The external water circuit shall guarantee a constant water flow rate through the circulating refrigerant/water heat exchanger (evaporator) under steady operating conditions and in case of a load variation.

The circuit shall be composed by the following elements:

- A circulation pump which can ensure the necessary flow rate and head.
- The total content of the primary water circuit shall never be lower than 3 l/kW in terms of refrigerating capacity. If the total water volume in the primary circuit should be unable to reach such a value, an additional heat-insulated storage tank should be installed. This tank is intended to avoid any repetitive start of the compressor.
- A membrane expansion tank complete with a safety valve and a drain which shall be visible.



The expansion tank shall be dimensioned in such a way that it can absorb a 2% expansion of the total volume of the water in the plant (exchanger, pipelines, uses and storage tank, if available).

The expansion tank shall never be insulated when the circulating fluid is not flowing through it.

A water flow switch is mounted as a standard. It will stop the unit whenever a flow rate problem occurs.

In addition:

- Install on/off valves (accessory) on the lines at the inlet and outlet of the manifolds of the exchangers (evaporator).
- Arrange a by-pass complete with an on/off valve between the manifolds of the heat exchangers.
- Arrange air vent valves at the high points of the water lines.
- Arrange drain points complete with plugs, clocks, etc. in the proximity of the low points of the water lines.
- Insulate the water lines to prevent the heat from blowing back into the unit.

RECOMMENDED WATER COMPOSITION

PH	7,5 - 9	
Electrical conductivity	10 - 500	μS/cm
Total hardness	4,5 - 8,5	dH
Temperature	< 60	[°C]
Alkalinity (HCO ₃ ⁻)	70-300	ppm
Alkalinity / Sulphates (HCO ₃ ⁻ / SO ₄ ²⁻)	> 1	ppm
Sulphates (SO ₄ ²⁻)	< 70	ppm
Chlorides (Cl.)	< 50	ppm
Free Chlorine	< 0,5	ppm
Phosphates (PO ₄ ³⁻)	< 2	ppm
Ammonia (NH ₃)	< 0,5	ppm
Ammonium Ion (NH ₄ ⁺)	< 2	ppm
Manganese Ion (Mn ²⁺)	< 0,05	ppm
Free Carbon Dioxide (CO ₂)	< 5	ppm
Hydrogen Sulfide (H ₂ S)	< 0,05	ppm
Oxygen Content	< 0,1	ppm
Nitrates (NO ₃ ⁻)	< 100	ppm
Manganese (Mn)	< 0,1	ppm
Iron (Fe)	< 0,2	ppm
Aluminium (Al)	< 0,2	ppm

Caution

If the water circuit is to be drained for a time exceeding one month, the circuit must be fully charged with nitrogen to prevent any risk of corrosion by differential venting

4 - Installation (continued)

Hydraulic Circuit Diagram - Basic Unit 400-670 AIR EVO

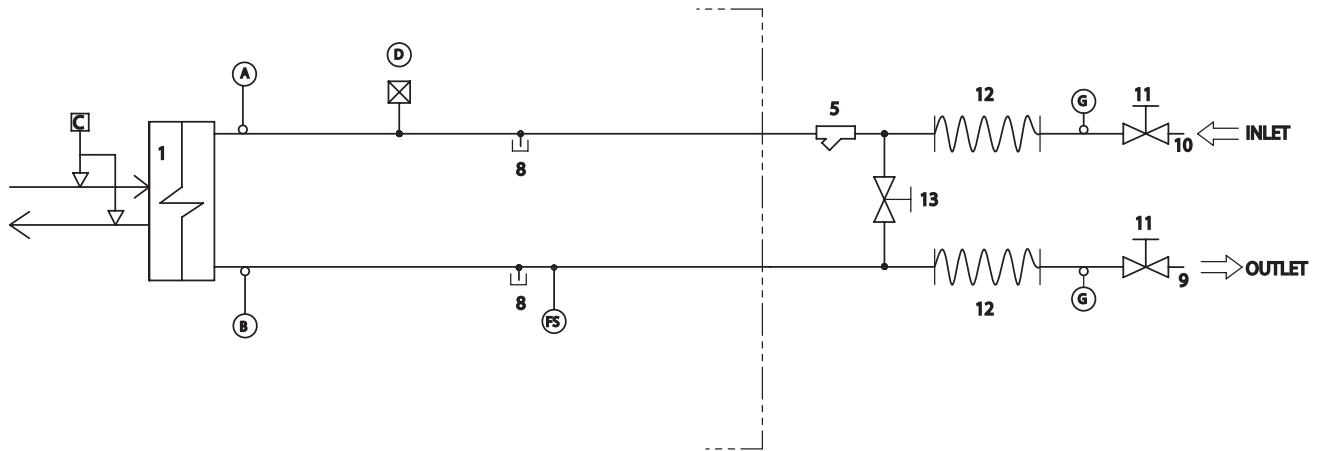

COMPONENTS	
1	Plate heat exchanger
2	Pump
3	Draining valve
4	Water buffer tank
5	Water filter
6	Non-return valve
7	Pressure expansion tank
8	Pressure point/drainage
9	Water outlet
10	Water inlet
11	Globe valve
12	Flexible pipes
13	By pass valve

SAFETY/CONTROL DEVICES	
A	Inlet water temperature sensor
B	Outlet water temperature sensor
C	Water differential pressure switch
D	Vent valve
E	Water safety valve.....(6Bar)
FS	Flow switch
G	Thermometer
----	Unit side
O	Probes

4 - Installation (continued)

Hydraulic Circuit Diagram - Basic Unit 750-900 AIR EVO

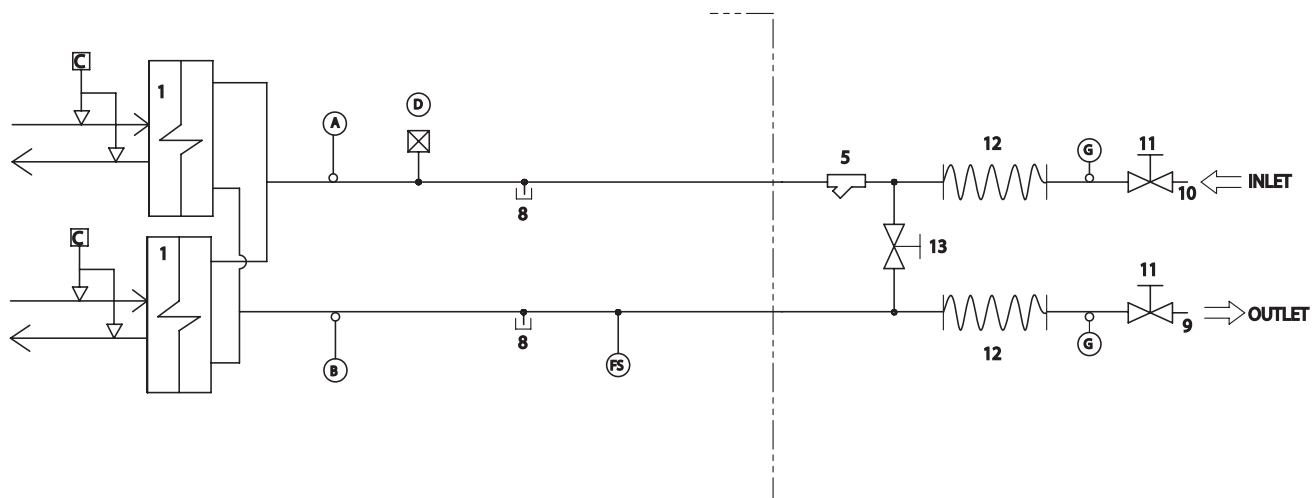

COMPONENTS	
1	Plate heat exchanger
2	Pump
3	Draining valve
4	Water buffer tank
5	Water filter
6	Non-return valve
7	Pressure expansion tank
8	Pressure point/drainage
9	Water outlet
10	Water inlet
11	Globe valve
12	Flexible pipes
13	By pass valve

SAFETY/CONTROL DEVICES	
A	Inlet water temperature sensor
B	Outlet water temperature sensor
C	Water differential pressure switch
D	Vent valve
E	Water safety valve.....(6Bar)
FS	Flow switch
G	Thermometer
----	Unit side
O	Probes

4 - Installation (continued)

Hydraulic Circuit Diagram - 1P Unit 400-670 AIR EVO

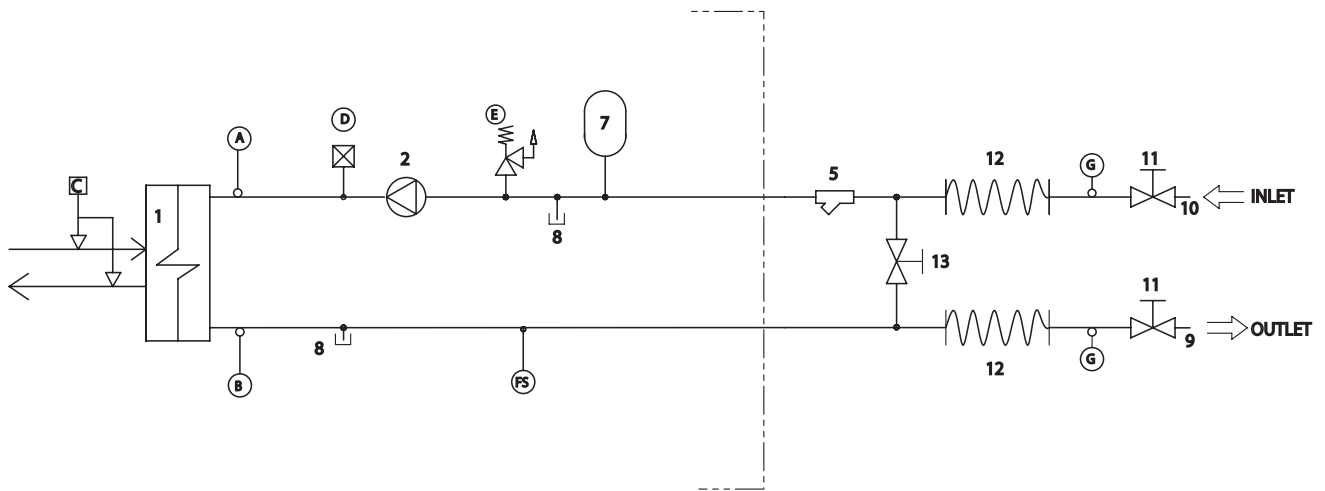

COMPONENTS	
1	Plate heat exchanger
2	Pump
3	Draining valve
4	Water buffer tank
5	Water filter
6	Non-return valve
7	Pressure expansion tank
8	Pressure point/drainage
9	Water outlet
10	Water inlet
11	Globe valve
12	Flexible pipes
13	By pass valve

SAFETY/CONTROL DEVICES	
A	Inlet water temperature sensor
B	Outlet water temperature sensor
C	Water differential pressure switch
D	Vent valve
E	Water safety valve.....(6Bar)
FS	Flow switch
G	Thermometer
----	Unit side
O	Probes

4 - Installation (continued)

Hydraulic Circuit Diagram - 2P Unit 400-670 AIR EVO

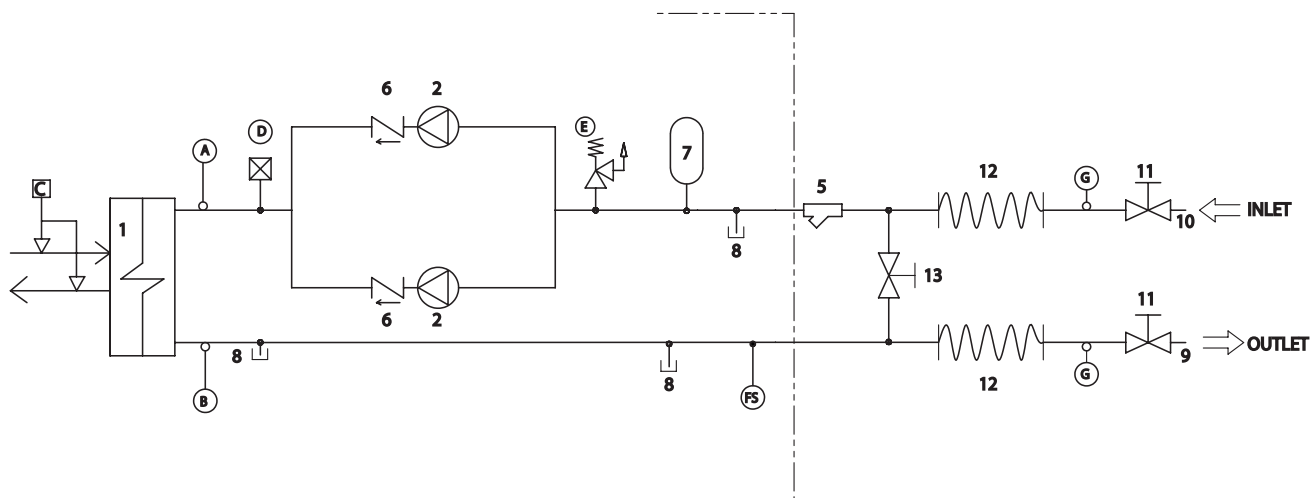

COMPONENTS	
1	Plate heat exchanger
2	Pump
3	Draining valve
4	Water buffer tank
5	Water filter
6	Non-return valve
7	Pressure expansion tank
8	Pressure point/drainage
9	Water outlet
10	Water inlet
11	Globe valve
12	Flexible pipes
13	By pass valve

SAFETY/CONTROL DEVICES	
A	Inlet water temperature sensor
B	Outlet water temperature sensor
C	Water differential pressure switch
D	Vent valve
E	Water safety valve.....(6Bar)
FS	Flow switch
G	Thermometer
----	Unit side
○	Probes

4 - Installation (continued)

Hydraulic Circuit Diagram - 2P Unit 750-900 AIR EVO

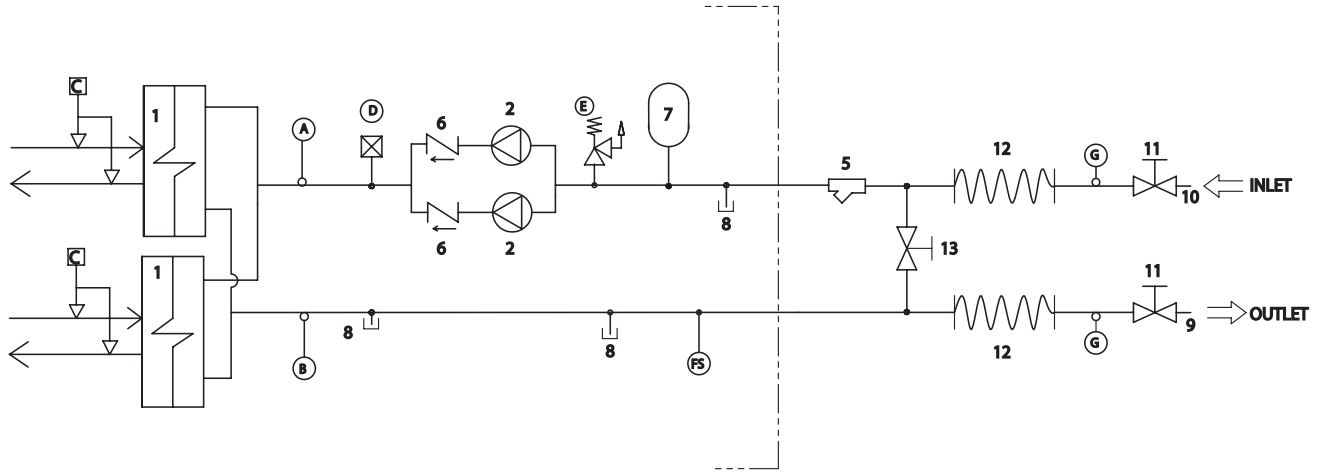

COMPONENTS	
1	Plate heat exchanger
2	Pump
3	Draining valve
4	Water buffer tank
5	Water filter
6	Non-return valve
7	Pressure expansion tank
8	Pressure point/drainage
9	Water outlet
10	Water inlet
11	Globe valve
12	Flexible pipes
13	By pass valve

SAFETY/CONTROL DEVICES	
A	Inlet water temperature sensor
B	Outlet water temperature sensor
C	Water differential pressure switch
D	Vent valve
E	Water safety valve.....(6Bar)
FS	Flow switch
G	Thermometer
-----	Unit side
○	Probes

4 - Installation (continued)

Hydraulic Circuit Diagram - 3P Unit 750-900 AIR EVO

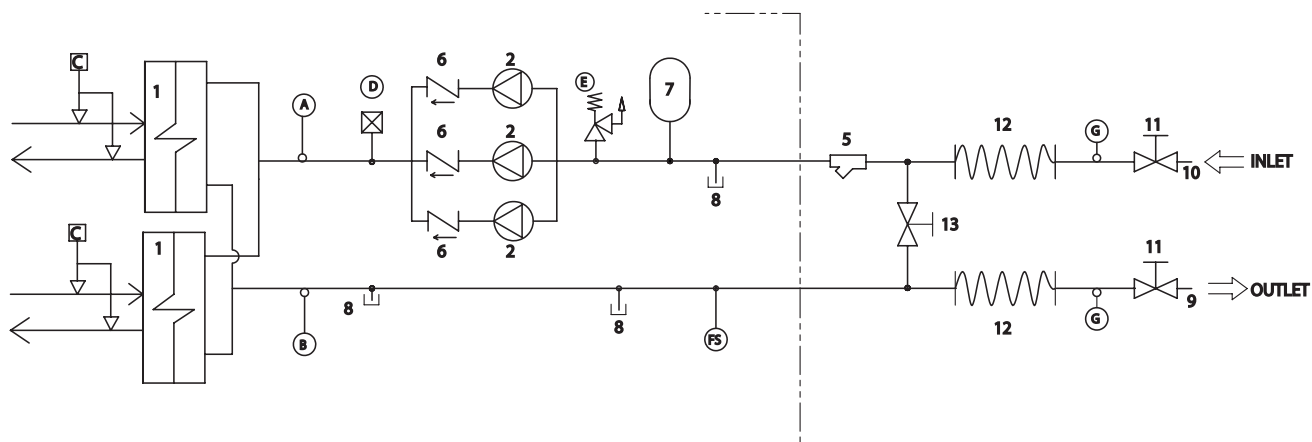

COMPONENTS	
1	Plate heat exchanger
2	Pump
3	Draining valve
4	Water buffer tank
5	Water filter
6	Non-return valve
7	Pressure expansion tank
8	Pressure point/drainage
9	Water outlet
10	Water inlet
11	Globe valve
12	Flexible pipes
13	By pass valve

SAFETY/CONTROL DEVICES	
A	Inlet water temperature sensor
B	Outlet water temperature sensor
C	Water differential pressure switch
D	Vent valve
E	Water safety valve.....(6Bar)
FS	Flow switch
G	Thermometer
----	Unit side
O	Probes

4 - Installation (continued)

Hydraulic Circuit Diagram - 1P+T Unit 400-670 AIR EVO

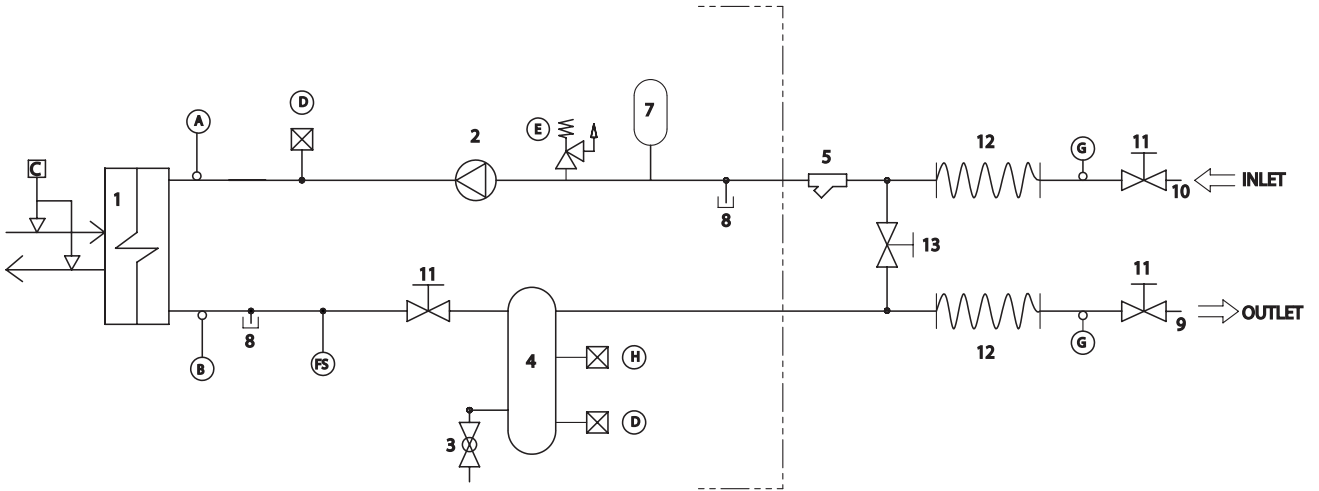

COMPONENTS	
1	Plate heat exchanger
2	Pump
3	Draining valve
4	Water buffer tank
5	Water filter
6	Non-return valve
7	Pressure expansion tank
8	Pressure point/drainage
9	Water outlet
10	Water inlet
11	Globe valve
12	Flexible pipes
13	By pass valve

SAFETY/CONTROL DEVICES	
A	Inlet water temperature sensor
B	Outlet water temperature sensor
C	Water differential pressure switch
D	Vent valve
E	Water safety valve.....(6Bar)
FS	Flow switch
G	Thermometer
----	Unit side
O	Probes

4 - Installation (continued)

Hydraulic Circuit Diagram - 2P+T Unit 400-670 AIR EVO

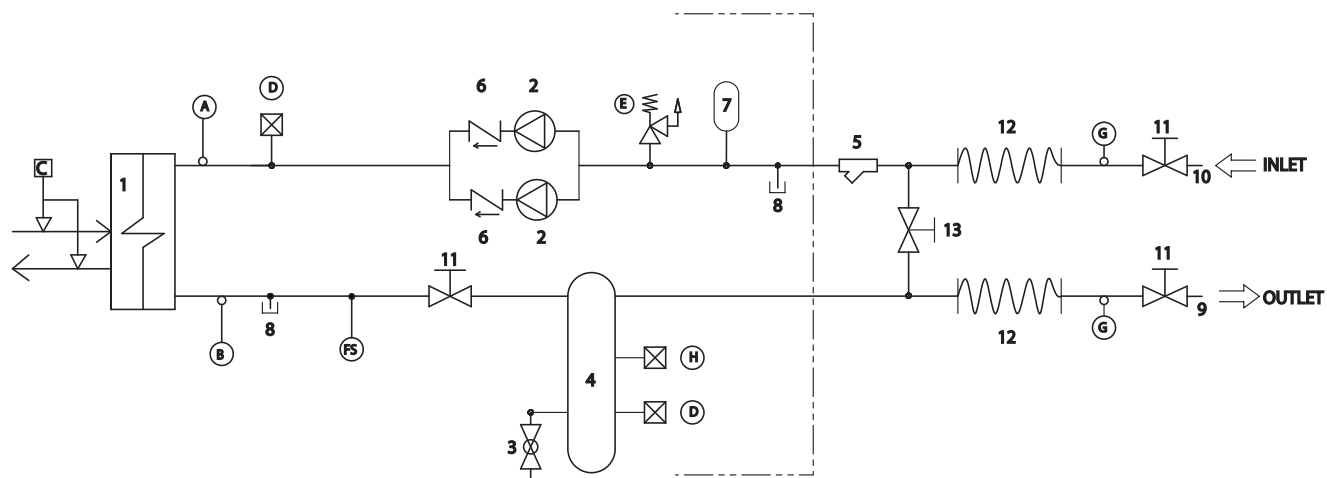

COMPONENTS	
1	Plate heat exchanger
2	Pump
3	Draining valve
4	Water buffer tank
5	Water filter
6	Non-return valve
7	Pressure expansion tank
8	Pressure point/drainage
9	Water outlet
10	Water inlet
11	Globe valve
12	Flexible pipes
13	By pass valve

SAFETY/CONTROL DEVICES	
A	Inlet water temperature sensor
B	Outlet water temperature sensor
C	Water differential pressure switch
D	Vent valve
E	Water safety valve.....(6Bar)
FS	Flow switch
G	Thermometer
----	Unit side
O	Probes

4 - Installation (continued)

4.4 Water connections



The attachments at the water inlet and outlet shall be connected in compliance with the instructions which can be found on the labels in the proximity of the attachments.

Connect the water lines of the plants with the attachments of the unit whose diameters and positions are shown by Chapter 8.

4.5 Defrost water drainage (only for Heat Pump units)

When heat pump units work in heating mode, during defrosting cycles, they may discharge water from the base. This is why the units should be installed at least 200 mm above the floor level, so as to allow the free drainage of waste water, without the risk of producing ice banks.

The heat pump units must be installed in positions where the defrosting water cannot create any damage.

4.6 Power supply



Before carrying out any operations on the electrical system, make sure that the unit is deenergised.



It is important that the appliance is grounded.



The company in charge of the installation shall conform to the standards applicable to outdoor electrical connections.

The manufacturer may not be held liable for any damage and/or injury caused by failure to comply with these precautions.

The unit conforms to EN 60204-1.

The following connections shall be provided:

- A 3-phase and grounding connection for the power supply circuit.
- The electrical distribution system shall meet the power absorbed by the appliance.
- The disconnecting and magnetothermal switches must be sized to control the starting current of the unit.
- The power supply lines and the insulation devices must be designed in such a way that every line independent.
- It is recommended to install differential switches, to prevent any damage caused by phase drops.
- The fans and compressors are supplied through contactors controlled from the control panel.
- Each motor is provided with an internal safety thermal device and external fuses.
- The power supply cables must be inserted into dedicated openings on the front of the unit, and they will enter the electrical board through holes drilled on the bottom of the board.

4 - Installation (continued)

4.7 Electrical connections

The unit must be installed on site according to the Machinery Directive (2006/42/EC), the Electromagnetic Compatibility Directive (2014/30/EU) and the usual procedures and standards applicable in the place of installation.

The unit must not be operated if its installation has not been carried out according to the instructions provided in this manual.

The power supply lines must consist of insulated copper conductors, dimensioned for the maximum absorbed current.

Connection to terminals must be performed according to the diagram of connections (User's Terminal Box) provided in this manual and according to the wiring diagram which accompanies the unit.



Before connecting the power supply lines, check that the available voltage value does not exceed the range specified in the Electric Data (Chapter 8).

For 3-phase systems, check also that the unbalance between the phases does not exceed 2%. To perform this check, measure the differences between the voltage of each phase couple and their mean value during operation.

The maximum % value of these differences (unbalance) must not exceed 2% of the mean voltage.

If the unbalance is unacceptable, contact the Energy Distributor to solve this problem.



Supplying the unit through a line whose unbalance exceeds the permissible value will automatically void the warranty.

4.8 Connecting plate-type evaporator temperature sensors

Cooling and Heat Pump units are provided with fittings for hydraulic connections between heat exchangers and plant.

Each fittings is complete with sensor well to fasten temperature sensor. Fittings are supplied separate and must be mounted during the installation of the unit.

4 - Installation (continued)

Electrical Connections SYSCROLL 400-450 AIR EVO CO/HP

QG - Y1 (EXTERNAL EQUIPMENT TERMINALS)

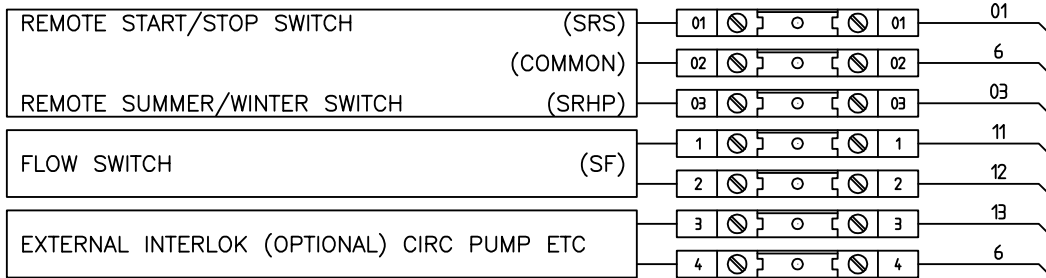

QG - Y2 (FREE VOLTAGE CONTACT)

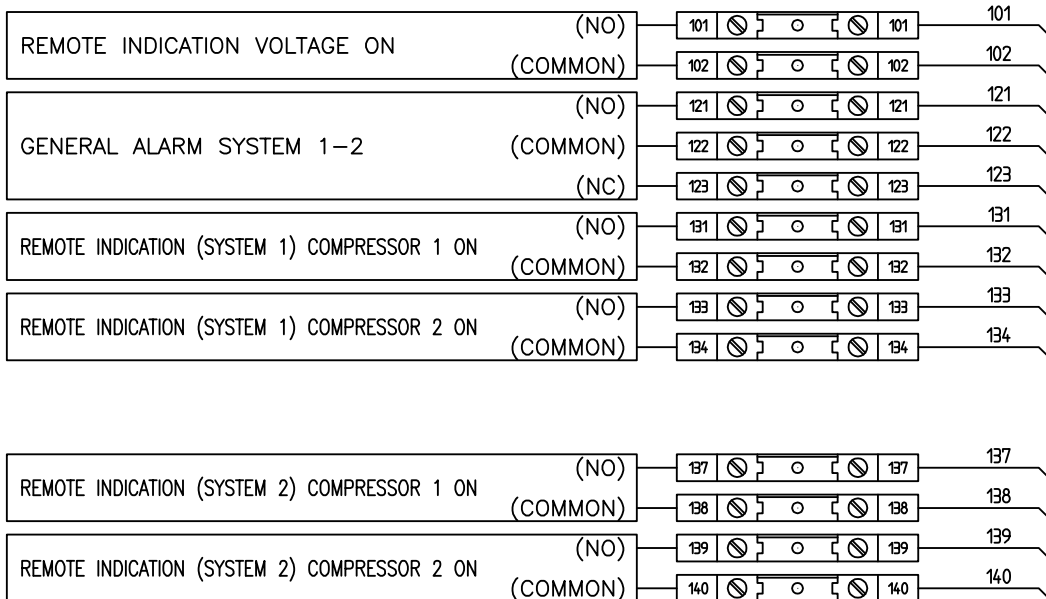

QG - Y3 (230Vac)

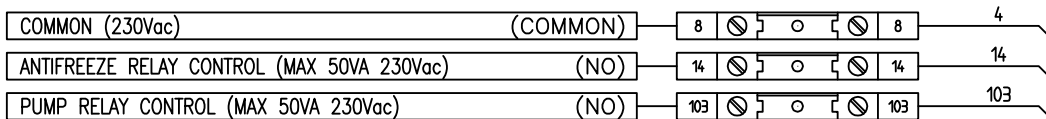

MORSETTIERA UTENTE / USER TERMINALS

4 - Installation (continued)

Electrical Connections SYSCROLL 490 AIR EVO CO/HP

QG - Y1 (EXTERNAL EQUIPMENT TERMINALS)

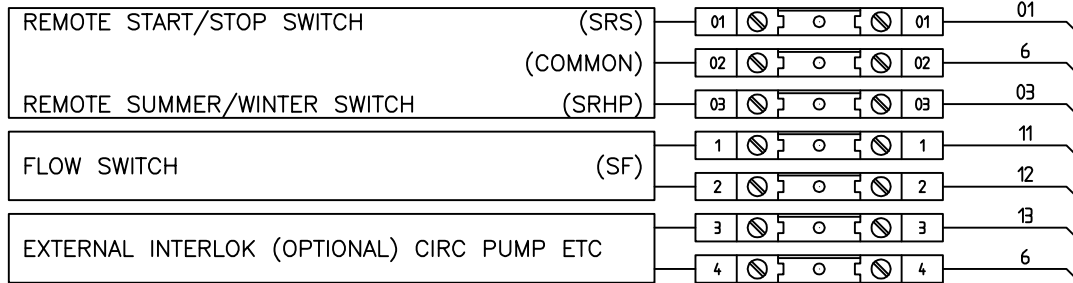

QG - Y2 (FREE VOLTAGE CONTACT)

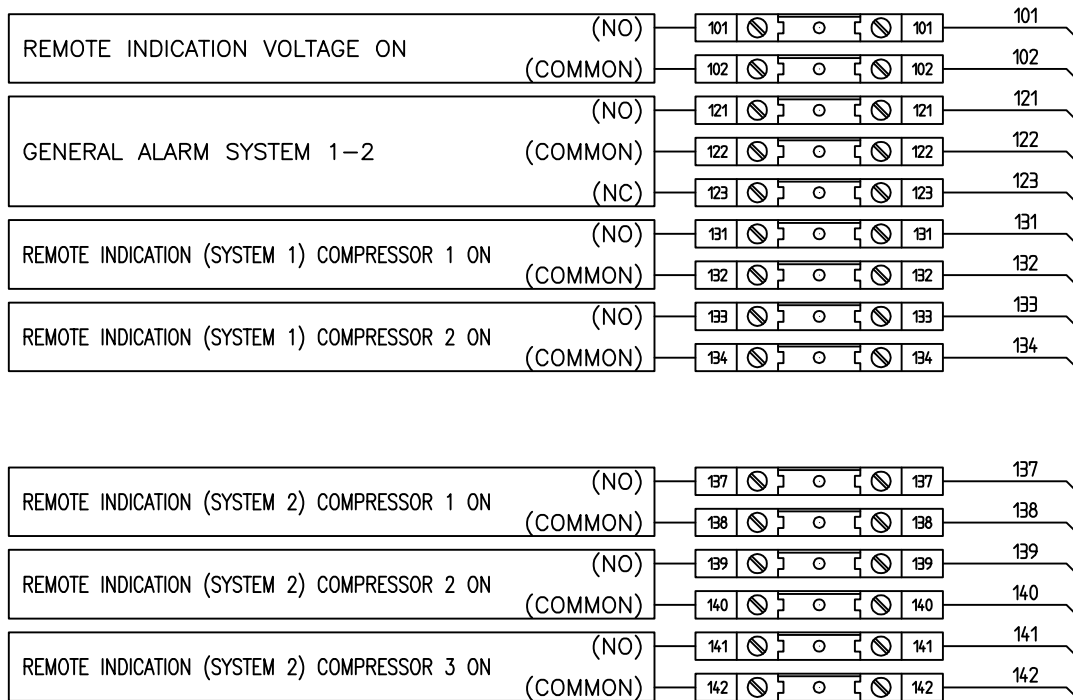

QG - Y3 (230Vac)

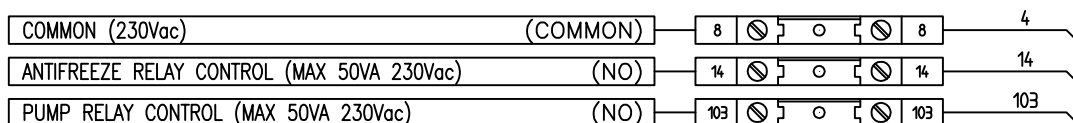

MORSETTIERA UTENTE / USER TERMINALS

4 - Installation (continued)

Electrical Connections SYSCROLL 530-670 AIR EVO CO/HP

QG - Y1 (EXTERNAL EQUIPMENT TERMINALS)

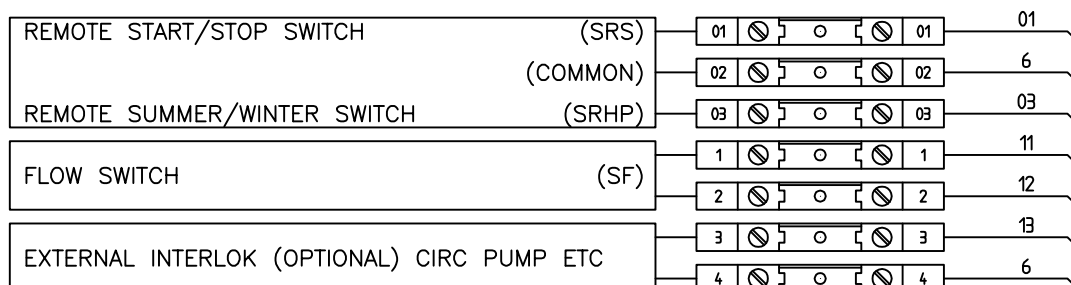

QG - Y2 (FREE VOLTAGE CONTACT)

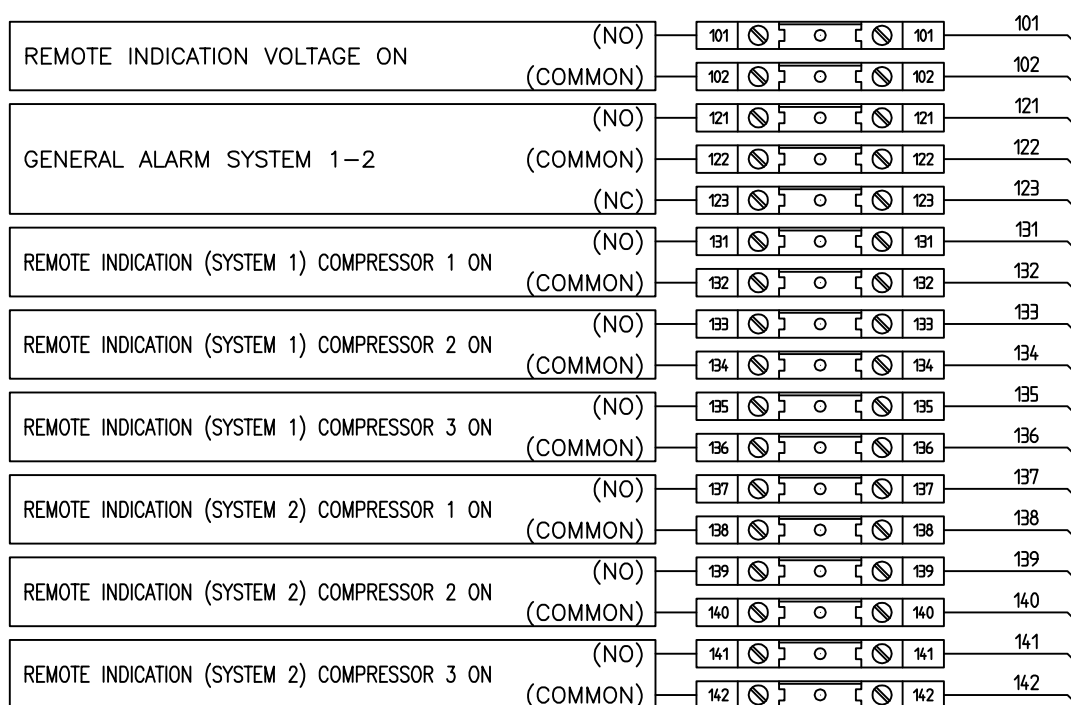

QG - Y3 (230Vac)

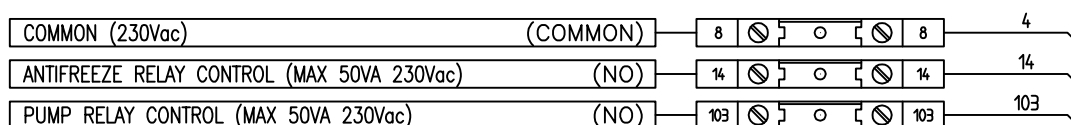

MORSETTIERA UTENTE / USER TERMINALS

4 - Installation (continued)

Electrical Connections SYSCROLL 750-900 AIR EVO CO/HP

QG - Y1 (EXTERNAL EQUIPMENT TERMINALS)

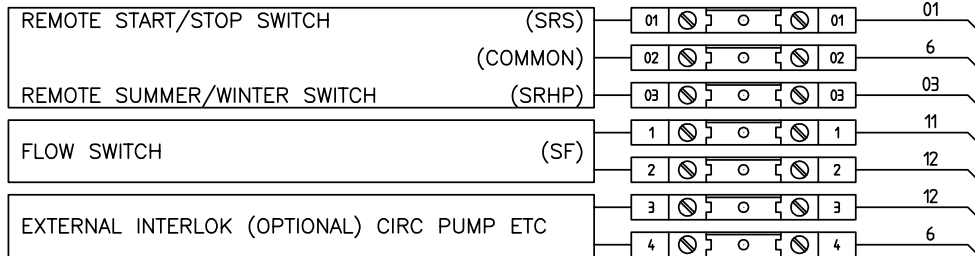

QG - Y2 (FREE VOLTAGE CONTACT)

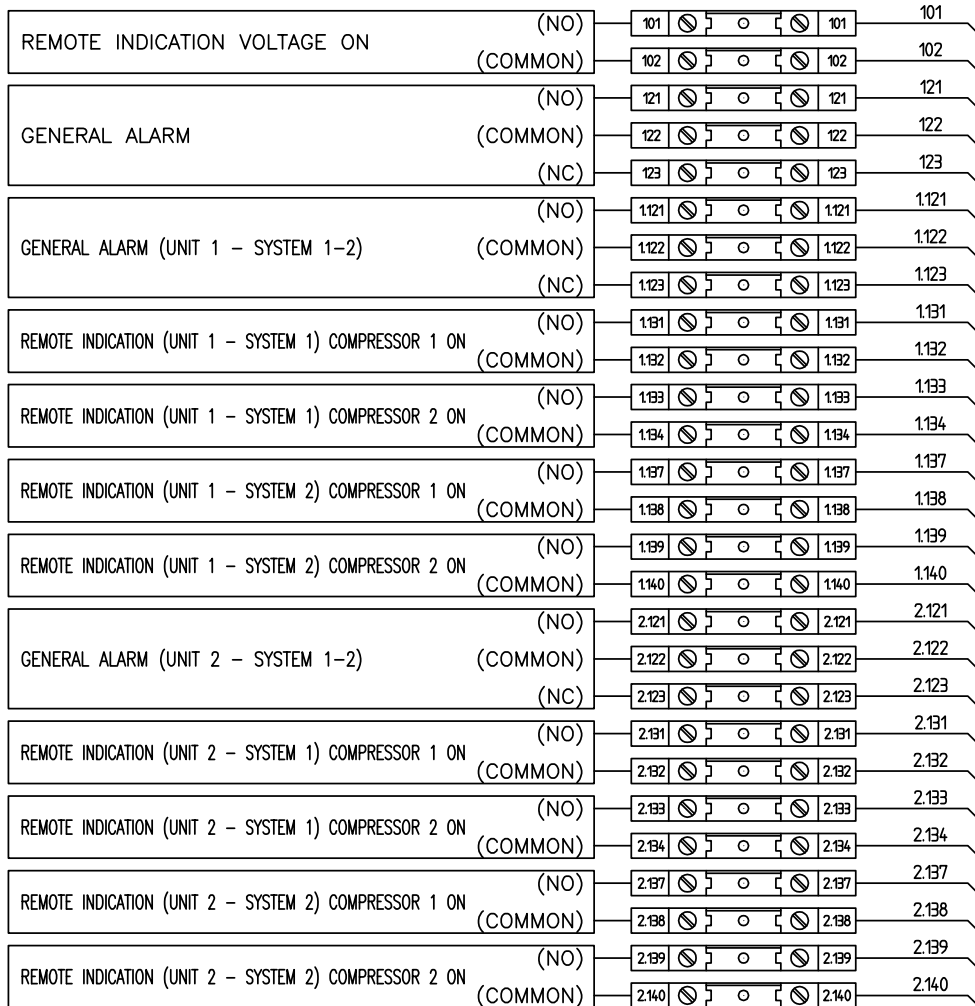

MORSETTIERA UTENTE / USER TERMINALS

QG - Y3 (230Vac)

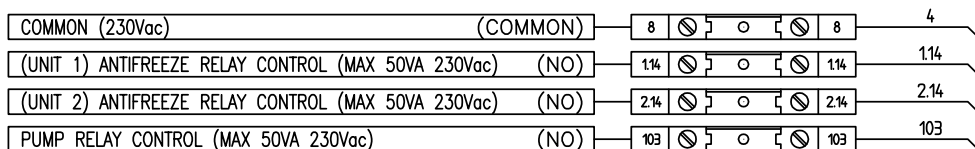

Note: For the other versions refer to documentation attached to machine.

5 - Start-Up



The unit must be started for the first time by personnel suitably trained by one Authorised Service Centre. Failure to meet this requirement will immediately void the warranty.



The operations carried out by authorised personnel are limited to the start-up of the unit, and do not include any other operation on the plant, such as, for example, electrical and hydraulic connections etc.

All the other operations before start-up, including oil pre-heating for at least 12 hours, must be performed by the Installer.

5.1 Preliminary check

The checks listed below shall be performed before starting the unit and before the arrival of the personnel authorised.

- Check the section of power supply and grounding cables; make sure that terminals are tightened and check the correct operation of contactors, with the main switch open.
- Check that any voltage and phase variation in the power supply does not exceed the prefixed thresholds.
- Connect the contacts of the flow switch and the thermal relay of the pump and of the other devices (if any), to terminals 1-2 and 3-4, respectively.
- Check that the components of the external water circuit (pump, user equipment, filters, power supply tank and reservoir, if any) have been installed properly, and according to the manufacturer's instructions.
- Check the filling of the hydraulic circuits, and make sure that the fluid circulation is correct, without any trace of leaks and air bubbles. If you use ethylene glycol as antifreeze, check that its percentage is correct (do not exceed 35% glycol percentage).
- Check that the direction of rotation of the pumps is correct, and that fluids have been circulating for at least 12 hours for both pumps. Then, clean the filters on the suction side of the pumps.
- Adjust the liquid distribution network in such a way that the flow rate is within the specified range.
- Check that the water quality is up to the specifications.
- Check that oil heaters, if any, have been turned on at least 12 hours before.

5.2 Start-up

Start-up sequence:

- Turn on the Main switch (at least 12 hours before).
- Check that the oil in the compressor has reached the requested temperature (the minimum temperature outside the pan must be approx. 40°C) and that the auxiliary control circuit is energised.
- Check the operation of all the external equipment, and make sure that the control devices of the plant are properly calibrated.

- Start the pump and check that the water flow is correct.
- Set the desired fluid temperature on the control board.
- Start the appliance (see Chapter 6).
- Check the correct direction of rotation of compressors. Scroll compressors cannot compress the refrigerant when they rotate in the opposite direction. To make sure that they are rotating in the correct direction, simply check that, just after the start-up of the compressor, the pressure drops on the LP side and rises on the HP side. Furthermore, if a scroll compressor rotate in the opposite direction, there is a considerable rise in the sound level of the unit, as well as in a dramatic reduction of current absorption compared to normal values. In case of wrong rotation, the scroll compressor can be definitely damaged. Phase monitor is assembled in the unit as a standard to prevent wrong compressors rotation.
- After about 15 minutes of operation check that there are no bubbles, through the sight glass on the liquid line.



The presence of bubbles may indicate that a part of the refrigerant charge has been released in one or more points. It is important to remove these leaks before proceeding.

- Repeat the start-up procedure after removing the leaks.

5.3 Checking the operation

Check the following:

- The temperature of the water entering the evaporator.
- The temperature of the water leaving the evaporator.
- The level of the water flow rate in the evaporator, if possible.
- The current absorption upon the start of the compressor and in case of stabilised operation.
- The fan's current absorption.

Check that the condensing and evaporation temperatures, during operation at high and low pressure detected by the pressure gauges of the refrigerant, are within the following range:

(On the units not provided with HP/LP pressure gauges for the refrigerant, connect a pressure gauge to the Schrader valves on the refrigeration circuit).

HP side	Approx. 11 to 15 °C above the temperature of the air entering the condenser, for R410A units.
LP side	Approx. 2 to 4 °C below the temperature of the leaving chilled water, for R410A units.

5.4 Delivery to the customer

- Train the user according to the instructions provided in Section 6.

6 - Control

6 General information

Introduction

This document contains the information and the operating instructions for units equipped with 4/5/6/8 compressors.

This information is for the after-sales service and the production operators, for the end-of-line testing.

Main characteristics

- Microprocessor control
- User-friendly keyboard
- Proportional and integral control of the return water temperature (RWT)
- Hysteresis control of the leaving water temperature (LWT)
- Access code to enter the Manufacturer's Level
- Access code to enter the Assistance Level
- Alarm and LED
- Backlighting LCD
- Pump-Down logic
- Rotation of the compressor operation
- Oil return function
- Night mode (or Low Noise) control
- Counting of the pump/compressors' hours of operation
- Display of discharge and suction pressure values
- Display of temperature sensor
- History of stored alarms (option)
- Built-in serial Communication RS485 Card.

The following accessories can be also connected:

- Remote Display Terminal
- Wire Remote Control.

6.1 The "CHILLER CONTROL" system

The machines are provided with a microprocessor card which is fully programmed by default for the control of a unit with 2/4 circuits, 2/3 compressors per circuit, a high and a low pressure transducer per circuit.

The control system consists of:

Keyboard & Display Terminal

General information

The figure shows the terminal with the front door open.

It is provided with a LCD 8 lines x 22 columns, keyboard and microprocessor-controlled LED's, so as to allow the programming of the control parameters (setpoint, differential bands, alarm thresholds) and remain operations to be carried out by the user.



Terminal & Key Board description







The terminal makes it possible to carry out the following operations:

- the initial configuration of the machine
- the change of all the main operating parameters
- the display of the detected alarms
- the display of all the measured quantities

The terminal and the card are connected by a 6-way phone cable.

The connection of the terminal to the basic card is not essential for the normal operation of the controller.

6 - Control (continued)

	Esc key: allows you to move from one mask to another.
	Alarm key: used to display the alarms, to reset them in manual. Press it one to display the mask of the activated alarm, press it again to reset the alarm signal.
	Prg+Esc keys: Pressing these keys at the same time, allows you to turn the unit on/off.
	Up-down keys: allows you to set the control parameters' values and to move from one mask to another (not backlighted).
	Enter key: used to move the cursor inside the masks and to save the values of the set parameters.
	Alarm + Enter keys: press these keys at the same time to enter the "historical alarm" after 1' come back at status machine menu.

6.2 Display



The display is an LCD 4 lines x 20 columns. The quantities and the information about the operation of the unit are alternated in the form of subsequent screens, named.

6.3 Keyboard

Arrows key - Up/Down/Enter

If the cursor is in the top left-hand corner (Home), press the UP/DOWN keys to access the subsequent masks associated to the selected branch. If a mask includes some value setting fields and you press the ENTER key, the cursor will reach these fields.

Once you have reached the quantity setting field, you can modify any value (within the expected limits) by pressing the UP/DOWN keys.

After you have selected the desired value, press the ENTER key again to store it.

6 - Control (continued)

Alarms list SYSCROLL 400-670 AIR EVO

Alarm code	Description	Notes
1	Main board - EPROM Failure	
2	Main board - Clock card Failure	
3	Main board - External air temperature sensor fault	
4	Main board - Return Water temperature sensor fault	
5	Main board - Leaving Water temperature sys 1 sensor fault	
6	Main board - Leaving Water temperature sys 2 sensor fault	
7	Main board - Low pressure sys 1 sensor fault	
8	Main board - Low pressure sys 2 sensor fault	
9	Main board - High pressure sys 1 sensor fault	
10	Main board - High pressure sys 2 sensor fault	
11	Main board - Discharge temperature sys 1 sensor fault	
12	Main board - Discharge temperature sys 2 sensor fault	
13	Main board - Coil Temperature sys 1 sensor fault	
14	Main board - Coil Temperature sys 2 sensor fault	
15	Flow switch / Interlock / Serious alarm (SQZ)	
16	Serious alarm (SQZ)	
17	Flow switch / Interlock	
20	High pressure switch Sys 1	
21	High pressure switch Sys 2	
22	Low pressure Sys 1 switch manual reset	
23	Low pressure Sys 2 switch manual reset	
24	Thermal protection compressor 1 Sys 1 manual reset	
25	Thermal protection compressor 2 Sys 1 manual reset	
26	Thermal protection compressor 3 Sys 1 manual reset	
27	Thermal protection compressor 1 Sys 2 manual reset	
28	Thermal protection compressor 2 Sys 2 manual reset	
29	Thermal protection compressor 3 Sys 2 manual reset	
30	Fan Thermal protection manual reset	
31	Fan Thermal protection Group 1 Sys 1 manual reset	
32	Fan Thermal protection Group 2 Sys 1 manual reset	
33	Fan Thermal protection Group 1 Sys 2 manual reset	
34	Fan Thermal protection Group 2 Sys 2 manual reset	
35	Low refrigerant cutout Sys 1 manual reset	
36	Low refrigerant cutout Sys 2 manual reset	
37	Low pressure alarm Sys 1 manual reset	
38	Low pressure alarm Sys 2 manual reset	
39	Out of envelope Sys 1 manual reset	
40	Out of envelope Sys 2 manual reset	
41	High pressure Sys 1 manual reset	
42	High pressure Sys 2 manual reset	
43	High limit discharge temperature Sys1 manual reset	
44	High limit discharge temperature Sys2 manual reset	
45	ΔT Water Too High Sys1	
46	ΔT Water Too High Sys2	
47	Wrong Water Trend Sys1	
48	Wrong Water Trend Sys2	
49	Antifreeze alarm Sys 1 manual reset	
50	Antifreeze alarm Sys 2 manual reset	
51	Antifreeze alarm Recovery manual reset	
52	Pump maintenance	
53	Compressor 1 Sys 1 maintenance	
54	Compressor 2 Sys 1 maintenance	
56	Compressor 1 Sys 2 maintenance	
57	Compressor 2 Sys 2 maintenance	
59	Driver 1 LAN disconnected	
60	Driver 2 LAN disconnected	

6 - Control (continued)

Alarms list SYSCROLL 400-670 AIR EVO (continued)

Alarm code	Description	Notes
61	EPROM Error Driver 1	
62	EPROM Error Driver 2	
63	Driver 1 S1 Sensor fault	
64	Driver 1 S3 Sensor fault	
65	Driver 1 S2 Sensor fault	
66	Driver 1 S4 Sensor fault	
67	Driver 2 S1 Sensor fault	
68	Driver 2 S3 Sensor fault	
69	EEV motor Error (Check wiring) Sys 1	
70	EEV motor Error (Check wiring) Sys 2	
71	Driver 1 Battery alarm	
72	Driver 2 Battery alarm	
73	Autotune alarm Sys 1	
74	Autotune alarm Sys 2	
75	Low suction alarm Sys 1	
76	Low suction alarm Sys 2	
77	Driver 1 Regulation Alarm	
78	Driver 2 Regulation Alarm	
79	Expansion board 1 OFF LINE	
80	Expansion board 2 OFF LINE	
81	Expansion board 1 - sensor 1 fault	
82	Expansion board 1 - sensor 2 fault	
83	Expansion board 1 - sensor 3 fault	
84	Expansion board 1 - sensor 4 fault	
85	Safety Extra Heater	
86	Recovery Flow switch	
122	Low pressure Sys 1 switch auto reset	
123	Low pressure Sys 2 switch auto reset	
124	Thermal protection compressor 1 Sys 1 auto reset	
125	Thermal protection compressor 2 Sys 1 auto reset	
126	Thermal protection compressor 3 Sys 1 auto reset	
127	Thermal protection compressor 1 Sys 2 auto reset	
128	Thermal protection compressor 2 Sys 2 auto reset	
129	Thermal protection compressor 3 Sys 2 auto reset	
130	Fan Thermal protection auto reset	
131	Fan Thermal protection Group 1 Sys 1 auto reset	
132	Fan Thermal protection Group 2 Sys 1 auto reset	
133	Fan Thermal protection Group 1 Sys 2 auto reset	
134	Fan Thermal protection Group 2 Sys 2 auto reset	
135	Low refrigerant cutout Sys 1 auto reset	
136	Low refrigerant cutout Sys 2 auto reset	
137	Low pressure alarm Sys 1 auto reset	
138	Low pressure alarm Sys 2 auto reset	
139	Out of envelope Sys 1 auto reset	
140	Out of envelope Sys 2 auto reset	
141	High pressure Sys 1 auto reset	
142	High pressure Sys 2 auto reset	
143	High limit discharge temperature Sys1 auto reset	
144	High limit discharge temperature Sys2 auto reset	

6 - Control (continued)

Alarm list SYSCROLL 750-900 AIR EVO (Master)

Alarm code	Description	Notes
M001	Main Board - EPROM Failure	
M002	Main Board - Intern Clock Failure	
M003	Sensor Fault - U1	
M004	Sensor Fault - U2	
M005	Sensor Fault - U3	
M006	Sensor Fault - U4	
M007	Sensor Fault - U5	
M008	Sensor Fault - U6	
M009	Sensor Fault - U7	
M010	Sensor Fault - U8	
M011	Plant Side - Flowswitch / Interlock	
M012	Maintenance Plant Pump	
M013	Slave 1 Offline Manual Reset	
M014	Slave 2 Offline Manual Reset	
M015	Slave 3 Offline Manual Reset	
M016	Slave 4 Offline Manual Reset	
M017	Slave 5 Offline Manual Reset	
M018	Slave 6 Offline Manual Reset	
M019	Slave 7 Offline Manual Reset	
M020	Slave 8 Offline Manual Reset	
M113	Slave 1 Offline Auto Reset	
M114	Slave 2 Offline Auto Reset	
M115	Slave 3 Offline Auto Reset	
M116	Slave 4 Offline Auto Reset	
M117	Slave 5 Offline Auto Reset	
M118	Slave 6 Offline Auto Reset	
M119	Slave 7 Offline Auto Reset	
M120	Slave 8 Offline Auto Reset	

6 - Control (continued)

Alarm list SYSCROLL 750-900 AIR EVO (Slave)

Alarm code	Description	Notes
S001	Main Board - EPROM Failure	
S002	Main Board - Intern Clock Failure	
S003	Sensor Fault - Outdoor Temperature	
S004	Sensor Fault - Exchager Tin	
S005	Sensor Fault - Exchager Tout	
S007	Sensor Fault - SP1	Low Pressure sys 1
S008	Sensor Fault - SP2	Low Pressure sys 2
S009	Sensor Fault - DP1	High Pressure sys 1
S010	Sensor Fault - DP2	High Pressure sys 2
S011	Sensor Fault - DT1	Disch. Temp. sys 1
S012	Sensor Fault - DT2	Disch. Temp. sys 2
S013	Sensor Fault - TCoil1	Coil Temp. sys 1
S014	Sensor Fault - TCoil2	Coil Temp. sys 2
S016	Phases Sequence (SQZ)	
S017	Differential Water Pressure Switch / Interlock	
S020	SYS 1 - High Pressure Switch	
S021	SYS 2 - High Pressure Switch	
S022	SYS 1 - Low Pressure Switch Manual Reset	
S023	SYS 2 - Low Pressure Switch Manual Reset	
S024	SYS 1 - Comp. 1 Overload Manual Reset	
S025	SYS 1 - Comp. 2 Overload Manual Reset	
S026	SYS 1 - Comp. 3 Overload Manual Reset	
S027	SYS 2 - Comp. 1 Overload Manual Reset	
S028	SYS 2 - Comp. 2 Overload Manual Reset	
S029	SYS 2 - Comp. 3 Overload Manual Reset	
S030	Shared Fans Overload Manual Reset	
S031	SYS 1 - Fans Group1 Overload Manual Reset	
S032	SYS 1 - Fans Group2 Overload Manual Reset	
S033	SYS 2 - Fans Group1 Overload Manual Reset	
S034	SYS 2 - Fans Group2 Overload Manual Reset	
S035	SYS 1 - Low Refrig. Cutout Manual Reset	
S036	SYS 2 - Low Refrig. Cutout Manual Reset	
S037	SYS 1 - Low Pressure Manual Reset	
S038	SYS 2 - Low Pressure Manual Reset	
S039	SYS 1 - Out of envelope Manual Reset	
S040	SYS 2 - Out of envelope Manual Reset	
S041	SYS 1 - High Pressure Manual Reset	
S042	SYS 2 - High Pressure Manual Reset	
S043	SYS 1 - High Discharge Temp Manual Reset	
S044	SYS 2 - High Discharge Temp Manual Reset	
S045	SYS 1 - Water Delta Temp Too High	
S046	SYS 2 - Water Delta Temp Too High	
S047	SYS 1 - Wrong Water Trend	
S048	SYS 2 - Wrong Water Trend	
S049	SYS 1 - Antifreeze	
S050	SYS 2 - Antifreeze	
S051	Recovery Antifreeze	
S052	Maintenance Plant Pump	
S053	Maintenance Comp.1 SYS1	
S054	Maintenance Comp.2 SYS1	
S055	Maintenance Comp.3 SYS1	
S056	Maintenance Comp.1 SYS2	
S057	Maintenance Comp.2 SYS2	
S058	Maintenance Comp.3 SYS2	
S059	Driver 1 Offline Manual Reset	
S060	Driver 2 Offline Manual Reset	

6 - Control (continued)

Alarm list SYSCROLL 750-900 AIR EVO (Slave) (continued)

Alarm code	Description	Notes
S061	EVD 1 - EPROM Fault	
S062	EVD 2 - EPROM Fault	
S063	EVD 1 - S1 Sensor Fault	
S064	EVD 1 - S3 Sensor Fault	
S067	EVD 2 - S1 Sensor Fault	
S068	EVD 2 - S2 Sensor Fault	
S069	SYS 1 - EEV Motor Error (check wiring)	
S070	SYS 2 - EEV Motor Error (check wiring)	
S071	EVD 1 - Battery Alarm	
S072	EVD 2 - Battery Alarm	
S073	SYS 1 - EEV Autotune Alarm	
S074	SYS 2 - EEV Autotune Alarm	
S075	SYS 1 - Low Suction Alarm	
S076	SYS 2 - Low Suction Alarm	
S079	Expansion 1 Offline	
S080	Expansion 2 Offline	
S081	Recovery Tin Sensor Fault	
S082	Recovery Tout Sensor Fault	
S086	Recovery FLowSwitch/Interlock	
S087	SYS 1 - Low Delta Pressure Manual Reset	
S088	SYS 2 - Low Delta Pressure Manual Reset	
S091	SYS 1 - Hi Refrig. Cutout Manual Reset	
S092	SYS 2 - Hi Refrig. Cutout Manual Reset	
S093	EVD 1 - Parameters Transmission Error	
S094	EVD 2 - Parameters Transmission Error	
S095	EVD 1 - Parameters Communication Error	
S096	EVD 2 - Parameters Communication Error	
S099	Master Offline Manual Reset	
S122	SYS 1 - Low Pressure Switch Auto Reset	
S123	SYS 2 - Low Pressure Switch Auto Reset	
S124	SYS 1 - Comp. 1 Overload Auto Reset	
S125	SYS 1 - Comp. 2 Overload Auto Reset	
S126	SYS 1 - Comp. 3 Overload Auto Reset	
S127	SYS 2 - Comp. 1 Overload Auto Reset	
S128	SYS 2 - Comp. 2 Overload Auto Reset	
S129	SYS 2 - Comp. 3 Overload Auto Reset	
S130	Shared Fans Overload Auto Reset	only μ PC
S131	SYS 1 - Fans Group1 Overload Auto Reset	only pCO5
S132	SYS 1 - Fans Group2 Overload Auto Reset	only pCO5
S133	SYS 2 - Fans Group1 Overload Auto Reset	only pCO5
S134	SYS 2 - Fans Group2 Overload Auto Reset	only pCO5
S135	SYS 1 - Low Refrig. Cutout auto Reset	
S136	SYS 2 - Low Refrig. Cutout auto Reset	
S137	SYS 1 - Low Pressure auto Reset	
S138	SYS 2 - Low Pressure auto Reset	
S139	SYS 1 - Out of envelope auto Reset	
S140	SYS 2 - Out of envelope auto Reset	
S141	SYS 1 - High Pressure auto Reset	
S142	SYS 2 - High Pressure auto Reset	
S143	SYS 1 - High Discharge Temp Auto Reset	
S144	SYS 2 - High Discharge Temp Auto Reset	
S159	Driver 1 Offline auto Reset	
S160	Driver 2 Offline auto Reset	
S187	SYS 1 - Low Delta Pressure Auto Reset	
S188	SYS 2 - Low Delta Pressure Auto Reset	
S191	SYS 1 - Hi Refrig. Cutout auto Reset	
S192	SYS 2 - Hi Refrig. Cutout auto Reset	
S199	Master Offline Auto Reset	

6 - Control (continued)

6.4 Protection and Safety Equipment

Defrosting System (only for HP models)

The HP units are provided with an automatic defrosting system, which prevents the formation of excessive ice banks on coolant/air exchangers during heat pump operation.

This system, which is part of the electronic control system, is of the time/suction pressure type, and when the suction pressure detected by a sensor drops below a fixed limit, once the preset time is over, switches from heating to cooling the operation of the unit, with the fans stopped.

During the defrosting cycle the compressor works normally, but the coil's fans remain off. The defrosting cycle stops after the coil has been defrosted, and at this point the unit can work in heating mode again.

	<p>All circuits are defrosted at the same time. For safety purposes, fans are started also during defrosting, if the discharge pressure reaches considerable values.</p>
-----------------------------------------------------------------------------------	--------------------------------------------------------------------------------------------------------------------------------------------------------------------------

Frost Protection for the Chilled Fluid

These units are provided with frost protection for the chilled fluid. This protection consists of an electrical resistor positioned in contact with the coolant/circulating fluid exchanger, which is activated (although the unit is off) when the temperature of the fluid drops below 5 °C - the standard value for a non-glycol unit.

If the leaving water temperature drops below 4 °C (standard value for a non-glycol unit) the machine's antifreeze alarm is activated. If the circulating fluid is water, before the beginning of the cold season it is advisable to drain the circuit to prevent water frosting.

If the circuit cannot be drained, it is essential to avoid de-energizing the unit, so as to permit the activation, when necessary, of the frost protection.

Compressor protection

Compressors are equipped with a heating element to prevent oil dilution, which may result in remarkable risks of failure of compressors.

The windings of the compressors' motors are provided with a thermal protection.

For models an accessory kit for thermal protection is available, for any overcurrent of scroll compressors, which shall be shop-mounted.

Electrical flow switch

To ensure the correct operation of the unit, a electrical flow switch must be installed, to prevent the unit working in case of insufficient circulation of the chilled fluid.

	<p>The electrical flow switch must be carefully installed, according to the instructions given by the Manufacturer.</p>
-----------------------------------------------------------------------------------	-------------------------------------------------------------------------------------------------------------------------

The electrical flow switch must be installed on the pressing side of the circulation pump for the fluid, just after the heat exchanger's inlet. The electrical flow switch must be installed in a horizontal straight length of piping, in a position reasonably far (both upstream and downstream) from localized pressure drops (curves, valves etc.).

Differential pressure switch

This pressure switch halts the operation of the unit in the event that it does not detect a sufficient pressure drop through the exchanger.

6 - Control (continued)

6.5 HPF version configuration

Units equipped with High pressure fan (HPF) can be set-up on the field to give the unit a specific static pressure.

By entering parameter in service level - Max Speed (Vdc) - it is

possible to modify high static pressure. The table below shows the correspondance between chiller model, fan RPM, high static pressure.

Size	Fan Static Pressure (Pa)	Fan RPM	Parameter in Service Level: Max Speed (Vdc)
400-900	0	900	8.1
	25	950	8.5
	56	1.000	9.0
	88	1.050	9.4
	124	1.100	10.0

7 - Product Description

7.1 General Information

Units are one-block type with two refrigerant circuits for 400-670 and four refrigerant circuits for 750-900. They are intended to cool down the water required for any air-conditioning application as well as any other fluid, such as for example glycol water. These units are completely assembled at works. They are equipped with all the refrigerating connections and the internal electrical wiring required for a rapid installation on the field. An operation test is performed after assembly, with water flowing through the refrigerant/water exchanger in order to make sure that the refrigerating circuit is properly working. The refrigerating circuit of every unit is pressure tested before inspection, drained and charged with R410A. A low noise level is the result of a careful study. It is achieved on chillers by using technologically advanced components without negatively affecting the operation performances and limits of the units.

7.2 Body and Frame

The base and frame of these units are made with galvanized steel elements, assembled with stainless steel screws. All panels can be removed to ensure easy access to internal components. All galvanized steel parts are protected by epoxy powder paint.

7.3 Compressors

The models are equipped with SCROLL hermetic compressors with an internal motor protection. The compressors of all models are assembled on rubber shock absorbers. Their motors can be directly started. They are cooled down by the aspirated refrigerant gas and equipped with internal thermistor protections against overloads. Overload protections are automatically reset after having tripped. The compressor terminal box has an IP54 protection degree. Compressors are powered on and off by the microprocessor of the unit control system which is intended to control the delivery of the thermal refrigerating capacity.

7.4 Evaporators

Evaporators are made of stainless steel plates. They are thermally insulated by means of a thick flexible insulating mattress with closed cells. The maximum operating pressures correspond to 10 bar for the water side and to 45 bar for the refrigerant side. Antifreeze protection for the water in the exchangers is ensured by electrical heaters and differential pressure switches.

7.5 Condensing/evaporating coils

Coils are of reversible type and are made of copper tubes arranged in staggered rows and mechanically expanded inside an aluminium finned pack. The maximum operating pressure on the refrigerant side of the condensing coils is 45 bar. The condensing coils mounted on cooling only units are of microchannel type.

7.6 Condenser Fans

The condenser fans are of a helical type. They are directly coupled and have an impeller with wing contoured aluminium blades. Each fan is equipped with a galvanised steel accident-prevention protection which is painted after manufacture. The fans motors are completely closed. They have an IP54 protection degree and a protection thermostat embedded in the windings.

7.7 Fans Control

All models have a step speed controller as a standard. It will act according to the condensing pressure and allow the operation down to an Air temperature operation of +10°C.

7.8 Refrigerating Circuit

Each unit has double refrigerating circuit equipped with external service valves intended to measure the refrigerant pressure and charge, sight glass with a humidity indicator, dryer filter and thermal expansion valve. Refrigerating circuit is also complete with high and low pressure switch as well as high and low transducer.

7.9 Control Supply Panel

All components of the control system and those necessary to start the motors are shop connected and tested. The control compartment contains an electronic card and a control board with an external keyboard and display, to show the operational functions, as well as the intervention of the alarms and the working blocks.

7 - Product Description (continued)

Refrigerant flow diagram - SYSCROLL AIR EVO CO

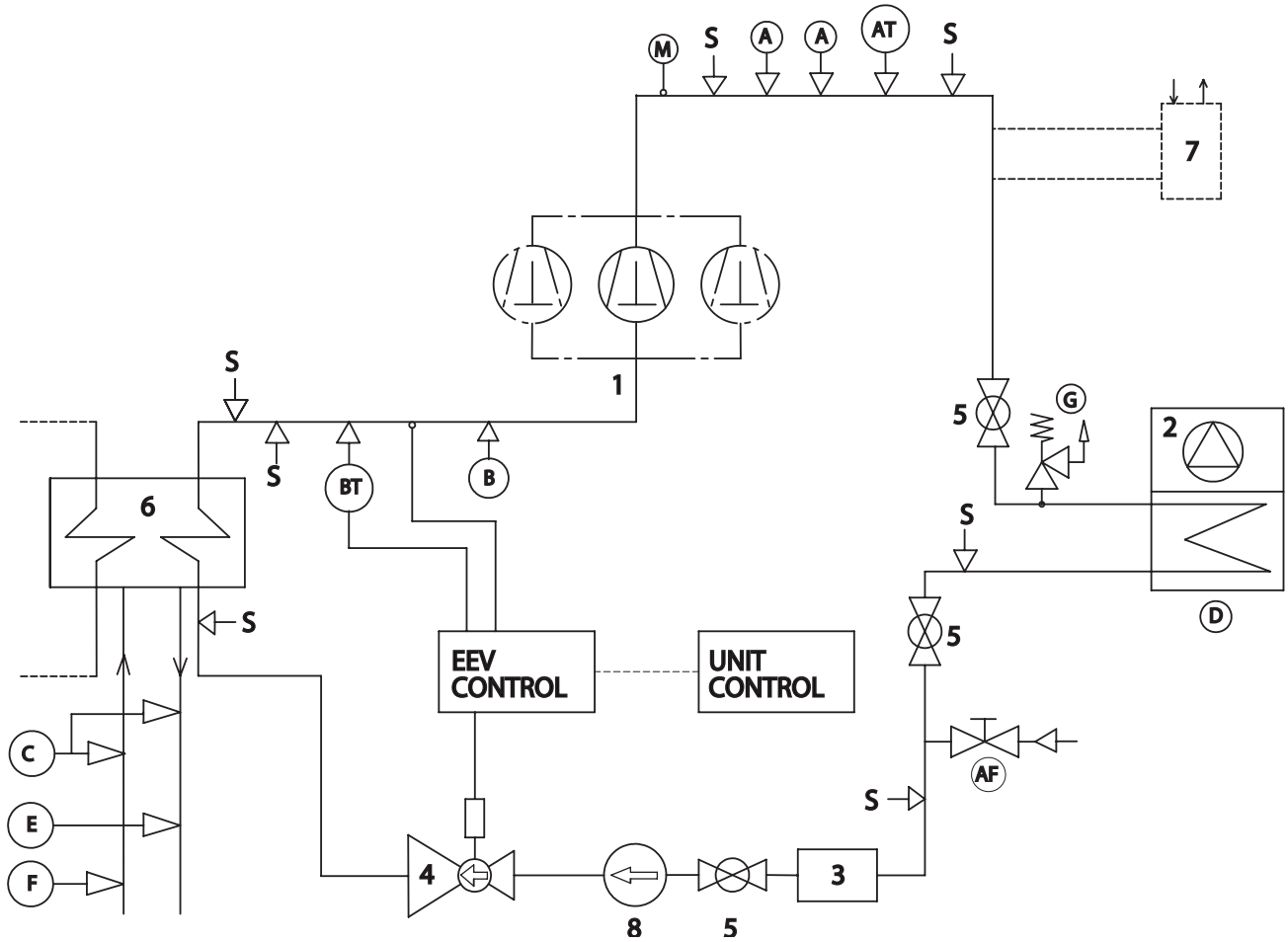

COMPONENTS	
1	Scroll type compressor
2	Air cooled condenser
3	Filter drier
4	Electronic expansion valve
5	Globe valve
6	Heat exchange (dual Type)
7	Desuperheaters (optional)
8	Sight glass

SAFETY / CONTROL DEVICES	
A	High pressure switch
AT	High pressure trasducer
AF	Access fitting sae flare 3/8"
B	Low pressure switch
BT	Low pressure trasducer
C	Water differential pressure switch
D	Air temperature sensor
E	Outlet water temperature sensor
F	Inlet water temperature sensor
G	PED pressure relief valve
M	Discharge temperature sensor
N	Suction temperature sensot
S	1/4" Schrader connection
↓	Pressure pipe connection with Schrader valve

SIZE	N° COMPRESSORS			
	CIRC.1	CIRC.2	CIRC.3	CIRC.4
400	2	2	-	-
450	2	2	-	-
490	2	3	-	-
530	3	3	-	-
580	3	3	-	-
620	3	3	-	-
670	3	3	-	-
750	2	2	2	2
800	2	2	2	2
850	2	2	2	2
900	2	2	2	2

7 - Product Description (continued)

Refrigerant flow diagram - SYSCROLL AIR EVO HP

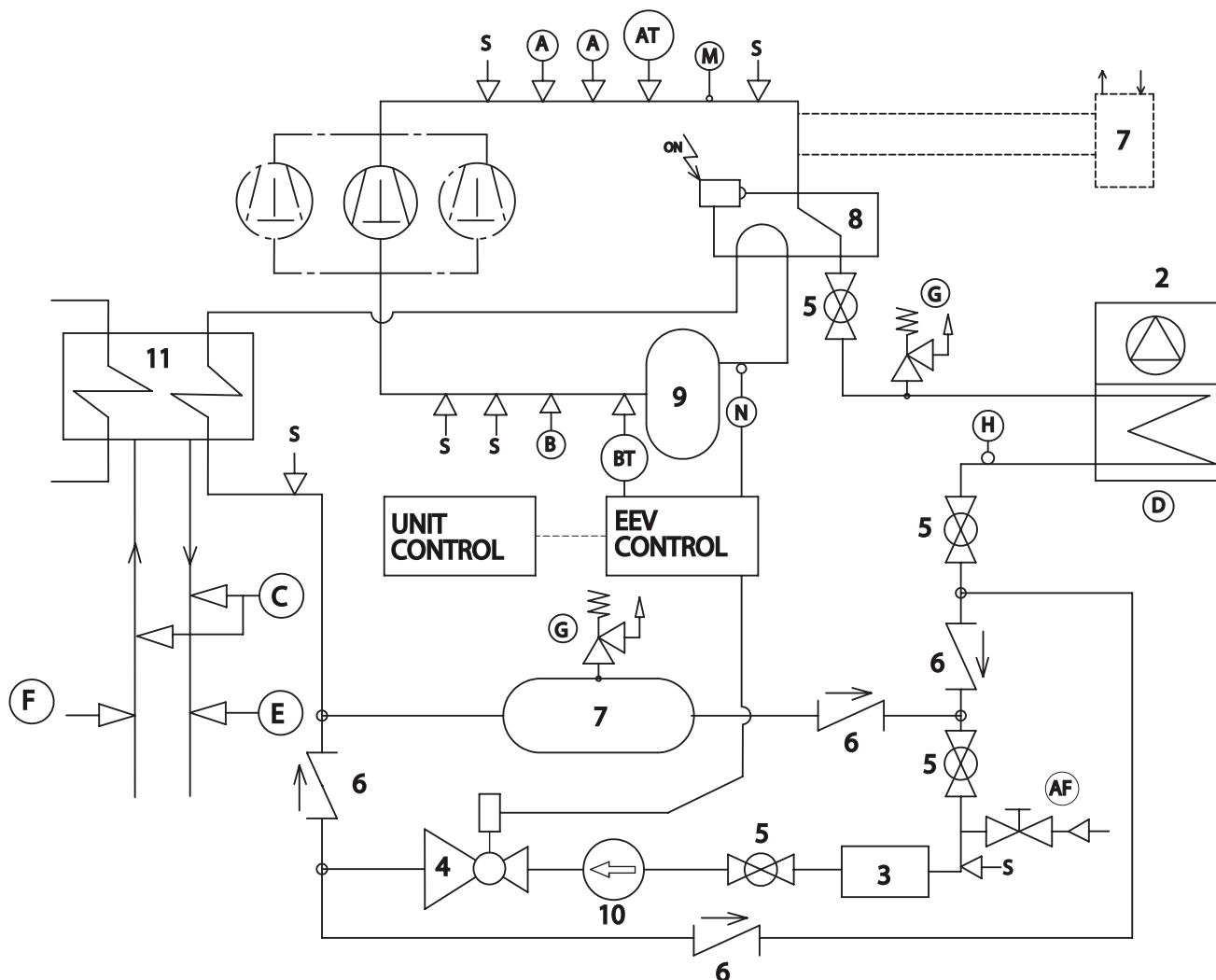

COMPONENTS	
1	Compressor tandem/trio scroll type
2	Air cooled condenser
3	Filter drier
4	Electronic expansion valve
5	Globe valve
6	Check valve
7	Liquid receiver
8	Four way valve
9	Suction accumulator
10	Sight glass
11	Heat exchange (dual Type)
12	Desuperheaters (optional)

SAFETY / CONTROL DEVICES	
A	High pressure switch
AT	High pressure trasducer
AF	Access fitting sae flare 3/8"
B	Low pressure switch
BT	Low pressure trasducer
C	Water differential pressure switch
D	Air temperature sensor
E	Outlet water temperature sensor
F	Inlet water temperature sensor
G	PED pressure relief valve
H	Defrost temperature sensor
M	Discharge temperature sensor
N	Suction temperature sensot
S	1/4" Schrader connection
↓	Pressure pipe connection with Schrader valve

SIZE	N° COMPRESSORS			
	CIRC.1	CIRC.2	CIRC.3	CIRC.4
400	2	2	-	-
450	2	2	-	-
490	2	3	-	-
530	3	3	-	-
580	3	3	-	-
620	3	3	-	-
670	3	3	-	-
750	2	2	2	2
800	2	2	2	2
850	2	2	2	2
900	2	2	2	2

7 - Product Description (continued)

Refrigerant flow diagram - SYSCROLL AIR EVO BC

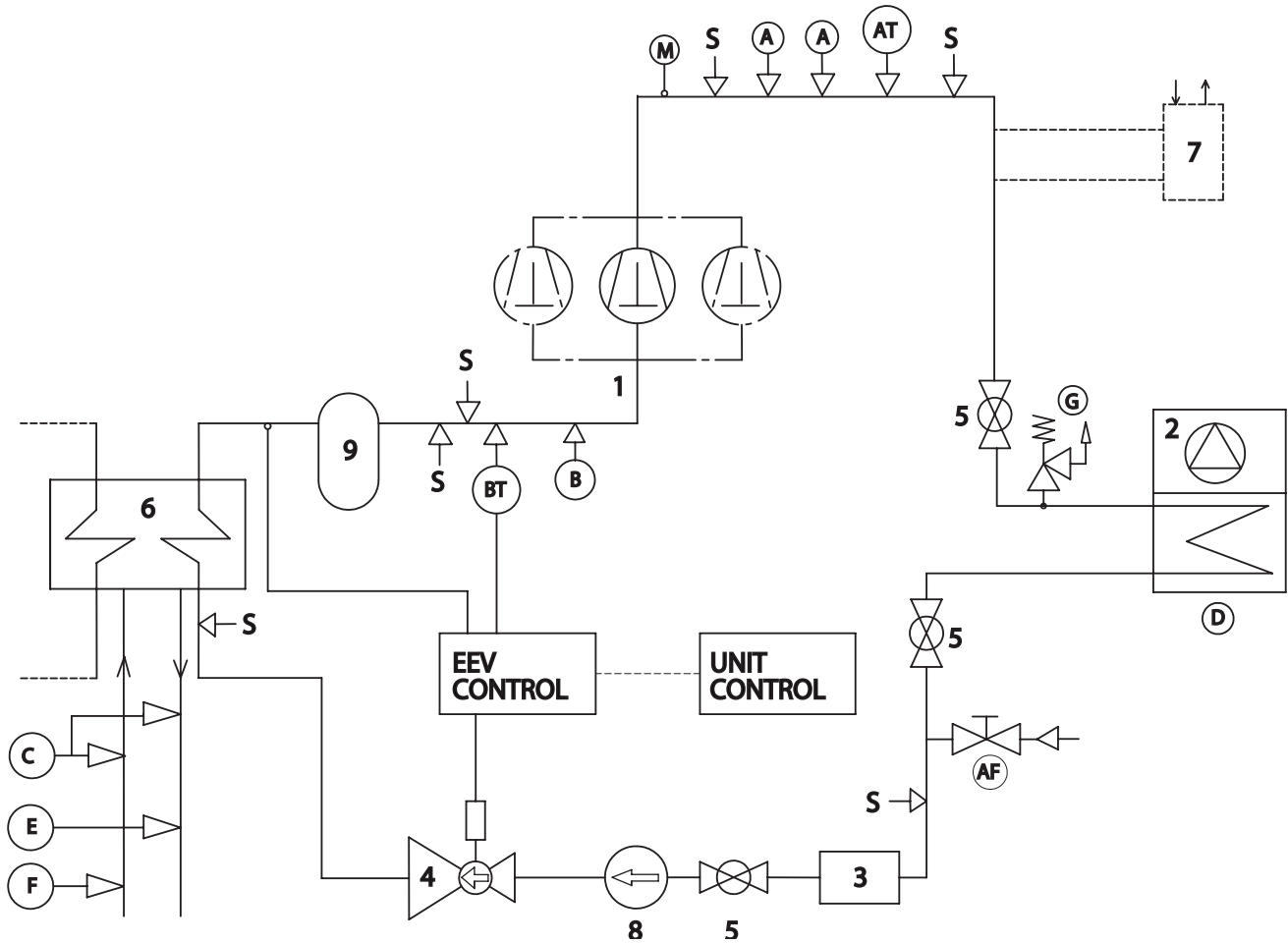

COMPONENTS	
1	Compresso tandem/trio scroll type
2	Air cooled condenser
3	Filter drier
4	Electronic expansion valve
5	Globe valve
6	Heat exchange (dual Type)
7	Desuperheaters (optional)
8	Sight glass
9	Suction accumulator

SAFETY / CONTROL DEVICES	
A	High pressure switch
AT	High pressure trasducer
AF	Access fitting sae flare 3/8"
B	Low pressure switch
BT	Low pressure trasducer
C	Water differential pressure switch
D	Air temperature sensor
E	Outlet water temperature sensor
F	Inlet water temperature sensor
G	PED pressure relief valve
M	Discharge temperature sensor
N	Suction temperature sensot
S	1/4" Schrader connection
↓	Pressure pipe connection with Schrader valve

SIZE	N° COMPRESSORS			
	CIRC.1	CIRC.2	CIRC.3	CIRC.4
400	2	2	-	-
450	2	2	-	-
490	2	3	-	-
530	3	3	-	-
580	3	3	-	-
620	3	3	-	-
670	3	3	-	-
750	2	2	2	2
800	2	2	2	2
850	2	2	2	2
900	2	2	2	2

7 - Product Description (continued)

Refrigerant flow diagram - SYSCROLL AIR EVO TR

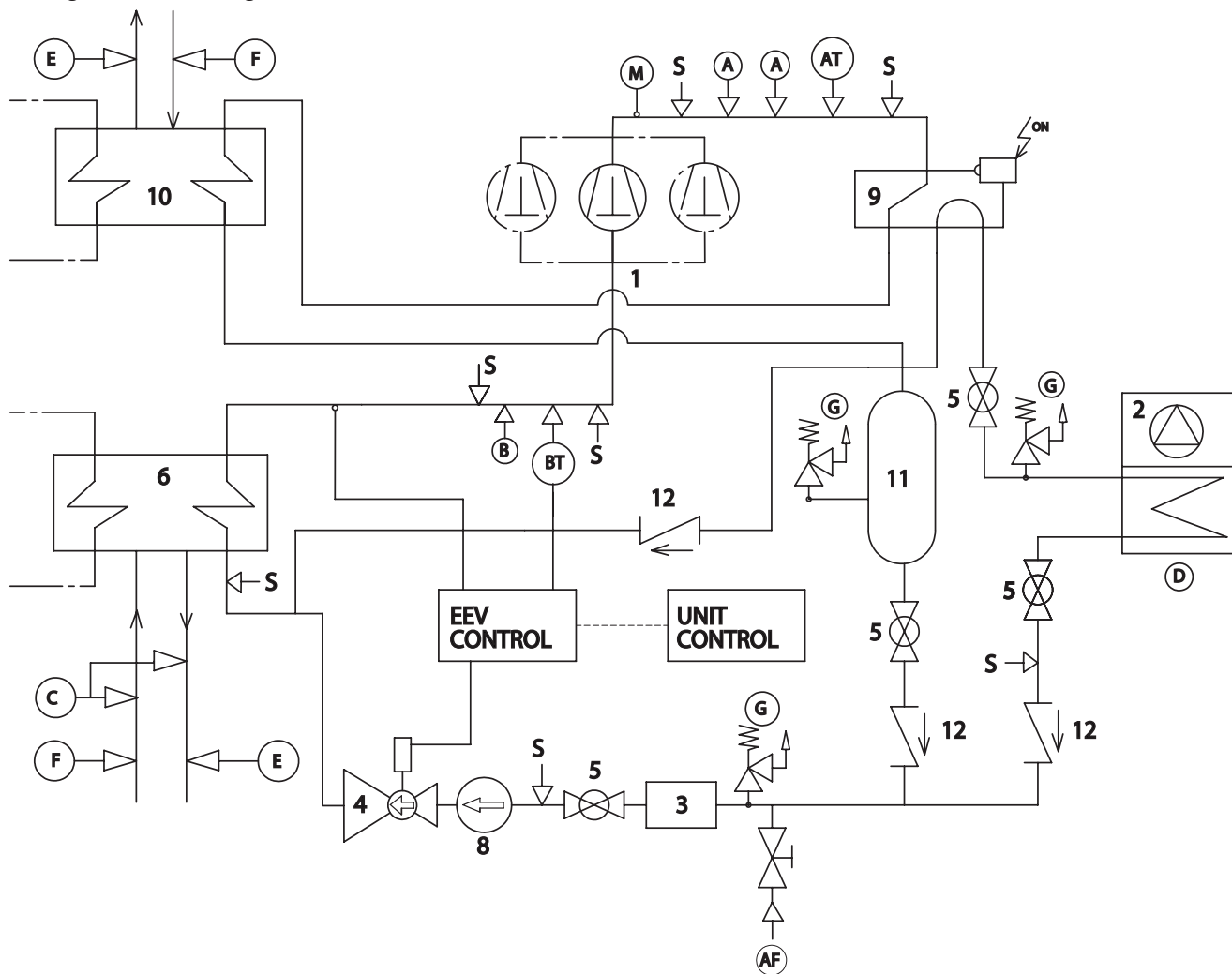

COMPONENTS	
1	Compressor tandem/trio scroll type
2	Air cooled condenser
3	Filter drier
4	Electronic expansion valve
5	Globe valve
6	Heat exchanger
8	Sight glass
9	Four way valve
10	Heat recover
11	Liquid receiver
12	Check valve
13	Suction

SAFETY / CONTROL DEVICES	
A	High pressure switch
AT	High pressure trasducer
AF	Access fitting sae flare 3/8"
B	Low pressure switch
BT	Low pressure trasducer
C	Water differential pressure switch
D	Air temperature sensor
E	Outlet water temperature sensor
F	Inlet water temperature sensor
G	PED pressure relief valve
M	Discharge temperature sensor
N	Suction temperature sensot
S	1/4" Schrader connection
↓	Pressure pipe connection with Schrader valve

SIZE	N° COMPRESSORS			
	CIRC.1	CIRC.2	CIRC.3	CIRC.4
400	2	2	-	-
450	2	2	-	-
490	2	3	-	-
530	3	3	-	-
580	3	3	-	-
620	3	3	-	-
670	3	3	-	-
750	2	2	2	2
800	2	2	2	2
850	2	2	2	2
900	2	2	2	2

8 - Technical Data

8.1 Pressure drops

EVAPORATOR PRESSURE DROP - SYSCROLL AIR EVO CO		400	450	490	530	600	670	750	800	850	900
Minimum flow rate	l/s	13,6	15,3	16,7	18,3	20,5	22,8	25,6	27,4	29,1	30,8
Nominal flow rate	l/s	19,1	21,4	23,4	25,6	28,6	32,0	35,9	38,3	40,7	43,1
Maximum flow rate	l/s	31,8	35,6	39,0	42,7	47,7	53,3	59,8	63,8	67,8	71,8
Minimum pressure drop	kPa	14	17	20	24	25	22	29	33	37	41
Nominal pressure drop	kPa	27	32	38	46	49	42	57	65	72	80
Maximum pressure drop	kPa	73	89	106	127	136	116	157	179	199	223

EVAPORATOR PRESSURE DROP - SYSCROLL AIR EVO HP		400	450	490	530	580	620	670	750	800	850	900
Minimum flow rate	l/s	12,8	14,3	15,6	16,8	18,3	19,9	21,4	24,0	25,6	27,3	28,8
Nominal flow rate	l/s	17,9	20,1	21,8	23,5	25,7	27,9	30,0	33,6	35,9	38,2	40,3
Maximum flow rate	l/s	29,8	33,5	36,3	39,1	42,8	46,4	50,0	56,1	59,8	63,6	67,1
Minimum pressure drop	kPa	12	15	17	20	20	17	19	26	29	33	36
Nominal pressure drop	kPa	24	29	33	39	40	32	37	50	56	63	70
Maximum pressure drop	kPa	64	78	92	107	109	88	102	138	155	175	195

CONDENSER PRESSURE DROP - SYSCROLL AIR EVO HP		400	450	490	530	580	620	670	750	800	850	900
Minimum flow rate	l/s	13,8	15,3	16,8	18,1	19,9	21,4	23,1	25,8	27,4	29,1	30,6
Nominal flow rate	l/s	19,3	21,5	23,5	25,3	27,9	29,9	32,3	36,1	38,4	40,7	42,8
Maximum flow rate	l/s	32,1	35,8	39,1	42,2	46,5	49,8	53,8	60,1	64,0	67,9	71,4
Minimum pressure drop	kPa	14	17	20	23	24	19	22	30	33	37	41
Nominal pressure drop	kPa	27	33	39	45	47	37	43	57	64	72	80
Maximum pressure drop	kPa	75	90	107	124	129	101	118	159	177	199	220

CONDENSER PRESSURE DROP - SYSCROLL AIR EVO TR		400	450	490	530	600	670	750	800	850	900
Minimum flow rate	l/s	17,5	19,3	21,2	23,2	25,9	29,1	32,7	35,0	36,9	38,8
Nominal flow rate	l/s	24,5	27,0	29,6	32,4	36,3	40,7	45,8	49,1	51,7	54,4
Maximum flow rate	l/s	40,9	45,1	49,4	54,1	60,5	67,8	76,3	81,8	86,2	90,6
Minimum pressure drop	kPa	23	26	32	38	41	35	47	54	59	65
Nominal pressure drop	kPa	44	51	62	74	79	68	92	106	116	128
Maximum pressure drop	kPa	121	142	170	204	218	187	255	293	321	354

8 - Technical Data (continued)

8.2 Technical data

SYSCROLL AIR EVO CO		400	450	490	530	600	670	750	800	850	900
Power supply	V/ph/Hz	400 / 3 / 50									
Total capacity steps	%	21 / 50 / 71 / 100	25 / 50 / 75 / 100	24 / 47 / 65 / 82 / 100	17 / 33 / 50 / 67 / 83 / 100	14 / 29 / 43 / 62 / 81 / 100	17 / 33 / 50 / 67 / 83 / 100	12 / 23 / 35 / 46 / 58 / 73 / 85 / 100	11 / 25 / 36 / 50 / 61 / 75 / 86 / 100	10 / 23 / 33 / 47 / 60 / 73 / 87 / 100	13 / 25 / 38 / 50 / 63 / 75 / 88 / 100
REFRIGERANT											
Type / GWP		R410A / 2088									
Charge Circuit One (1)	kg	30	36	36	43	43	49	30	30	30	36
	tCO ₂ eq	62,64	75,17	75,17	89,78	89,78	102,31	62,64	62,64	62,64	75,17
Charge Circuit Two (1)	kg	30	36	43	43	49	49	31	31	31	38
	tCO ₂ eq	62,64	75,17	89,78	89,78	102,31	102,31	64,73	64,73	64,73	79,34
Charge Circuit Three (1)	kg	-	-	-	-	-	-	31	31	38	38
	tCO ₂ eq	-	-	-	-	-	-	64,73	64,73	79,34	79,34
Charge Circuit Four (1)	kg	-	-	-	-	-	-	30	30	36	36
	tCO ₂ eq	-	-	-	-	-	-	62,64	62,64	75,17	75,17
COMPRESSOR											
Number		4	4	5	6	6	6	8	8	8	8
Type		Scroll / PVE									
N° of loading stages		0 / 100									
EVAPORATOR											
Number		1	1	1	1	1	1	2	2	2	2
Type		Brazen plates heat exchanger									
Water flow	m ³ /h	68,8	76,9	84,2	92,2	103,1	115,1	129,2	137,9	146,4	155,1
Pressure drop	kPa	27	32	38	46	49	42	57	65	72	80
Water volume	l	43,7	49,1	49,1	49,1	53,6	54,3	80,2	87,4	92,8	98,2
Antifreeze Heater	W	130					2x130				
AIR COOLED CONDENSER											
Number of coils		8	10	11	12	13	14	16	16	18	20
Total coil face area per coil	m ²	2.3									
FANS											
Number of fans		8	10	11	12	13	14	16	16	18	20
Nominal speed	rpm	900									
Total airflow	m ³ /h	176000	220000	242000	264000	286000	308000	352000	352000	396000	440000
Total input power	kW	13,6	17	18,7	20,4	22,1	23,8	27,2	27,2	30,6	34
Total input power(*)	kW	10,64	13,3	14,63	15,96	17,29	18,62	21,28	21,28	23,94	26,6
Total input power(**)	kW	20,8	26	28,6	31,2	33,8	36,4	41,6	41,6	46,8	52
External static pressure(**)	Pa	0 to 120									
WATER CONNECTIONS (EVAPORATOR)											
Type		Victaulic									
Inlet Diameter / Outlet Diameter	inch	4" / 4"	4" / 4"	4" / 4"	4" / 4"	4" / 4"	5" / 5"	6" / 6"	6" / 6"	6" / 6"	6" / 6"
WATER CONNECTIONS (DESUPERHEATER)											
Type		Male GAS Threaded									
Inlet Diameter / Outlet Diameter	inch	1"1/4 / 1"1/4	1"1/4 / 1"1/4	1"1/4 / 1"1/4	1"1/4 / 1"1/4	1"1/4 / 1"1/4	2" / 2"	1"1/4 / 1"1/4	1"1/4 / 1"1/4	1"1/4 / 1"1/4	1"1/4 / 1"1/4
WEIGHT											
Shipping	kg	2930	3257	3673	3959	4197	4399	5360	5416	5703	6038
Operating	kg	3028	3367	3783	4069	4317	4524	5536	5607	5906	6253
DIMENSIONS											
Length	mm	4580	5620	6680	6680	7760	7760	8900	8900	9950	11000
Width	mm	2175	2175	2175	2175	2175	2175	2175	2175	2175	2175
Height	mm	2500	2500	2500	2500	2500	2500	2500	2500	2500	2500

(1) The refrigerant value are indicative values for standard units. The actual data are indicated on the unit label.

(*) High Efficiency Units (EC) with inverter fans.

(**) HPF Units with high static pressure fans

8 - Technical Data (continued)

SYSCROLL AIR EVO CO SLN		400	450	490	530	600	670	750	800	850
Power supply	V/ph/Hz	400 / 3 / 50								
Total capacity steps	%	21 / 50 / 71 / 100	25 / 50 / 75 / 100	24 / 47 / 65 / 82 / 100	17 / 33 / 50 / 67 / 83 / 100	14 / 29 / 43 / 62 / 81 / 100	17 / 33 / 50 / 67 / 83 / 100	12 / 23 / 35 / 46 / 58 / 73 / 85 / 100	11 / 25 / 36 / 50 / 61 / 75 / 86 / 100	10 / 23 / 33 / 47 / 60 / 73 / 87 / 100
REFRIGERANT										
Type / GWP		R410A / 2088								
Charge Circuit One (1)	kg	36	43	43	49	49	56	36	36	36
	tCO ₂ eq	75,17	89,78	89,78	102,31	102,31	116,93	75,17	75,17	75,17
Charge Circuit Two (1)	kg	36	43	49	49	56	56	38	38	38
	tCO ₂ eq	75,17	89,78	102,31	102,31	116,93	116,93	79,34	79,34	79,34
Charge Circuit Three (1)	kg	-	-	-	-	-	-	38	38	44
	tCO ₂ eq	-	-	-	-	-	-	79,34	79,34	91,87
Charge Circuit Four (1)	kg	-	-	-	-	-	-	36	36	43
	tCO ₂ eq	-	-	-	-	-	-	75,17	75,17	89,78
COMPRESSOR										
Number		4	4	5	6	6	6	8	8	8
Type		Scroll / PVE								
N° of loading stages		0 / 100								
EVAPORATOR										
Number		1	1	1	1	1	1	2	2	2
Type		Brazen plates heat exchanger								
Water flow	m ³ /h	68,3	76,0	82,9	90,6	101,0	112,5	128,4	136,9	144,9
Pressure drop	kPa	26	31	37	45	47	40	56	64	70
Water volume	l	43,7	49,1	49,1	49,1	53,6	54,3	80,2	87,4	92,8
Antifreeze Heater	W	130					2x130			
AIR COOLED CONDENSER										
Number of coils		10	12	13	14	15	16	20	20	22
Total coil face area per coil	m ²	2,3								
FANS										
Number of fans		10	12	13	14	15	16	20	20	22
Nominal speed	rpm	700								
Total airflow	m ³ /h	175000	210000	227500	245000	262500	280000	350000	350000	385000
Total input power	kW	10	12	13	14	15	16	20	20	22
Total input power*	kW	6,7	8,0	8,7	9,4	10,1	10,7	13,4	13,4	14,7
WATER CONNECTIONS (EVAPORATOR)										
Type		Victaulic								
Inlet Diameter / Outlet Diameter	inch	4" / 4"	4" / 4"	4" / 4"	4" / 4"	4" / 4"	5" / 5"	6" / 6"	6" / 6"	6" / 6"
WATER CONNECTIONS (DESUPERHEATER)										
Type		Male GAS Threaded								
Inlet Diameter / Outlet Diameter	inch	1"1/4 / 1"1/4	1"1/4 / 1"1/4	1"1/4 / 1"1/4	1"1/4 / 1"1/4	1"1/4 / 1"1/4	2" / 2"	1"1/4 / 1"1/4	1"1/4 / 1"1/4	1"1/4 / 1"1/4
WEIGHT										
Shipping	kg	3220	3546	3959	4259	4477	4664	5935	5992	6296
Operating	kg	3318	3656	4069	4369	4597	4789	6111	6183	6499
DIMENSIONS										
Length	mm	5620	6680	7760	7760	8800	8800	11000	11000	12050
Width	mm	2175	2175	2175	2175	2175	2175	2175	2175	2175
Height	mm	2500	2500	2500	2500	2500	2500	2500	2500	2500

(1) The refrigerant value are indicative values for standard units. The actual data are indicated on the unit label.

(*) High Efficiency Units (EC) with inverter fans.

8 - Technical Data (continued)

SYSCROLL AIR EVO CO HT		400	450	490	530	600	670	750	800	850
Power supply	V/ph/Hz	400 / 3 / 50								
Total capacity steps	%	21 / 50 / 71 / 100	25 / 50 / 75 / 100	24 / 47 / 65 / 82 / 100	17 / 33 / 50 / 67 / 83 / 100	14 / 29 / 43 / 62 / 81 / 100	17 / 33 / 50 / 67 / 83 / 100	12 / 23 / 35 / 46 / 58 / 73 / 85 / 100	11 / 25 / 36 / 50 / 61 / 75 / 86 / 100	10 / 23 / 33 / 47 / 60 / 73 / 87 / 100
REFRIGERANT										
Type / GWP		R410A / 2088								
Charge Circuit One (1)	kg	36	43	43	49	49	56	36	36	36
	tCO ₂ eq	75,17	89,78	89,78	102,31	102,31	116,93	75,17	75,17	75,17
Charge Circuit Two (1)	kg	36	43	49	49	56	56	38	38	38
	tCO ₂ eq	75,17	89,78	102,31	102,31	116,93	116,93	79,34	79,34	79,34
Charge Circuit Three (1)	kg	-	-	-	-	-	-	38	38	44
	tCO ₂ eq	-	-	-	-	-	-	79,34	79,34	91,87
Charge Circuit Four (1)	kg	-	-	-	-	-	-	36	36	43
	tCO ₂ eq	-	-	-	-	-	-	75,17	75,17	89,78
COMPRESSOR										
Number		4	4	5	6	6	6	8	8	8
Type		Scroll / PVE								
N° of loading stages		0 / 100								
EVAPORATOR										
Number		1	1	1	1	1	1	2	2	2
Type		Brazen plates heat exchanger								
Water flow	m ³ /h	70,9	78,6	85,8	93,8	104,8	117,1	132,7	141,8	149,9
Pressure drop	kPa	28	34	40	48	51	43	60	68	75
Water volume	l	43,7	49,1	49,1	49,1	53,6	54,3	80,2	87,4	92,8
Antifreeze Heater	W	130						2x130		
AIR COOLED CONDENSER										
Number of coils		10	12	13	14	15	16	20	20	22
Total coil face area per coil	m ²	2,3								
FANS										
Number of fans		10	12	13	14	15	16	20	20	22
Nominal speed	rpm	900								
Total airflow	m ³ /h	220000	264000	286000	308000	330000	352000	440000	440000	484000
Total input power	kW	13,3	15,96	17,29	18,62	19,95	21,28	26,6	26,6	29,26
WATER CONNECTIONS (EVAPORATOR)										
Type		Victaulic								
Inlet Diameter / Outlet Diameter	inch	4" / 4"	4" / 4"	4" / 4"	4" / 4"	4" / 4"	5" / 5"	6" / 6"	6" / 6"	6" / 6"
WATER CONNECTIONS (DESUPERHEATER)										
Type		Male GAS Threaded								
Inlet Diameter / Outlet Diameter	inch	1"1/4 / 1"1/4	1"1/4 / 1"1/4	1"1/4 / 1"1/4	1"1/4 / 1"1/4	1"1/4 / 1"1/4	2" / 2"	1"1/4 / 1"1/4	1"1/4 / 1"1/4	1"1/4 / 1"1/4
WEIGHT										
Shipping	kg	3220	3546	3959	4259	4477	4664	5935	5992	6296
Operating	kg	3318	3656	4069	4369	4597	4789	6111	6183	6499
DIMENSIONS										
Length	mm	5620	6680	7760	7760	8800	8800	11000	11000	12050
Width	mm	2175	2175	2175	2175	2175	2175	2175	2175	2175
Height	mm	2500	2500	2500	2500	2500	2500	2500	2500	2500

(1) The refrigerant value are indicative values for standard units. The actual data are indicated on the unit label.

8 - Technical Data (continued)

SYSCROLL AIR EVO HP		400	450	490	530	580	620	670	750	800	850	900	
Power supply	V/ph/Hz	400 / 3 / 50											
Total capacity steps	%	21 / 43 / 71 / 100	25 / 50 / 75 / 100	24 / 47 / 65 / 82 / 100	17 / 33 / 50 / 67 / 83 / 100	15 / 35 / 50 / 65 / 85 / 100	14 / 32 / 45 / 64 / 82 / 100	17 / 33 / 50 / 67 / 83 / 100	12 / 23 / 35 / 46 / 58 / 69 / 85 / 100	11 / 21 / 32 / 43 / 57 / 71 / 86 / 100	10 / 20 / 33 / 47 / 60 / 73 / 87 / 100	13 / 25 / 38 / 50 / 63 / 75 / 88 / 100	
REFRIGERANT													
Type		R410A / 2088											
Charge Circuit One (1)	kg	53	65	65	77	89	89	101	53	53	53	65	
	tCO2eq	110,66	135,72	135,72	160,78	185,83	185,83	210,89	110,66	110,66	110,66	135,72	
Charge Circuit Two (1)	kg	65	65	77	77	89	101	101	54	54	66	66	
	tCO2eq	135,72	135,72	160,78	160,78	185,83	210,89	210,89	112,75	112,75	137,81	137,81	
Charge Circuit Three (1)	kg	-	-	-	-	-	-	-	54	66	66	66	
	tCO2eq	-	-	-	-	-	-	-	112,75	137,81	137,81	137,81	
Charge Circuit Four (1)	kg	-	-	-	-	-	-	-	65	65	65	65	
	tCO2eq	-	-	-	-	-	-	-	135,72	135,72	135,72	135,72	
COMPRESSOR													
Number		4	4	5	6	6	6	6	8	8	8	8	
Type / Oil Type		Scroll / POE											
N° of loading stages		0 / 100											
EVAPORATOR													
Number		1	1	1	1	1	1	1	2	2	2	2	
Type		Brazed plates heat exchanger											
Water flow cooling	m³/h	64,4	72,3	78,4	84,5	92,4	100,3	107,9	121,1	129,2	137,4	145,0	
Water pressure drop cooling	kPa	24	29	33	39	40	32	37	50	56	63	70	
Water flow heating	m³/h	69	77	84	91	100	108	116	130	138	147	154	
Water pressure drop heating	kPa	27	33	39	45	47	37	43	57	64	72	80	
Water volume	l	43,7	49,1	49,1	49,1	53,6	54,3	54,3	80,2	85,6	92,8	98,2	
Antifreeze Heater	W	130						2x130					
AIR COOLED CONDENSER													
Number of coils		9	10	11	12	14	15	16	17	18	19	20	
Total coil face area per coil	m²	2,3											
FANS													
Number of fans		9	10	11	12	14	15	16	17	18	19	20	
Nominal speed	rpm	900											
Total airflow	m³/h	198000	220000	242000	264000	308000	330000	352000	374000	396000	418000	440000	
Total input power	kW	15,3	17	18,7	20,4	23,8	25,5	27,2	28,9	30,6	32,3	34	
Total input power(*)	kW	11,97	13,3	14,63	15,96	18,62	19,95	21,28	22,61	23,94	25,27	26,6	
Total input power(**)	kW	23,4	26	28,6	31,2	36,4	39	41,6	44,2	46,8	49,4	52	
External static pressure(**)	Pa	0 to 120											
WATER CONNECTIONS (EVAPORATOR)													
Type		Victaulic											
Inlet Diameter / Outlet Diameter	inch	4" / 4"	4" / 4"	4" / 4"	4" / 4"	4" / 4"	5" / 5"	5" / 5"	6" / 6"	6" / 6"	6" / 6"	6" / 6"	
WATER CONNECTIONS (DESUPERHEATER)													
Type		Male GAS Threaded											
Inlet Diameter / Outlet Diameter	inch	1"1/4 / 1"1/4	1"1/4 / 1"1/4	1"1/4 / 1"1/4	1"1/4 / 1"1/4	1"1/4 / 1"1/4	2" / 2"	2" / 2"	1"1/4 / 1"1/4	1"1/4 / 1"1/4	1"1/4 / 1"1/4	1"1/4 / 1"1/4	
WEIGHT													
Shipping	kg	3671	3828	4302	4634	5094	5429	5566	6614	6797	7028	7193	
Operating	kg	3769	3938	4412	4744	5214	5554	5691	6790	6985	7231	7408	
DIMENSIONS													
Length	mm	5620	5620	6680	6680	7760	8800	8800	9950	9950	11000	11000	
Width	mm	2175	2175	2175	2175	2175	2175	2175	2175	2175	2175	2175	
Height	mm	2500	2500	2500	2500	2500	2500	2500	2500	2500	2500	2500	

(1) The refrigerant value are indicative values for standard units. The actual data are indicated on the unit label.

(*) High Efficiency Units (EC) with inverter fans.

(**) HPF Units with high static pressure fans

8 - Technical Data (continued)

SYSCROLL AIR EVO HP SLN		400	450	490	530	580	620	670	750	800	
Power supply	V/ph/Hz	400 / 3 / 50									
Total capacity steps	%	21 / 43 / 71 / 100	25 / 50 / 75 / 100	24 / 47 / 65 / 82 / 100	17 / 33 / 50 / 67 / 83 / 100	15 / 35 / 50 / 65 / 85 / 100	14 / 32 / 45 / 64 / 82 / 100	17 / 33 / 50 / 67 / 83 / 100	12 / 23 / 35 / 46 / 58 / 69 / 85 / 100	11 / 21 / 32 / 43 / 57 / 71 / 86 / 100	
REFRIGERANT											
Type / GWP		R410A / 2088									
Charge Circuit One (1)	kg	65	77	77	89	101	101	113	65	65	
	tCO ₂ eq	135,72	160,78	160,78	185,83	210,89	210,89	235,94	135,72	135,72	
Charge Circuit Two (1)	kg	77	77	89	89	101	113	113	66	66	
	tCO ₂ eq	160,78	160,78	185,83	185,83	210,89	235,94	235,94	137,81	137,81	
Charge Circuit Three (1)	kg	-	-	-	-	-	-	-	66	78	
	tCO ₂ eq	-	-	-	-	-	-	-	137,81	162,86	
Charge Circuit Four (1)	kg	-	-	-	-	-	-	-	77	77	
	tCO ₂ eq	-	-	-	-	-	-	-	160,78	160,78	
COMPRESSOR											
Number		4	4	5	6	6	6	6	8	8	
Type		Scroll / POE									
N° of loading stages		0/100									
EVAPORATOR											
Number		1	1	1	1	1	1	1	2	2	
Type		Braze plates heat exchanger									
Water flow cooling	m ³ /h	64,0	72,0	78,2	84,1	91,7	99,8	107,2	121,1	128,3	
Water pressure drop cooling	kPa	23	28	33	38	39	32	36	50	55	
Water flow heating	m ³ /h	69,2	77,5	84,1	91,0	100,4	107,6	116,0	130,0	138,2	
Water pressure drop heating	kPa	27	33	38	45	47	37	43	57	64	
Water volume	l	43,7	49,1	49,1	49,1	53,6	54,3	54,3	80,2	85,6	
Antifreeze Heater	W	130							2x130		
AIR COOLED CONDENSER											
Number of coils		11	12	13	14	16	17	18	21	22	
Total coil face area per coil	m ²	2,3									
FANS											
Number of fans		11	12	13	14	16	17	18	21	22	
Nominal speed	rpm	700									
Total airflow	m ³ /h	192500	210000	227500	245000	280000	297500	315000	367500	385000	
Total input power	kW	11	12	13	14	16	17	18	21	22	
Total input power*	kW	7,37	8,04	8,71	9,38	10,72	11,39	12,06	14,07	14,74	
WATER CONNECTIONS (EVAPORATOR)											
Type		Victaulic									
Inlet Diameter	inch	4" / 4"	4" / 4"	4" / 4"	4" / 4"	4" / 4"	5" / 5"	5" / 5"	6" / 6"	6" / 6"	
WATER CONNECTIONS (DESUPERHEATER)											
Type		Male GAS Threaded									
Inlet Diameter	inch	1"1/4 / 1"1/4	1"1/4 / 1"1/4	1"1/4 / 1"1/4	1"1/4 / 1"1/4	1"1/4 / 1"1/4	2" / 2"	2" / 2"	1"1/4 / 1"1/4	1"1/4 / 1"1/4	
WEIGHT											
Shipping	kg	4033	4183	4654	4991	5447	5794	5934	7321	7495	
Operating	kg	4131	4293	4764	5101	5567	5919	6059	7497	7683	
DIMENSIONS											
Length	mm	6680	6680	7760	7760	8800	9850	9850	12050	12050	
Width	mm	2175	2175	2175	2175	2175	2175	2175	2175	2175	
Height	mm	2500	2500	2500	2500	2500	2500	2500	2500	2500	

(1) The refrigerant value are indicative values for standard units. The actual data are indicated on the unit label.

(*) High Efficiency Units (EC) with inverter fans.

8 - Technical Data (continued)

SYSCROLL AIR EVO TR		400	450	490	530	600	670	750	800	850	900
Power supply	V/ph/Hz	400 / 3 / 50									
Total capacity steps	%	21 / 50 / 71 / 100	25 / 50 / 75 / 100	24 / 47 / 65 / 82 / 100	17 / 33 / 50 / 67 / 83 / 100	14 / 29 / 43 / 62 / 81 / 100	17 / 33 / 50 / 67 / 83 / 100	12 / 23 / 35 / 46 / 58 / 73 / 85 / 100	11 / 25 / 36 / 50 / 61 / 75 / 86 / 100	10 / 23 / 33 / 47 / 60 / 73 / 87 / 100	13 / 25 / 38 / 50 / 63 / 75 / 88 / 100
REFRIGERANT											
Type / GWP		R410A / 2088									
Charge Circuit One (1)	kg	30	36	36	43	43	49	30	30	30	36
	tCO ₂ eq	62,64	75,17	75,17	89,78	89,78	102,31	62,64	62,64	62,64	75,17
Charge Circuit Two (1)	kg	30	36	43	43	49	49	31	31	31	38
	tCO ₂ eq	62,64	75,17	89,78	89,78	102,31	102,31	64,73	64,73	64,73	79,34
Charge Circuit Three (1)	kg	-	-	-	-	-	-	31	31	38	38
	tCO ₂ eq	-	-	-	-	-	-	64,73	64,73	79,34	79,34
Charge Circuit Four (1)	kg	-	-	-	-	-	-	30	30	36	36
	tCO ₂ eq	-	-	-	-	-	-	62,64	62,64	75,17	75,17
COMPRESSOR											
Number		4	4	5	6	6	6	8	8	8	8
Type / Oil Type		Scroll / PVE									
N° of loading stages		0 / 100									
EVAPORATOR											
Number		1	1	1	1	1	1	2	2	2	2
Type		Braze plates heat exchanger									
Water flow	m ³ /h	68,2	74,8	81,7	89,4	100,3	112,6	126,6	136,4	143,3	150,2
Water pressure drop	kPa	26	30	36	43	47	40	55	63	69	76
Water volume	l	43,7	49,1	49,1	49,1	53,6	54,3	80,2	87,4	92,8	98,2
Antifreeze Heater	W	130						2x130			
Type water connection		Victaulic									
Inlet/Outlet Diameter water connections	inch	4" / 4"	4" / 4"	4" / 4"	4" / 4"	4" / 4"	5" / 5"	6" / 6"	6" / 6"	6" / 6"	6" / 6"
RECOVERY CONDENSER											
Number		1	1	1	1	1	1	1	2	2	2
Type		Braze plates heat exchanger									
Water flow	m ³ /h	88,3	97,4	106,7	116,8	130,8	146,5	164,8	176,6	186,2	195,7
Water pressure drop	kPa	44	51	62	74	79	68	92	106	116	128
Water volume	l	43,7	49,1	49,1	49,1	53,6	54,3	80,2	87,4	92,8	98,2
Antifreeze Heater	W	130						2x130			
Type water connection		Victaulic									
Inlet/Outlet Diameter water connections	inch	4" / 4"	4" / 4"	4" / 4"	4" / 4"	4" / 4"	5" / 5"	6" / 6"	6" / 6"	6" / 6"	6" / 6"
HYDRAULIC CONNECTIONS (EVAPORATOR)											
Type		Victaulic									
Inlet Diameter / Outlet Diameter	inch	4" / 4"	4" / 4"	4" / 4"	4" / 4"	4" / 4"	5" / 5"	6" / 6"	6" / 6"	6" / 6"	6" / 6"
WEIGHT											
Shipping	kg	3311	3653	4088	4388	4712	4975	6088	6174	6476	6832
Operating	kg	3409	3763	4198	4498	4832	5100	6264	6365	6679	7047
DIMENSIONS											
Length	mm	4580	5620	6680	6680	7760	7760	8900	8900	9950	11000
Width	mm	2175	2175	2175	2175	2175	2175	2175	2175	2175	2175
Height	mm	2500	2500	2500	2500	2500	2500	2500	2500	2500	2500

(1) The refrigerant value are indicative values for standard units. The actual data are indicated on the unit label.

8 - Technical Data (continued)

8.3 Unit electrical data

SYSCROLL AIR EVO CO/TR	400	450	490	530	600	670	750	800	850	900	
Rated voltage	V/ph/Hz 400 / 3 / 50										
Max. absorbed power	kW	191	215	236	257	289	321	362	382	406	430
Rated Current	A	226	254	281	308	343	377	431	452	480	508
Max. current FLA	A	325	363	403	443	492	541	620	650	688	726
Max. start-up current LRA	A	542	580	624	664	709	758	837	867	905	943
External fuses	A	400	400	630	630	630	630	800	800	800	800
Max. cable section (*)	mm ²	240	240	2x185	2x185	2x185	2x185	2x240	2x240	2x240	2x240

SYSCROLL AIR EVO CO/TR EC version	400	450	490	530	600	670	750	800	850	900	
Rated voltage	V/ph/Hz 400 / 3 / 50										
Max. absorbed power	kW	192	216	236	257	289	321	363	383	407	431
Rated Current	A	221	248	275	301	335	368	422	442	469	496
Max. current FLA	A	320	357	396	436	484	532	611	641	677	714
Max. start-up current LRA	A	537	574	617	657	701	749	828	858	894	931
External fuses	A	400	400	630	630	630	630	800	800	800	800
Max. cable section (*)	mm ²	240	240	2x185	2x185	2x185	2x185	2x240	2x240	2x240	2x240

SYSCROLL AIR EVO CO/TR SLN	400	450	490	530	600	670	750	800	850	850
Rated voltage	V/ph/Hz 400 / 3 / 50									
Max. absorbed power	kW	187	209	229	249	281	312	354	374	396
Rated Current	A	215	239	264	290	322	354	409	429	453
Max. current FLA	A	314	348	386	424	471	518	598	628	662
Max. start-up current LRA	A	531	565	607	645	688	735	815	845	879
External fuses	A	400	400	630	630	630	630	800	800	800
Max. cable section (*)	mm ²	240	240	2x185	2x185	2x185	2x185	2x240	2x240	2x240

SYSCROLL AIR EVO CO/TR SLN EC version	400	450	490	530	600	670	750	800	850	850
Rated voltage	V/ph/Hz 400 / 3 / 50									
Max. absorbed power	kW	196	219	240	261	293	325	371	391	415
Rated Current	A	228	254	281	308	341	375	435	455	482
Max. current FLA	A	327	364	403	442	491	539	624	654	691
Max. start-up current LRA	A	544	581	624	663	708	756	841	871	908
External fuses	A	400	400	630	630	630	630	800	800	800
Max. cable section (*)	mm ²	240	240	2x185	2x185	2x185	2x185	2x240	2x240	2x240

SYSCROLL AIR EVO CO/TR HPF version	400	450	490	530	600	670	750	800	850	900	
Rated voltage	V/ph/Hz 400 / 3 / 50										
Max. absorbed power	kW	201	227	249	271	304	337	382	402	428	454
Rated Current	A	233	263	291	319	354	389	446	466	496	526
Max. current FLA	A	332	372	413	454	503	553	635	665	704	744
Max. start-up current LRA	A	549	589	634	675	720	770	852	882	921	961
External fuses	A	400	400	630	630	630	630	800	800	800	800
Max. cable section (*)	mm ²	240	240	2x185	2x185	2x185	2x185	2x240	2x240	2x240	2x240

SYSCROLL AIR EVO CO/TR HT version	400	450	490	530	600	670	750	800	850	850
Rated voltage	V/ph/Hz 400 / 3 / 50									
Max. absorbed power	kW	207	233	255	277	311	344	394	414	440
Rated Current	A	243	272	301	329	364	399	465	485	515
Max. current FLA	A	342	382	422	463	513	563	654	684	724
Max. start-up current LRA	A	559	599	643	684	730	780	871	901	941
External fuses	A	400	400	630	630	630	630	800	800	800
Max. cable section (*)	mm ²	240	240	2x185	2x185	2x185	2x185	2x240	2x240	2x240

(*) The dimensioning of the unit's power cables is the responsibility of the installer, who shall consider: the rating, the maximum working temperature in the room, the type of insulation and the cable laying, the maximum length of the power supply line.

8 - Technical Data (continued)

SYSCROLL AIR EVO HP	400	450	490	530	580	620	670	750	800	850	900	
Rated voltage	V/ph/Hz 400 / 3 / 50											
Max. absorbed power	kW	179	199	219	239	261	281	300	339	354	378	398
Rated Current	A	234	260	286	311	341	368	394	441	468	494	521
Max. current FLA	A	331	369	404	439	481	520	558	624	662	701	739
Max. start-up current LRA	A	657	695	649	684	726	845	883	949	988	1026	1064
External fuses	A	400	400	630	630	630	630	630	800	800	800	800
Max. cable section (*)	mm ²	240	240	2x185	2x185	2x185	2x185	2x185	2x240	2x240	2x240	2x240

SYSCROLL AIR EVO HP EC version	400	450	490	530	580	620	670	750	800	850	900	
Rated voltage	V/ph/Hz 400 / 3 / 50											
Max. absorbed power	kW	180	200	220	240	262	281	301	340	360	379	399
Rated Current	A	228	254	279	304	333	359	385	431	457	483	509
Max. current FLA	A	326	363	398	432	473	511	548	614	651	389	727
Max. start-up current LRA	A	651	689	642	677	718	836	874	939	977	1015	1052
External fuses	A	400	400	630	630	630	630	630	800	800	800	800
Max. cable section (*)	mm ²	240	240	2x185	2x185	2x185	2x185	2x185	2x240	2x240	2x240	2x240

SYSCROLL AIR EVO HP SLN	400	450	490	530	580	620	670	750	800	
Rated voltage	V/ph/Hz 400 / 3 / 50									
Max. absorbed power	kW	183	203	223	243	265	285	304	347	366
Rated Current	A	242	268	293	319	349	376	402	457	483
Max. current FLA	A	339	377	412	447	489	528	566	640	678
Max. start-up current LRA	A	664	703	657	692	734	853	891	965	1003
External fuses	A	400	400	630	630	630	630	630	800	800
Max. cable section (*)	mm ²	240	240	2x185	2x185	2x185	2x185	2x185	2x240	2x240

SYSCROLL AIR EVO HP SLN EC version	400	450	490	530	580	620	670	750	800	
Rated voltage	V/ph/Hz 400 / 3 / 50									
Max. absorbed power	kW	184	203	224	244	266	285	305	348	367
Rated Current	A	235	261	286	310	339	365	391	444	470
Max. current FLA	A	332	370	404	439	480	517	555	627	665
Max. start-up current LRA	A	658	695	649	683	724	843	880	952	990
External fuses	A	400	400	630	630	630	630	630	800	800
Max. cable section (*)	mm ²	240	240	2x185	2x185	2x185	2x185	2x185	2x240	2x240

SYSCROLL AIR EVO HP HPF/PH version	400	450	490	530	580	620	670	750	800	850	900	
Rated voltage	V/ph/Hz 400 / 3 / 50											
Max. absorbed power	kW	190	211	232	254	278	299	320	359	380	401	422
Rated Current	A	242	269	295	322	354	381	409	456	484	511	539
Max. current FLA	A	339	378	414	450	494	533	572	639	678	718	757
Max. start-up current LRA	A	665	704	659	695	739	859	898	965	1004	1043	1082
External fuses	A	400	400	630	630	630	630	630	800	800	800	800
Max. cable section (*)	mm ²	240	240	2x185	2x185	2x185	2x185	2x185	2x240	2x240	2x240	2x240

(*) The dimensioning of the unit's power cables is the responsibility of the installer, who shall consider: the rating, the maximum working temperature in the room, the type of insulation and the cable laying, the maximum length of the power supply line.

8 - Technical Data (continued)

Pump electrical data 400V/3ph/50Hz

Model	Standard Pressure (SP)		High Pressure (HP)	
SYSCROLL AIR EVO CO	Nominal power	Max. running current	Nominal power	Max. running current
	kW	A	kW	A
400	5,5	10,6	7,5	13,6
450	5,5	10,6	9,2	17,2
490	7,5	13,6	9,2	17,2
530	7,5	13,6	11	21,3
600	9,2	17,4	11	21,3
670	11	20,2	15	26,6
750*	2 x 5,5	2 x 10,6	2 x 9,2	2 x 17,2
800*	2 x 5,5	2 x 10,6	2 x 9,2	2 x 17,2
850*	2 x 7,5	2 x 13,6	2 x 9,2	2 x 17,2
900*	2 x 7,5	2 x 13,6	2 x 11	2 x 21,3

Model	Standard Pressure (SP)		High Pressure (HP)	
SYSCROLL AIR EVO HP	Nominal power	Max. running current	Nominal power	Max. running current
	kW	A	kW	A
400	5,5	10,6	7,5	13,6
450	5,5	10,6	9,2	17,2
490	7,5	13,6	9,2	17,2
530	7,5	13,6	11	21,3
580	9,2	17,4	11	21,3
620	11	20,2	15	26,6
670	11	20,2	15	26,6
750*	2 x 5,5	2 x 10,6	2 x 9,2	2 x 17,2
800*	2 x 5,5	2 x 10,6	2 x 9,2	2 x 17,2
850*	2 x 7,5	2 x 13,6	2 x 9,2	2 x 17,2
900*	2 x 7,5	2 x 13,6	2 x 11	2 x 21,3

* For High Pressure (HP) option it is needed a dedicated power supply line for the pump electric board

8 - Technical Data (continued)

Compressors electrical data CO units 400V/3ph/50Hz

Model SYSCROLL AIR EVO CO / TR	System	Nominal input power	Nominal input current	Max input power	Max running	Start-up current	Nominal power factor
		Kw	A	kW	FLA	LRA	
					A	A	
400	1-1	27,0	43,6	39,0	66,0	287	0,89
	1-2	32,7	53,7	49,0	81,0	298	0,88
	2-1	27,0	43,6	39,0	66,0	287	0,89
	2-2	32,7	53,7	49,0	81,0	298	0,88
450	1-1	32,7	53,7	49,0	81,0	298	0,88
	1-2	32,7	53,7	49,0	81,0	298	0,88
	2-1	32,7	53,7	49,0	81,0	298	0,88
	2-2	32,7	53,7	49,0	81,0	298	0,88
490	1-1	32,7	53,7	49,0	81,0	298	0,88
	1-2	32,7	53,7	49,0	81,0	298	0,88
	2-1	27,0	43,6	39,0	66,0	287	0,89
	2-2	27,0	43,6	39,0	66,0	287	0,89
530	2-3	27,0	43,6	39,0	66,0	287	0,89
	1-1	27,0	43,6	39,0	66,0	287	0,89
	1-2	27,0	43,6	39,0	66,0	287	0,89
	1-3	27,0	43,6	39,0	66,0	287	0,89
600	2-1	27,0	43,6	39,0	66,0	287	0,89
	2-2	27,0	43,6	39,0	66,0	287	0,89
	2-3	27,0	43,6	39,0	66,0	287	0,89
	1-1	27,0	43,6	39,0	66,0	287	0,89
	1-2	27,0	43,6	39,0	66,0	287	0,89
	1-3	27,0	43,6	39,0	66,0	287	0,89
670	2-1	32,7	53,7	49,0	81,0	298	0,88
	2-2	32,7	53,7	49,0	81,0	298	0,88
	2-3	32,7	53,7	49,0	81,0	298	0,88
	1-1	32,7	53,7	49,0	81,0	298	0,88
	1-2	32,7	53,7	49,0	81,0	298	0,88
	1-3	32,7	53,7	49,0	81,0	298	0,88
750	2-1	32,7	53,7	49,0	81,0	298	0,88
	2-2	32,7	53,7	49,0	81,0	298	0,88
	2-3	32,7	53,7	49,0	81,0	298	0,88
	1-1	27,0	43,6	39,0	66,0	287	0,89
	1-2	27,0	43,6	39,0	66,0	287	0,89
	2-1	27,0	43,6	39,0	66,0	287	0,89
	2-2	27,0	43,6	39,0	66,0	287	0,89
	3-1	27,0	43,6	39,0	66,0	287	0,89
800	3-2	32,7	53,7	49,0	81,0	298	0,88
	4-1	27,0	43,6	39,0	66,0	287	0,89
	4-2	32,7	53,7	49,0	81,0	298	0,88
	1-1	27,0	43,6	39,0	66,0	287	0,89
	1-2	32,7	53,7	49,0	81,0	298	0,88
	2-1	27,0	43,6	39,0	66,0	287	0,89
	2-2	32,7	53,7	49,0	81,0	298	0,88
	3-1	27,0	43,6	39,0	66,0	287	0,89

8 - Technical Data (continued)

Compressors electrical data CO units 400V/3ph/50Hz (continued)

Model	System	Nominal input power	Nominal input current	Max input power	Max running	Start-up current	Nominal power factor
SYSCROLL AIR EVO CO / TR		Kw	A	kW	FLA	LRA	
		A	A	A	A	A	
850	1-1	27,0	43,6	39,0	66,0	287	0,89
	1-2	32,7	53,7	49,0	81,0	298	0,88
	2-1	27,0	43,6	39,0	66,0	287	0,89
	2-2	32,7	53,7	49,0	81,0	298	0,88
	3-1	32,7	53,7	49,0	81,0	298	0,88
	3-2	32,7	53,7	49,0	81,0	298	0,88
	4-1	32,7	53,7	49,0	81,0	298	0,88
	4-2	32,7	53,7	49,0	81,0	298	0,88
900	1-1	32,7	53,7	49,0	81,0	298	0,88
	1-2	32,7	53,7	49,0	81,0	298	0,88
	2-1	32,7	53,7	49,0	81,0	298	0,88
	2-2	32,7	53,7	49,0	81,0	298	0,88
	3-1	32,7	53,7	49,0	81,0	298	0,88
	3-2	32,7	53,7	49,0	81,0	298	0,88
	4-1	32,7	53,7	49,0	81,0	298	0,88
	4-2	32,7	53,7	49,0	81,0	298	0,88

Compressors electrical data HP units 400V/3ph/50Hz (continued)

Model	System	Nominal input power	Nominal input current	Max input power	Max running	Start-up current	Nominal power factor
SYSCROLL AIR EVO HP		Kw	A	kW	FLA	LRA	
		A	A	A	A	A	
400	1-1	25,6	44,0	36,1	65,4	310	0,84
	1-2	25,6	44,0	36,1	65,4	310	0,84
	2-1	32,5	55,3	45,0	82,6	408	0,85
	2-2	32,5	55,3	45,0	82,6	408	0,85
450	1-1	32,5	55,3	45,0	82,6	408	0,85
	1-2	32,5	55,3	45,0	82,6	408	0,85
	2-1	32,5	55,3	45,0	82,6	408	0,85
	2-2	32,5	55,3	45,0	82,6	408	0,85
490	1-1	32,5	55,3	45,0	82,6	408	0,85
	1-2	32,5	55,3	45,0	82,6	408	0,85
	2-1	25,6	44,0	36,1	65,4	310	0,84
	2-2	25,6	44,0	36,1	65,4	310	0,84
	2-3	25,6	44,0	36,1	65,4	310	0,84
530	1-1	25,6	44,0	36,1	65,4	310	0,84
	1-2	25,6	44,0	36,1	65,4	310	0,84
	1-3	25,6	44,0	36,1	65,4	310	0,84
	2-1	25,6	44,0	36,1	65,4	310	0,84
	2-2	25,6	44,0	36,1	65,4	310	0,84
	2-3	25,6	44,0	36,1	65,4	310	0,84
580	1-1	25,6	44,0	36,1	65,4	310	0,84
	1-2	32,5	55,3	45,0	82,6	408	0,85
	1-3	25,6	44,0	36,1	65,4	310	0,84
	2-1	25,6	44,0	36,1	65,4	310	0,84
	2-2	32,5	55,3	45,0	82,6	408	0,85
	2-3	25,6	44,0	36,1	65,4	310	0,84

8 - Technical Data (continued)

Compressors electrical data HP units 400V/3ph/50Hz (continued)

Model	System	Nominal input power	Nominal input current	Max input power	Max running	Start-up current	Nominal power factor
					FLA	LRA	
					A	A	
620	1-1	25,6	44,0	36,1	65,4	310	0,84
	1-2	32,5	55,3	45,0	82,6	408	0,85
	1-3	25,6	44,0	36,1	65,4	310	0,84
	2-1	32,5	55,3	45,0	82,6	408	0,85
	2-2	32,5	55,3	45,0	82,6	408	0,85
	2-3	32,5	55,3	45,0	82,6	408	0,85
670	1-1	32,5	55,3	45,0	82,6	408	0,85
	1-2	32,5	55,3	45,0	82,6	408	0,85
	1-3	32,5	55,3	45,0	82,6	408	0,85
	2-1	32,5	55,3	45,0	82,6	408	0,85
	2-2	32,5	55,3	45,0	82,6	408	0,85
	2-3	32,5	55,3	45,0	82,6	408	0,85
750	1-1	25,6	44,0	36,1	65,4	310	0,84
	1-2	25,6	44,0	36,1	65,4	310	0,84
	2-1	25,6	44,0	36,1	65,4	310	0,84
	2-2	25,6	44,0	36,1	65,4	310	0,84
	3-1	25,6	44,0	36,1	65,4	310	0,84
	3-2	25,6	44,0	36,1	65,4	310	0,84
	4-1	32,5	55,3	45,0	82,6	408	0,85
	4-2	32,5	55,3	45,0	82,6	408	0,85
800	1-1	25,6	44,0	36,1	65,4	310	0,84
	1-2	25,6	44,0	36,1	65,4	310	0,84
	2-1	25,6	44,0	36,1	65,4	310	0,84
	2-2	25,6	44,0	36,1	65,4	310	0,84
	3-1	32,5	55,3	45,0	82,6	408	0,85
	3-2	32,5	55,3	45,0	82,6	408	0,85
	4-1	32,5	55,3	45,0	82,6	408	0,85
	4-2	32,5	55,3	45,0	82,6	408	0,85
850	1-1	25,6	44,0	36,1	65,4	310	0,84
	1-2	25,6	44,0	36,1	65,4	310	0,84
	2-1	32,5	55,3	45,0	82,6	408	0,84
	2-2	32,5	55,3	45,0	82,6	408	0,84
	3-1	32,5	55,3	45,0	82,6	408	0,84
	3-2	32,5	55,3	45,0	82,6	408	0,84
	4-1	32,5	55,3	45,0	82,6	408	0,85
	4-2	32,5	55,3	45,0	82,6	408	0,85
900	1-1	32,5	55,3	45,0	82,6	408	0,85
	1-2	32,5	55,3	45,0	82,6	408	0,84
	2-1	32,5	55,3	45,0	82,6	408	0,84
	2-2	32,5	55,3	45,0	82,6	408	0,84
	3-1	32,5	55,3	45,0	82,6	408	0,85
	3-2	32,5	55,3	45,0	82,6	408	0,85
	4-1	32,5	55,3	45,0	82,6	408	0,85
	4-2	32,5	55,3	45,0	82,6	408	0,85

8 - Technical Data (continued)

Fans electrical data CO units units 400V/3ph/50Hz

Model	Number of fans	Nominal input power / fan	Nominal input current / fan	Total input power / fan	Total input current / fan
SYSCROLL AIR EVO CO / TR _version		kW	A	kW	A
400	8	1,9	3,9	15,2	31,2
450	10	1,9	3,9	19,0	39,0
490	11	1,9	3,9	20,9	42,9
530	12	1,9	3,9	22,8	46,8
600	13	1,9	3,9	24,7	50,7
670	14	1,9	3,9	26,6	54,6
750	16	1,9	3,9	30,4	62,4
800	16	1,9	3,9	30,4	62,4
850	18	1,9	3,9	34,2	70,2
900	20	1,9	3,9	38,0	78,0

Model	Number of fans	Nominal input power / fan	Nominal input current / fan	Total input power / fan	Total input current / fan
SYSCROLL AIR EVO CO / TR EC version		kW	A	kW	A
400	8	2,0	3,3	15,6	26,4
450	10	2,0	3,3	19,5	33,0
490	11	2,0	3,3	21,5	36,3
530	12	2,0	3,3	23,4	39,6
600	13	2,0	3,3	25,4	42,9
670	14	2,0	3,3	27,3	46,2
750	16	2,0	3,3	31,2	52,8
800	16	2,0	3,3	31,2	52,8
850	18	2,0	3,3	35,1	59,4
900	20	2,0	3,3	39,0	66,0

Model	Number of fans	Nominal input power / fan	Nominal input current / fan	Total input power / fan	Total input current / fan
SYSCROLL AIR EVO CO / TR HPF version		kW	A	kW	A
400	8	3,1	4,8	24,8	38,4
450	10	3,1	4,8	31,0	48,0
490	11	3,1	4,8	34,1	52,8
530	12	3,1	4,8	37,2	57,6
600	13	3,1	4,8	40,3	62,4
670	14	3,1	4,8	43,4	67,2
750	16	3,1	4,8	49,6	76,8
800	16	3,1	4,8	49,6	76,8
850	18	3,1	4,8	55,8	86,4
900	20	3,1	4,8	62,0	96,0

8 - Technical Data (continued)

Fans electrical data CO units units 400V/3ph/50Hz (continued)

Model	Number of fans	Nominal input power / fan	Nominal input current / fan	Total input power / fan	Total input current / fan
SYSCROLL AIR EVO CO / TR S version		kW	A	kW	A
400	10	1,1	2,0	11,0	20,0
450	12	1,1	2,0	13,2	24,0
490	13	1,1	2,0	14,3	26,0
530	14	1,1	2,0	15,4	28,0
600	15	1,1	2,0	16,5	30,0
670	16	1,1	2,0	17,6	32,0
750	20	1,1	2,0	22,0	40,0
800	20	1,1	2,0	22,0	40,0
850	22	1,1	2,0	24,2	44,0

Model	Number of fans	Nominal input power / fan	Nominal input current / fan	Total input power / fan	Total input current / fan
SYSCROLL AIR EVO CO / TR EC S version		kW	A	kW	A
400	10	2,0	3,3	19,5	33,0
450	12	2,0	3,3	23,4	39,6
490	13	2,0	3,3	25,4	42,9
530	14	2,0	3,3	27,3	46,2
600	15	2,0	3,3	29,3	49,5
670	16	2,0	3,3	31,2	52,8
750	20	2,0	3,3	39,0	66,0
800	20	2,0	3,3	39,0	66,0
850	22	2,0	3,3	42,9	72,6

Model	Number of fans	Nominal input power / fan	Nominal input current / fan	Total input power / fan	Total input current / fan
SYSCROLL AIR EVO CO HT		kW	A	kW	A
400	10	3,1	4,8	31,0	48,0
450	12	3,1	4,8	37,2	57,6
490	13	3,1	4,8	40,3	62,4
530	14	3,1	4,8	43,4	67,2
600	15	3,1	4,8	46,5	72,0
670	16	3,1	4,8	49,6	76,8
750	20	3,1	4,8	62,0	96,0
800	20	3,1	4,8	62,0	96,0
850	22	3,1	4,8	68,2	105,6

8 - Technical Data (continued)

Fans electrical data HP units units 400V/3ph/50Hz

Model	Number of fans	Nominal input power / fan	Nominal input current / fan	Total input power / fan	Total input current / fan
SYSCROLL AIR EVO HP _version		kW	A	kW	A
400	9	1,9	3,9	17,1	35,1
450	10	1,9	3,9	19,0	39,0
490	11	1,9	3,9	20,9	42,9
530	12	1,9	3,9	22,8	46,8
580	14	1,9	3,9	26,6	54,6
620	15	1,9	3,9	28,5	58,5
670	16	1,9	3,9	30,4	62,4
750	17	1,9	3,9	32,3	66,3
800	18	1,9	3,9	34,2	70,2
850	19	1,9	3,9	36,1	74,1
900	20	1,9	3,9	38,0	78,0

Model	Number of fans	Nominal input power / fan	Nominal input current / fan	Total input power / fan	Total input current / fan
SYSCROLL AIR EVO HP EC version		kW	A	kW	A
400	9	2,0	3,3	17,6	29,7
450	10	2,0	3,3	19,5	33,0
490	11	2,0	3,3	21,5	36,3
530	12	2,0	3,3	23,4	39,6
580	14	2,0	3,3	27,3	46,2
620	15	2,0	3,3	29,3	49,5
670	16	2,0	3,3	31,2	52,8
750	17	2,0	3,3	33,2	56,1
800	18	2,0	3,3	35,1	59,4
850	19	2,0	3,3	37,1	62,7
900	20	2,0	3,3	39,0	66,0

Model	Number of fans	Nominal input power / fan	Nominal input current / fan	Total input power / fan	Total input current / fan
SYSCROLL AIR EVO HP HPF version		kW	A	kW	A
400	9	3,1	4,8	27,9	43,2
450	10	3,1	4,8	31,0	48,0
490	11	3,1	4,8	34,1	52,8
530	12	3,1	4,8	37,2	57,6
580	14	3,1	4,8	43,4	67,2
620	15	3,1	4,8	46,5	72,0
670	16	3,1	4,8	49,6	76,8
750	17	3,1	4,8	52,7	81,6
800	18	3,1	4,8	55,8	86,4
850	19	3,1	4,8	58,9	91,2
900	20	3,1	4,8	62,0	96,0

8 - Technical Data (continued)

Fans electrical data HP units units 400V/3ph/50Hz (continued)

Model	Number of fans	Nominal input power / fan	Nominal input current / fan	Total input power / fan	Total input current / fan
SYSCROLL AIR EVO HP S version		kW	A	kW	A
400	11	1,1	2,0	12,1	22,0
450	12	1,1	2,0	13,2	24,0
490	13	1,1	2,0	14,3	26,0
530	14	1,1	2,0	15,4	28,0
580	16	1,1	2,0	17,6	32,0
620	17	1,1	2,0	18,7	34,0
670	18	1,1	2,0	19,8	36,0
750	21	1,1	2,0	23,1	42,0
800	22	1,1	2,0	24,2	44,0

Model	Number of fans	Nominal input power / fan	Nominal input current / fan	Total input power / fan	Total input current / fan
SYSCROLL AIR EVO HP EC S version		kW	A	kW	A
400	11	2,0	3,3	21,5	36,3
450	12	2,0	3,3	23,4	39,6
490	13	2,0	3,3	25,4	42,9
530	14	2,0	3,3	27,3	46,2
580	16	2,0	3,3	31,2	52,8
620	17	2,0	3,3	33,2	56,1
670	18	2,0	3,3	35,1	59,4
750	21	2,0	3,3	41,0	69,3
800	22	2,0	3,3	42,9	72,6

8 - Technical Data (continued)

8.4 Hydraulic features

Evaporator Water Pressure Drop Curves - SYSCROLL AIR EVO CO

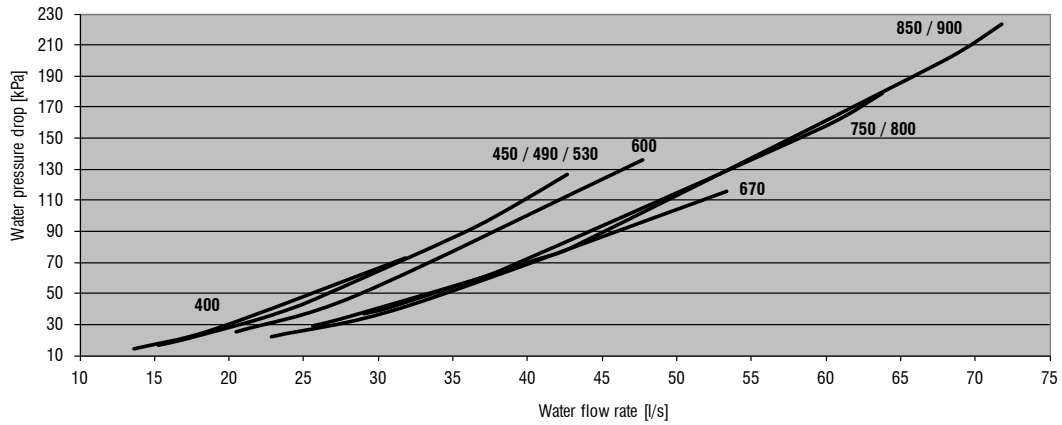

Evaporator Water Pressure Drop Curves - SYSCROLL AIR EVO HP

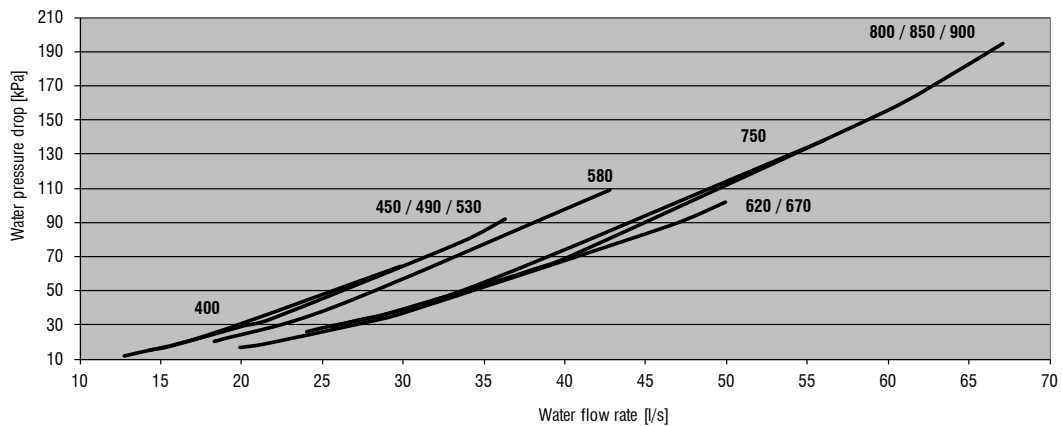

Condenser Water Pressure Drop Curves - SYSCROLL AIR EVO HP

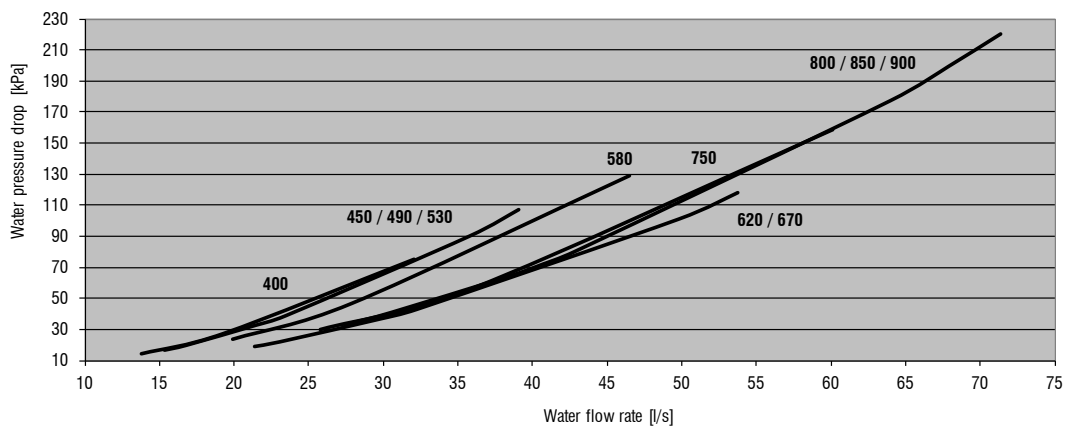

8 - Technical Data (continued)

Condenser Water Pressure Drop Curves - SYSCROLL AIR EVO TR

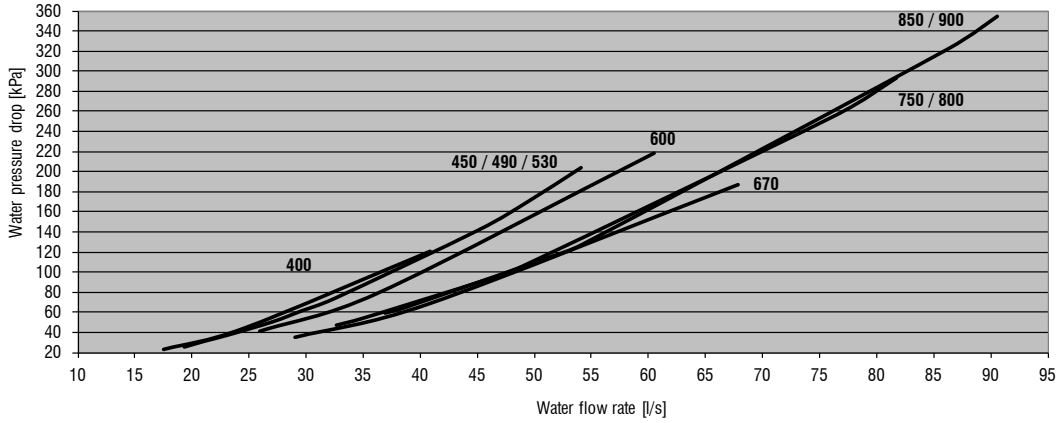

Pump available static pressure - SYSCROLL 400 AIR EVO CO/HP

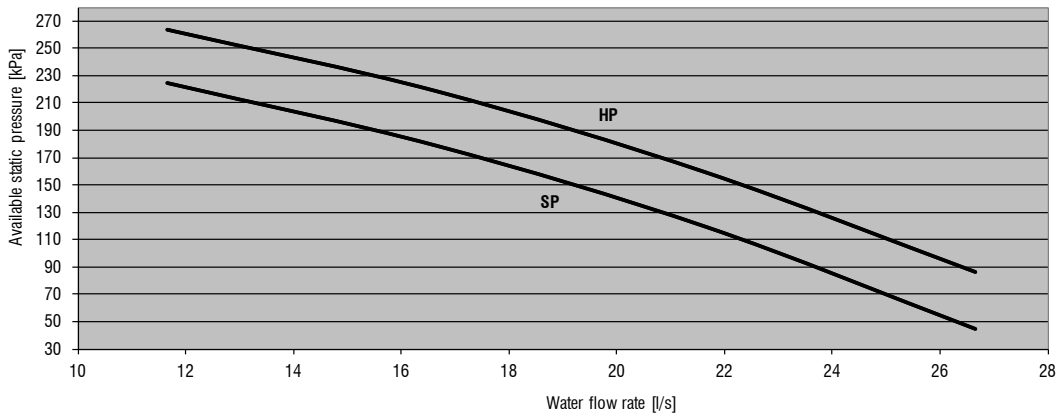

Pump available static pressure - SYSCROLL 450 AIR EVO CO/HP

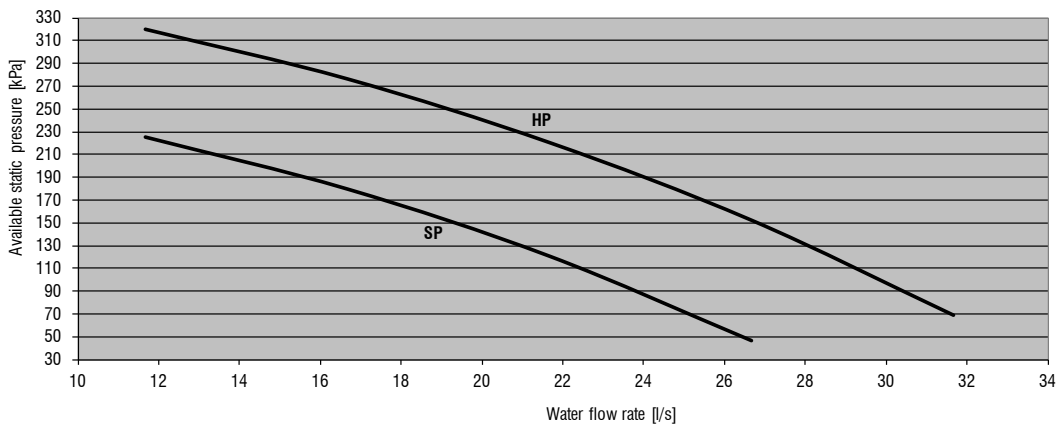

8 - Technical Data (continued)

8.4.1 Variable flow hydronic systems

• Manual flow control

1. Application

Provide the user with the required flow rate and hydraulic balance without the need of mechanical balancing valve but taking advantage of the energy consumption optimization of the pump using the frequency drive.

2. Description

SYSCROLL 400-900 AIR EVO is equipped with hydraulic module driven by frequency drive that does not provide continuous modulation of the pump speed but a fixed water flow rate during commissioning.

3. Operation

The pump motor speed limits must be set during the chiller commissioning and in accordance with below rules:

- Pump speed high limit should be referenced to the Nominal Water Flow Rate
- Pump speed low limit should be referenced to the Minimum Water Flow Rate

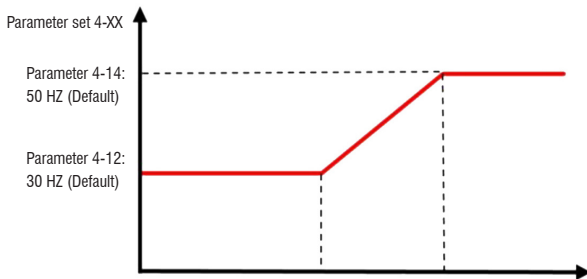

IMAGE 01: Frequency vs Speed behavior

[Hand On] enables control of the frequency converter via the LCP. **[Hand On]** also starts the motor and allows entering the required motor frequency with the navigation keys [▲]/ [▼].

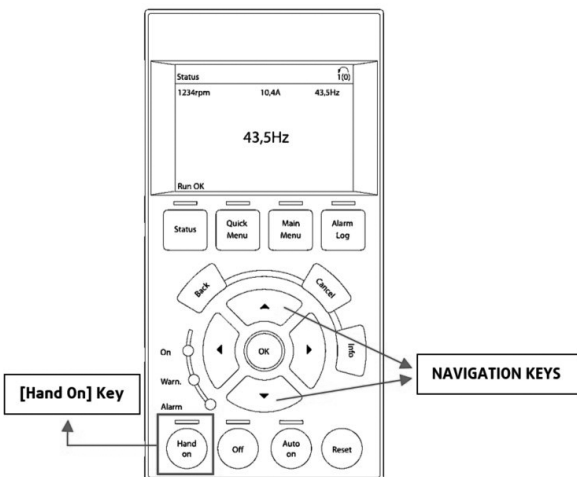

IMAGE 02: LCP DISPLAY

Note: When VPF works at 30 Hz, the absorbed power consumption of the pump is reduced by 80% compared to 50Hz pump operation.

• Variable primary flow (Constant ΔP)

1. Application

This option is recommendable on installations with two-way valves on the customer water loop. This method ensures that each branch of the water loop has a uniform water supply without unnecessary energy consumption.

2. Description

For this option, the unit is equipped with a hydraulic module driven by frequency drive. The modulation of the pump speed ensures that the Differential Pressure (DP) remains constant within the system. At minimum partial loads, the minimum flow across the chiller evaporator should be ensured or a by-pass valve should be installed to prevent the evaporator from low flow, which otherwise is very critical to the chiller system.

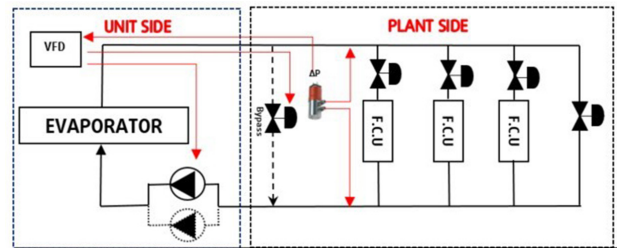

IMAGE 03: Constant ΔP Control diagram

Note: In two-pump configuration, there is an alternation of the pump operation for every 12 hrs.

Note: For the electrical connection of differential pressure transducer, pressure transducers and By-pass valve, refer electrical drawings of the hydraulic module.

3. Operation

Delta pressure is measured by 1 pressure sensor. The modulation control logic PI of the pump speed starts as soon as pump is in operation in accordance with DP set point fixed on VFD controller. If the load decreases, the control valves are closed and that increases the Delta P, then the speed of the pump is decreased in order to decrease the Delta P until the setpoint. (Decreasing the speed to the half, decreases consumption by 90%).

8 - Technical Data (continued)

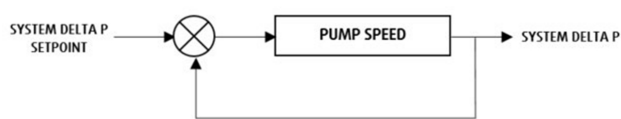
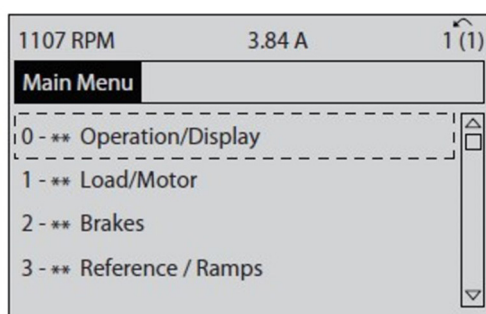

IMAGE 04: Control logic

By default, VFD is programmed to operate at **[Auto On]** mode. Customer can change the **SETPOINT** by following the below mentioned instructions:

Press **[Main Menu]** to select the Main Menu mode. The below read out appears on the display. The bottom section on the display shows a list of parameter groups, select Parameter 20-xx Drive Closed Loop which can be selected by toggling the **[▲]** and **[▼]** keys and then select 20-21 Setpoint 1 and change the value of default setpoint by **[▲]** and **[▼]** keys.



IMPORTANT! The differential pressure transducer, the pressure transducers and the By-pass valve are supplied loose at customer charge. Systemair provides only indications for the plant design with respect to the minimum water flow on the primary heat exchanger.

• Variable primary flow (Constant ΔT)

1. Application

This option is to provide a flow rate in order to maintain constant the delta between the inlet and outlet temperatures of the chiller. This option is to be implemented on the water loops with two or three way valves and can deliver higher energy saving compared to constant DP in the majority of the comfort applications.

2. Description

With this option, **SYSCROLL 400-900 AIR EVO** chillers will be equipped with a hydraulic module driven by a frequency drive, the modulation of the pump speed is to ensure that the DT across the water loop is constant. At minimum partial loads, the minimum flow across the chiller evaporator should be ensured or a by-pass valve should be installed to prevent the evaporator from low flow, which otherwise is very critical to the chiller system.

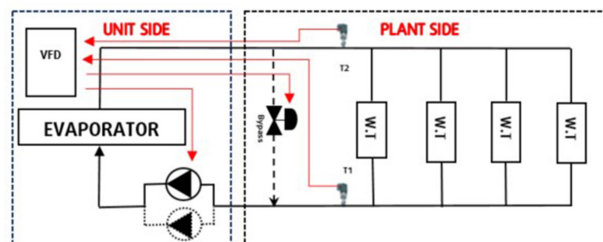

IMAGE 05: Constant ΔT Control diagram

Note: In two-pump configuration, there is an alternation of the pump operation for every 12 hrs.

Note: For the electrical connection of temperature transducers and By-pass valve, refer to electrical drawings of the hydraulic module.

3. Operation

The Entering and leaving temperatures across the chiller are measured directly by the frequency drive controller, through the factory supplied temperature transmitters. A Delta T set point will be preset on the unit controller of the frequency drive ($\Delta T=5$ by default).

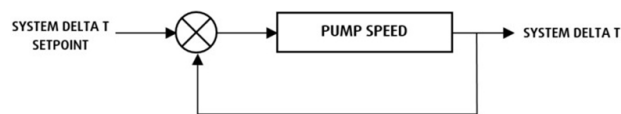
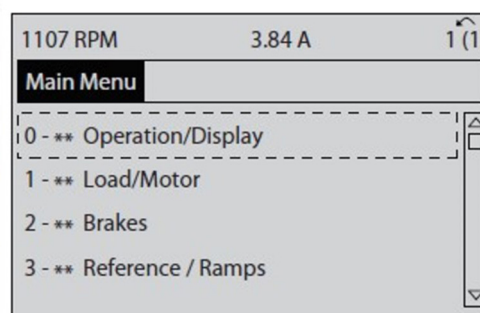

IMAGE 06: Control logic

By default, VFD is programmed to operate at **[Auto On]** mode. Customer can change the **SETPOINT** by following the below mentioned instructions:

Press **[Main Menu]** to select the Main Menu mode. The below read out appears on the display. The bottom section on the display shows a list of parameter groups, select Parameter 20-xx Drive Closed Loop which can be selected by toggling the **[▲]** and **[▼]** keys and then select 20-21 Setpoint 1 and change the value of the default setpoint of '5' by **[▲]** and **[▼]** keys.



IMPORTANT! The temperature transmitters and By-pass valve are supplied loose at customer charge. Systemair provides only indications for the plant design with respect to the minimum water flow on the primary heat exchanger.

8 - Technical Data (continued)

Available pressure head - SYSCROLL AIR EVO CO/HP Standard pressure pump (1/2PSP)

SYSCROLL 400 AIR EVO CO / HP

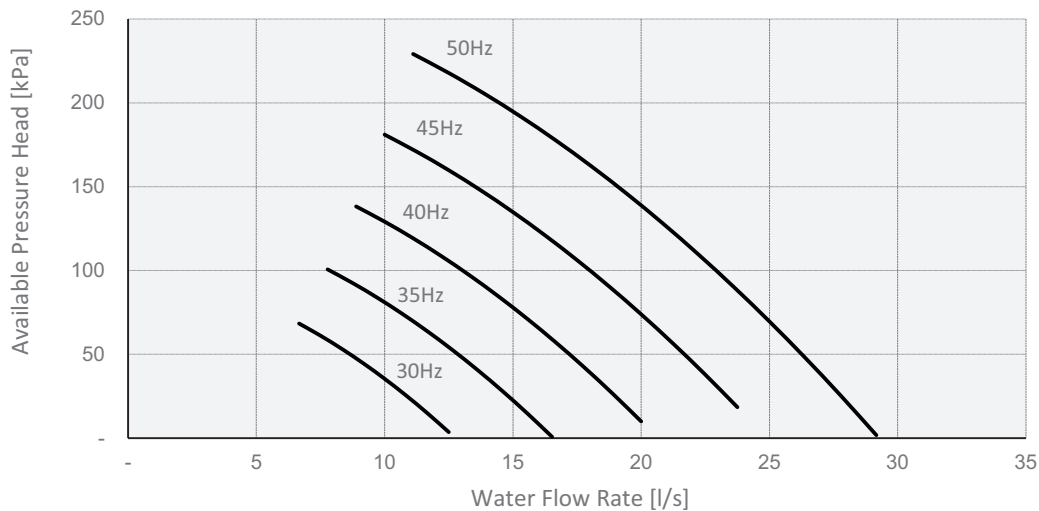

SYSCROLL 450 AIR EVO CO / HP

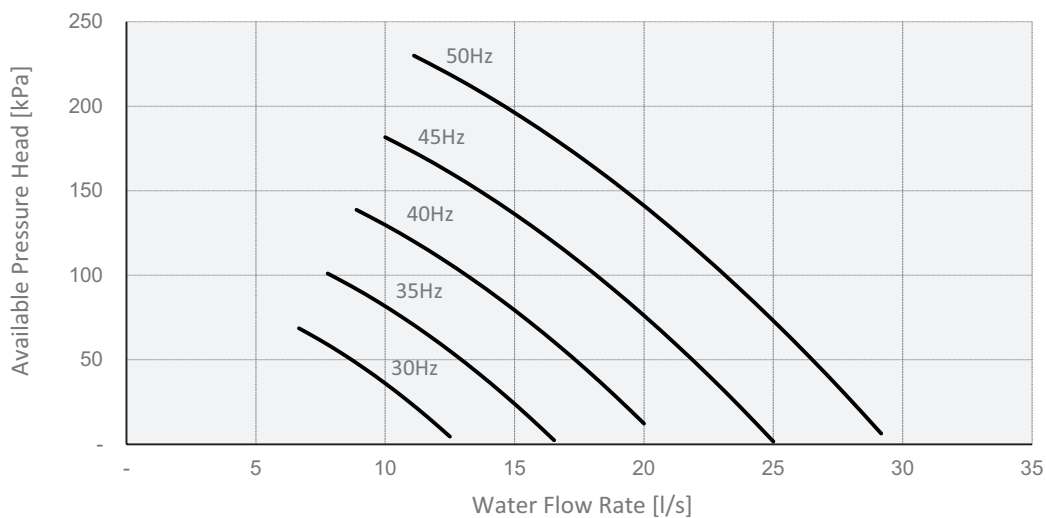

SYSCROLL 490-530 AIR EVO CO / HP

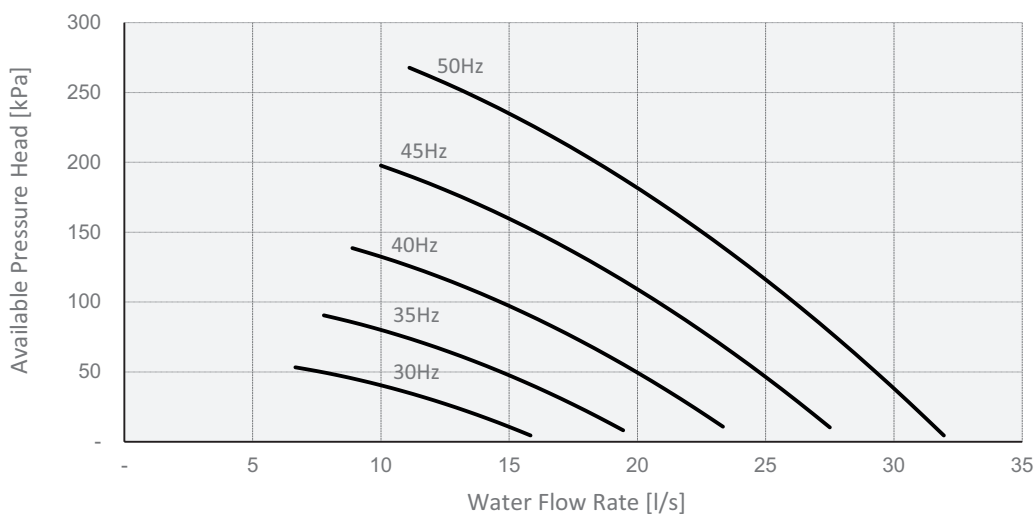

8 - Technical Data (continued)

Available pressure head - SYSCROLL AIR EVO CO/HP Standard pressure pump (1/2PSP) (continued)

SYSCROLL 580 AIR EVO HP

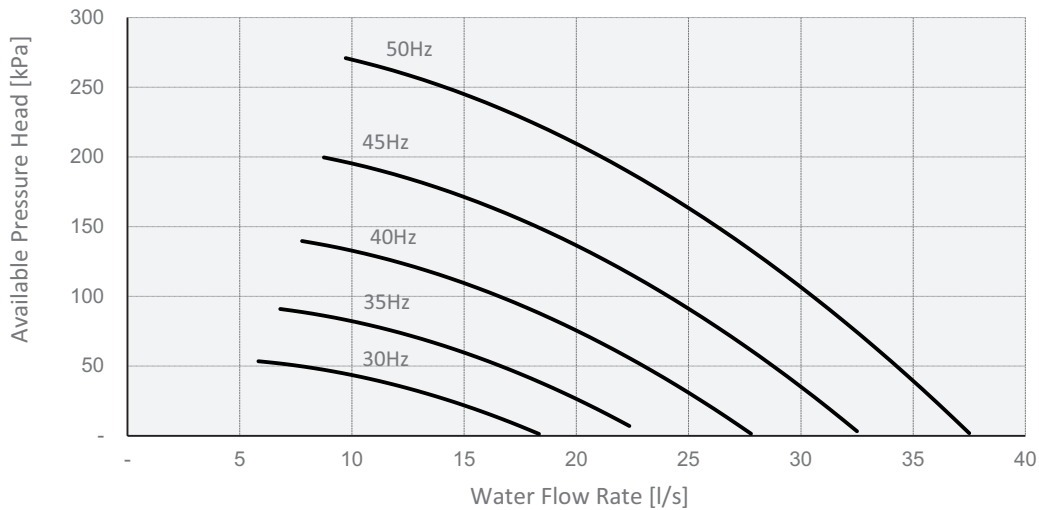

SYSCROLL 600 AIR EVO CO

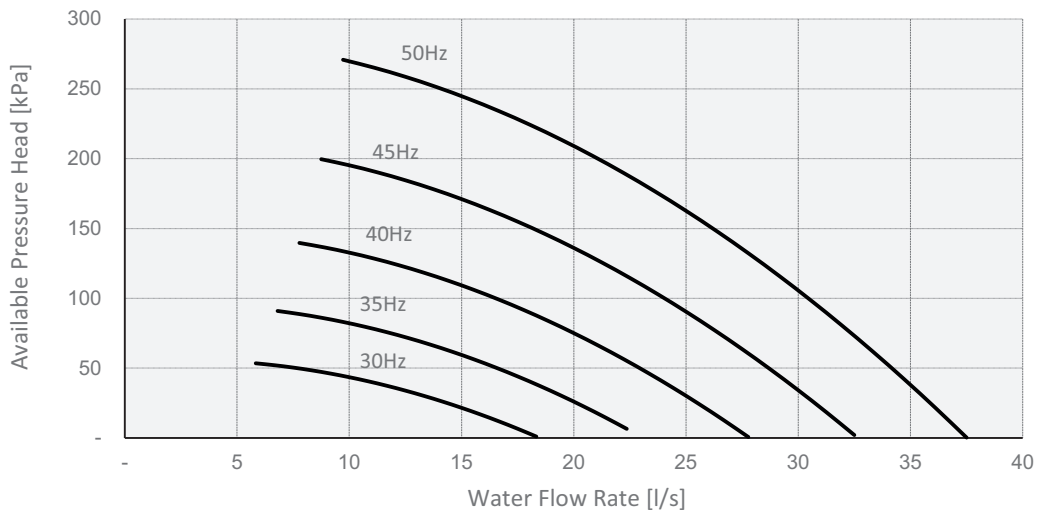

SYSCROLL 620 AIR EVO HP

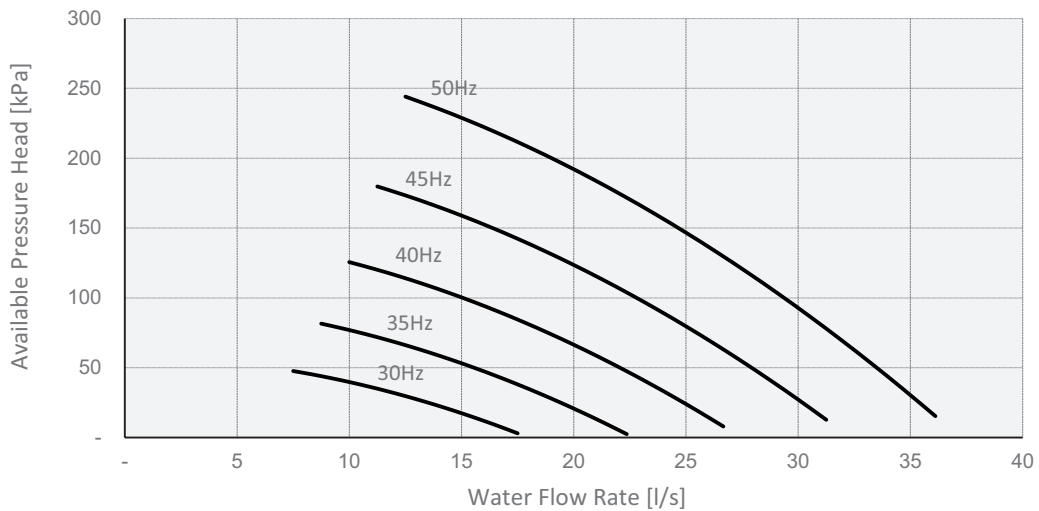

8 - Technical Data (continued)

Available pressure head - SYSCROLL AIR EVO CO/HP Standard pressure pump (1/2PSP) (continued)

SYSCROLL 670 AIR EVO CO / HP

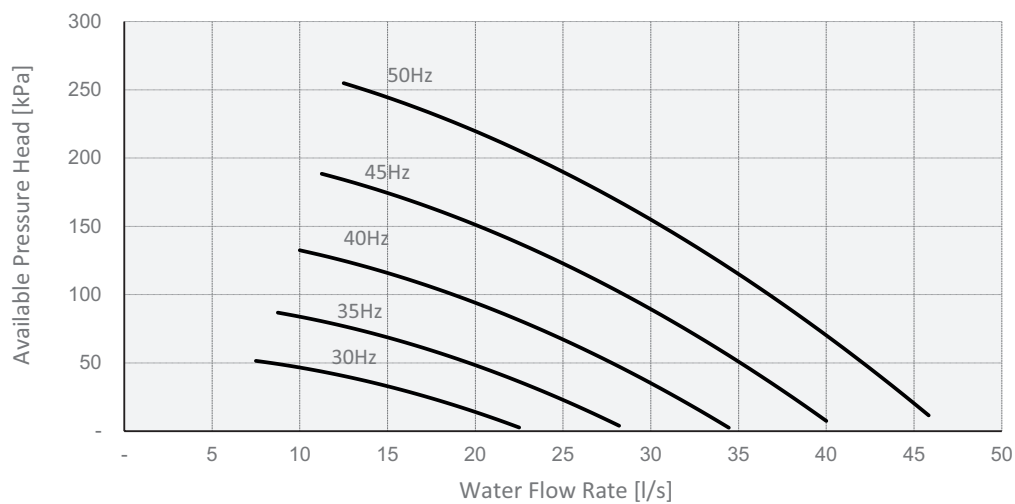

8 - Technical Data (continued)

Available pressure head - SYSCROLL AIR EVO CO/HP High pressure pump (1/2PHP)

SYSCROLL 400 AIR EVO CO / HP

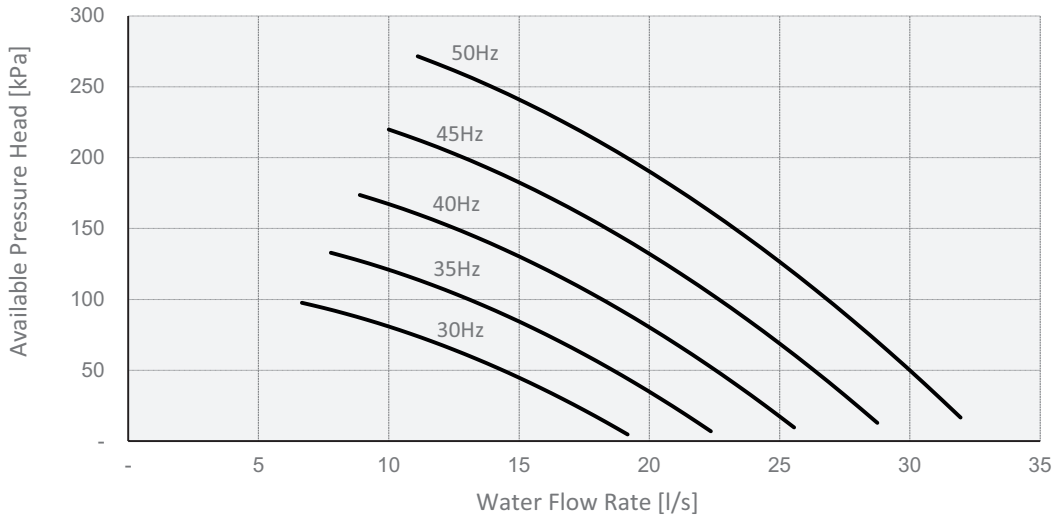

SYSCROLL 450 AIR EVO CO / HP

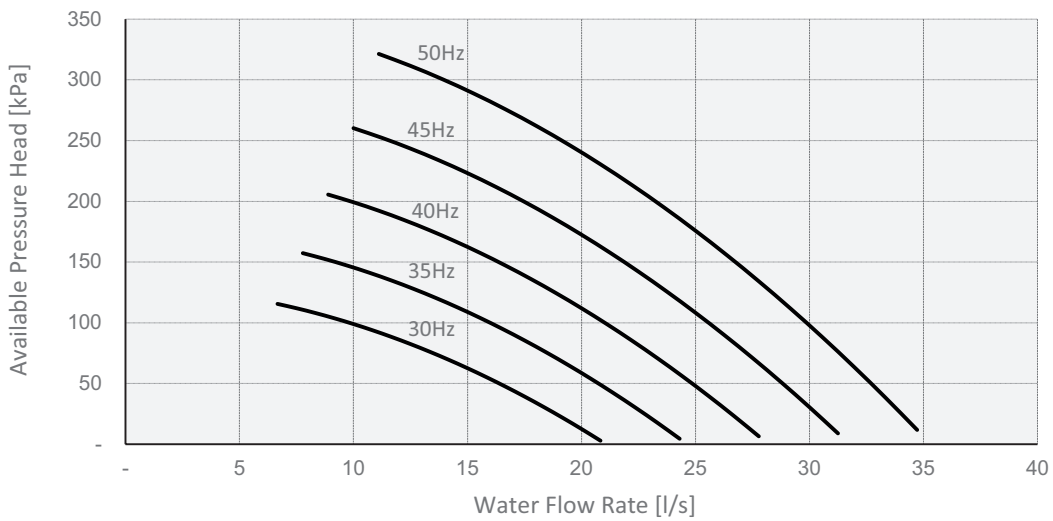

SYSCROLL 490 AIR EVO CO / HP

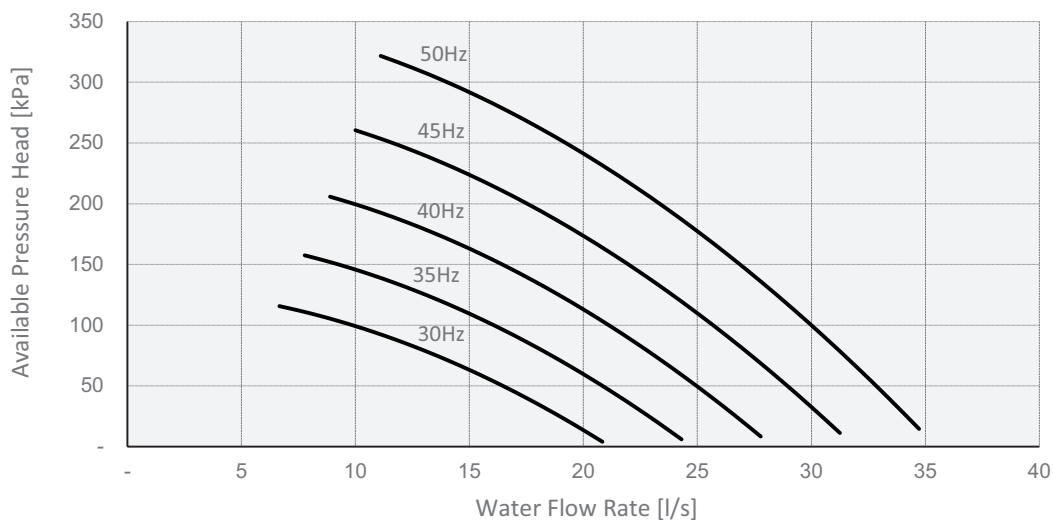

8 - Technical Data (continued)

Available pressure head - SYSCROLL AIR EVO CO/HP High pressure pump (1/2PHP) (continued)

SYSCROLL 530 AIR EVO CO / HP

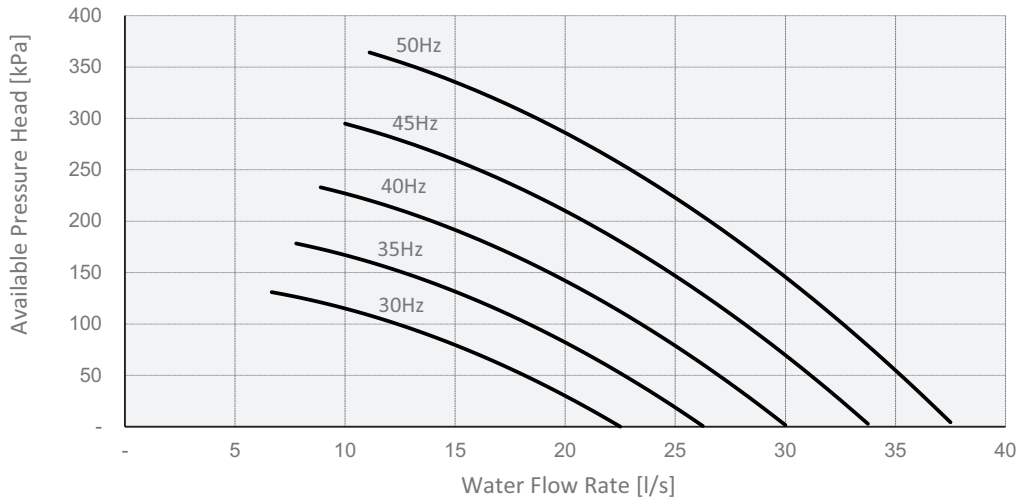

SYSCROLL 580 AIR EVO HP

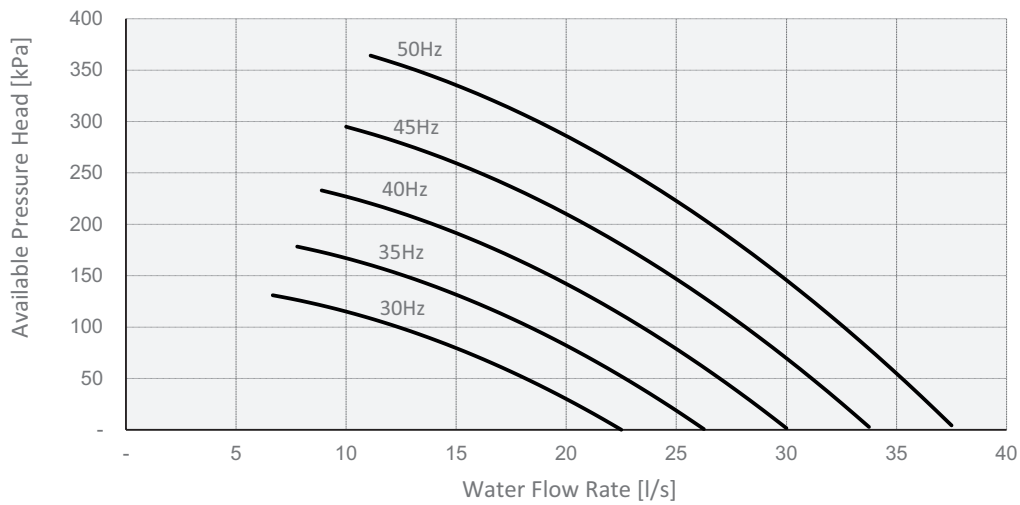

SYSCROLL 600 AIR EVO CO

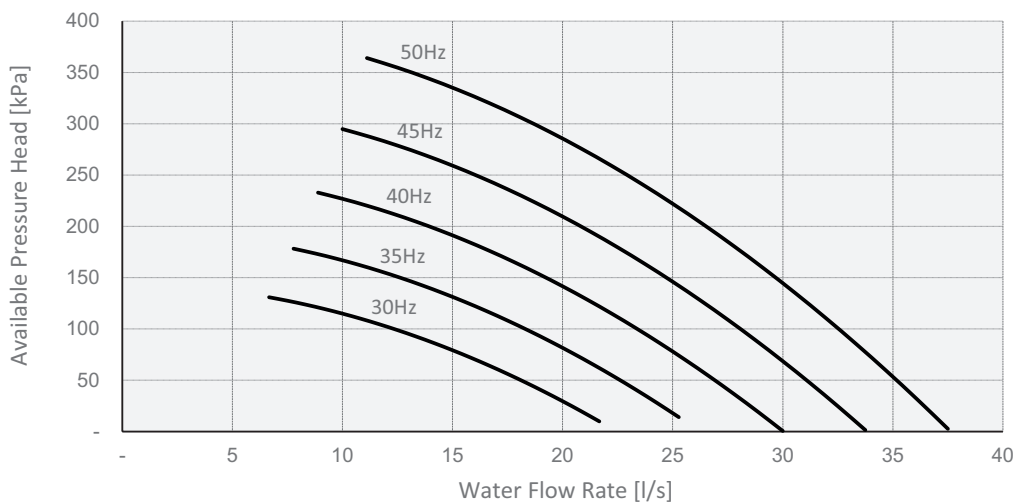

8 - Technical Data (continued)

Available pressure head - SYSCROLL AIR EVO CO/HP High pressure pump (1/2PHP) (continued)

SYSCROLL 620 AIR EVO HP

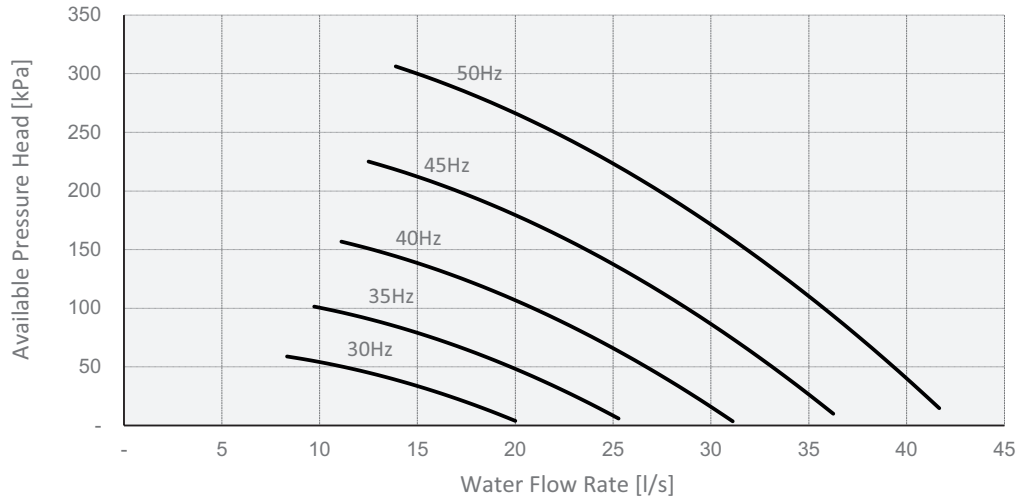

SYSCROLL 670 AIR EVO CO / HP

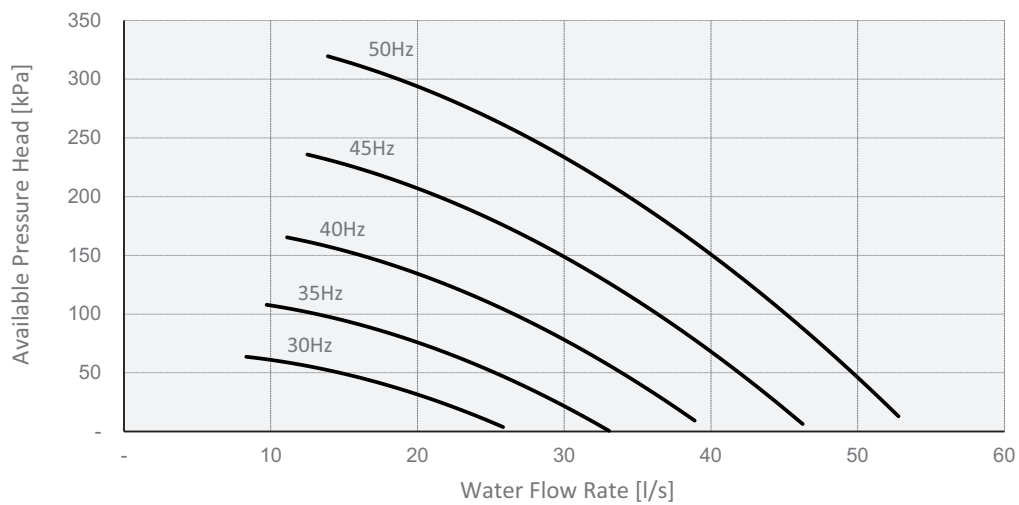

8 - Technical Data (continued)

Available pressure head- SYSCROLL 750/800 AIR EVO CO/HP

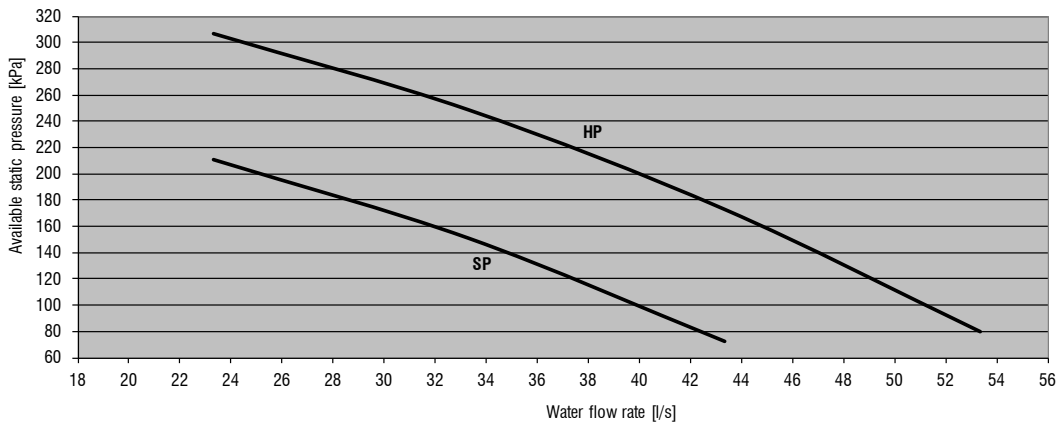

Available pressure head - SYSCROLL 850 AIR EVO CO/HP

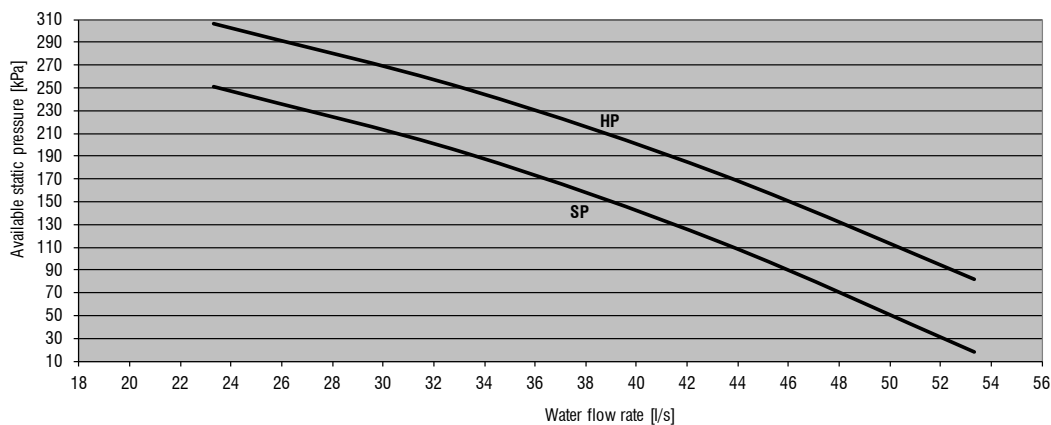

Available pressure head - SYSCROLL 900 AIR EVO CO/HP

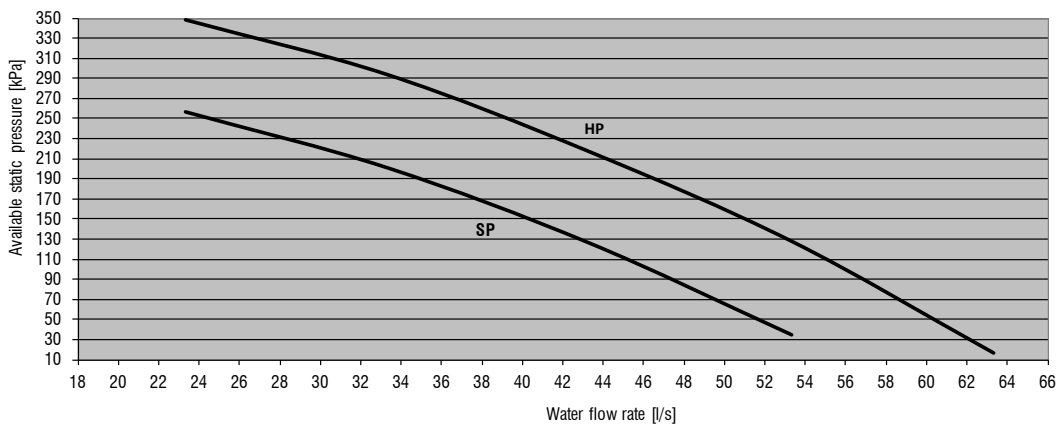

8 - Technical Data (continued)

Pump power consumption - SYSCROLL AIR EVO CO/HP Standard pressure pump (1/2PSP)

SYSCROLL 400-450 AIR EVO CO / HP

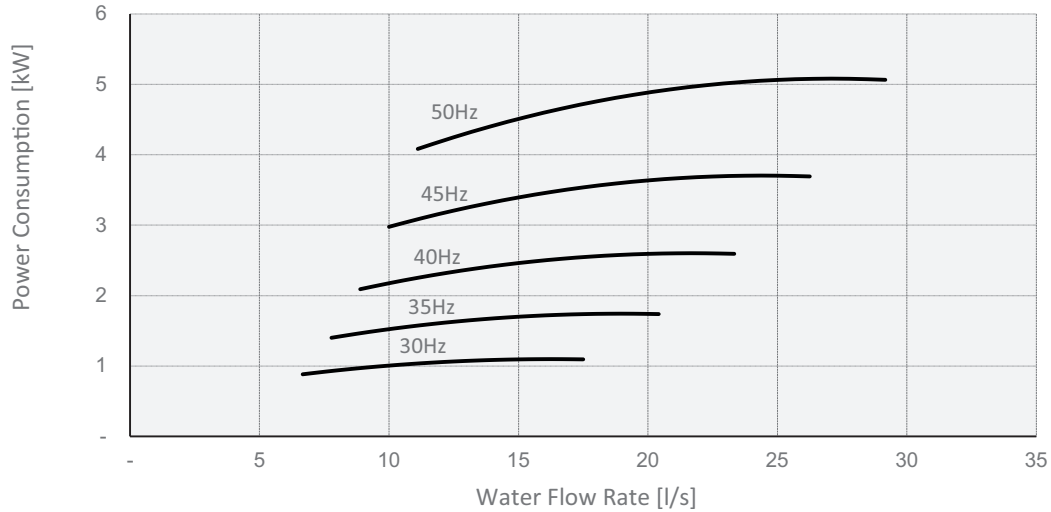

SYSCROLL 490-530 AIR EVO CO / HP

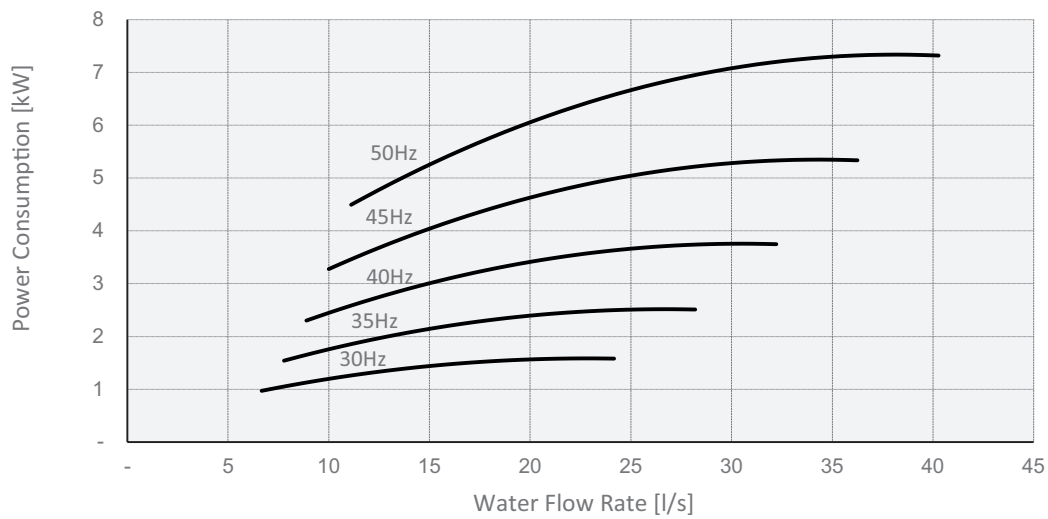

SYSCROLL 580 AIR EVO HP

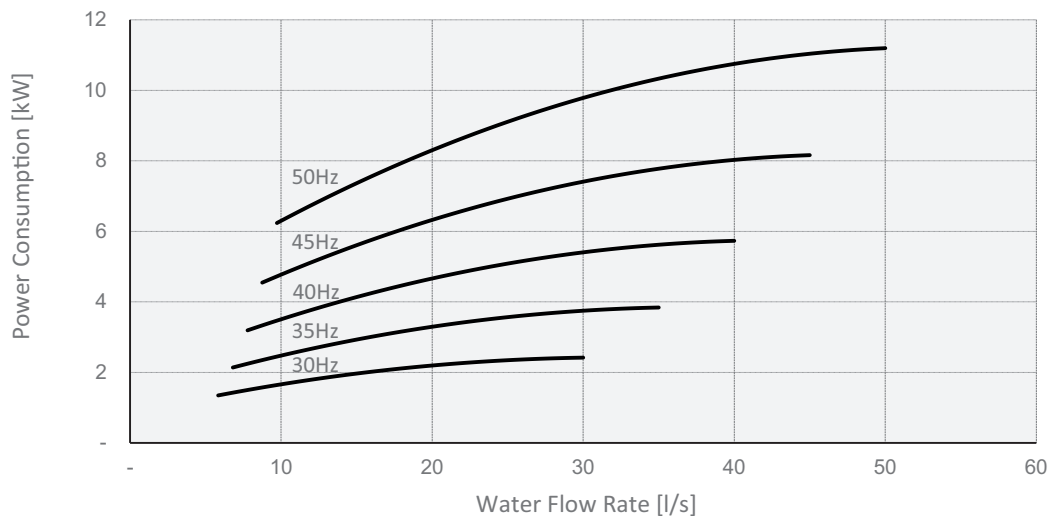

8 - Technical Data (continued)

Pump power consumption - SYSCROLL AIR EVO CO/HP Standard pressure pump (1/2PSP) (continued)

SYSCROLL 600 AIR EVO CO

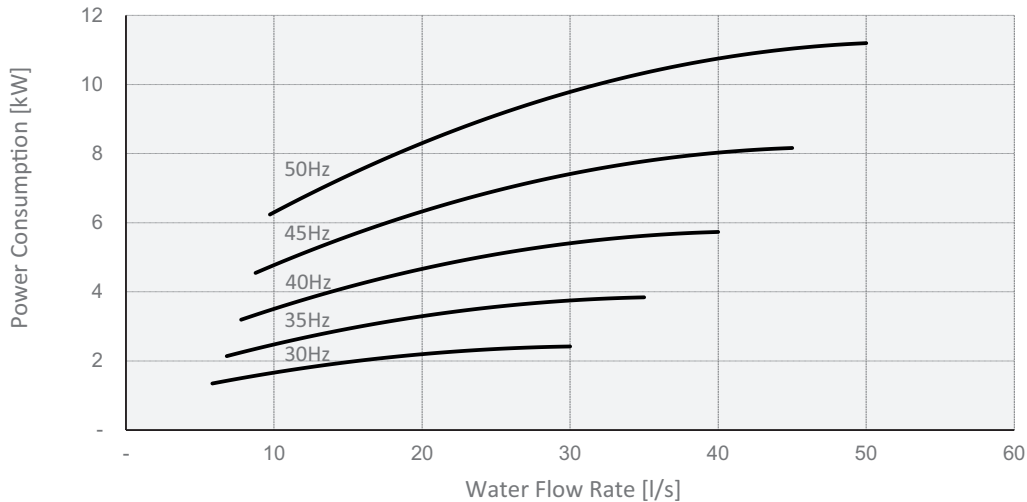

SYSCROLL 620 AIR EVO HP

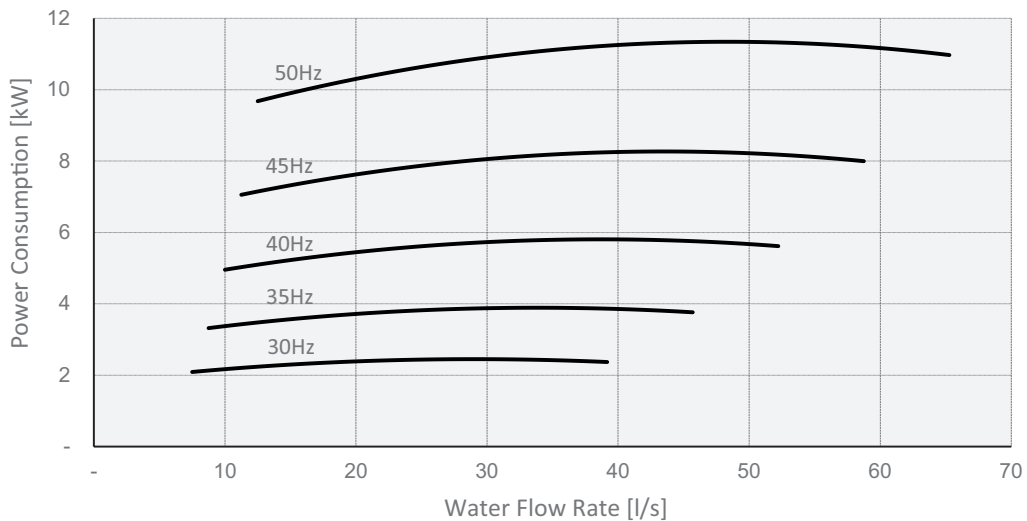

SYSCROLL 670 AIR EVO CO / HP

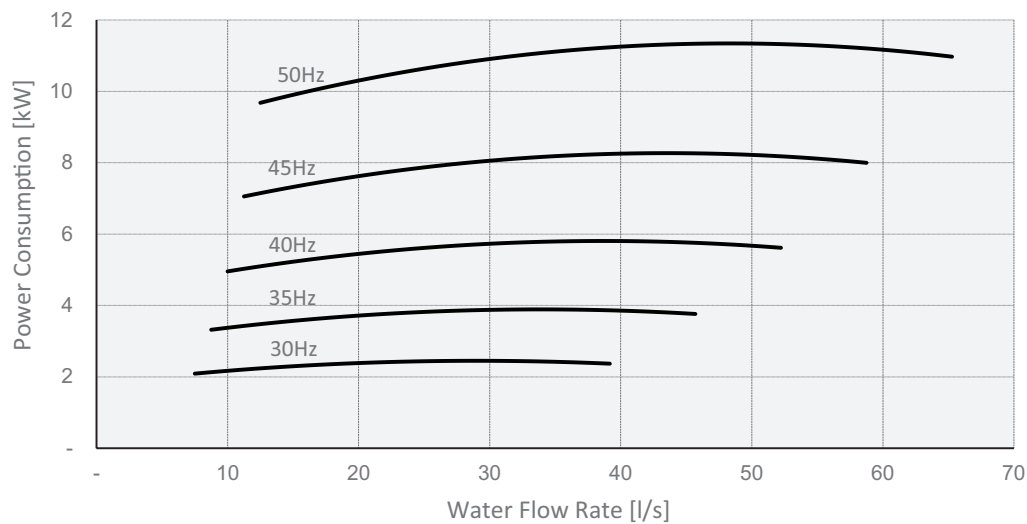

8 - Technical Data (continued)

Pump power consumption - SYSCROLL AIR EVO CO/HP High pressure pump (1/2PHP)

SYSCROLL 400 AIR EVO CO / HP

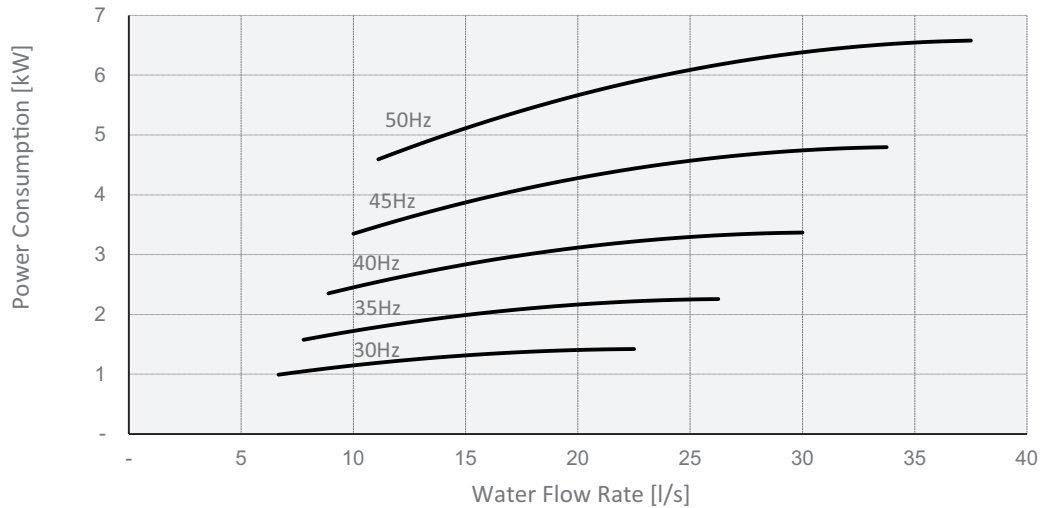

SYSCROLL 450-490 AIR EVO CO / HP

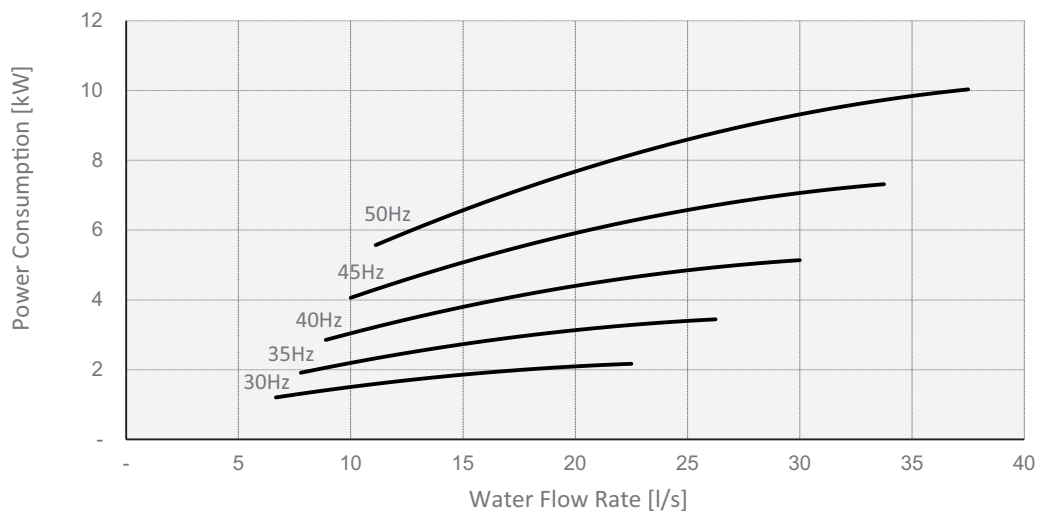

SYSCROLL 530 AIR EVO CO / HP

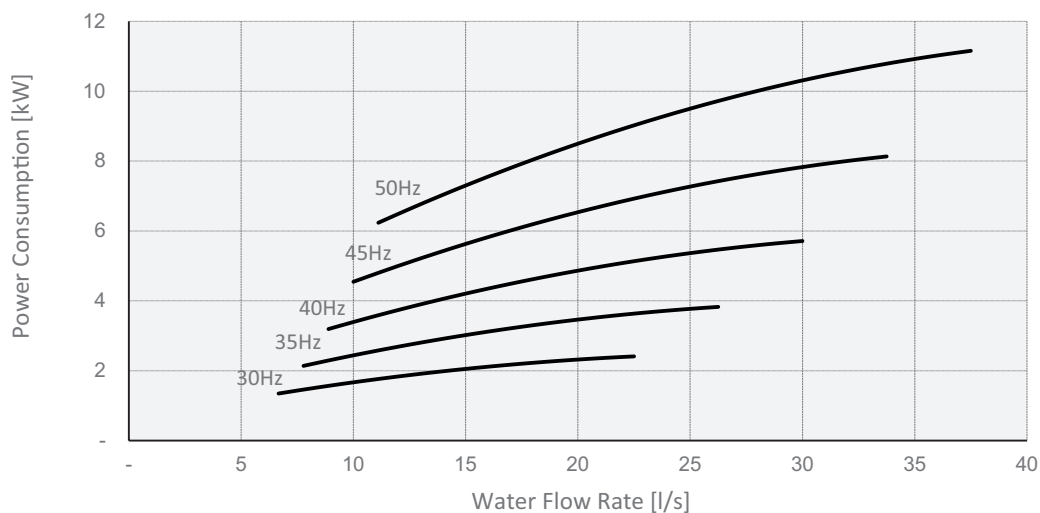

8 - Technical Data (continued)

Pump power consumption - SYSCROLL AIR EVO CO/HP High pressure pump (1/2PHP) (continued)

SYSCROLL 580 AIR EVO HP

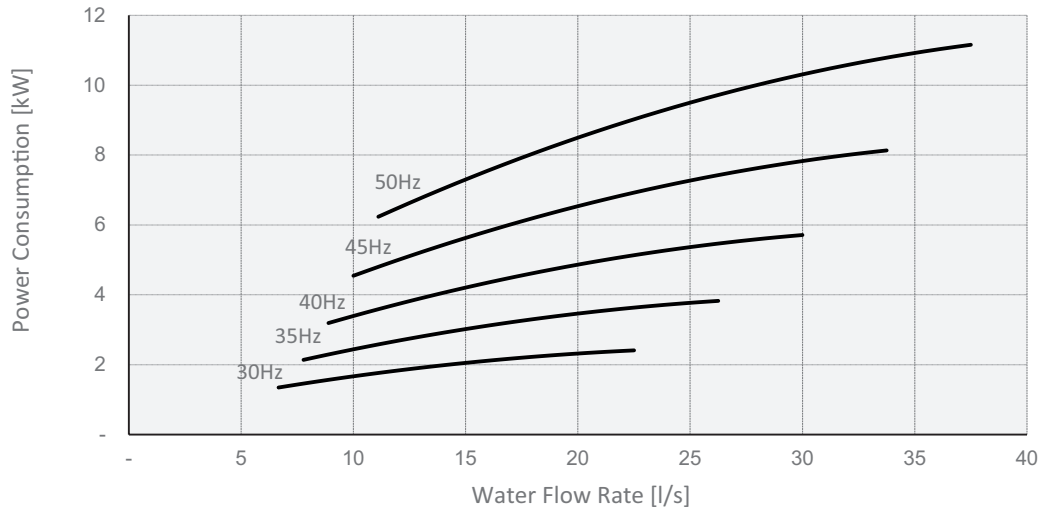

SYSCROLL 600 AIR EVO CO

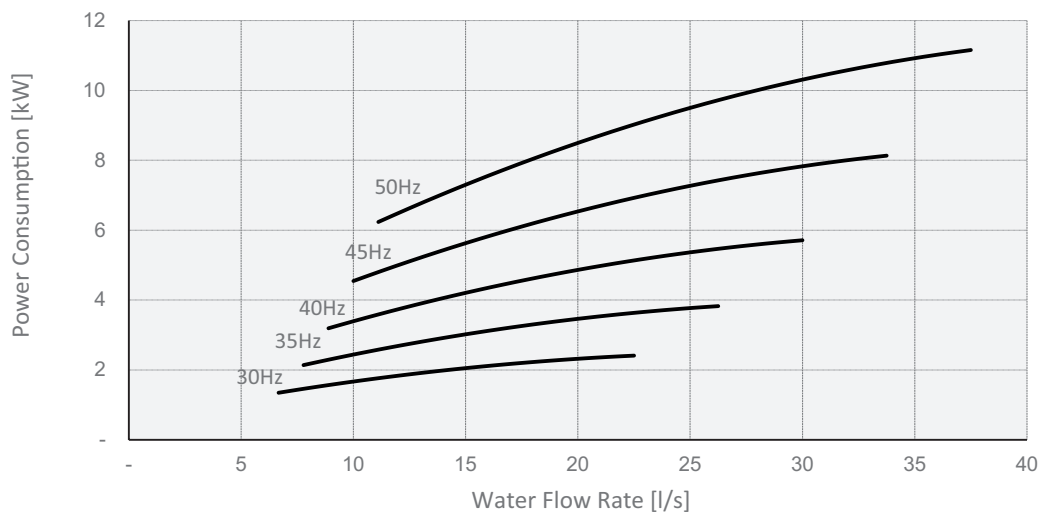

SYSCROLL 620 AIR EVO HP

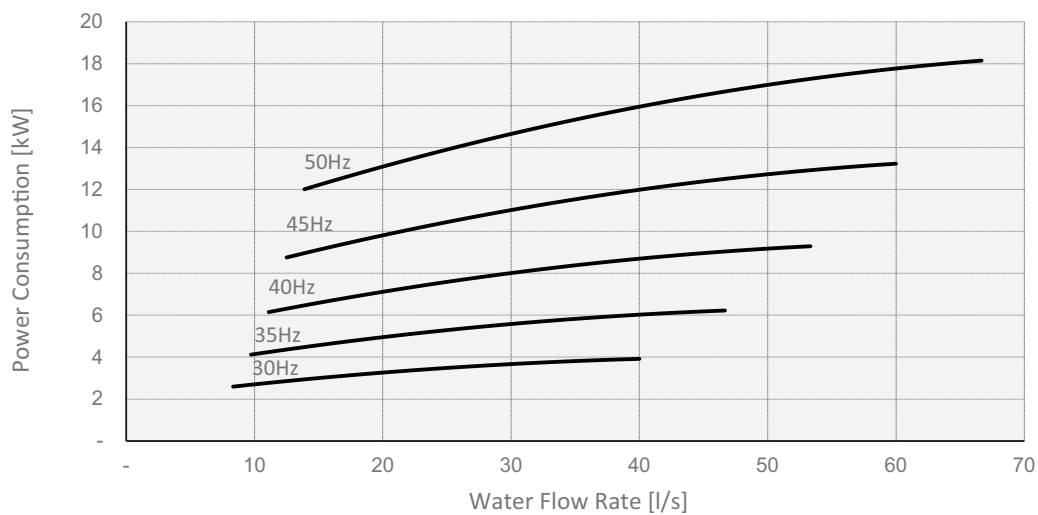

8 - Technical Data (continued)

Pump power consumption - SYSCROLL AIR EVO CO/HP High pressure pump (1/2PHP) (continued)

SYSCROLL 670 AIR EVO CO / HP

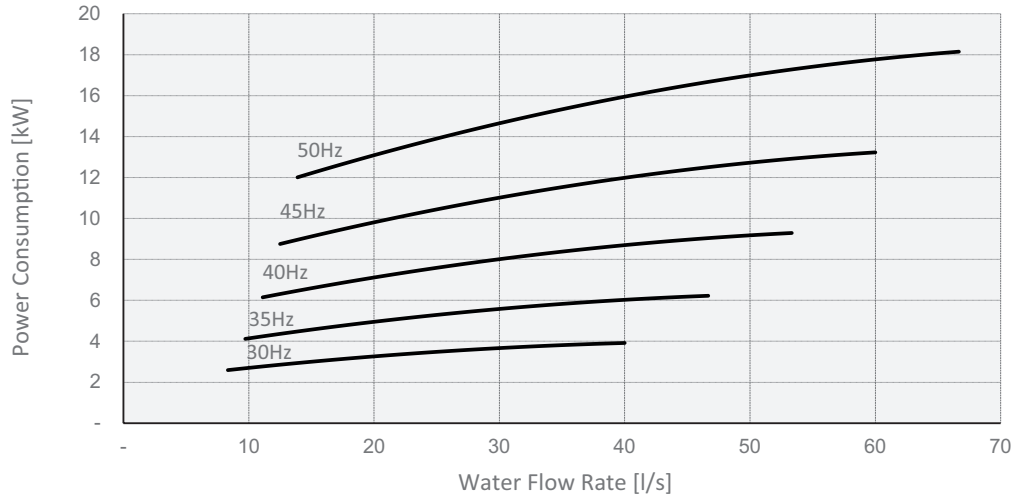

8 - Technical Data (continued)

8.5 Position of shock adsorbers and weight distribution on supports

Model	Mo- dules	Weight distribution								Opera- ting weight kg	Shipping weight kg	CG	
		P1	P2	P3	P4	P5	P6	P7	P8			x	y
		kg	kg	kg	kg	kg	kg	kg	kg			mm	mm
SYSCROLL AIR EVO 400 CO	4	589	589	925	925	-	-	-	-	3028	2930	2135	1041
SYSCROLL AIR EVO 450 CO	5	647	647	1037	1037	-	-	-	-	3367	3257	2802	1041
SYSCROLL AIR EVO 490 CO	6	255	255	457	457	514	514	666	666	3783	3673	3315	1041
SYSCROLL AIR EVO 530 CO	6	262	262	490	490	555	555	728	728	4069	3959	3346	1041
SYSCROLL AIR EVO 600 CO	7	236	236	476	476	603	603	843	843	4317	4197	4303	1041
SYSCROLL AIR EVO 670 CO	7	261	261	502	502	629	629	870	870	4524	4399	4261	1041
SYSCROLL AIR EVO 750 CO	8	368	368	595	595	784	784	1021	1021	5536	5360	4542	1041
SYSCROLL AIR EVO 800 CO	8	380	380	605	605	792	792	1026	1026	5607	5416	4520	1041
SYSCROLL AIR EVO 850 CO	9	388	388	599	599	878	878	1088	1088	5906	5703	5581	1041
SYSCROLL AIR EVO 900 CO	10	417	417	662	662	925	925	1123	1123	6253	6038	6049	1041
SYSCROLL AIR EVO 400 HP	5	740	740	1144	1144	-	-	-	-	3769	3671	2761	1041
SYSCROLL AIR EVO 450 HP	5	785	785	1184	1184	-	-	-	-	3938	3828	2734	1041
SYSCROLL AIR EVO 490 HP	6	326	326	535	535	594	594	751	751	4412	4302	3249	1041
SYSCROLL AIR EVO 530 HP	6	339	339	574	574	640	640	818	818	4744	4634	3275	1041
SYSCROLL AIR EVO 580 HP	7	323	323	583	583	721	721	981	981	5214	5094	4202	1041
SYSCROLL AIR EVO 620 HP	8	356	356	594	594	791	791	1037	1037	5554	5429	4579	1041
SYSCROLL AIR EVO 670 HP	8	372	372	610	610	808	808	1055	1055	5691	5566	4558	1041
SYSCROLL AIR EVO 750 HP	9	474	474	699	699	998	998	1224	1224	6790	6614	5499	1041
SYSCROLL AIR EVO 800 HP	9	498	498	723	723	1023	1023	1248	1248	6985	6797	5468	1041
SYSCROLL AIR EVO 850 HP	10	515	515	776	776	1057	1057	1268	1268	7231	7028	5957	1041
SYSCROLL AIR EVO 900 HP	10	538	538	798	798	1079	1079	1290	1290	7408	7193	5928	1041

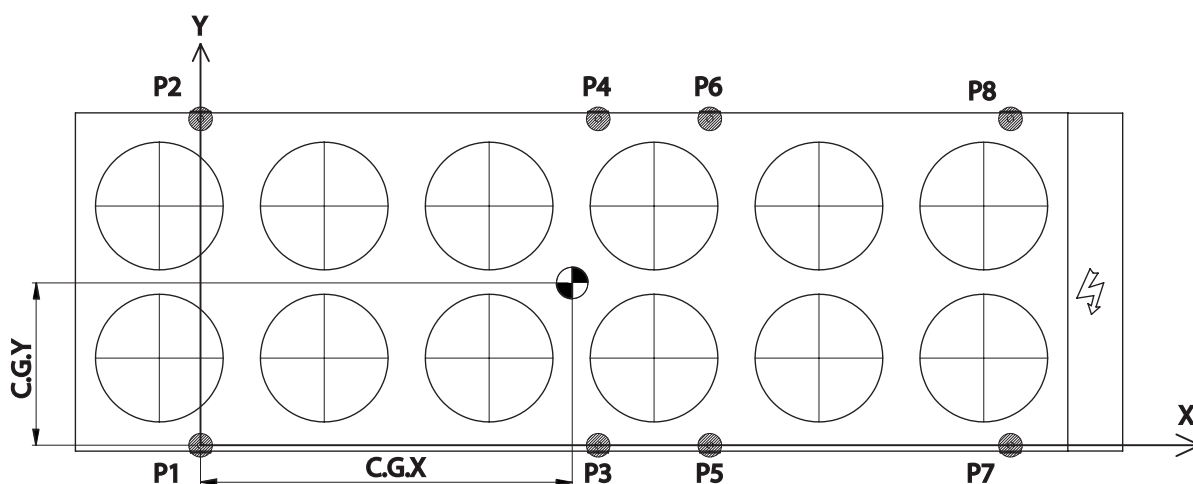
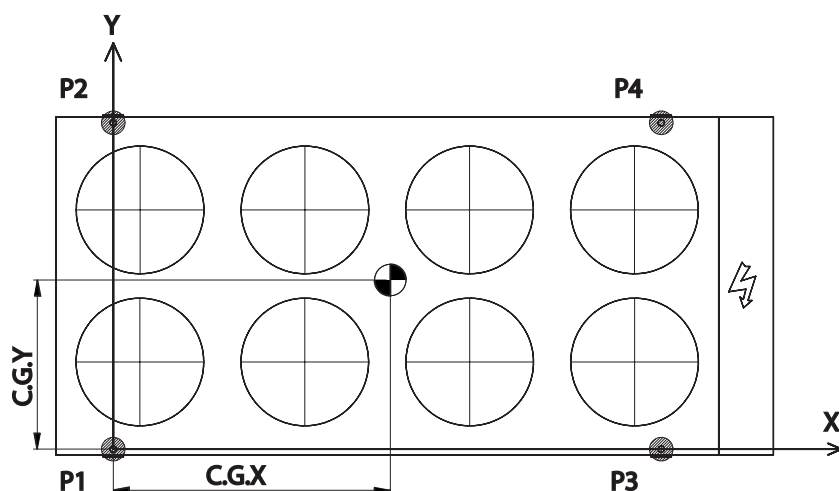

8 - Technical Data (continued)

8.6 Dimensions SYSCROLL AIR EVO 400-670

Front view

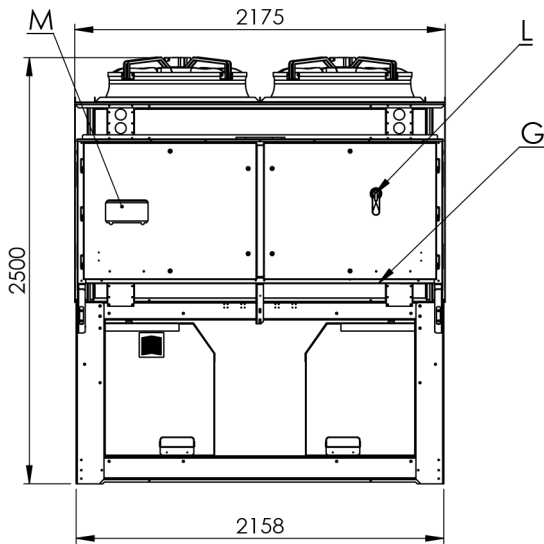

Side view

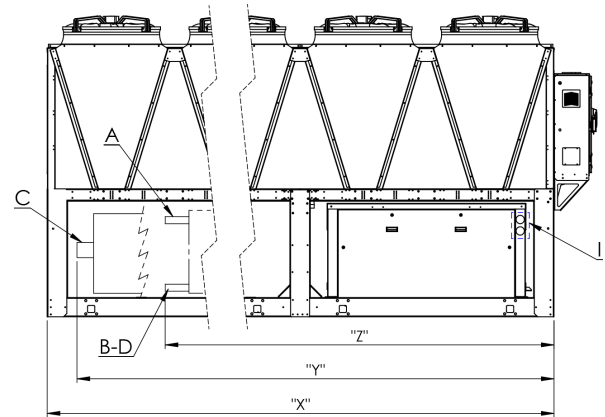

Back view

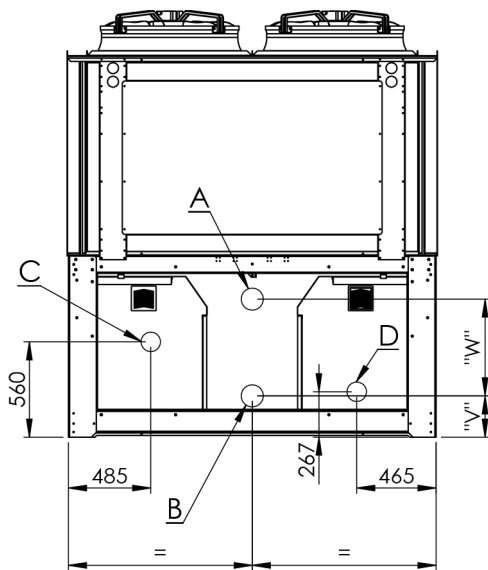

Top view

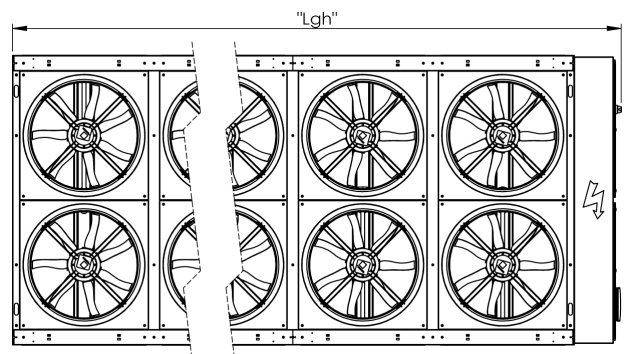

X	Footprint
Y	Tank outlet connection
Z	Standard hydraulic connection
Lgh	Total length
A	Standard inlet
B	Outlet
C	Outlet with tank
D	Inlet with pump/s
G	Electrical power supply
I	Gauge kit
L	Main Switch
M	Display

8 - Technical Data (continued)

Dimensions SYSCROLL AIR EVO 400-670 (continued)

Size	Dimension						Fan n	Hydro connection
	X	Y	Z	V	W	Lgh		A - B - C - D
400 CO	4230	4160	3900	240	568	4580	8	4"
400 HP	5270	5210	4430	240	568	5620	9	4"
400 CO S/HT	5270	5210	4430	240	568	5620	10	4"
400 HP S	6330	5430	4430	240	568	6680	11	4"
450 CO	5270	5210	4430	240	568	5620	10	4"
450 HP	5270	5210	4430	240	568	5620	10	4"
450 CO S/HT	6330	6300	4430	240	568	6680	12	4"
450 HP S	6330	6300	4430	240	568	6680	12	4"
490 CO	6330	5430	4430	240	568	6680	11	4"
490 HP	6330	5430	4430	240	568	6680	11	4"
490 CO S/HT	7390	7300	4930	240	568	7740	13	4"
490 HP S	7390	7300	4930	240	568	7740	13	4"
530 CO	6330	6300	4430	240	568	6680	12	4"
530 HP	6330	6300	4430	240	568	6680	12	4"
530 CO S/HT	7390	7300	4930	240	568	7740	14	4"
530 HP S	7390	7300	4930	240	568	7740	14	4"
600 CO	7390	7300	4930	260	615	7740	13	4"
600 CO S/HT	8450	7300	4950	260	615	8800	15	4"
580 HP	7390	7300	4930	240	568	7740	14	4"
580 HP S	8450	7300	4950	240	568	8800	16	4"
620 HP	8450	7300	4950	260	615	8800	15	5"
620 HP S	9500	7300	5970	260	615	9850	17	5"
670 CO	7390	7300	4930	260	615	7740	14	5"
670 CO S/HT	8450	7300	4950	260	615	8800	16	5"
670 HP	8450	7300	4950	260	615	8800	16	5"
670 HP S	9500	7300	5970	260	615	9850	18	5"

8 - Technical Data (continued)

Lift and AVM positions SYSCROLL AIR EVO 400-670

**Side view
4 lift position**

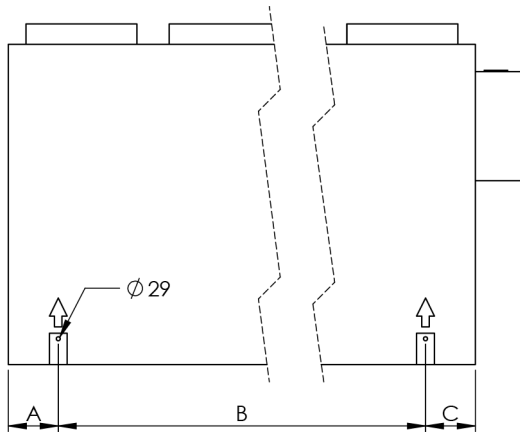

**Side view
8 lift position**

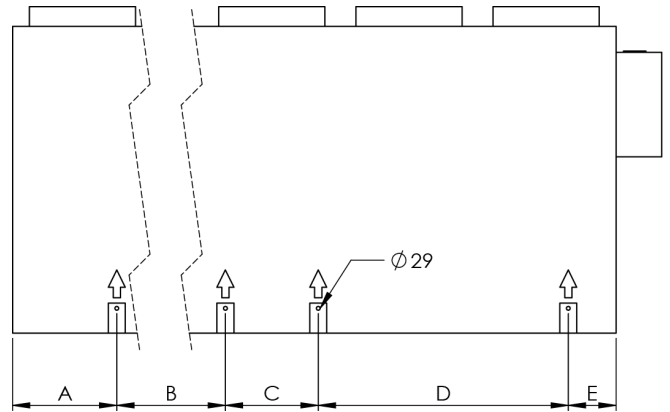

**Top view
4 AVM position**

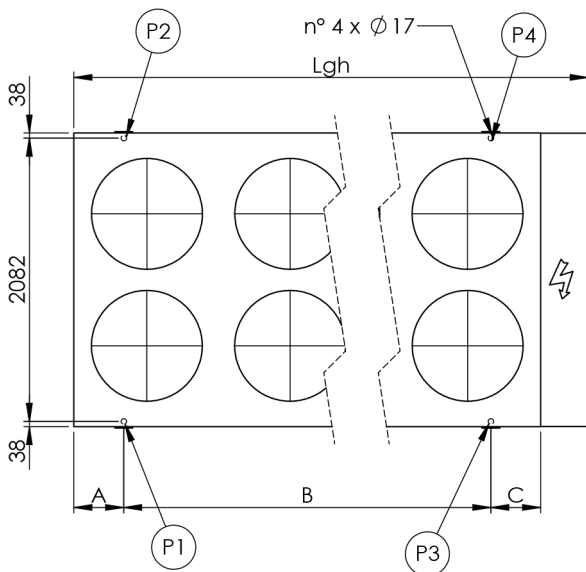

**Top view
8 AVM position**

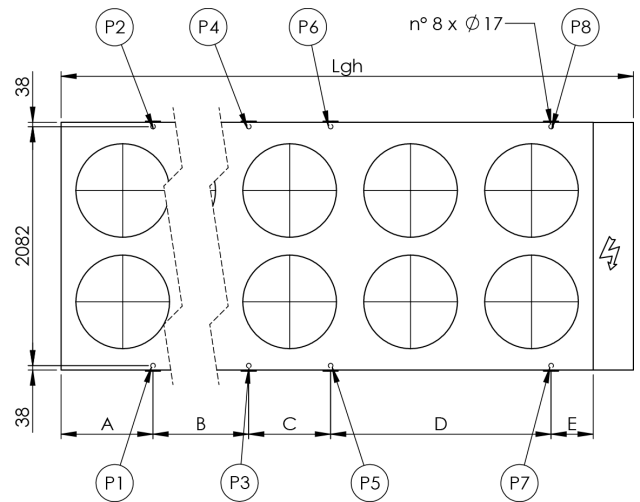

8 - Technical Data (continued)

Lift and AVM positions SYSCROLL AIR EVO 400-670 (continued)

Size	Dimension						Fan n
	A	B	C	D	E	Lgh	
400 CO	366	3496	366	/	/	4580	8
400 HP	366	4548	366	/	/	5620	9
400 CO S/HT	366	4548	366	/	/	5620	10
400 HP S	799	2537	712	1918	366	6680	11
450 CO	366	4548	366	/	/	5620	10
450 HP	366	4548	366	/	/	5620	10
450 CO S/HT	799	2537	712	1918	366	6680	12
450 HP S	799	2537	712	1918	366	6680	12
490 CO	799	2537	712	1918	366	6680	11
490 HP	799	2537	712	1918	366	6680	11
490 CO S/HT	366	2630	1392	1918	366	7740	13
490 HP S	366	2630	1392	1918	366	7740	13
530 CO	799	2537	712	1918	366	6680	12
530 HP	799	2537	712	1918	366	6680	12
530 CO S/HT	366	2630	1392	1918	366	7740	14
530 HP S	366	2630	1392	1918	366	7740	14
600 CO	366	2630	1392	1918	366	7740	13
600 CO S/HT	799	2537	2104	1918	366	8800	15
580 HP	366	2630	1392	1918	366	7740	14
580 HP S	799	2537	2104	1918	366	8800	16
620 HP	799	2537	2104	1918	366	8800	15
620 HP S	366	2630	3496	1918	366	9850	17
670 CO	366	2630	1392	1918	366	7740	14
670 CO S/HT	799	2537	2104	2630	366	8800	16
670 HP	799	2537	2104	2630	366	8800	16
670 HP S	366	2630	3496	2630	366	9850	18

8 - Technical Data (continued)

8.6 Dimensions SYSCROLL AIR EVO 750-900

Front view

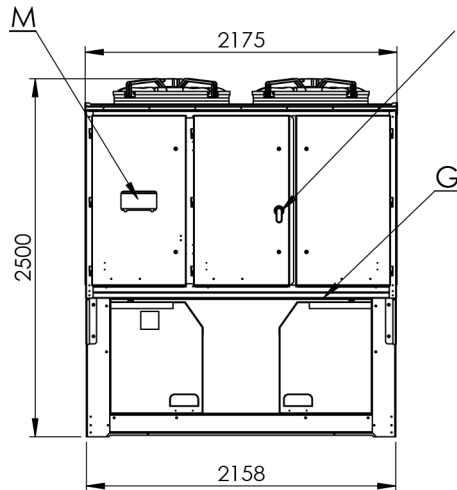

Side view

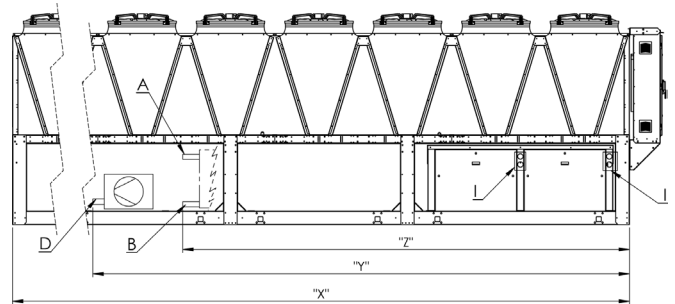

Back view

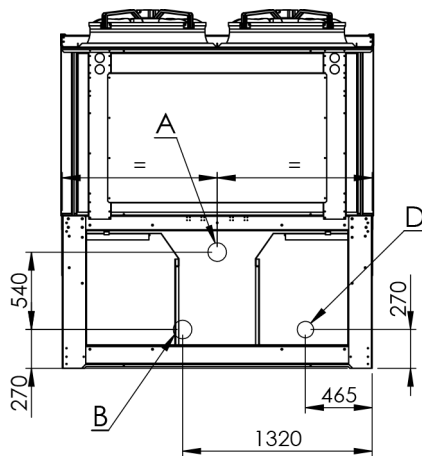

Top view

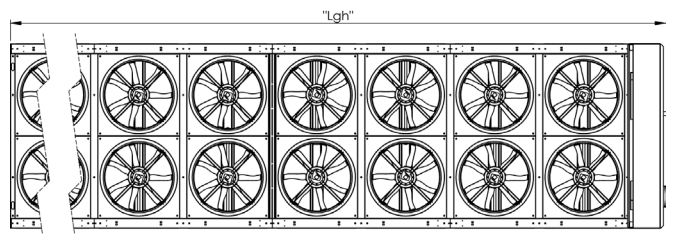

X	Footprint
Y	Tank outlet connection
Z	Standard hydraulic connection
Lgh	Total length
A	Standard inlet
B	Standard outlet
C	Outlet with tank
D	Inlet with pump/s
G	Electrical power supply
I	Gauge kit
L	Main Switch
M	Display

8 - Technical Data (continued)

Dimensions SYSCROLL AIR EVO 750-900 (continued)

Size	Dimension				Fan n	Hydro connection
	X	Y	Z	Lgh		A - B - D
750 CO	8440	8420	7300	8900	16	6"
750 HP	9490	8420	7300	9950	17	6"
750 CO S/HT	10540	8420	7300	11000	20	6"
750 HP S/HT	11590	8420	7300	12050	21	6"
800 CO	8440	8420	7300	8900	16	6"
800 HP	9490	8420	7300	9950	18	6"
800 CO S/HT	10540	8420	7300	11000	20	6"
800 HP S/HT	10540	8420	7300	12050	22	6"
850 CO	11590	8420	7300	9950	18	6"
850 HP	10540	8420	7300	11000	19	6"
850 CO S/HT	11590	8420	7300	12050	22	6"
900 CO	10540	8420	7300	11000	20	6"
900 HP	10540	8420	10540	11000	20	6"

8 - Technical Data (continued)

Lift and AVM positions SYSCROLL AIR EVO 750-900

Side view

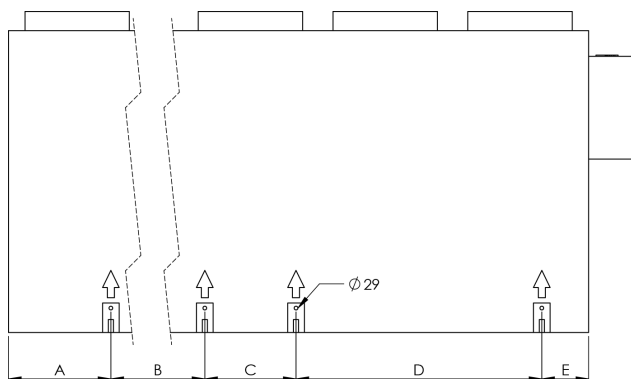

Top view

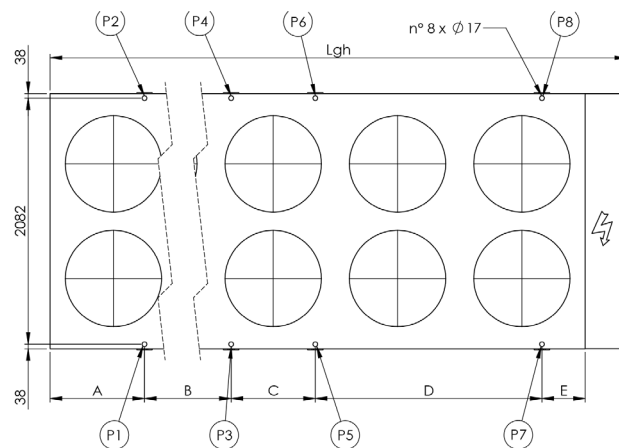

Size	Dimension						Fan n
	A	B	C	D	E	Lgh	
750 CO	799	2537	2104	2630	366	8900	16
750 HP	366	2630	3496	2630	366	9950	17
750 CO S/HT	799	4641	712	4022	366	11000	20
750 HP S/HT	366	4022	2816	4022	366	12050	21
800 CO	799	2537	2104	2630	366	8900	16
800 HP	366	2630	3496	2630	366	9950	18
800 CO S/HT	799	4641	712	4022	366	11000	20
800 HP S/HT	366	4022	2816	4022	366	12050	22
850 CO	366	2630	3496	2630	366	9950	18
850 HP	799	4641	712	4022	366	11000	19
850 CO S/HT	366	4022	2816	4022	366	12050	22
900 CO	799	4641	712	4022	366	11000	20
900 HP	799	4641	712	4022	366	11000	20

8 - Technical Data (continued)

8.7 Space requirements

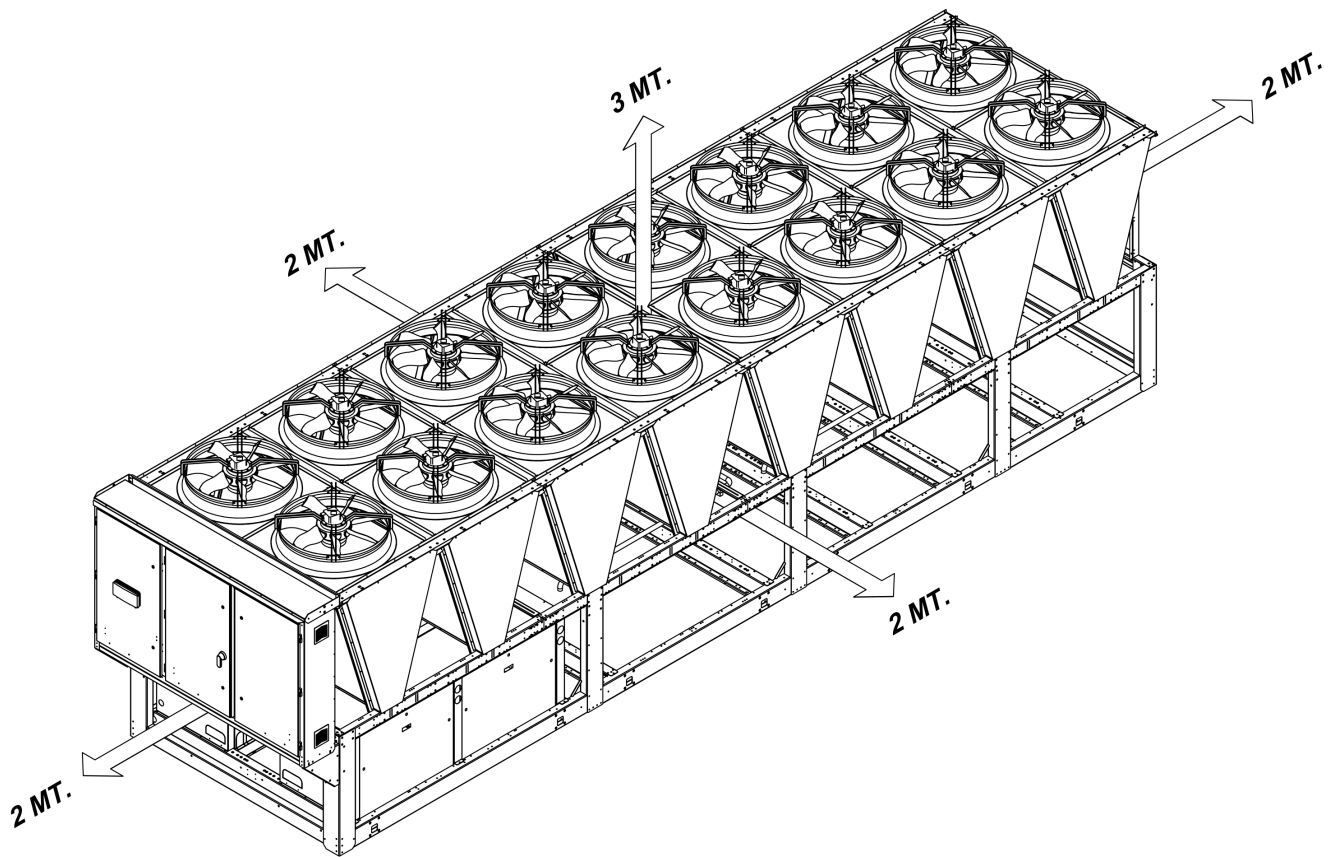

9 - Maintenance

Carefully read the “Safety” section of this manual before carrying out any maintenance operations.

	<p>Do not discharge the refrigerant into the atmosphere while the refrigeration circuits are being drained. Use appropriate recovery equipment.</p> <p>When the recovered refrigerant cannot be re-used, return it to the manufacturer.</p>
-----------------------------------------------------------------------------------	-----------------------------------------------------------------------------------------------------------------------------------------------------------------------------------------------------------------------------------------------------------

	<p>Do not throw away the waste oil of the compressor, because it contains refrigerant in solution.</p> <p>The waste oil must be returned to the manufacturer.</p>
-----------------------------------------------------------------------------------	---------------------------------------------------------------------------------------------------------------------------------------------------------------------------------

Unless otherwise specified, the operations described below may be carried out only by a trained maintenance operator.

9.1 General requirements

Units have been designed for continuous operation, providing that they are subjected to regular maintenance, within the limits specified in this manual. Each unit must be serviced according to the programme by the User/Customer, and must be inspected at regular intervals by the personnel of one authorised Service Centers.

It is the responsibility of the User to meet these maintenance requirements and/or to enter into an agreement with one of authorised Service Centers, so as to properly safeguard the operation of the appliance.

During the warranty period, in case of damage or failures caused by improper maintenance, manufacturer will not refund the costs incurred to repair the appliance in its original state.

The provisions of this section apply only to standard units; according to the order requirements, other documentation may be added, concerning any modifications or supplementary accessories.

9.2 Planned maintenance

Maintenance inspections must be carried out according to the program below, by a qualified person.

As a general rule, units cannot be repaired directly by the user, who shall not try to service or repair any failures or anomalies identified during daily inspections. If you are in doubt, please contact authorised Service Centre.

Operations	Daily	Weekly	Monthly	Beginning of season	End of season
Check the temperature of the leaving fluid	●				
Check the pressure drops in the heat exchanger		●			
Check for electric absorption		●			
Check suction pressure and temperature		●			
Check delivery pressure and temperature		●			
Check the oil level in the compressor		●			
Check that there are no gas bubbles in the liquid line		●			
Check that the fins of the external coil are clean (if any)			●		
Check the operation of the oil heaters			●		
Check the remote control switches			●		
Check the operation of the LP pressure switch				●	
Check the operation of the HP pressure switch				●	
Check the insulation of the heat exchanger				●	
Check that terminals are tightened				●	
Check that the terminals' screws are tightened				●	
Clean the exterior of the unit with water and soap				●	
Check the density of the antifreeze (if any)				●	●
Check the operation of the flow switches				●	
Check the operation of the solenoid valve				●	●

9 - Maintenance (continued)

9.3 Refrigerant charge

Do not inject refrigerant liquid into the LP side of the circuit. Be very careful, and charge the circuit properly. If the charge is insufficient, the efficiency of the unit will be lower than expected. (In the worst of cases the LP transducer may stop the unit.)

In the presence of an excess charge, the condensing pressure will rise (in the worst of cases, the HP pressure switch may be activated, resulting in the stop of the equipment), and the consumption will increase as well.

It is strictly forbidden to use the compressor as a vacuum pump to drain the plant.

Fill the refrigeration circuit after it has been drained for maintenance purposes (leaks, replacement of the compressor etc.). The amount of the charge is indicated on the plate affixed to the unit.

Before refilling, it is important to drain and de-hydrate the circuit, thus obtaining a minimum abs. pressure value of 50 Pa.

Inject the refrigerant fluid before removing the vacuum, then fill the circuit up to 90% of the total gas requirement (in liquid form). The appliance must be filled through the filling valve on the liquid line, on the outlet side of the condenser.

It is recommended to connect the refrigerant cylinder to the filling valve on the liquid line, and to arrange it in such a way as to inject only liquid refrigerant.

9.4 Compressor

Compressors are delivered with the necessary charge of lubricating oil. During normal operation, this charge is sufficient for the whole life of the unit, providing that the efficiency of the refrigeration circuit is satisfactory and if it has not been overhauled.

If the compressor needs to be replaced (following a mechanical failure or if burnt), contact one of authorised Service Centers.

Compressors use POE/PVE oil. During maintenance operations on the compressor, or if you have to open the refrigerant circuit in any point, remember that this type of oil is highly hygroscopic, and accordingly it is important that it is not left exposed to the weather for prolonged periods, as this would require the replacement of the oil.

9.5 Condenser

The condenser's coils consist of copper pipes and aluminium fins. In the presence of leaks caused by any damage or shock, the coils shall be repaired or replaced by one of authorised Service Centers. To ensure the effective and correct operation of the condenser coils, it is important to keep the condenser's surface perfectly clean, and to check that there is no foreign matter, such as leaves, wires, insects, waste etc. If the coil becomes dirty, there is an increase in the absorption of electric energy. Furthermore, the maximum pressure alarm may be activated and may halt the unit.

Be careful not to damage the aluminium fins during cleaning.

The condenser must be cleaned with a LP compressed air jet, parallel to the aluminium fins, in the direction opposite to the air circulation.

To clean the coil you can use also a vacuum cleaner, or a jet of water and soap.

9.6 Fans

The fans of the condenser, of axial type, are complete with impeller with aerodynamic profile blades and a cylindrical nozzle. The motor's bearings are lubricated forever.

9.7 Dehydrating filter

The refrigeration circuits are provided with dehydrating filters.

The filter clogging is marked by the presence of air bubbles in the sight glass, or by the difference between the temperatures measured downstream from and upstream of the drying filter. If, once the cartridge has been cleaned, there are still some air bubbles, the appliance has lost a part of the refrigerant charge in one or more points, that must be identified and serviced.

9.8 Sight glass

The sight glass is used for inspecting the refrigerant flow and the humidity % of the refrigerant. The presence of bubbles indicates that the dehydrating filter is clogged or the charge insufficient.

A colour indicator is positioned inside the sight glass. If you compare the colour of the indicator to the scale on the ring of the sight glass, you can calculate the percentage of humidity of the refrigerant. If it is excessive, replace the filter's cartridge, operate the appliance for 1 day and then check the humidity % again. When the humidity % is within the pre-determined range, no other operations are required. If the humidity % is still too high, replace the dehydrating filter again, start the unit and operate it for another day.

9 - Maintenance (continued)

9.9 Electronic Expansion Valve

The circuit of the unit is equipped with electronic expansion valve, with external equalizer. The valve is shop-calibrated for an overheating of 5°C.

Procedure to check for overheating:

- Measure the suction pressure with the pressure gauges on the board of the unit or using a pressure gauge connected to the service valve on the suction side.

- From the pressure gauge's temperature scale, measure the saturated suction temperature (T_{sa}) which corresponds to the pressure value.

- Using a contact pressure gauge affixed to the outlet fitting of the gas of the evaporator, measure the actual temperature (T_{se}).

Overheating calculation (S):

$$S = T_{se} - T_{sa}$$

Overheating is regulated through the electronic expansion valve.

If the expansion valve cannot be regulated, it is probably broken, and shall be replaced. The replacement must be carried out by a Service Centre.

9.10 Evaporator

Check at regular intervals that the water side of the heat exchanger is perfectly clean. To do this, measure the pressure drop, water side (see Section 8) or measure the temperature of the liquid leaving and entering the heat exchanger, and compare it to the evaporation temperature.

To obtain an effective heat exchange, the difference between the temperature of the leaving water and the saturated evaporating temperature must be in the 2 - 4°C range. A greater difference would indicate a low efficiency of the heat exchanger (i.e. the heat exchanger is dirty).

In this case, the heat exchanger must be subjected to chemical cleaning, an operation that shall be carried out by authorised engineers.

For other maintenance operations (extraordinary overhauling, replacement of the heat exchanger etc.), contact an authorised Service Centre.

10 - Troubleshooting

The table below lists the anomalies of operation of the unit, the relevant causes and the corrective measures. For anomalies of any other type or not listed, contact one of authorised Service Centre for technical assistance.

Anomaly	Cause	Operation
The unit continues to work, but without cooling	Insufficient charge of refrigerant.	Refill.
	The dehydrating filter is clogged.	Replace.
Ice on the suction line	Wrong calibration of overheating.	Increase overheating.
		Check the charge.
Excessive noise	Vibration of lines.	Check the clamping brackets, if any.
	Whistler emitted by the thermostatic expansion valve.	Refill.
		Check the dehydrating filter.
	Noisy compressor.	Seized bearings; replace the compressor.
Check that the compressor's locknuts are tightened.		
Low oil level in the compressor	One or more gas or oil leaks in the circuit.	Identify and remove leaks.
	Mechanical failure of the compressor.	Request the intervention of a Service Centre.
	Anomaly of the oil heater of the compressor's base.	Check the electric circuit and the resistor of the heater of the motor base, and replace defective components.
One or both compressors are not working	Breaking of the electric circuit.	Check the electric circuit and detect any ground dispersions and short circuits. Check fuses.
	Intervention of the HP pressure switch.	Reset the pressure switch and the control panel and restart the appliance. Identify and remove the cause that enabled the pressure switch.
	The fuse of the control circuit is broken.	Check for ground dispersions and short circuits. Replace fuses.
	Loosened terminals.	Check and tighten.
	Halt caused by thermal overload of the electric circuit.	Check the operation of check and safety devices. Identify and remove the cause.
	Wrong wiring.	Check wiring of check and safety devices.
	The line voltage is too low.	Check voltage. If problems regard the system, solve them. If they are caused by the distribution network, inform the Energy Distributor.
	Short-circuit of the compressor's motor.	Check the continuity of the winding.
Seized compressor.	Replace the compressor.	
Activation of the LP alarm, stop of the unit	Gas leak.	Identify and remove the leak.
	Insufficient charge.	Refill.
	Failure of the pressure switch.	Replace the pressure switch.
Activation of the HP alarm, stop of the unit	Failure of the pressure switch.	Check the operation of the pressure switch, replace it if defective.
	The delivery valve is partially closed.	Open the valve and replace it, if faulty.
	Substances with condensable gases in the circuit.	Drain the circuit.
	The fan of the condenser is stopped.	Check cables and motor. If defective, repair or replace.
The liquid line is too hot	Insufficient charge.	Identify and remove the cause of the loss of charge and refill.
Frosting of the liquid line	The valve of the liquid line is partially closed.	Check that valves are open.
	The liquid filter is clogged.	Replace the cartridge or the filter.

11 - Spare Parts

11.1 Spare part list

The table below shows the list of spare parts recommended during the first two years of operation.

Component	Number
Fan	1
Flow switch	1
High pressure transducer	1
Low pressure transducer	1
Expansion valve	1
Gas filter	1
4 way valve	1
Electronic main board	1
Auxiliary circuit transformer	1
Compressor contactor	2
Pump contactor	1
Water sensor	4
Air sensor	1
Auxiliary contact	4
Driver EEV	1
Fuses	4

11.2 Oil for compressors

The compressors are lubricated with POE / PVE oil.

11.3 Wiring diagrams

The wiring diagrams are installed inside the doors of the electrical panels of the unit. Any request for wiring diagrams shall be forwarded to manufacturer's Service Centre.

12 - Dismantling, Demolition and Scrapping



During the draining of the refrigeration circuits, do not let the refrigerant overflow in the surrounding atmosphere.

The circuit must be drained using suitable recovery equipment.



Do not disperse the waste oil of the compressors in the environment, since it contains some dissolved refrigerant.

For the disposal, contact the competent authority for information.

Unless otherwise specified, the maintenance operations listed below may be carried out by any trained maintenance operator.

12.1 Generalities

Open each line that supplies the unit, including the ones of control circuits. Make sure that all disconnecting switches are secured in the off position. The power cables can be disconnected and disassembled. Refer to Chapter 4 for the position of connection points.

Remove all the refrigerant from the refrigeration circuits of the unit and store it in suitable containers, using a recovery unit. If its characteristics have remained the same, the refrigerant can be used again. Contact the competent authority to obtain information about disposal. In **NO** event shall the refrigerant be discharged into the atmosphere. The oil in each refrigeration circuit must be drained and collected into a suitable container; then it shall be disposed of in conformity with local regulations that apply to the disposal of waste lubricants. Any oil spillage must be recovered and disposed of in like manner.

Isolate the unit's heat exchangers from the external hydraulic circuits and drain the heat exchange sections of the plant.



If no shutoff valves have been provided, it may be necessary to drain the whole plant.

If a glycoled solution or a similar fluid has been used in the hydraulic circuits, or if chemical additives have been added to the circulating water, the circulating fluid MUST be drained in a proper way.

For NO reason shall a circuit containing glycoled water or a similar solution be discharged directly into the drains or surface waters.

After draining operations, the piping of the hydraulic networks can be disconnected and disassembled.

Once they have been disconnected as specified, the packaged units can be disassembled in a single piece. First of all, disassemble the anchoring screws and then lift the unit from the position of installation, and hook it to the lifting points provided, using suitable lifting equipment.

To this end, refer to Chapter 4 for the installation of these appliances, to Chapter 8 for their weights and Chapter 3 for handling.

The units that, once disconnected, cannot be removed in a single piece, must be dismantled on site; in this case, be very careful with the weight and handling of every single component.

It is always advisable to dismantle the units following the installation steps, but in reverse.



Some residues of oil, glycoled water or similar solutions may remain in certain parts of the unit. These residues must be recovered and disposed of according to the procedures specified above.

It is very important to ensure that, while a component of the unit is being removed, all the others are properly supported.



Use only lifting means of adequate capacity.

Once disassembled, the components of the unit can be disposed of in conformity with current regulations.

12.2 RAEE Directive (only UE)



- The RAEE Directive requires that the disposal and recycling of electrical and electronic equipment must be handled through a special collection, in appropriate centers, separate from that used for the disposal of mixed urban waste.
- The user has the obligation not to dispose of the equipment at the end of the useful life as municipal waste, but to send it to a special collection center.
- The units covered by the RAEE Directive are marked with the symbol shown above.
- The potential effects on the environment and human health are detailed in this manual.

Systemair srl
Via XXV Aprile, 29
20825 Barlassina (MB)
Italy

Tel. +39 0362 680 1
Fax +39 0362 680 693

www.systemair.com



As part of our ongoing product improvement programme, our products are subject to change without prior notice. Non contractual photos.

Dans un souci d'amélioration constante, nos produits peuvent être modifiés sans préavis. Photos non contractuelles.

In dem Bemühen um ständige Verbesserung können unsere Erzeugnisse ohne vorherige Ankündigung geändert werden. Fotos nicht vertraglich bindend.

A causa della politica di continua migliona posta in atto dal costruttore, questi prodotti sono soggetti a modifiche senza alcun obbligo di preavviso. Le foto pubblicate non danno luogo ad alcun vincolo contrattuale.

Con objeto de mejorar constantemente, nuestros productos pueden ser modificados sin previo aviso. Fotos no contractuales.

