

Elektra C

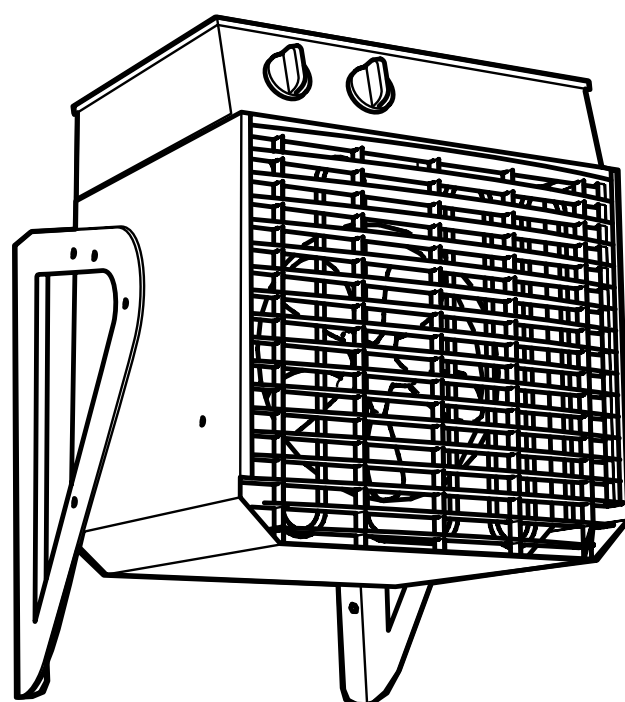

SE ... 9	EN ... 11	NO ... 13	FR ... 15
RU ... 17	DE ... 19	PL ... 22	FI ... 24
NL ... 26	ES ... 29	IT ... 32	

Elektra C

ELC331

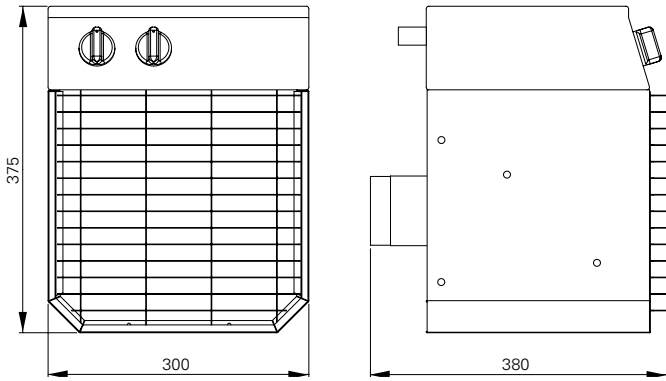

ELC623, ELC633, ELC923, ELC933, ELC1533

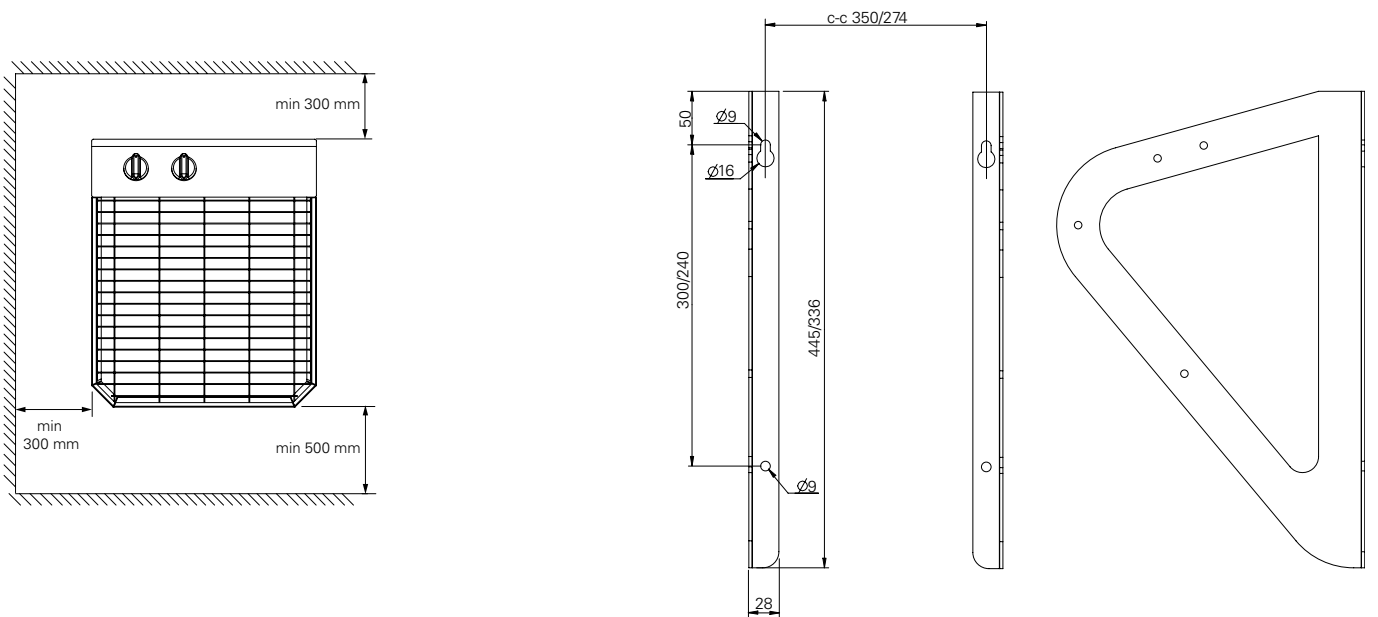
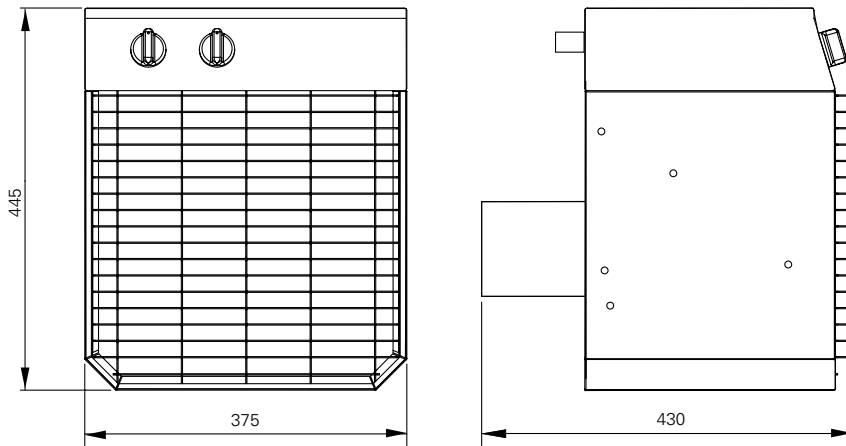

Fig. 1

Fig. 2

Elektra C

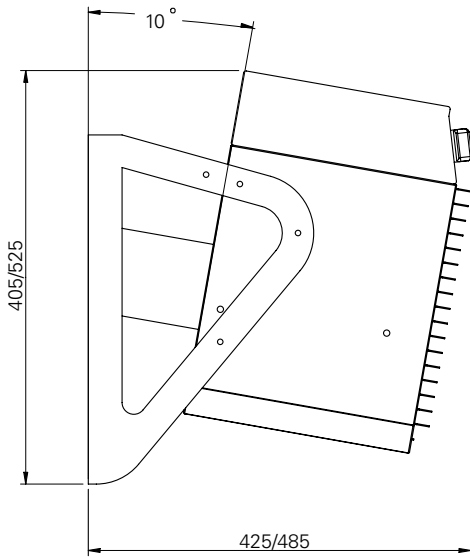

Fig. 3

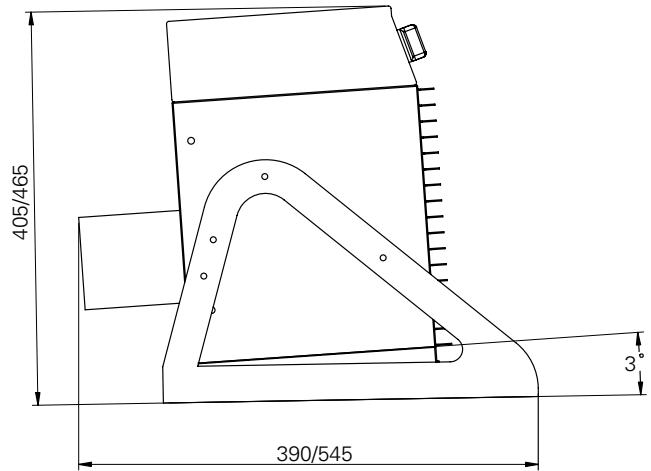

Fig. 4

Technical specifications

Type	Output [kW]	Output steps [kW]	Voltage [V]	Amperage [A]	Airflow [m ³ /h]	Sound level ^{*1} [dB(A)]	Δt ^{*2} [°C]	Weight [kg]
ELC331	3	0/1/2/3	230V~	9.1/13.5	400	48	21	13
ELC623	6	0/1/3/6	230V3~	7.8/15.4	1000	55	17	20
ELC633	6	0/1/3/6	400V3~	4.5/8.9	1000	55	17	20
ELC923	9	0/1/4.5/9	230V3~	11.6/22.9	1000	55	25	20
ELC933	9	0/1/4.5/9	400V3~	6.7/13.2	1000	55	25	20
ELC1533	15	0/1/7.5/15	400V3~	11.2/22	1300	62	32	20

1) Distance to fan: 5 metres.

2) Δt = Temperature rise of passing air at maximum heat output.

Elektra C

Elektra C 230V~
ELC331

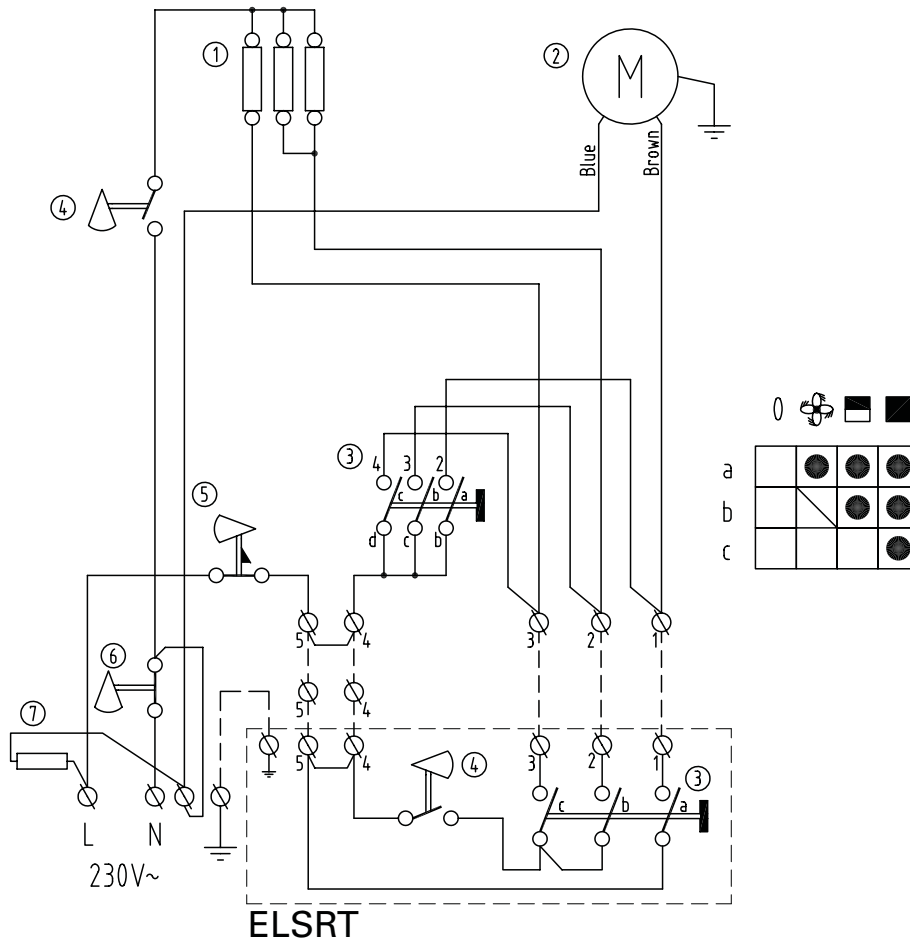

①	Element/Værmeelement/Element/Elementii/Element/Heizelement/ Verwarmingselement
②	Fläktmotor/Ventilator/Viftemotor/Puhallinmoottori/ Fan motor/ Gebläse motor/Moteur de ventilateur/Ventilatormotor
③	Brytare/Afbryder/Bryter/Katkaisin/Switch/Schalter/Interrupteur/ Schakelaar
④	Termostat/Termostat/Termostat/Termostaatti/Thermostat/Thermost/Thermostat/ Thermostaat
⑤	Överhettningsskydd/Overophedningsbeskytter/Overhettingsvern/Ylikuumenemissuoja/ Overheating cut-out/Überhitzungsschutz/Protection contre la surchauffe/ Oververhittingsthermostaat
⑥	Överhettningsskydd/Overophedningsbeskytter/Overhettingsvern/Ylikuumenemissuoja/ Overheating cut-out/Überhitzungsschutz/Protection contre la surchauffe/ Oververhittingsthermostaat
⑦	Effektmotstånd/Effektmodstand/Effektmotstand/Vastus/Power resistor/Heiz Element/ Résistance Chutrice/Vermogensweestand

Elektra C

Elektra C 400V3~
ELC633, ELC933

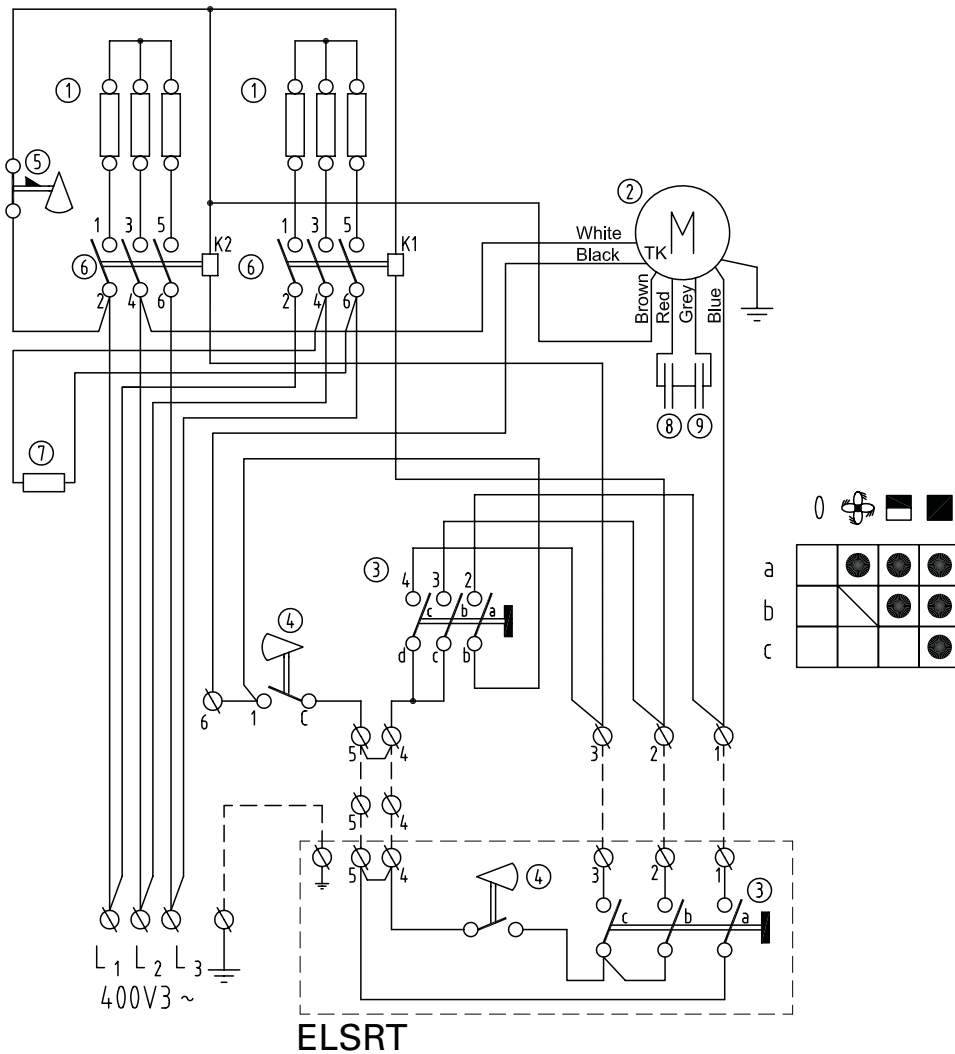

①	Element/Værmeelement/Element/Elementii/Element/Heizelement/ Verwarmingselement
②	Fläktmotor/Ventilator/Viftemotor/Puhallinmoottori/ Fan motor/ Gebläse motor/Moteur de ventilateur/Ventilatornotor
③	Brytare/Afbryder/Bryter/Katkaisin/Switch/Schalter/Interrupteur/ Schakelaar
④	Termostat/Termostat/Termostat/Termostaatti/Thermostat/Thermost/Thermostat/ Thermostaat
⑤	Överhettningsskydd/Overophedningsbeskytter/Overhettingsvern/Ylikuumenemissuoja/ Overheating cut-out/Überhitzungsschutz/Protection contre la surchauffe/ Oververhittingsthermostaat
⑥	Kontaktor/Kontaktor/Kontaktor/Kontaktori/Contactor/Schutz/Contacteur/Relais
⑦	Effektmotstånd/Effectmodstand/Effectmotstand/Vastus/Power resistor/Heiz Element/ Résistance Chutrice/Vermogensweestand
⑧	Kondensator/Kondensator/Kondensator/Kondensaattori/Capacitor/Kondensator/ Condensator 3µF
⑨	Kondensator/Kondensator/Kondensator/Kondensaattori/Capacitor/Kondensator/ Condensator 4µF

Elektra C

Elektra C 400V3~
ELC1533

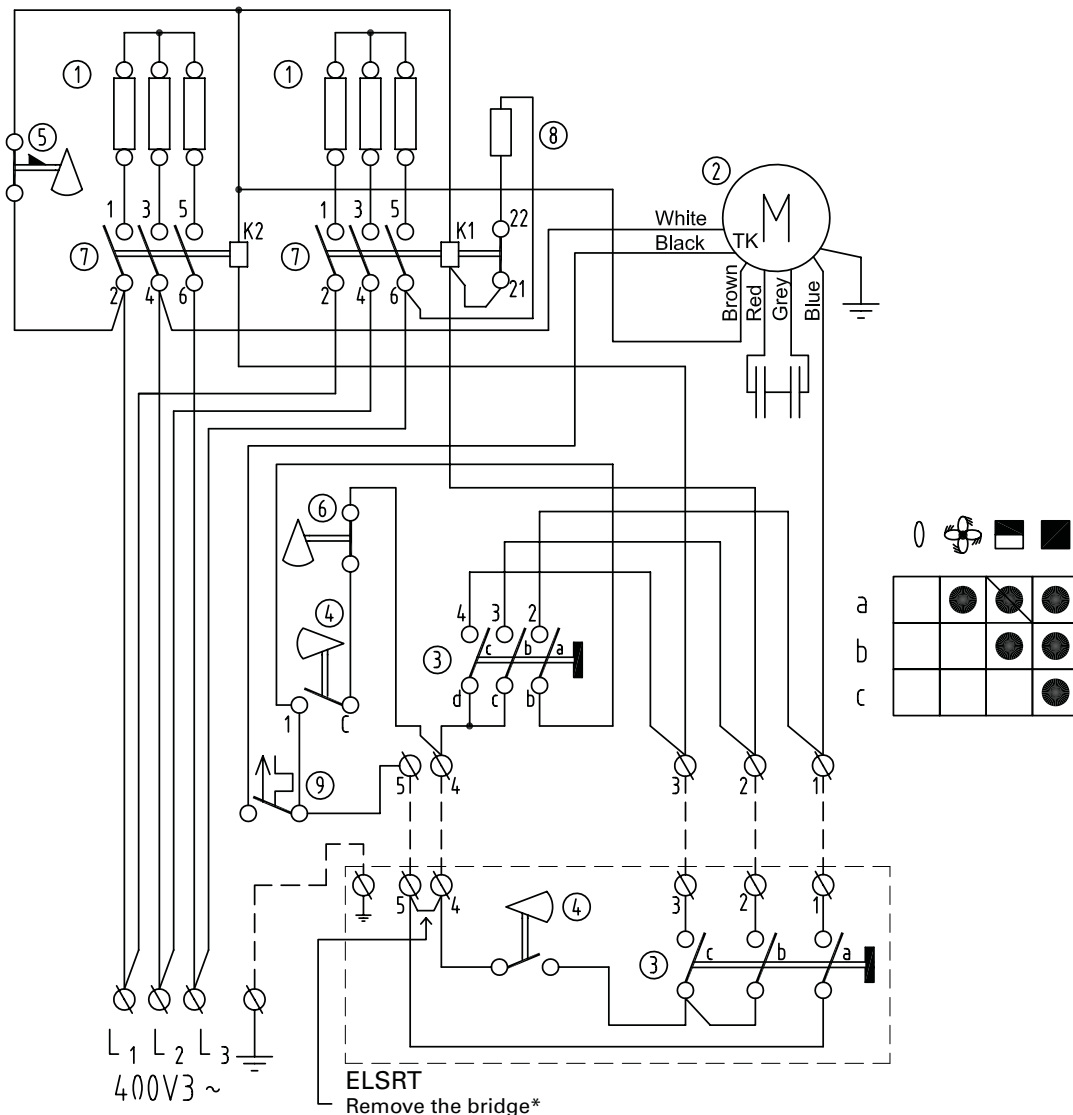

* Ta bort bygel. / Fjern klemmen. / Poista siltaus. / Die Überbrückung entfernen. / Retirer le shunt. / Retire el puente. / Verwijder de brug. / Удалите перемычку. / Usuń zworę.

①	Element/Værmeelement/Element/Elementii/Element/Heizelement/ Verwarmingselement
②	Fläktmotor/Ventilator/Viftemotor/Puhallinmoottori/ Fan motor/ Gebläse motor/Moteur de ventilateur/Ventilatormotor
③	Brytare/Afbryder/Bryter/Katkaisin/Switch/Schalter/Interrupteur/ Schakelaar
④	Termostat/Termostat/Termostat/Termostaatti/Thermostat/Thermost/Thermostat/ Thermostaat
⑤	Överhettningsskydd/Overophedningsbeskytter/Overhettingsvern/Ylikuunenemissuoja/ Overheating cut-out/Überhitzungsschutz/Protection contre la surchauffe/ Oververhittingsthermostaat
⑥	Överhettningsskydd/Overophedningsbeskytter/Overhettingsvern/Ylikuunenemissuoja/ Overheating cut-out/Überhitzungsschutz/Protection contre la surchauffe/ Oververhittingsthermostaat
⑦	Kontaktor/Kontaktor/Kontaktor/Kontaktori/Contactor/Schutz/Contacteur/Relais
⑧	Effektmotstånd/Effectmodstand/Effectmotstand/Vastus/Power resistor/Heiz Element/ Résistance Chutrice/Vermogensweestand
⑨	Dvärgbrytare/Automatsikring/Automatsikring/Sulakeautomattti/Miniature circuit breaker/ Leitungsschutzschalter/Coupe-circuit miniature/Miniatuuronderbreker

Elektra C

Elektra C 230V3~
ELC623, ELC923

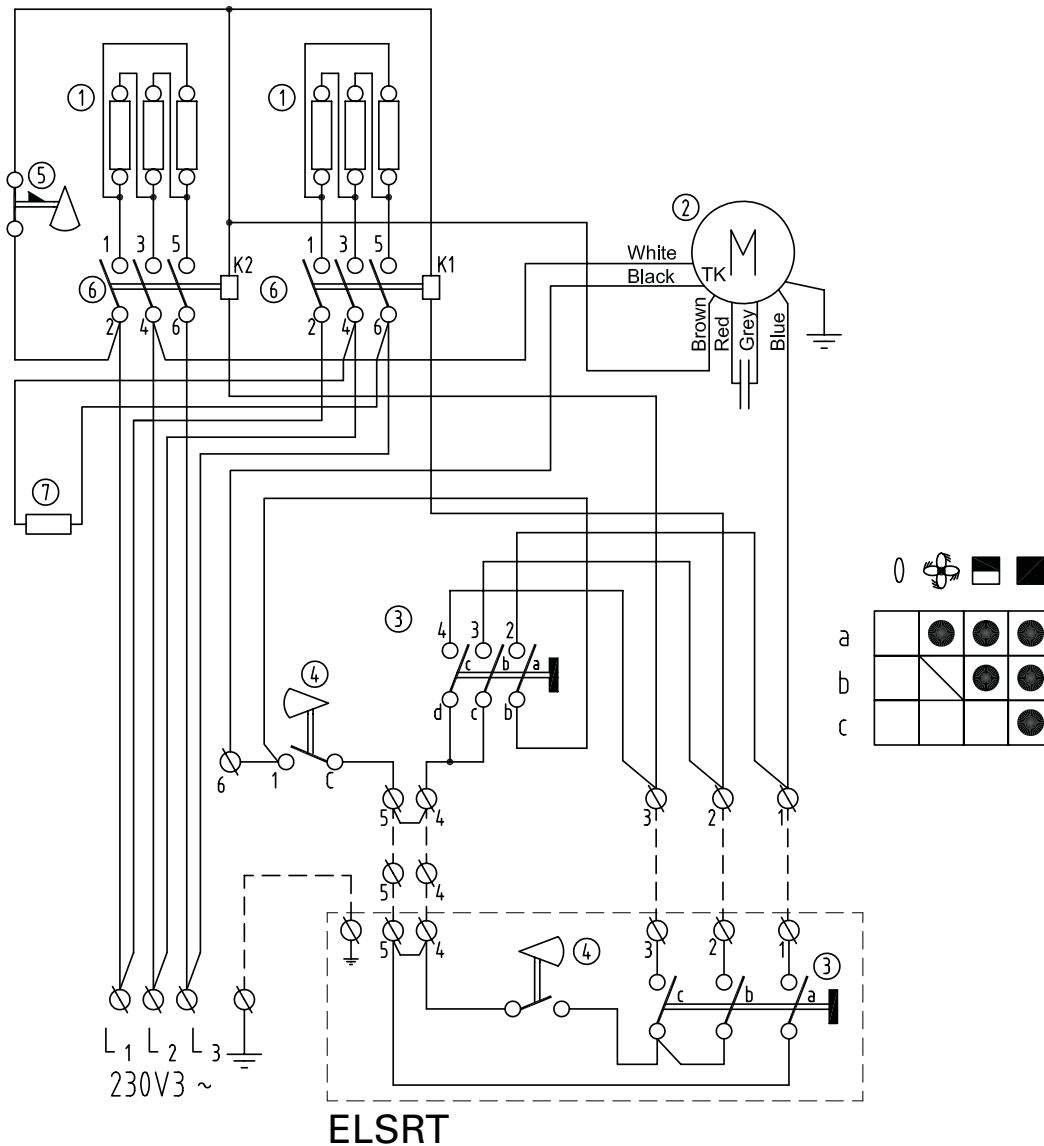

①	Element/Værmeelement/Element/Elementii/Element/Heizelement/ Verwarmingselement
②	Fläktmotor/Ventilator/Viftemotor/Puhallinmoottori/ Fan motor/ Gebläse motor/Moteur de ventilateur/Ventilatornotor
③	Brytare/Afbryder/Bryter/Katkaisin/Switch/Schalter/Interrupteur/ Schakelaar
④	Termostat/Termostat/Termostat/Termostaatti/Thermostat/Thermost/Thermostat/ Thermostaat
⑤	Överhettningsskydd/Overophedningsbeskytter/Overhettingsvern/Ylikuumenemissuoja/ Overheating cut-out/Überhitzungschutz/Protection contre la surchauffe/ Oververhittingsthermostaat
⑥	Kontaktor/Kontaktor/Kontaktor/Kontaktori/Contactor/Schutz/Contacteur/Relais
⑦	Effektmotstånd/Effectmodstand/Effectmotstand/Vastus/Power resistor/Heiz Element/ Résistance Chutrice/Vermogensweestand

Elektra C

ELSRT

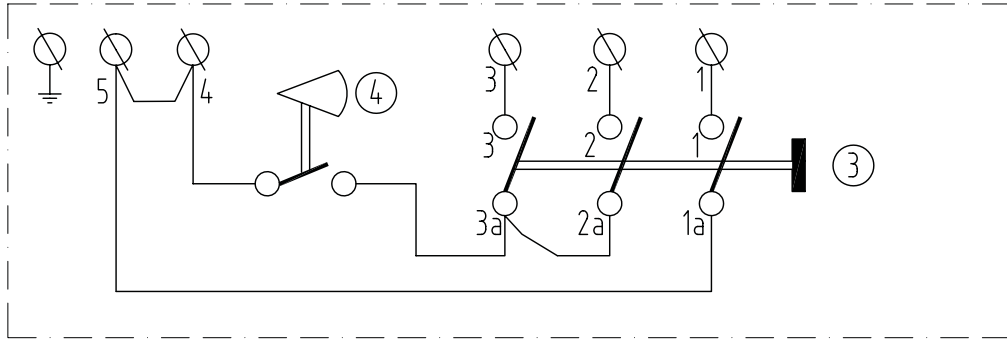
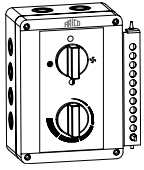

ELSRT

③ Switch

④ Thermostat

ELSRT4

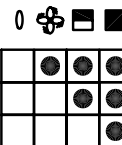
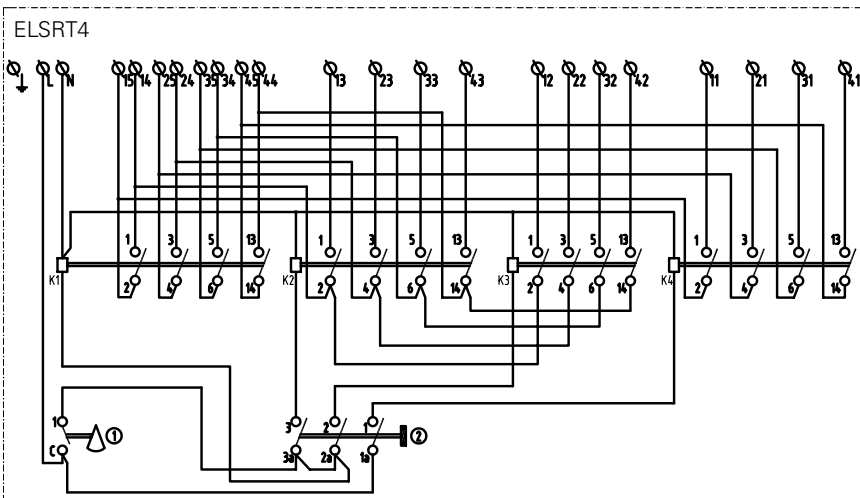
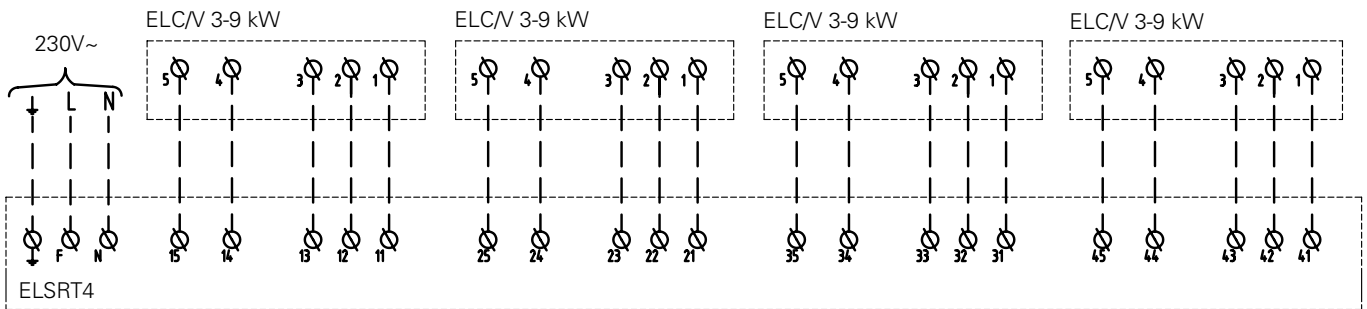
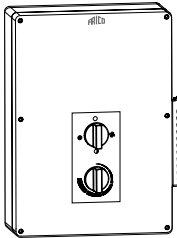

- ① Thermostat
- ② Switch

Mounting and assembly instruction

Application area

The fan heater is approved for damp and wet conditions and can be used in corrosive environments, like car washes and other tough conditions. For both fixed installation and portable use.

The fan heater should be installed for easy maintenance and inspection. For portable use, mount a suitable terminal with appropriate protection class. The fan heater is tested and approved according to the EMC- and SEMKO regulations and is CE compliant.





Protection class: IP65.

The casing is made of acid resistant stainless steel SS2348, heating rods in stainless steel SS2320, brackets and front grille in powder coated stainless steel.

Operation

The fan is running constantly unless the output selector is set in 0 position. The heat output is controlled by the built in thermostat (0 – 35°C) or with an external thermostat (KRT1900).

The on/off mode, and half or full heat output can be controlled with the output selector on the unit or with an external control panel (ELSRT/ELSRT4) mounted on the wall for easy access. External control box or thermostat are ordered separately.

	Off
	Only fan
	Fan + half output
	Fan + full output

Mounting

Elektra C can be mounted permanently on the wall or be used as a portable fan heater.

Wall mounting

The fan heater must not be placed immediately or directly below or in front of a wall socket. Remove the plastic feet on the brackets.

1. Drill four holes in the wall with a c-c distance according to fig. 2 on page 2. Fit the screws in the upper two holes.
2. Attach the brackets on to the fan heater according to fig. 3 on page 3 with three screws on each side.
3. Hang the heater by using the keyholes in the bracket and lock with the two lower screws.

Note! The minimum distances according to fig. 1 on page 2.

Portable use

Mount the enclosed brackets according fig. 4 on page 3.

Electrical installation

The electrical installation should be carried out by a qualified electrician in conformity with prevailing regulations. The appliance should be preceded by an omnipolar switch with at least 3 mm breaking gap.

Use the knock-outs on the back of the appliance for installation of the external devices. Cable-glands used must guarantee the protection class requirements.

Overheating

Note! Opening the heater cover should only be done by a qualified installer.

The heater is equipped with an overheat protection with manual reset. If it is released due to overheating, reset as follows:

- Disconnect the power supply with the omnipolar switch.
- Investigate the matter and repair the fault.
- Reset cut-out by opening the lid and pressing the red button until a click is heard.
- Put on the lid and make sure that the screws are tightened to ensure full protection. If the fault continues, please contact a qualified technician.

Care and maintenance

Elektra C should only be switched off using the output selector on the unit or the external control panel ELSRT/ELSRT4. A heating element is placed inside the junction box and prevents dampness even when the appliance is switched off. See wiring diagrams, component 7.

Note! Opening the heater cover should only be done by a qualified installer. Always disconnect the power supply before opening the cover or doing any maintenance work.

The appliance should be cleaned regularly both inside and outside, to prevent overheating and risk of fire but also to guarantee long life of the heater.

Note! To keep the protection class it is very important to tighten the screws properly when the lid is put back again after installation or maintenance. When the screw has reached the rubber gasket, continue another 2 1/2 turns.

Packaging

Packaging materials are chosen with consideration to environment and are therefore recyclable.

Handling of product at end of working life

This product may contain substances necessary for functionality of product but potentially dangerous for the environment. The product should not be disposed mixed with general household waste but delivered to a designated collection point for environmental recycling. Please contact local authority for further details of your nearest designated collection point.

Safety instructions

Incorrect installation and/or incorrect usage of the fan heater can be hazardous.

Warning!

- *Always disconnect the fan heater before opening the cover or doing any electrical work.*
- *Incorrect installation can lead to personal injury.*
- *Opening the heater cover etc should only be done by a qualified installer*
- *This fan heater must not be used next to a shower, bath or swimming pool.*
- *Place the fan heater away from flammable materials*
- *Ensure that the area around the intake and exhaust grille is kept free from material which could obstruct the air flow through the unit!*
- *The unit must not be covered fully or partially with clothes, or similar materials, as overheating can result in a fire risk!*
- *The fan heater is fitted with a cable that, in the event of damage, must be changed by a qualified installer.*
- *This appliance can be used by children aged from 8 years and above and persons with reduced physical, sensory or mental capabilities or lack of experience and knowledge if they have been given supervision or instruction concerning use of the appliance in a safe way and understand the hazards*

involved. Children shall not play with the appliance. Cleaning and user maintenance shall not be made by children without supervision.

- *Children of less than 3 years should be kept away unless continuously supervised.*
- *Children aged from 3 years and less than 8 years shall only switch on/off the appliance provided that it has been placed or installed in its intended normal operating position and they have been given supervision or instruction concerning use of the appliance in a safe way and understand the hazards involved.*
- *Children aged from 3 years and less than 8 years shall not plug in, regulate and clean the appliance or perform user maintenance.*

CAUTION — Some parts of this product can become very hot and cause burns. Particular attention has to be given where children and vulnerable people are present.

Important!

When using the heater as a portable, the brackets must be turned in order to use them as a floor stand (see fig 4 on page 3).

The guarantee is only valid if the units are used in the manner intended by the manufacturer and in accordance with the installation and maintenance instructions.

Accessories

For fixed installation the heater can be controlled by an external control panel with a built in thermostat 0 – +35°C. It is also possible to use only an external thermostat to control the heat output. The ELSRT can only control one unit. For parallel connection of up to 4 units the ELSRT4 can be used. When ELSRT is being used, the built-in thermostat must be set to max and the output selector on the unit to Off .

See table below.

Type	Description	HxWxD [mm]
ELSRT	Control panel and thermostat, controls one fan heater, IP65	175x150x100
ELSRT4	Control panel and thermostat (not ELC1533), controls 4 fan heaters, IP65	255x360x110



Main office

Frico AB
Industrivägen 41
SE-433 61 Sävedalen
Sweden

Tel: +46 31 336 86 00

mailbox@frico.se

www.frico.net

**For latest updated information and information
about your local contact: www.frico.se**