

Original instructions  
**Panther FC 20 - 30 kW**

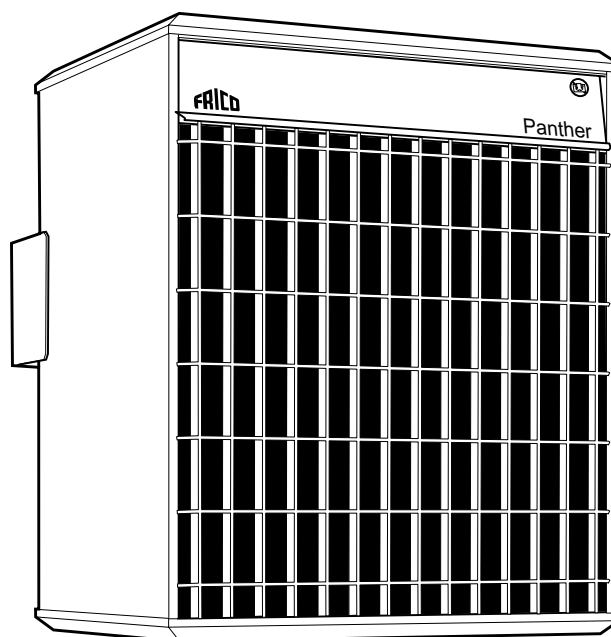

EN ... 11

FR ... 13

DE ... 16

SE ... 19

NO ... 22

DK ... 25

FI ... 28

NL ... 31

ES ... 34

IT ... 37

PL ... 40

RU ... 43

# Panther FC 20-30

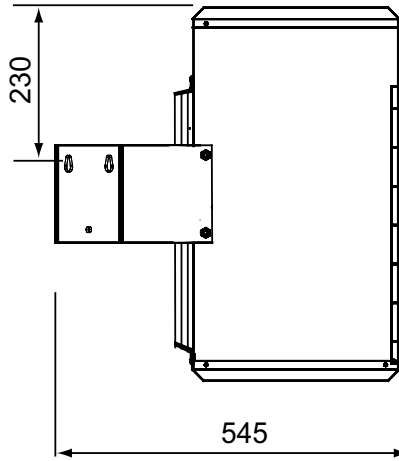
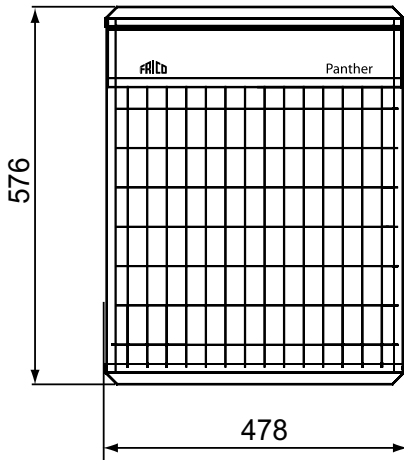

## Minimum mounting distance

Wall

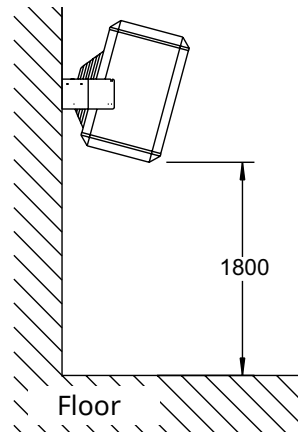
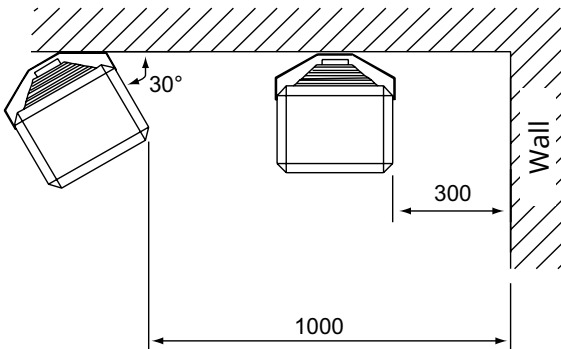

Ceiling

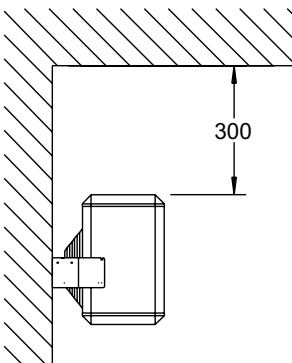

- FR: Distances minimales
- DE: Mindestabstand
- SE: Minimiavstånd
- NO: Minsteavstand
- DK: Minimumsafstande
- FI: Minimietäisyydet
- NL: Minimale afstand
- ES: Distancias mínimas
- IT: Distanze minime
- PL: Minimalne odległości
- RU: Минимальные расстояния при установке

1 Detach bracket from the unit

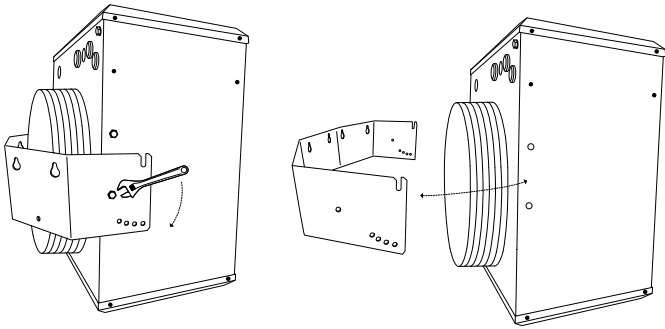

2 Mark and drill holes

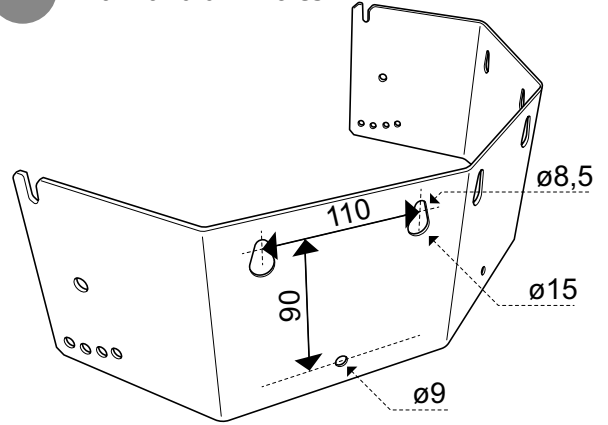

3 Mount the bracket on the wall

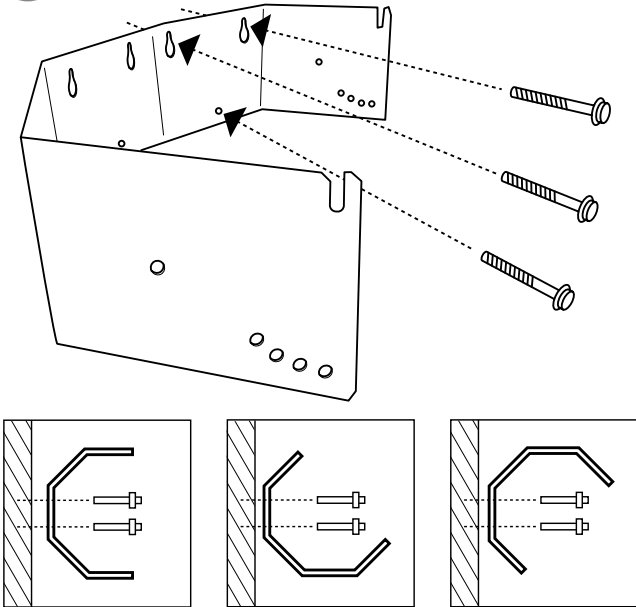

4 Hang the unit on the bracket

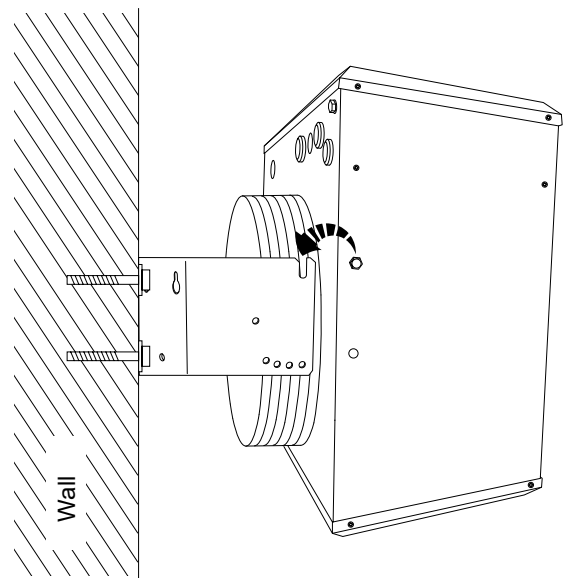

5 Adjust the angle and fix it with the lower screws

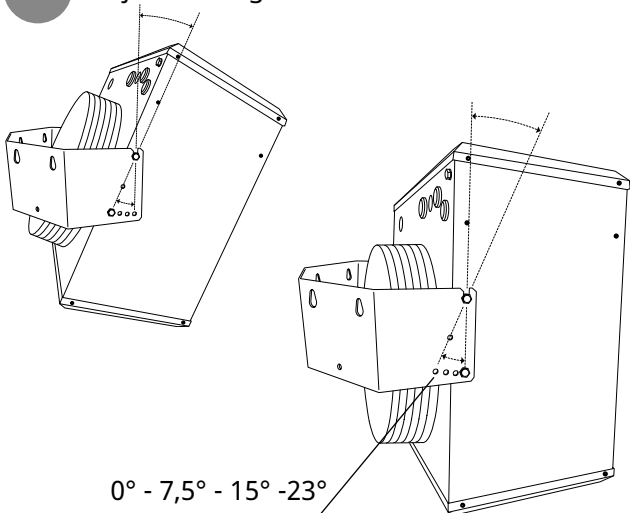

6 Tighten all screws.

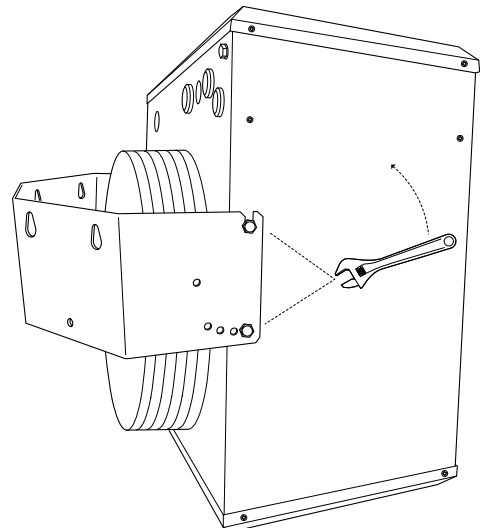

# Panther FC 20-30

## Connection

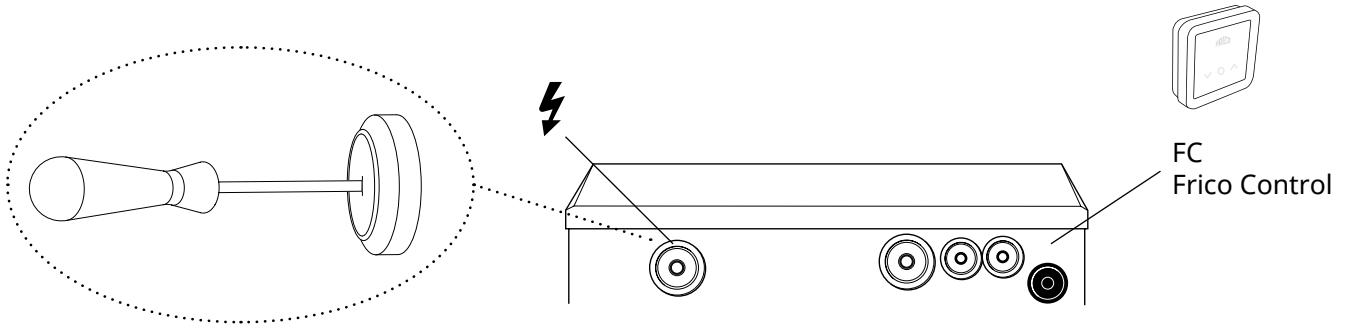

PNF20  
PNF2023

PNF30  
PNF3023

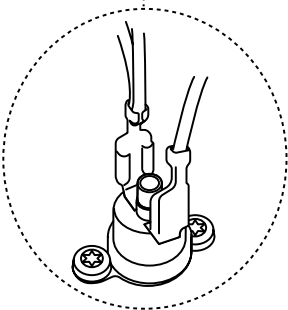
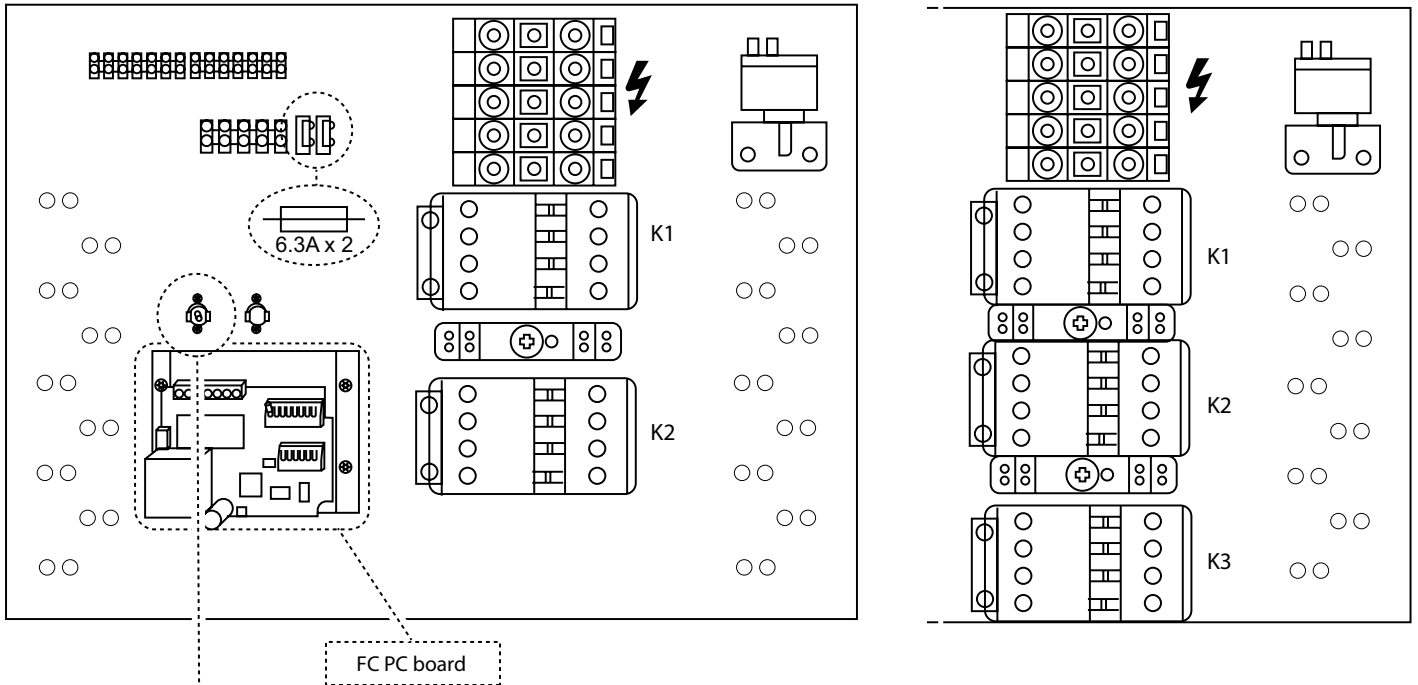

## Resetting the overheat protection

- FR: Réinitialisation de la protection anti-surchauffe
- DE: Zurücksetzen des Überhitzungsschutzes
- SE: Återställning överhettningsskydd
- NO: Tilbakestill overopphetingsvernet
- DK: Nulstilling af overophedningsbeskyttelsen
- FI: Ylikuumenemissuojan palauttaminen
- NL: Resetten van de oververhittingsbeveiliging
- ES: Reajustar la protección contra el sobrecalentamiento
- IT: Ripristino della protezione termica
- PL: Resetowanie zabezpieczenia przed przegrzaniem
- RU: Перезапуск защиты от перегрева

## Panther FC 20-30

Item number	Type	Voltage [V]	Minimal Cross section cable [mm <sup>2</sup> ]	Nominal Cross section for terminal block [mm <sup>2</sup> ]
334031	<b>PNF20</b>	400V3N~	10	35
334032	<b>PNF2023</b>	230V3~	16	35
334033	<b>PNF30</b>	400V3N~	16	35
334035	<b>PNF3023</b>	230V3~	25	70

FR: Section transversale minimale du câble. Section transversale nominale du bornier.

DE: Mindestquerschnitt Kabel. Nennquerschnitt Klemmleiste.

SE: Minsta kabelarea. Nominell area inkopplingsplint.

NO: Minste kabelareal. Nominelt areal rekkeklemme.

DK: Minimalt tværsnit af kabel. Nominelt tværsnit for rækkelemme.

FI: Kaapelin pienin poikkipinta-ala. Liitinriman nimellispoikkipinta-ala.

NL: Minimale doorsnede kabel. Nominale doorsnede klemmenstrook.

ES: Sección transversal mínima Cable. Sección transversal nominal Bloque de bornas.

IT: Cavo con sezione trasversale minima. Sezione nominale morsettiera.

PL: Minimalny przekrój przewodu. Nominalny przekrój listwy zaciskowej.

RU: Минимальное сечение силового кабеля. Макс. сечение кабеля для гнезда клеммника.

### Accessories

Item number	Type	HxWxD [mm]
10275	<b>PLR30</b>	415x445x60

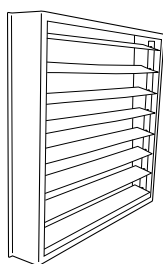

PLR30

## Control systems FC Frico control

The fan heater must be supplemented with a FC control system.

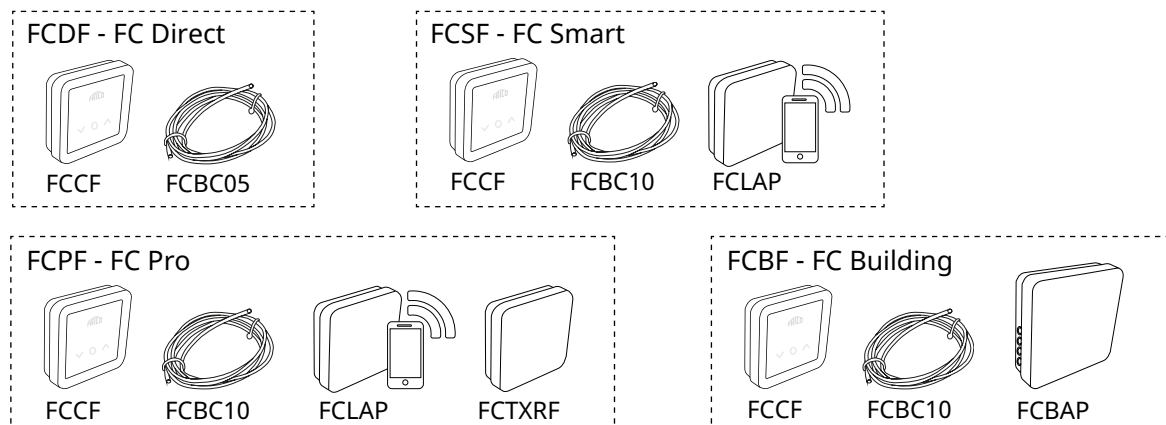

Item number	Type	Name	Dimensions
74688	<b>FCDF</b>	FC Direct	89x89x26 mm (FCCF)
74689	<b>FCSF</b>	FC Smart	89x89x26 mm (FCCF)
74690	<b>FCPF</b>	FC Pro	89x89x26 mm (FCCF)
74691	<b>FCBF</b>	FC Building	89x89x26 mm (FCCF)

## Accessories

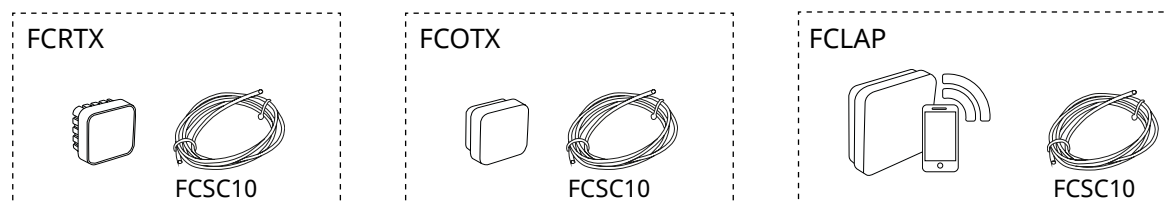

Item number	Type	Dimensions
74694	<b>FCRTX</b>	39x39x23 mm
74695	<b>FCOTX</b>	39x39x23 mm
74699	<b>FCLAP</b>	89x89x26 mm
74718	<b>FCBC05</b>	5 m
74719	<b>FCBC10</b>	10 m
74720	<b>FCBC25</b>	25 m
74721	<b>FCSC10</b>	10 m
74722	<b>FCSC25</b>	25 m
74703	<b>FCTXRF</b>	for FC Smart, FC Pro 89x89x26 mm



FCBC05/10/25  
FCSC10/25



FCTXRF

See separate manual for FC.

FR: L'aérotherme nécessite également un système de régulation FC.

DE: Der Heizlüfter muss durch ein FC-Steuerungssystem ergänzt werden.

SE: Värmeflåkten måste kompletteras med FC styrsystem.

NO: Varmluftsviften må suppleres med et FC-styringsystem.

DK: Varmeblæseren skal suppleres med en FC-styring.

FI: Puhallinlämmitin on varustettava FC-ohjausjärjestelmällä.

NL: De luchtverhitter moet worden aangevuld met een FC regelsysteem.

ES: El aerotermino debe complementarse con un sistema de control FC.

IT: Occorre integrare il termoventilatore con un sistema di regolazione FC.

PL: Nagrzewnicę należy wyposażyć w układ sterowania FC.

RU: Тепловентилятор должен быть дополнен системой управления FC.

## Technical specifications

### Panther FC 20 - 30 (IP44)

Item number	Type	Output steps [kW]	Airflow [m <sup>3</sup> /h]	Sound power * <sup>1</sup> [dB(A)]	Sound pressure* <sup>2</sup> [dB(A)]	Δt* <sup>3</sup> [°C]	Motor [W]	Voltage [V]	Amperage [A]	Weight [kg]
334031	<b>PNF20</b>	0/10/20	2250/2800	78	51/62	27/21	150	400V3N~* <sup>4</sup>	29,5	25
334032	<b>PNF2023</b>	0/10/20	2250/2800	78	51/62	27/21	150	230V3~	50,2	26,5
334033	<b>PNF30</b>	0/10/20/30	2250/2800	78	51/62	32/40	150	400V3N~* <sup>4</sup>	43,9	28
334035	<b>PNF3023</b>	0/10/20/30	2250/2800	78	51/62	32/40	150	230V3~	75,3	30

\*<sup>1</sup>) Sound power ( $L_{WA}$ ) measurements according to ISO 27327-2: 2014, Installation type E.

\*<sup>2</sup>) Sound pressure ( $L_{pA}$ ). Conditions: Distance to the unit 3 metres. Directional factor: 2. Equivalent absorption area: 200 m<sup>2</sup>. At lowest/highest airflow.

\*<sup>3</sup>) Δt = temperature rise of passing air at maximum heat output and lowest/highest airflow.

\*<sup>4</sup>) Approved for 380V/3ph/60Hz. Product performance for 380V/3ph/60Hz will differ from stated data.



### Ecodesign Regulation (EU) 2015/1188

Type	PNF20	PNF2023	PNF30	PNF3023
<b>Heat output</b>				
Nominal heat output [kW]	20	20	30	30
Minimum heat output [kW]	10	10	10	10
Maximum continuous heat output [kW]	20	20	30	30
<b>Auxiliary electricity consumption</b>				
At nominal heat output [kW]	0,004	0,004	0,004	0,004
At minimum heat output [kW]	0,004	0,004	0,004	0,004
In standby mode [kW]	0,0005	0,0005	0,0005	0,0005
<b>Features</b>				
Fan assisted output	Yes	Yes	Yes	Yes
Electronic room temperature control plus week timer	Yes	Yes	Yes	Yes
Room temperature control, with open window detection	Yes	Yes	Yes	Yes
Distance control option	Yes	Yes	Yes	Yes
Adaptive start control	Yes	Yes	Yes	Yes

**EN: For translation of the English texts used, see the respective language pages.**

FR: Pour la traduction des textes en anglais, consultez la page correspondante à la langue souhaitée.

DE: Für die Übersetzung der verwendeten Texte in englischer Sprache, siehe die entsprechenden Sprachseiten.

SE: För översättning av de engelska texter som används, se respektive språksidor.

NO: For oversettelse av de engelske tekstene, se de respektive språksidene.

DK: For oversættelse af de engelske tekster, se siderne for de respektive sprog.

FI: Suviulla olevien enlanninkielisten sanojen käännökset löytyvät ko. kielisivuilta.

NL: Voor een vertaling van de gebruikte Engelse teksten, zie de pagina's van de resp. taal.

ES: Consulte la traducción de los textos en inglés que las acompañan en las páginas del idioma correspondiente.

IT: Per le traduzioni dei testi scritti in inglese, vedere le pagine nelle diverse lingue.

PL: Tłumaczenie wykorzystanych tekstów angielskich znajduje się na odpowiednich stronach językowych.

RU: Перевод встречающегося там текста приведен в разделе RU.

Internal wiring diagram

Panther FC 20 kW 400V3N~

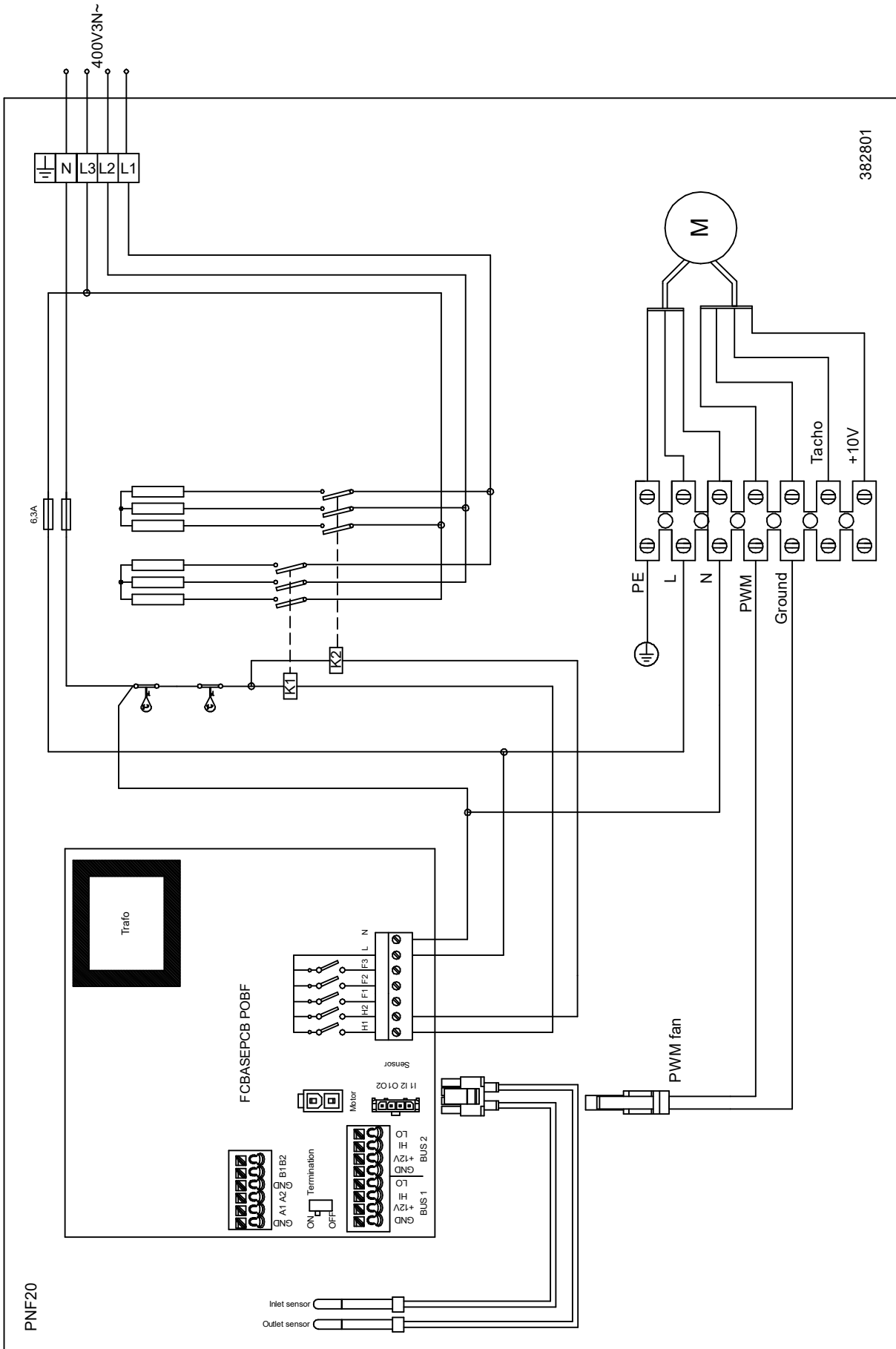

Wiring diagrams for control system in the FC manual.



Internal wiring diagram

Panther FC 30 kW 400V3N~

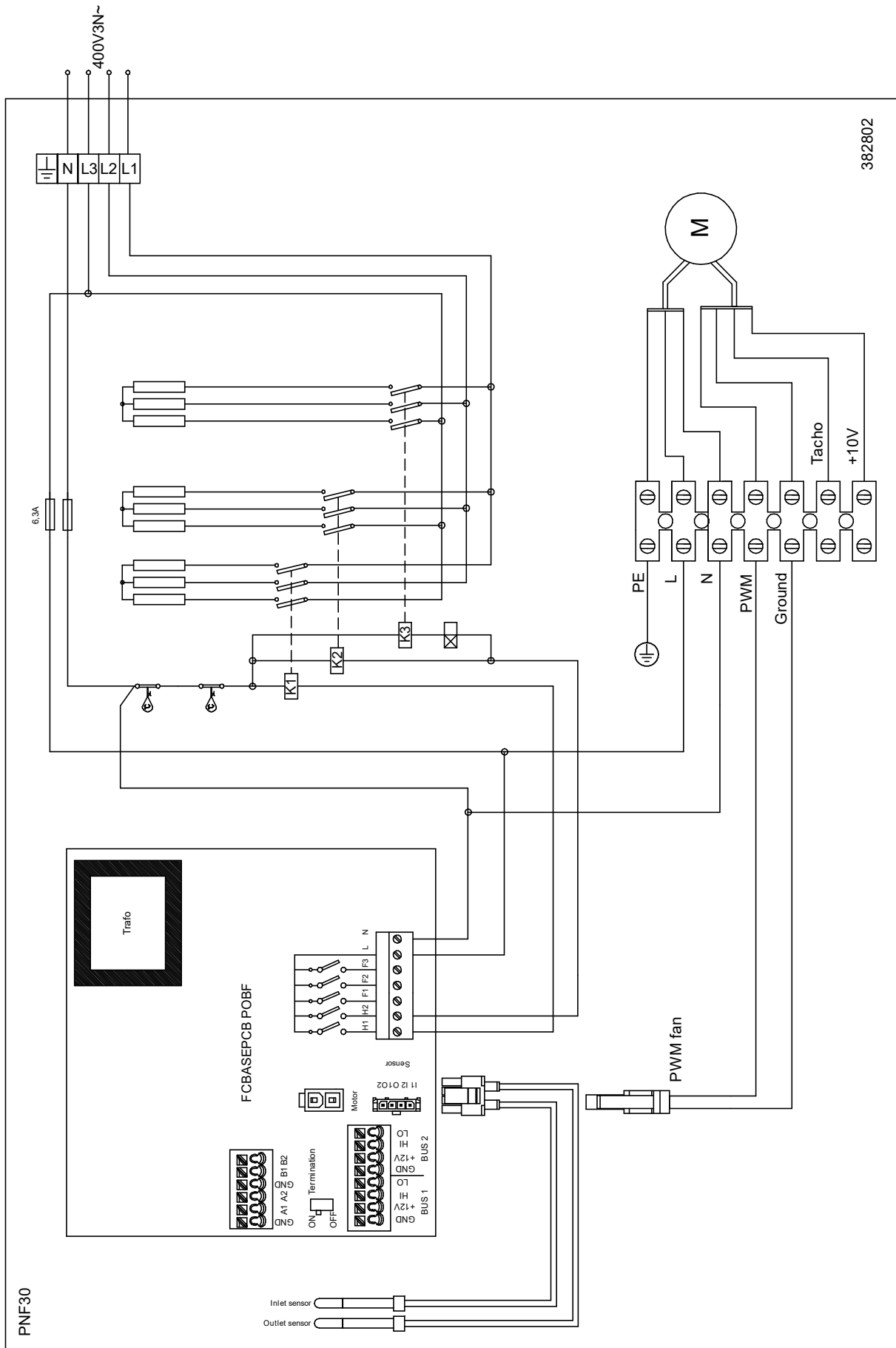

Wiring diagrams for control system in the FC manual.

Internal wiring diagram

Panther FC 20-30 kW 230V3~

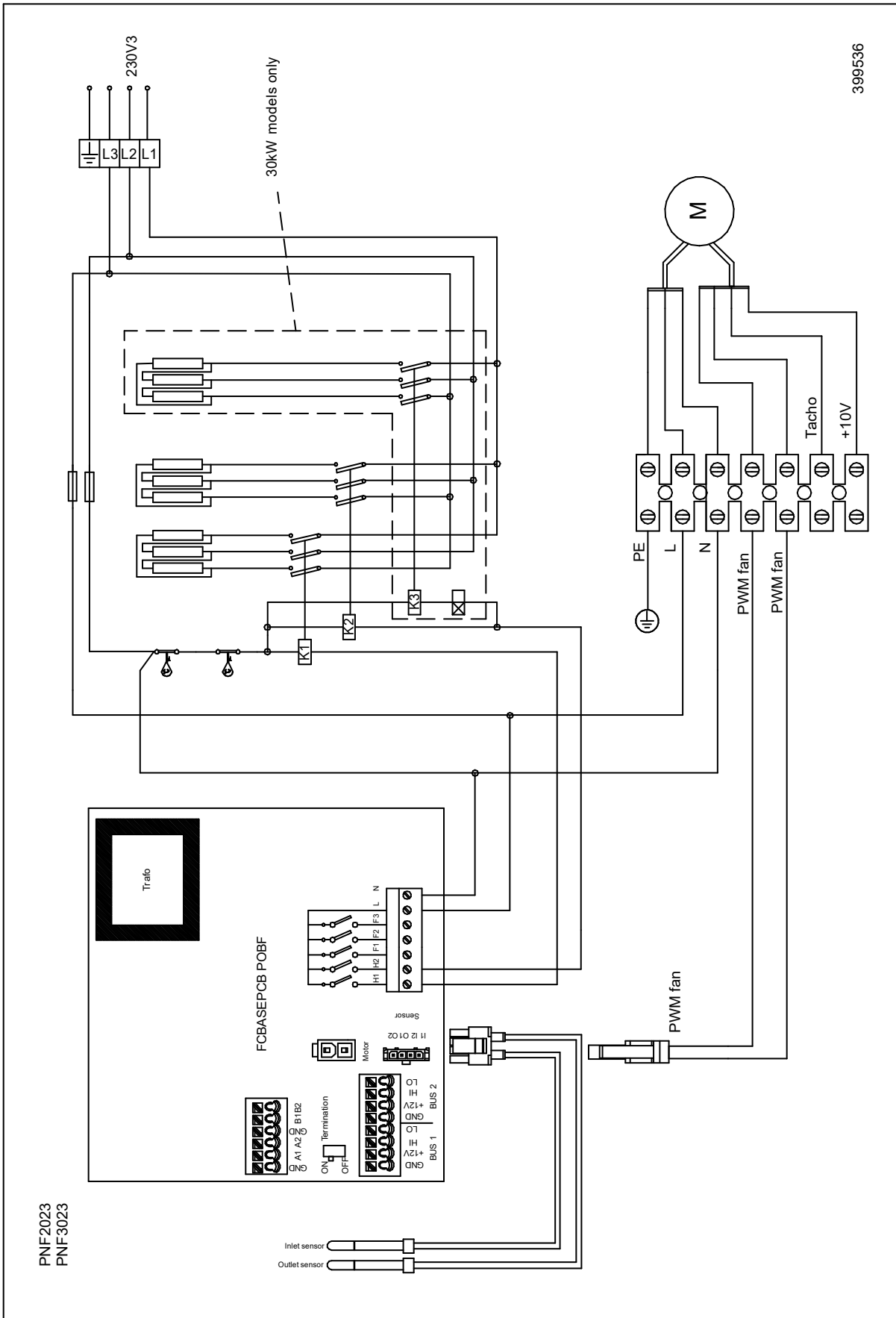

Wiring diagrams for control system in the FC manual.

## Installation and operating instructions

### General Instructions

Read these instructions carefully prior to installation and use. Keep this manual for future reference.

*The product may only be used as set out in the assembly and operating instructions. The guarantee is only valid should the product be used in the manner intended and in accordance with the instructions.*

### Application

Panther FC 20–30 is a range of powerful and quiet fan heaters intended for heating and drying in industrial premises and other large buildings. They are equipped with EC motor ensuring stepless airflow control. Protection class: IP44.

### Mounting

The Panther fan heater is mounted on the wall with the supplied bracket. The bracket allows the fan heater to be angled downwards and to the side (30° left or right). The product must be mounted in such a way as to allow future service and maintenance. For minimum distance, see diagrams on the introduction pages.

The bracket is fixed to the unit during transportation to not damage the unit.

1. Detach the bracket from the unit by removing the lower screws.
2. Mark and drill the holes for the bracket's keyhole slots on the wall.
3. Mount the bracket on the wall in the desired position (straight, to the left or to the right). Use screws and plugs suitable for the wall.
4. Loosen the upper screws of the unit approximately 10 mm and hang the unit on the bracket.
5. Adjust the fan heater to the desired angle and fasten it with the lower screws on both sides of the unit.
6. Tighten all screws.

See pictures in the introduction pages.



The power supply to the unit must be disconnected during all service, repair and maintenance work.

### Electrical installation

The Panther fan heater is intended for permanent installation. The installation, which should be preceded by an isolator switch with a contact separation of at least 3 mm, should only be wired by a competent electrician and in accordance with the latest edition of IEE wiring regulations.

The electrical connection is made on the back of the unit. Pierce the grommet with a screwdriver before entering the cable. Open the lid by removing its four screws to access the connection area. The wiring diagram can be found on the inside of the lid. Power supply should be connected to the assigned terminal block.

See wiring diagrams.

### Control

Panther FC is prepared for FC control system, available in several packages for different requirements. The FC packages are ordered separately. The fan heater has an integrated PC board which is connected to the selected external control system FC. Communication and sensor cables are connected to the PC board via grommets on the back of the unit.

Should more than one fan heater be controlled by a single FC, an additional communication cable FCBC per unit will be required.

Settings are made on the FC control panel. See manual for FC. FC will activate the after-run: when the heat is switched off, the fan will continue to run for a short while to cool the elements.

### Start-up

When the unit is used for the first time or after a long period of non-use, smoke or an odour may result from dust or dirt which has collected on the element. This is completely normal and disappears after a short time.

## Overheating

The fan heater is equipped with an overheat protection. If it is deployed due to overheating, reset as follows:

1. Disconnect the power supply with the isolator switch.
2. Determine the cause of overheating and rectify the fault.
3. Reset by opening the lid and pushing the red button on top of the overheat protection until a click sound is heard. See pictures in the introduction pages.
4. Put the lid back on and reconnect the heater.

*NOTE! All work inside the unit's connection area must be carried out by a qualified technician and with the power supply disconnected.*

## Maintenance

Since fan motors and other components are maintenance-free, no maintenance other than cleaning is necessary. The level of cleaning can vary depending on local conditions. Undertake cleaning at least twice a year. Inlet and exhaust grilles, impeller and elements can be vacuum cleaned or wiped using a damp cloth. Use a brush when vacuuming to prevent damaging sensitive parts. Avoid the use of strong alkaline or acidic cleaning agents.

## Residual current circuit breaker

When the installation is protected by means of a residual current circuit breaker, which trips when the appliance is connected, this may be due to moisture in the heating element. When an appliance containing a heater element has not been used for a long period or stored in a damp environment, moisture can enter the element.

This should not be seen as a fault, but is simply rectified by connecting the appliance to the main supply via a socket without a safety cut-out so that the moisture can be eliminated from the element. The drying time can vary from a few hours to a few days. As a preventive measure, the unit should occasionally be run for a short time when it is not being used for extended periods of time.

## Packaging

Packaging materials are chosen with consideration to the environment and are therefore recyclable.

## Handling of product at end of working life

This product may contain substances necessary for the functionality of the product but potentially dangerous for the environment. The product should not be disposed of mixed with general household waste but delivered to a designated collection point for environmental recycling. Please contact the local authority for further details of your nearest designated collection point.

## Safety

- *For all installations of electrically heated products a residual current circuit breaker 300 mA for fire protection must be used.*
- *Keep the areas around the air intake and exhaust grilles free from possible obstructions!*
- *The unit must not be fully or partially covered as overheating can result in a fire risk!*
- *The unit must not be placed directly under fixed wall sockets!*
- *This appliance can be used by children aged from 8 years and above and persons with reduced physical, sensory or mental capabilities or lack of experience and knowledge if they have been given supervision or instruction concerning use of the appliance in a safe way and understand the hazards involved. Children shall not play with the appliance. Cleaning and user maintenance shall not be made by children without supervision.*
- *Children of less than 3 years should be kept away unless continuously supervised.*
- *Children aged from 3 years and less than 8 years shall only switch on/off the appliance provided that it has been placed or installed in its intended normal operating position and they have been given supervision or instruction concerning use of the appliance in a safe way and understand the hazards involved.*
- *Children aged from 3 years and less than 8 years shall not plug in, regulate and clean the appliance or perform user maintenance.*

**CAUTION — Some parts of this product can become very hot and cause burns. Particular attention has to be given where children and vulnerable people are present.**



**Main office**

Frico AB  
Industrivägen 41  
SE-433 61 Sävedalen  
Sweden

Tel: +46 31 336 86 00  
mailbox@frico.se  
www.frico.net

**For latest updated information and information  
about your local contact: [www.frico.net](http://www.frico.net)**