

Original instructions

PA1508

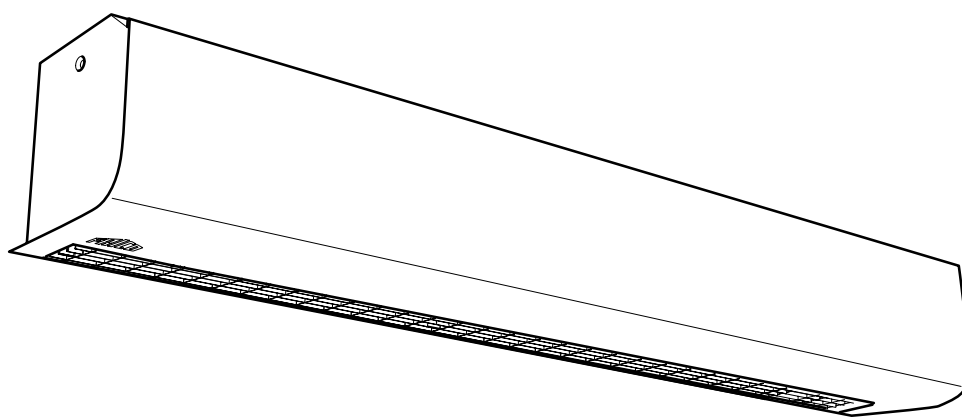

SE 9

EN ... 12

NO ... 14

DE ... 17

ES ... 20

FR ... 23

IT ... 26

NL ... 29

PL ... 32

RU ... 35

- SE** Introduktionssidorna består huvudsakligen av bilder. För översättning av de engelska texter som används, se respektive språksidor.
- EN** The introduction pages consist mainly of pictures. For translation of the English texts used, see the respective language pages.
- NO** Introduksjonssidene består hovedsakelig av bilder. For oversettelse av de engelske tekstene, se de respektive språksidene.
- FR** Les pages de présentation contiennent principalement des images. Pour la traduction des textes en anglais, consultez la page correspondante à la langue souhaitée.
- DE** Die Einleitungsseiten bestehen hauptsächlich aus Bildern. Für die Übersetzung der verwendeten Texte in englischer Sprache, siehe die entsprechenden Sprachseiten.
- ES** Las páginas introductorias contienen básicamente imágenes. Consulte la traducción de los textos en inglés que las acompañan en las páginas del idioma correspondiente.
- NL** De inleidende pagina's bevatten hoofdzakelijk afbeeldingen. Voor een vertaling van de gebruikte Engelse teksten, zie de pagina's van de resp. taal.
- IT** Le pagine introduttive contengono prevalentemente immagini. Per le traduzioni dei testi scritti in inglese, vedere le pagine nelle diverse lingue.
- PL** Początkowe strony zawierają głównie rysunki. Tłumaczenie wykorzystanych tekstów angielskich znajduje się na odpowiednich stronach językowych.
- RU** Страницы в начале Инструкции состоят в основном из рисунков, схем и таблиц. Перевод встречающегося там текста приведен в разделе RU.

PA1508

Dimensions

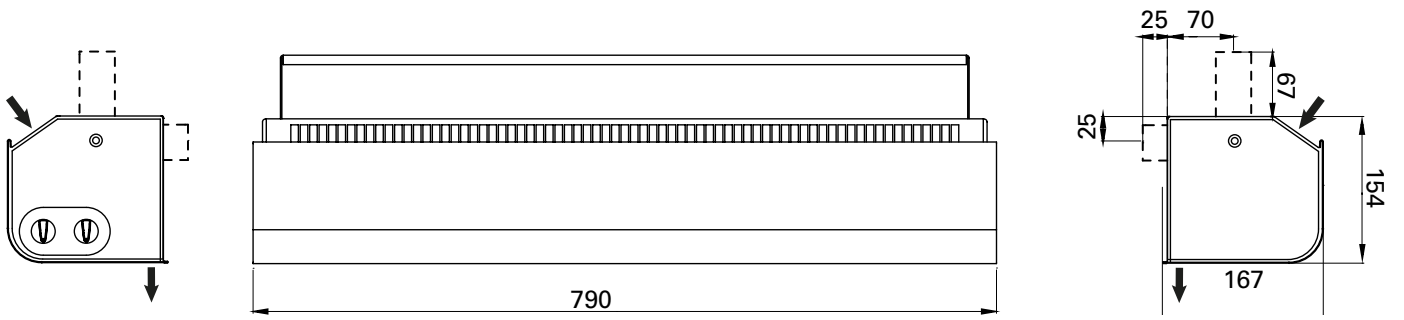

PA1508E02 / PA1508E03

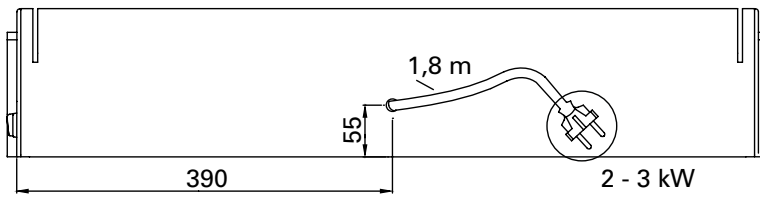

PA1508E05

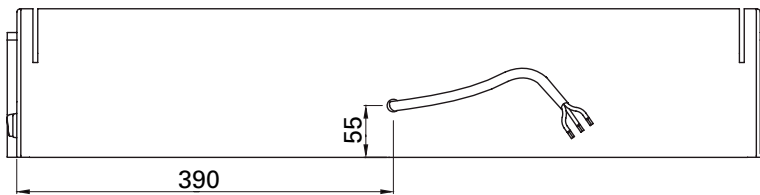

Mounting and installation

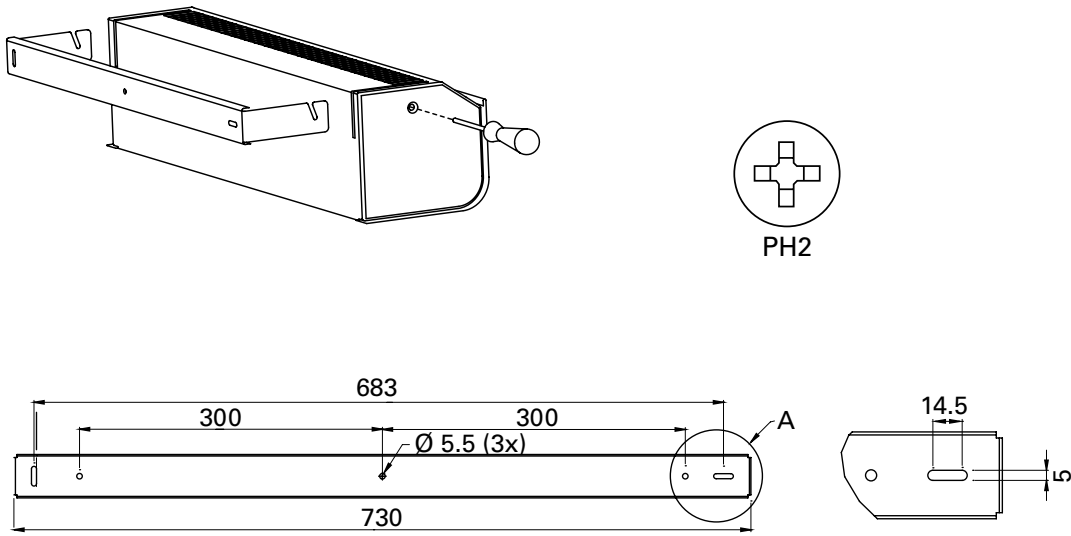

Fig. 1: Mounting bracket

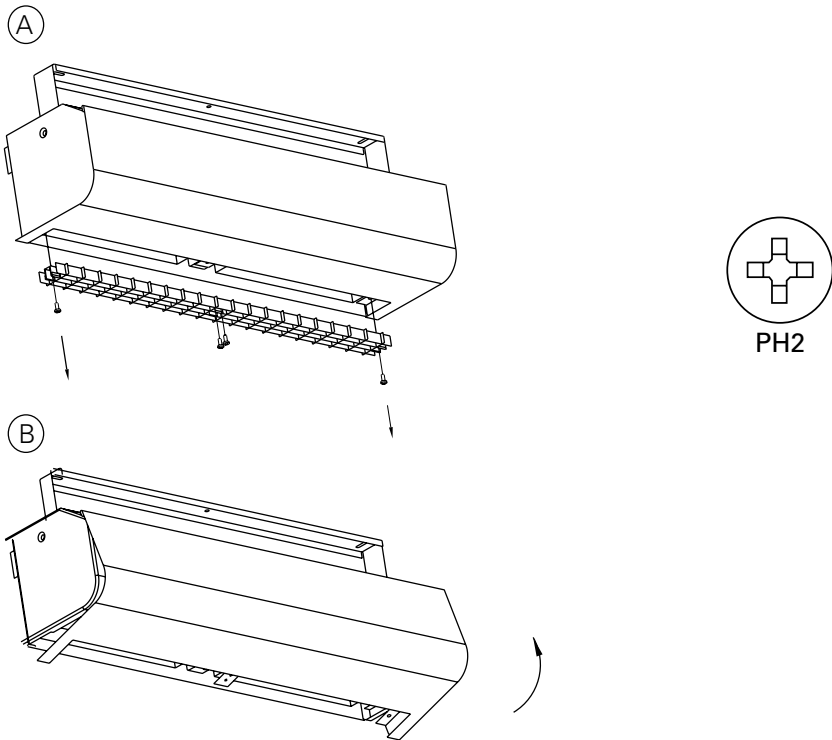
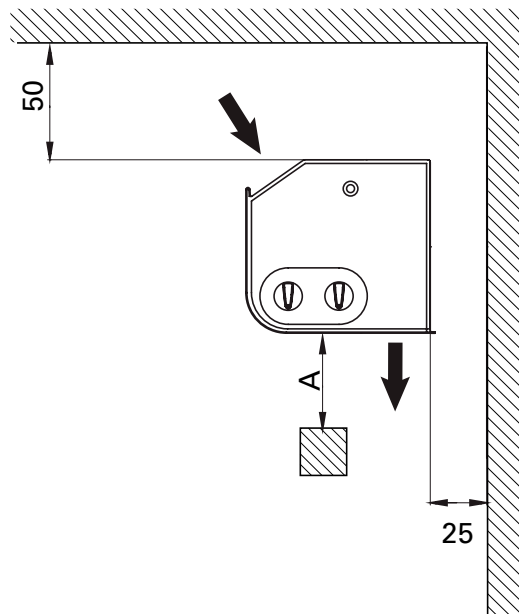
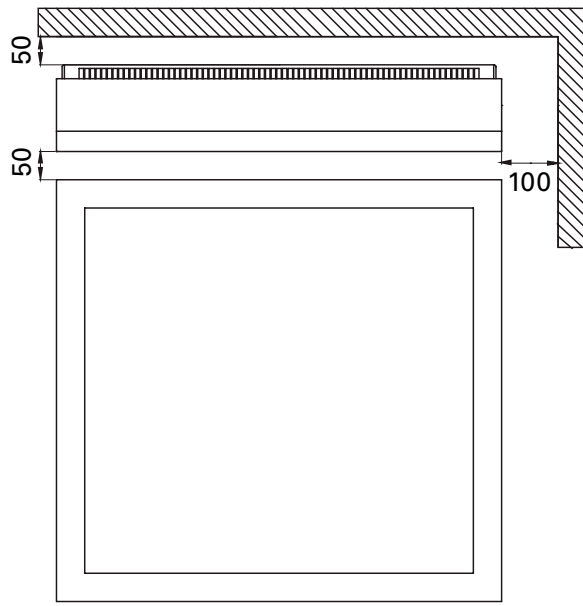

Fig. 2: Open the unit

Minimum distance



Flammable material	A 500
--------------------	-------

Fig. 3: Minimum distance

PA1508

PA1508E02

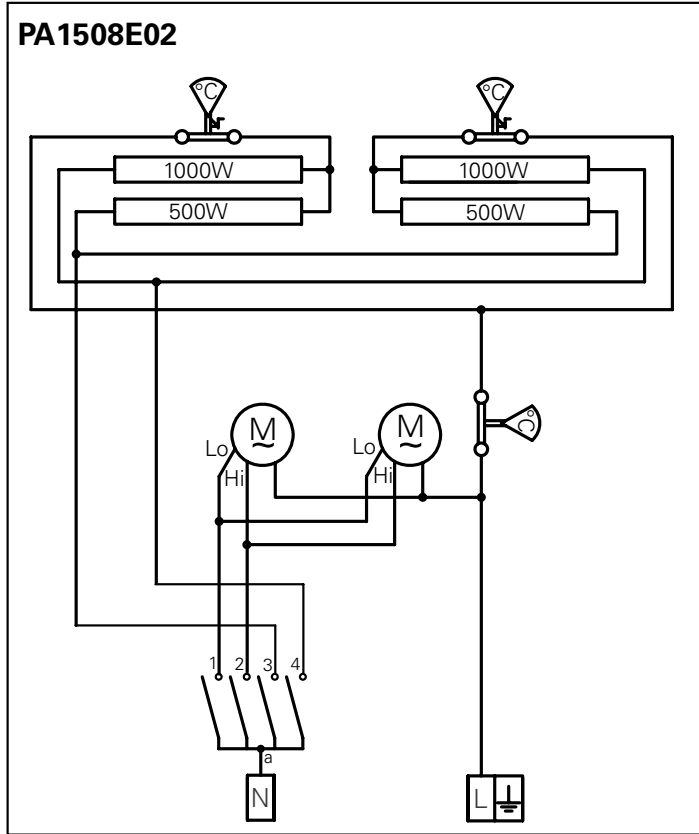

		a			
		1	2	3	4
0	OFF	0			
1	✕ + 1kW	✕ ■	○	○	
2	✕ + 2kW	✕ ■	○		○
3	✕ + 2kW	✕ ■	○	○	○

PA1508E03

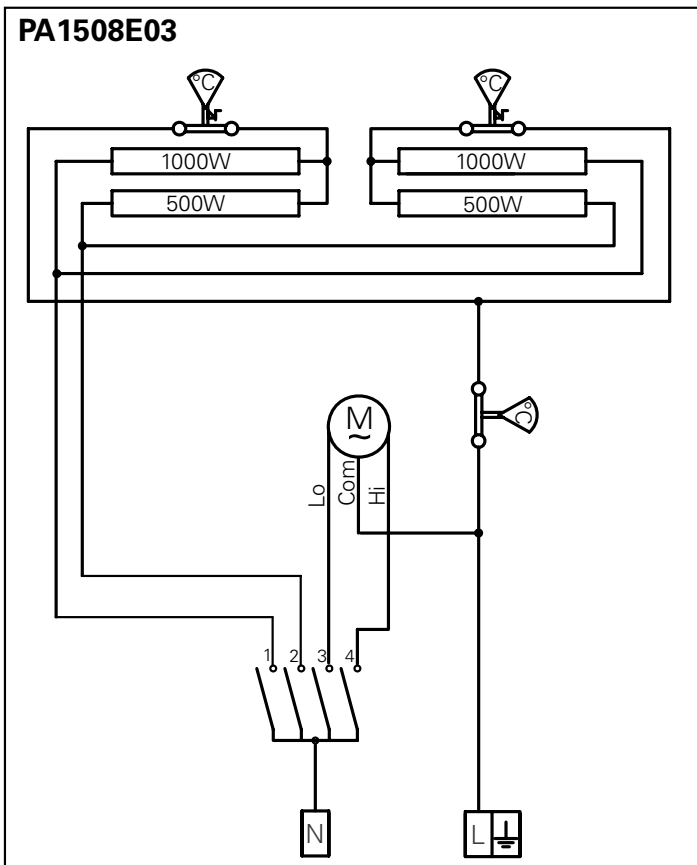

		a			
		1	2	3	4
0	OFF	0			
1	✕ + 2kW	✕ ■	○	○	
2	✕ + 2kW	✕ ■	○		○
3	✕ + 3kW	✕ ■	○	○	○

PA1508E05

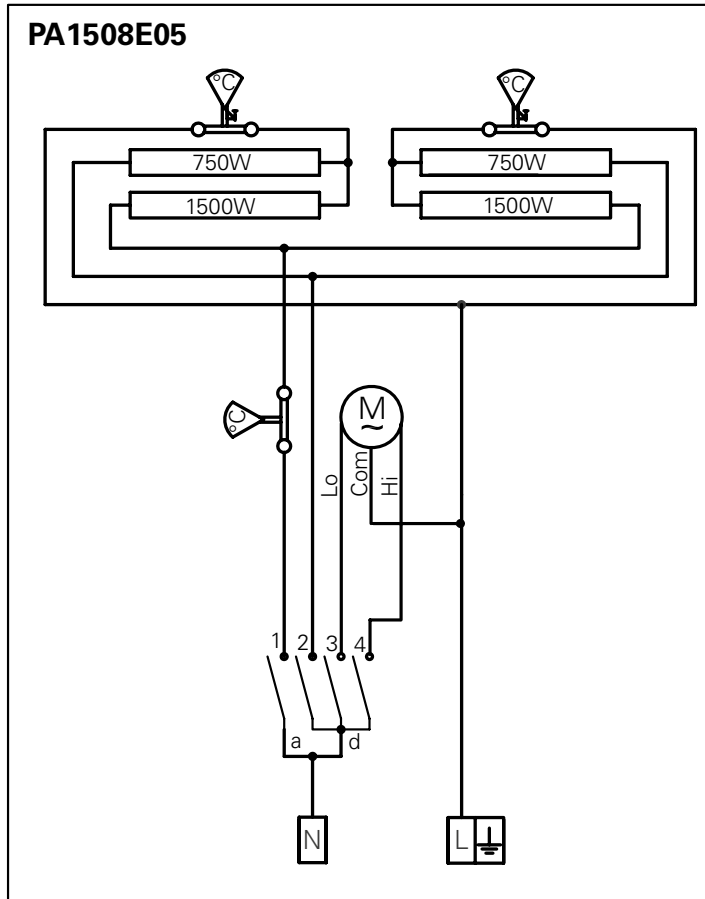

		a		d	
		1	2	3	4
0	OFF	0			
1	✘ + 3kW	✘ ■	○		○
2	✘ + 3kW	✘ ■	○		○
3	✘ + 4,5kW	✘ ■	○	○	○

Technical specifications

⚡ Electrical heat - PA1508

Type	Output step [kW]	Airflow [m ³ /h]	Δt^{*1} [°C]	Sound power ^{*2} [dB(A)]	Sound pressure ^{*3} [dB(A)]	Voltage [V]	Amperage (heat) [A]	Length [mm]	Weight [kg]
PA1508E02	1/2	270/400	22/15	66	39/50	230V~	8,7	790	7,5
PA1508E03	2/3	270/400	34/23	66	39/50	230V~	13,0	790	7,5
PA1508E05	3/4,5	270/400	51/34	66	39/50	230V~	19,6	790	7,5

*1) Δt = temperature rise of passing air at maximum heat output and lowest/highest airflow.

*2) Sound power (L_{WA}) measurements according to ISO 27327-2: 2014, Installation type E.

*3) Sound pressure (L_{pA}). Conditions: Distance to the unit 5 metres. Directional factor: 2. Equivalent absorption area: 200 m². At lowest/highest airflow.

Protection class: IP20

CE compliant.

Installation and operating instructions

General Instructions

Read these instructions carefully before installation and use. Keep this manual for future reference.

The product may only be used as set out in the assembly and operating instructions. The guarantee is only valid if the product is used in the manner intended and in accordance with the instructions.

Application

PA1508 is primarily intended for small openings such as kiosk and service hatches and cashier benches where a long, narrow air flow is required. This creates a temperature separating air barrier that prevents cold air from pushing in and hot air from flowing out. PA1508 also gives additional heat and in this way also improves the working environment. Protection class: IP20.

Operation

Air is drawn in at the top of the unit and blown out downwards so that it shields the opening and minimizes heat loss. To achieve the optimum curtain effect the unit must extend the full width of the opening.

The efficiency of the air curtain depends on the air temperature, pressure differences across the opening and any wind pressure. **NOTE! Negative pressure in the building considerably reduces the efficiency of the air curtain. The ventilation should therefore be balanced.**

Mounting

The air curtain is installed horizontally with the supply air grille facing downwards as close to the opening as possible. Minimum distance from outlet to floor is 1800 mm. For other minimum distances, see fig. 3. Bracket is supplied for wall or ceiling mounting. The unit can be tilted for optimum output.

1. Fit the bracket on the wall or on the ceiling.
2. Guide the unit onto the bracket through the opening at the rear or on top.
3. The unit is secured by guiding the slot in the bracket over the screw (PH2) inside the unit and then tightening the screw from outside of the unit.

See Fig. 1-3.

Electrical installation

The installation, which should be preceded by an omnipolar switch with a contact separation of at least 3 mm, should only be wired by a competent electrician and in accordance with the latest edition of IEE wiring regulations.

Units with 2-3 kW are supplied with a 1,8 m cable and plug. The socket for PA1508E03 must be fused for 16 A.







The PA1508E05 must be permanently connected to a fused mains supply using a cable of a minimum 4 mm² section. See wiring diagrams.

Control







The air curtain has a built-in thermostat for heat and switch to set the fan and heating steps.

Control settings:

PA1508E02

- 0 OFF
-   Low speed - 1 kW
-   Low speed - 2 kW
-   High speed - 2 kW

PA1508E03/PA1508E05

- 0 OFF
-   Low speed - 2/3 kW
-   High speed - 2/3 kW
-   High speed - 3/4,5 kW

Start-up (E)

When the unit is used for the first time or after a long period of disuse, smoke or odour may result from dust or dirt that has collected on the element. This is completely normal and disappears after a short time.

Service, repairs and maintenance

For all service, repair and maintenance first carry out the following:

1. Disconnect the power supply.
2. Loosen the screws on the intake grille and remove grille.
3. Lift the front.

See Fig.2.

Maintenance

Since fan motors and other components are maintenance free, no maintenance other than cleaning is necessary. The level of cleaning can vary depending on local conditions. Undertake cleaning at least twice a year. Inlet and exhaust grilles, impeller and elements can be vacuum cleaned or wiped using a damp cloth. Use a brush when vacuuming to prevent damaging sensitive parts. Avoid the use of strong alkaline or acidic cleaning agents.

Overheating

The air curtain unit with electric heater is equipped with an overheat protector. If it is deployed due to overheating, reset as follows:

1. Disconnect the electricity with the fully isolated switch.
2. Allow the electrical coil to cool.
3. Determine the cause of overheating and rectify the fault.
4. Once the overheat protector has cooled down the unit can be started again.

Trouble shooting

If the fans are not working or do not blow properly, check the following:

- The functions and settings of the built-in control system.
- That the intake grille is not dirty.

If there is no heat, check the following:

- The functions, internal sensor and settings of the built-in control system.

For units with electrical heating, also check the following:

- Power supply to electric heater coil; check fuses and circuit-breaker (if any).
- That the overheat protection for the motors has not been deployed.

If the fault cannot be rectified, please contact a qualified service technician.

Packaging

Packaging materials are chosen with consideration to environment and are therefore recyclable.

Handling of product at end of working life

This product may contain substances necessary for functionality of product but potentially dangerous for the environment. The product should not be disposed mixed with general household waste but delivered to a designated collection point for environmental recycling. Please contact local authority for further details of your nearest designated collection point.

Safety

- *For all installations of electrically heated products should a residual current circuit breaker 300 mA for fire protection be used.*
- *Keep the areas around the air intake and exhaust grilles free from possible obstructions!*
- *The unit must not be fully or partially covered as overheating can result in a fire risk!*
- *This appliance can be used by children aged from 8 years and above and persons with reduced physical, sensory or mental capabilities or lack of experience and knowledge if they have been given supervision or instruction concerning use of the appliance in a safe way and understand the hazards involved. Children shall not play with the appliance. Cleaning and user maintenance shall not be made by children without supervision.*
- *Children of less than 3 years should be kept away unless continuously supervised.*
- *Children aged from 3 years and less than 8 years shall only switch on/off the appliance provided that it has been placed or installed in its intended normal operating position and they have been given supervision or instruction concerning use of the appliance in a safe way and understand the hazards involved.*
- *Children aged from 3 years and less than 8 years shall not plug in, regulate and clean the appliance or perform user maintenance.*

CAUTION — Some parts of this product can become very hot and cause burns. Particular attention has to be given where children and vulnerable people are present.



Main office

Frico AB
Industrivägen 41
SE-433 61 Sävedalen
Sweden

Tel: +46 31 336 86 00

mailbox@frico.se
www.frico.net

**For latest updated information and information
about your local contact: www.frico.net.**