

Original instructions  
**PA3200C**

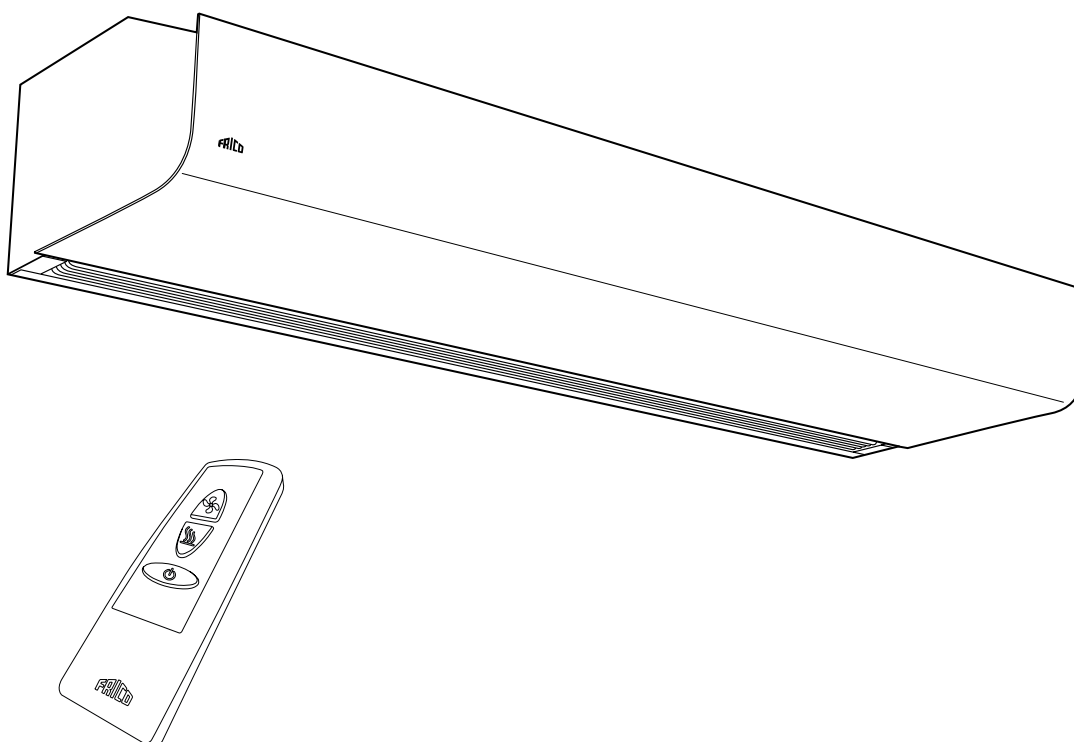

SE .... 16	EN .... 23	NO .... 29	DE .... 36	ES .... 43
FR .... 50	IT .... 57	NL .... 64	PL .... 71	RU .... 78
FI .... 85	DK .... 92			

- SE Introduktionssidorna består huvudsakligen av bilder. För översättning av de engelska texter som används, se respektive språksidor.
- EN The introduction pages consist mainly of pictures. For translation of the English texts used, see the respective language pages.
- NO Introduksjonssidene består hovedsakelig av bilder. For oversettelse av de engelske tekstene, se de respektive språksidene.
- FR Les pages de présentation contiennent principalement des images. Pour la traduction des textes en anglais, consultez la page correspondante à la langue souhaitée.
- DE Die Einleitungsseiten bestehen hauptsächlich aus Bildern. Für die Übersetzung der verwendeten Texte in englischer Sprache, siehe die entsprechenden Sprachseiten.
- ES Las páginas introductorias contienen básicamente imágenes. Consulte la traducción de los textos en inglés que las acompañan en las páginas del idioma correspondiente.
- NL De inleidende pagina's bevatten hoofdzakelijk afbeeldingen. Voor een vertaling van de gebruikte Engelse teksten, zie de pagina's van de resp. taal.
- IT Le pagine introduttive contengono prevalentemente immagini. Per le traduzioni dei testi scritti in inglese, vedere le pagine nelle diverse lingue.
- PL Początkowe strony zawierają głównie rysunki. Tłumaczenie wykorzystanych tekstów angielskich znajduje się na odpowiednich stronach językowych.
- RU Страницы в начале Инструкции состоят в основном из рисунков, схем и таблиц. Перевод встречающегося там текста приведен в разделе RU.
- FI Esittelysivut koostuvat lähinnä kuvista. Suvuilla olevien englanninkielisten sanojen käännökset löytyvät ko. kielisivuilta.
- DK Introduktionssiderne består hovedsageligt af billeder. For oversættelse af de engelske tekster, se siderne for de respektive sprog.

# PA3200C

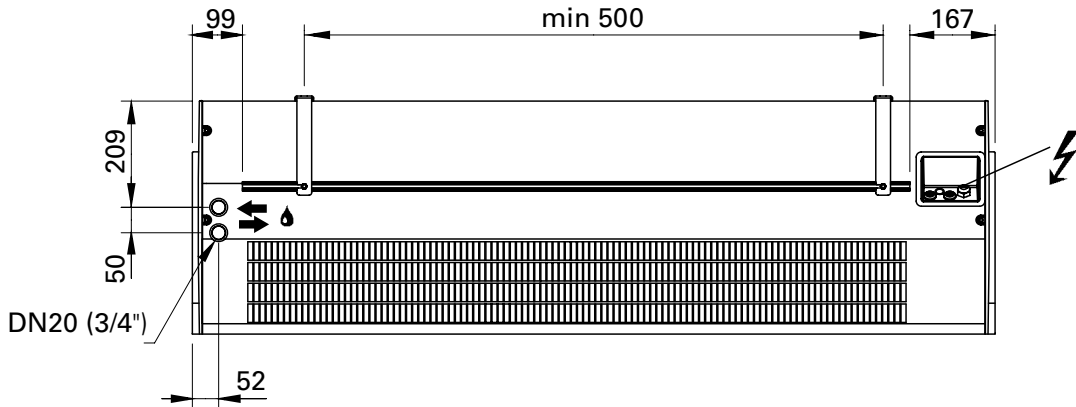
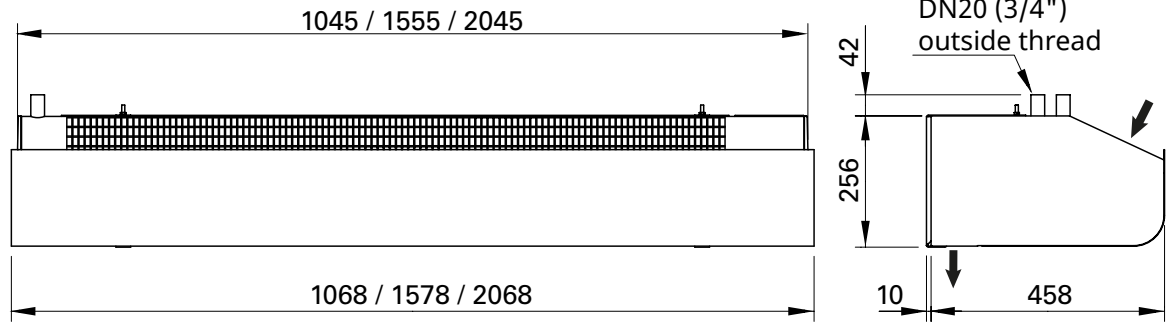

L = 2 m

A / W

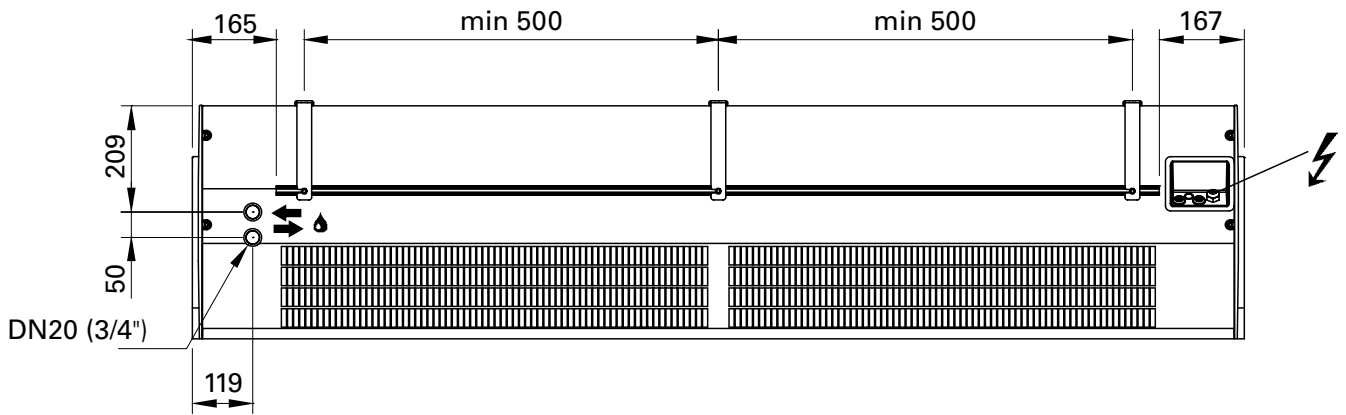

E

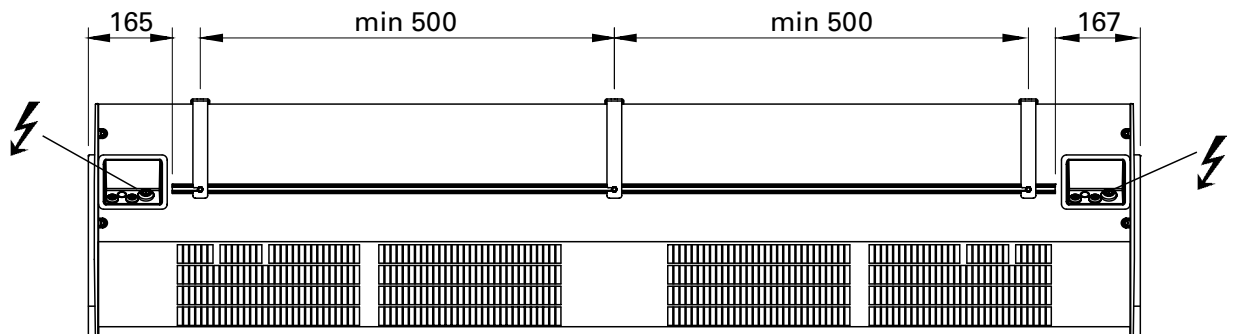

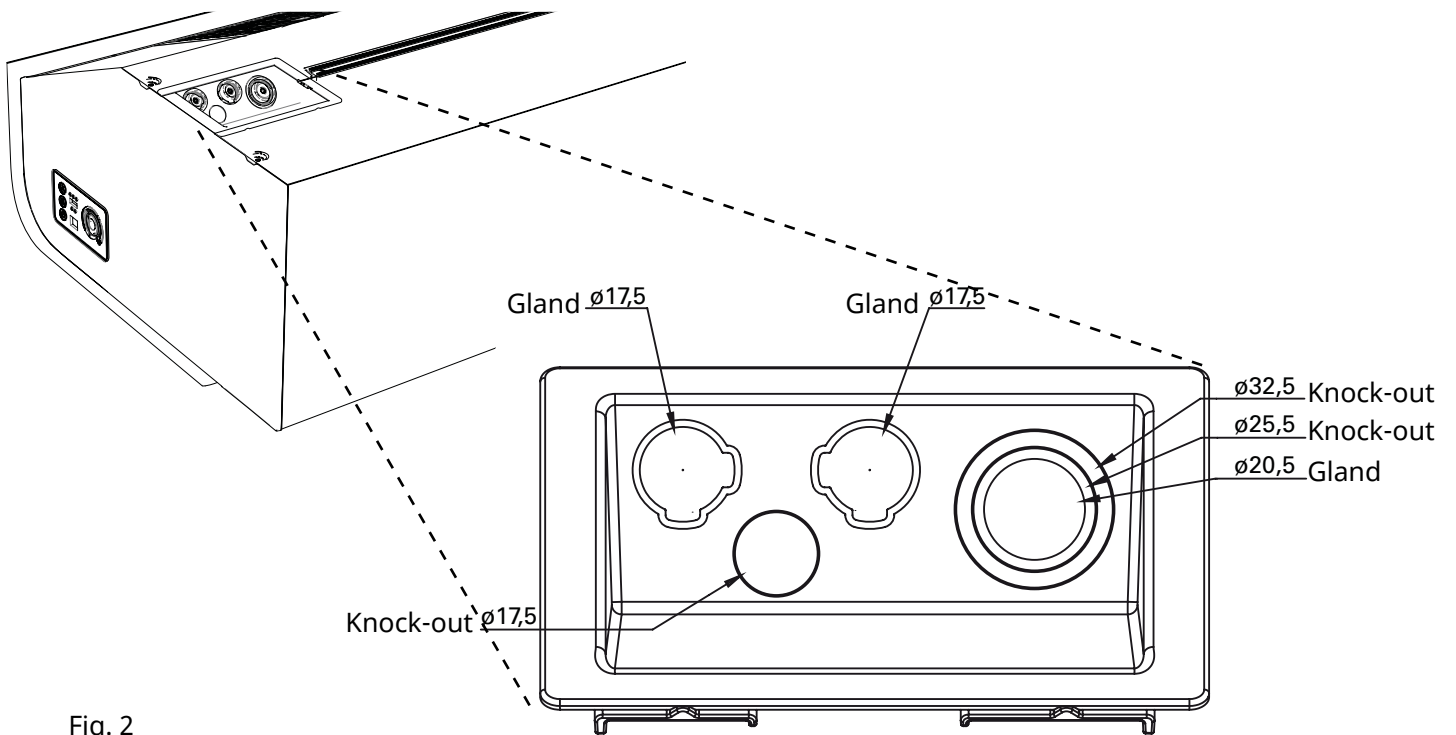

Fig. 2

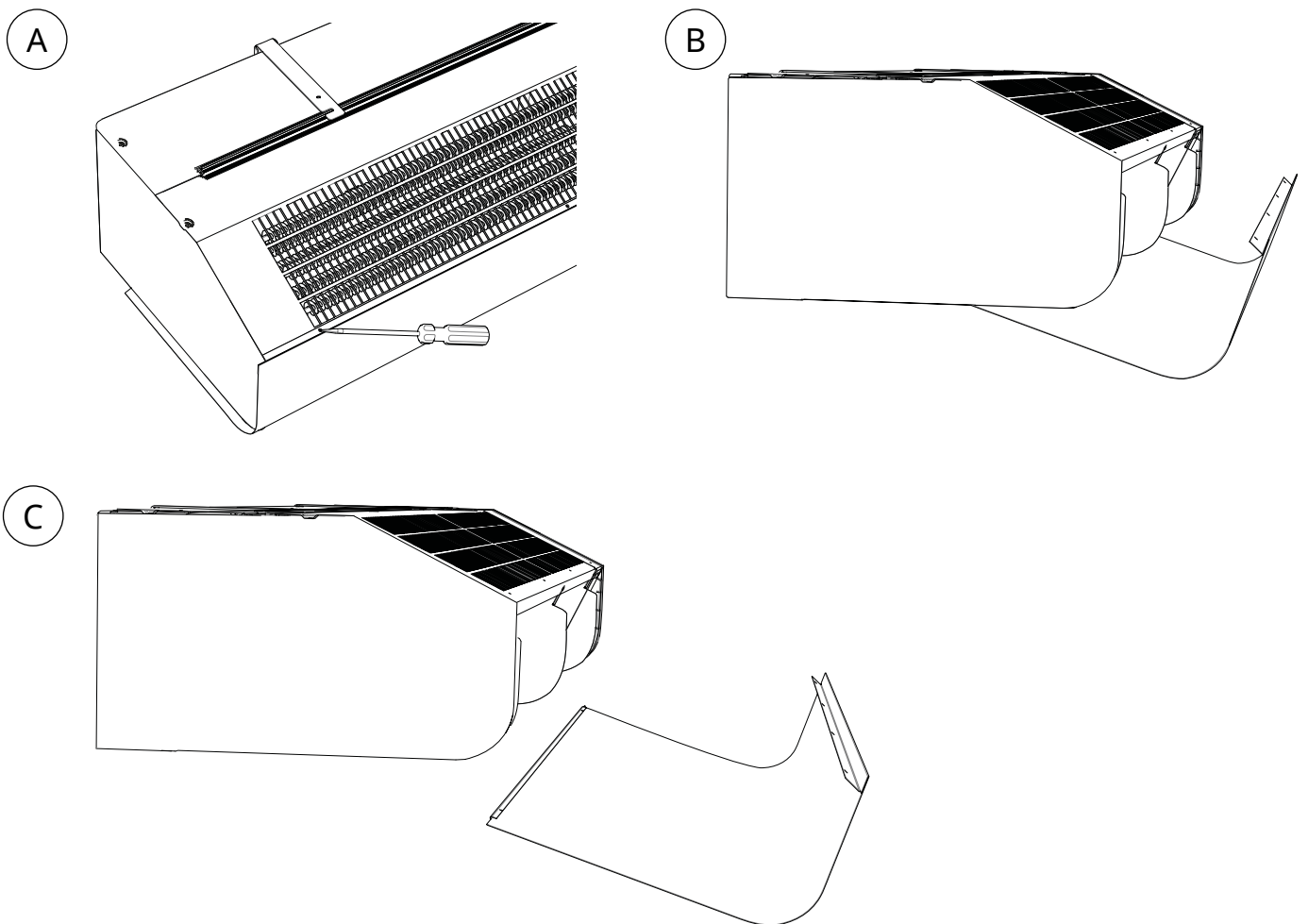

Fig. 3: Open the unit.

Minimum distance

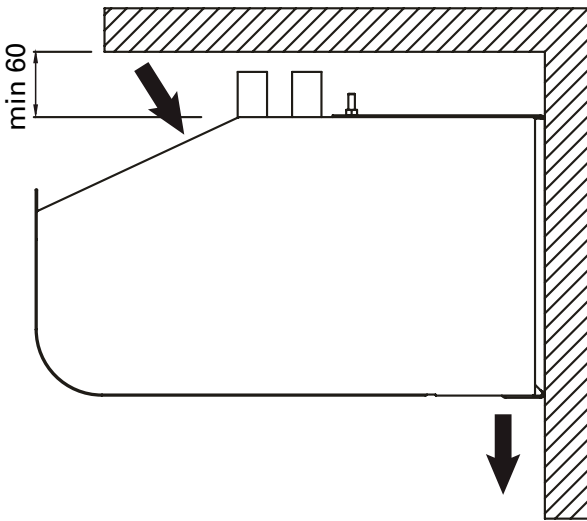

Fig. 4

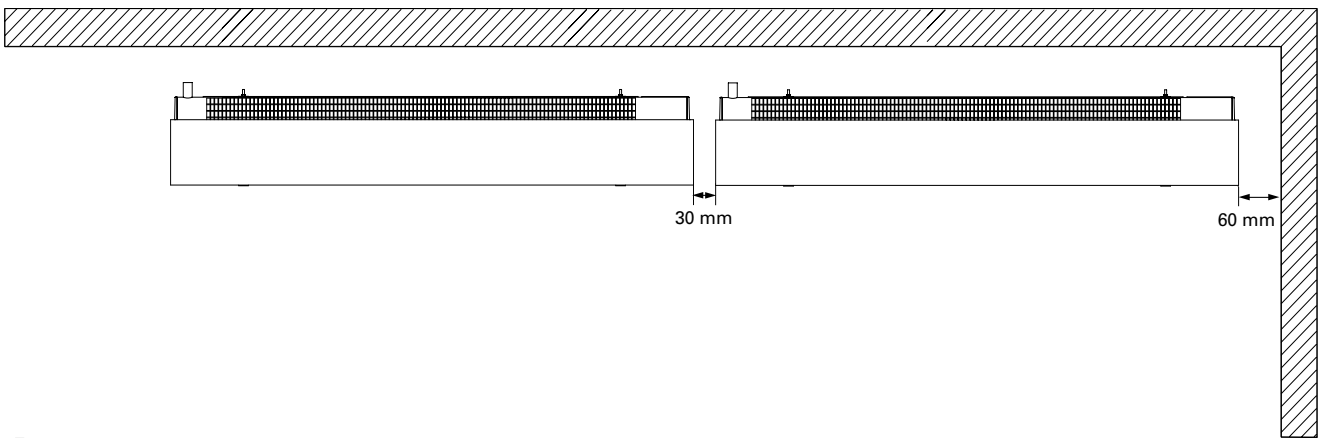

Fig. 5

Mounting with wall brackets

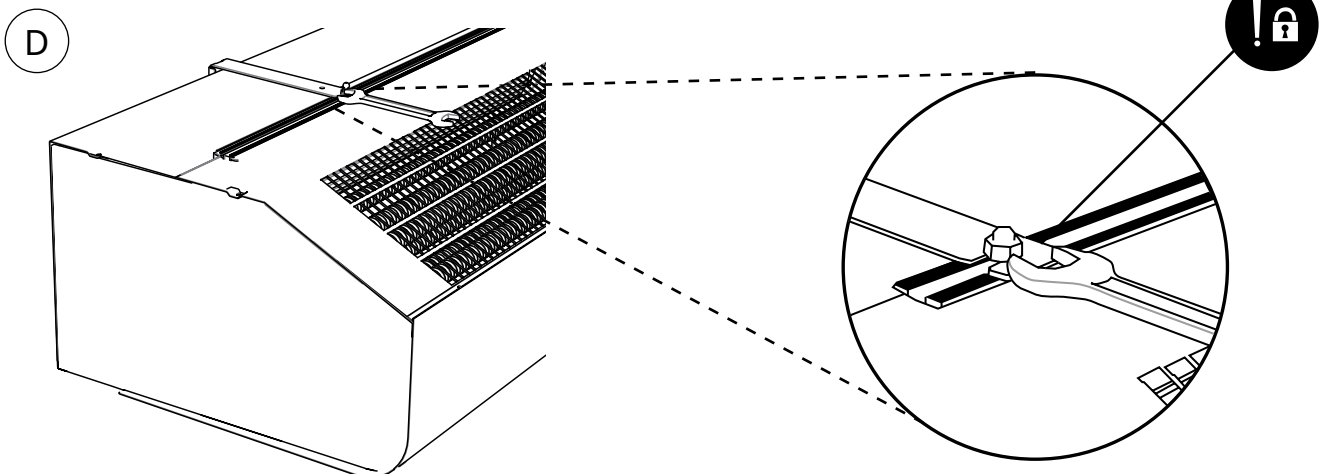
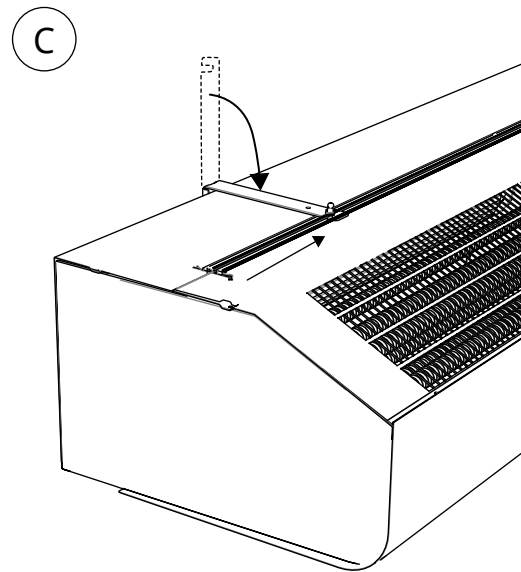
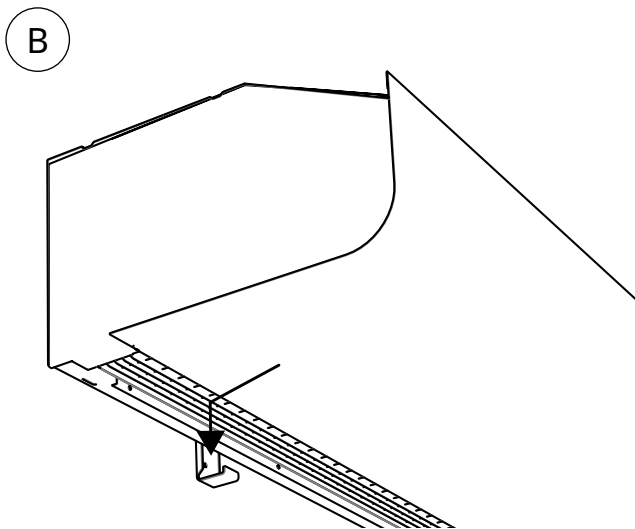
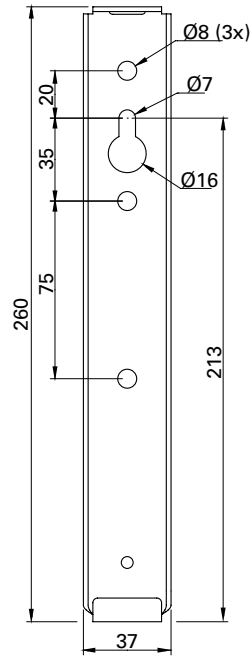
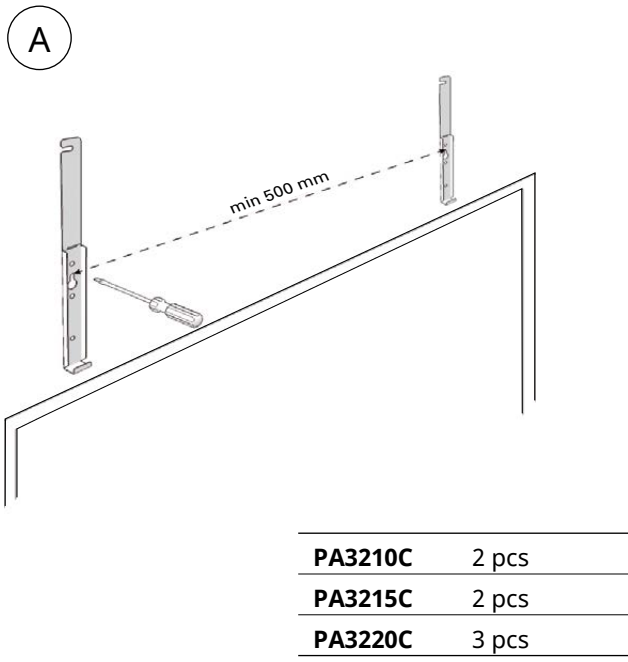
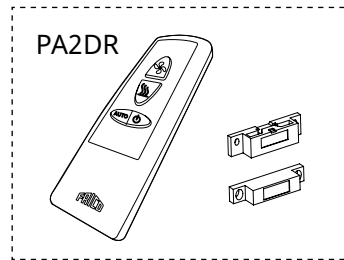
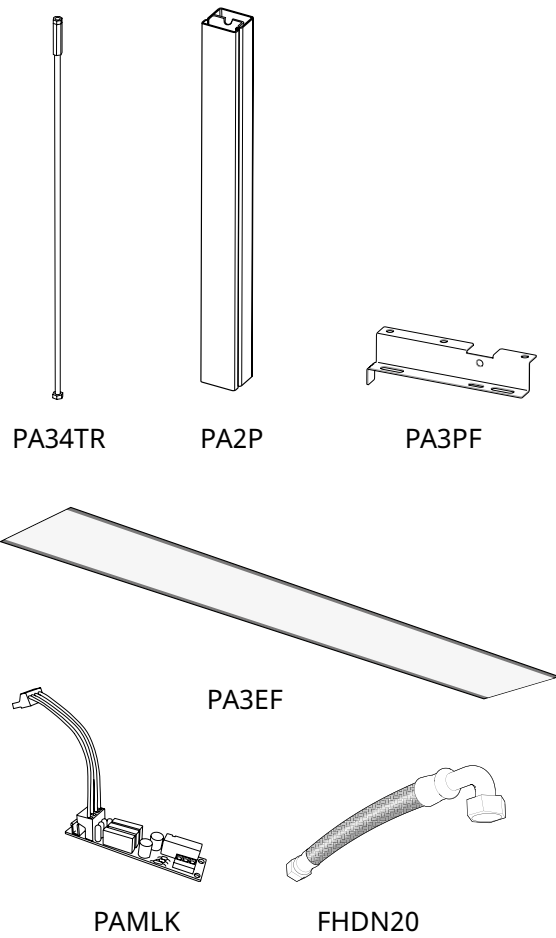

Fig. 6: Mounting with wall brackets

Accessories

<b>PA34TR15</b>	PA3210C, PA3215C, 1 m
<b>PA34TR20</b>	PA3220C, 1 m
<b>PA2P15</b>	PA3210C, PA3215C, 1 m
<b>PA2P20</b>	PA3220C, 1 m
<b>PA3PF15</b>	PA3210C, PA3215C
<b>PA3PF20</b>	PA3220C
<b>PAMLK</b>	PA3200C
<b>PA3EF10</b>	PA3210C W
<b>PA3EF15</b>	PA3215C W
<b>PA3EF20</b>	PA3220C W
<b>FHDN20</b>	PA3200C W



PA2DR



<b>VLSP15LF</b>	DN15
<b>VLSP15NF</b>	DN15
<b>VLSP20</b>	DN20
<b>VLSP25</b>	DN25
<b>VLSP32</b>	DN32
<b>VOT15</b>	DN15
<b>VOT20</b>	DN20
<b>VOT25</b>	DN25

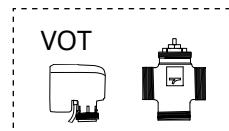
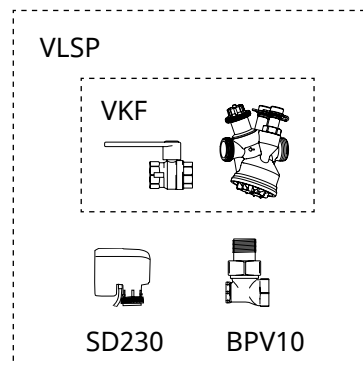

## ✦ Ambient, no heat - PA3200C A (IP21)

Type	Output [kW]	Airflow* <sup>1</sup> [m <sup>3</sup> /h]	Sound power* <sup>2</sup> [dB(A)]	Sound pressure* <sup>3</sup> [dB(A)]	Voltage motor [V]	Amperage motor [A]	Length [mm]	Weight [kg]
PA3210CA	0	1100/1750	73	46/57	230V~	0,7	1068	22
PA3215CA	0	1700/2750	74	46/59	230V~	1,0	1578	32
PA3220CA	0	2300/3500	75	50/60	230V~	1,3	2068	42

## ⚡ Electrical heat - PA3200C E (IP20)

Type	Output steps [kW]	Airflow* <sup>1</sup> [m <sup>3</sup> /h]	$\Delta t$ * <sup>4</sup> [°C]	Sound power* <sup>2</sup> [dB(A)]	Sound pressure* <sup>3</sup> [dB(A)]	Amperage motor [A]	Voltage [V] Amperage [A] (heat)	Length [mm]	Weight [kg]
PA3210CE08	5/8	1100/1750	22/13	72	46/57	0,65	400V3N~/11,5	1068	26
PA3215CE12	8/12	1700/2750	21/13	75	46/59	1,0	400V3N~/17,3	1578	37
PA3220CE16	10/16	2300/3500	22/13	76	50/60	1,3	400V3N~/23,1	2068	51

## ⚡ Electrical heat 230V3~ - PA3200C E (IP20)

Type	Output step [kW]	Airflow* <sup>1</sup> [m <sup>3</sup> /h]	$\Delta t$ * <sup>4</sup> [°C]	Sound power* <sup>2</sup> [dB(A)]	Sound pressure* <sup>3</sup> [dB(A)]	Amp. motor [A]	Voltage heat [V]	Amp. heat [A]	Length [mm]	Weight [kg]
PA3210CE08YD	5/8	1100/1750	22/13	72	46/57	0,65	230V3~/400VN3~	20,1/11,5	1068	26
PA3215CE12YD	8/12	1700/2750	21/13	75	46/59	1,0	230V3~/400VN3~	30,1/17,3	1578	37
PA3220CE16YD	10/16	2300/3500	22/13	76	50/60	1,3	230V3~/400VN3~	40,2/23,1	2068	51

## 💧 Water heat - PA3200C W (IP21)

Type	Output* <sup>5</sup> [kW]	Airflow* <sup>1</sup> [m <sup>3</sup> /h]	$\Delta t$ * <sup>4,5</sup> [°C]	Water volume [l]	Sound power* <sup>2</sup> [dB(A)]	Sound pressure* <sup>3</sup> [dB(A)]	Amperage motor [A]	Length [mm]	Weight [kg]
PA3210CW	8	1050/1700	16/14	1,3	70	45/55	0,65	1068	26
PA3215CW	14	1850/2700	17/15	2,1	73	46/57	0,7	1578	36
PA3220CW	18	2200/3300	18/16	2,7	74	49/58	1,3	2068	48

\*<sup>1</sup>) Lowest/highest airflow of totally 3 fan steps.

\*<sup>2</sup>) Sound power ( $L_{WA}$ ) measurements according to ISO 27327-2: 2014, Installation type E.

\*<sup>3</sup>) Sound pressure ( $L_{pA}$ ). Conditions: Distance to the unit 5 metres. Directional factor: 2. Equivalent absorption area: 200 m<sup>2</sup>. At lowest/highest airflow.

\*<sup>4</sup>)  $\Delta t$  = temperature rise of passing air at maximum heat output and lowest/highest airflow.

\*<sup>5</sup>) Applicable at water temperature 60/40 °C, air temperature, in +18 °C.

Protection class for units with electrical heating: IP20.

Protection class for units without heating and units with water heating: IP21.

CE compliant.





## Output charts water PA3200C

			Supply water temperature: 80 °C Room temperature: +18 °C Outlet air temperature: +35 °C*1				Water temperature: 80/60 °C Room temperature: +18 °C			
Type	Fan position	Airflow [m³/h]	Output [kW]	Return water temp. [°C]	Water flow [l/s]	Pressure drop [kPa]	Output *2 [kW]	Outlet air temp. [°C]	Water flow [l/s]	Pressure drop [kPa]
PA3210CW	max	1700	9,8	42	0,06	1,4	14,6	43	0,18	8,5
	min	1050	6,2	38	0,04	0,5	10,6	48	0,13	4,8
PA3215CW	max	2700	15,6	38	0,09	2,0	24,7	45	0,30	16,8
	min	1850	10,5	34	0,06	0,9	19,2	49	0,23	10,6
PA3220CW	max	3300	18,6	36	0,10	1,9	31,2	46	0,38	19,0
	min	2200	12,6	34	0,07	0,9	23,7	50	0,29	11,5

			Supply water temperature: 70 °C Room temperature: +18 °C Outlet air temperature: +35 °C*1				Water temperature: 70/50 °C Room temperature: +18 °C			
Type	Fan position	Airflow [m³/h]	Output [kW]	Return water temp. [°C]	Water flow [l/s]	Pressure drop [kPa]	Output *2 [kW]	Outlet air temp. [°C]	Water flow [l/s]	Pressure drop [kPa]
PA3210CW	max	1700	9,7	44	0,09	2,7	11,3	38	0,14	5,5
	min	1050	6,1	39	0,05	0,9	8,3	41	0,10	3,2
PA3215CW	max	2700	15,6	41	0,13	3,9	19,4	39	0,24	11,1
	min	1850	11,0	38	0,08	1,7	15,0	42	0,18	7,0
PA3220CW	max	3300	18,9	39	0,15	3,7	24,4	40	0,30	12,5
	min	2200	12,9	36	0,09	1,6	18,6	43	0,23	7,6

			Supply water temperature: 60 °C Room temperature: +18 °C Outlet air temperature: +35 °C*1				Water temperature: 60/40 °C Room temperature: +18 °C			
Type	Fan position	Airflow [m³/h]	Output [kW]	Return water temp. [°C]	Water flow [l/s]	Pressure drop [kPa]	Output *2 [kW]	Outlet air temp. [°C]	Water flow [l/s]	Pressure drop [kPa]
PA3210CW	max	1700	10,0	48	0,19	10,5	8,0	32	0,10	3,1
	min	1050	6,1	41	0,08	2,1	5,8	34	0,07	1,8
PA3215CW	max	2700	16,0	45	0,26	13,4	13,9	33	0,17	6,3
	min	1850	10,8	40	0,13	4,0	10,8	35	0,13	4,0
PA3220CW	max	3300	18,9	42	0,26	10,2	17,6	34	0,21	7,1
	min	2200	12,9	39	0,15	3,6	13,4	36	0,16	4,4

			Supply water temperature: 55 °C Room temperature: +18 °C Outlet air temperature: +35 °C*1				Water temperature: 55/35 °C Room temperature: +18 °C			
Type	Fan position	Airflow [m³/h]	Output [kW]	Return water temp. [°C]	Water flow [l/s]	Pressure drop [kPa]	Output *2 [kW]	Outlet air temp. [°C]	Water flow [l/s]	Pressure drop [kPa]
PA3210CW	max	1700	9,8	48	0,35	31,3	6,3	29	0,08	2,1
	min	1050	5,9	42	0,11	3,6	4,6	31	0,06	1,2
PA3215CW	max	2700	15,7	46	0,42	32,9	11,2	30	0,14	4,3
	min	1850	10,8	42	0,19	8,1	8,7	32	0,11	2,8
PA3220CW	max	3300	18,7	44	0,40	22,4	14,1	31	0,17	4,9
	min	2200	12,5	39	0,19	5,9	10,7	32	0,13	3,0

\*1) Recommended outlet air temperature for good comfort and optimized output.

\*2) Nominal output at given supply and return water temperature.

# PA3200C

PA3210CA / PA3215CA / PA3220CA

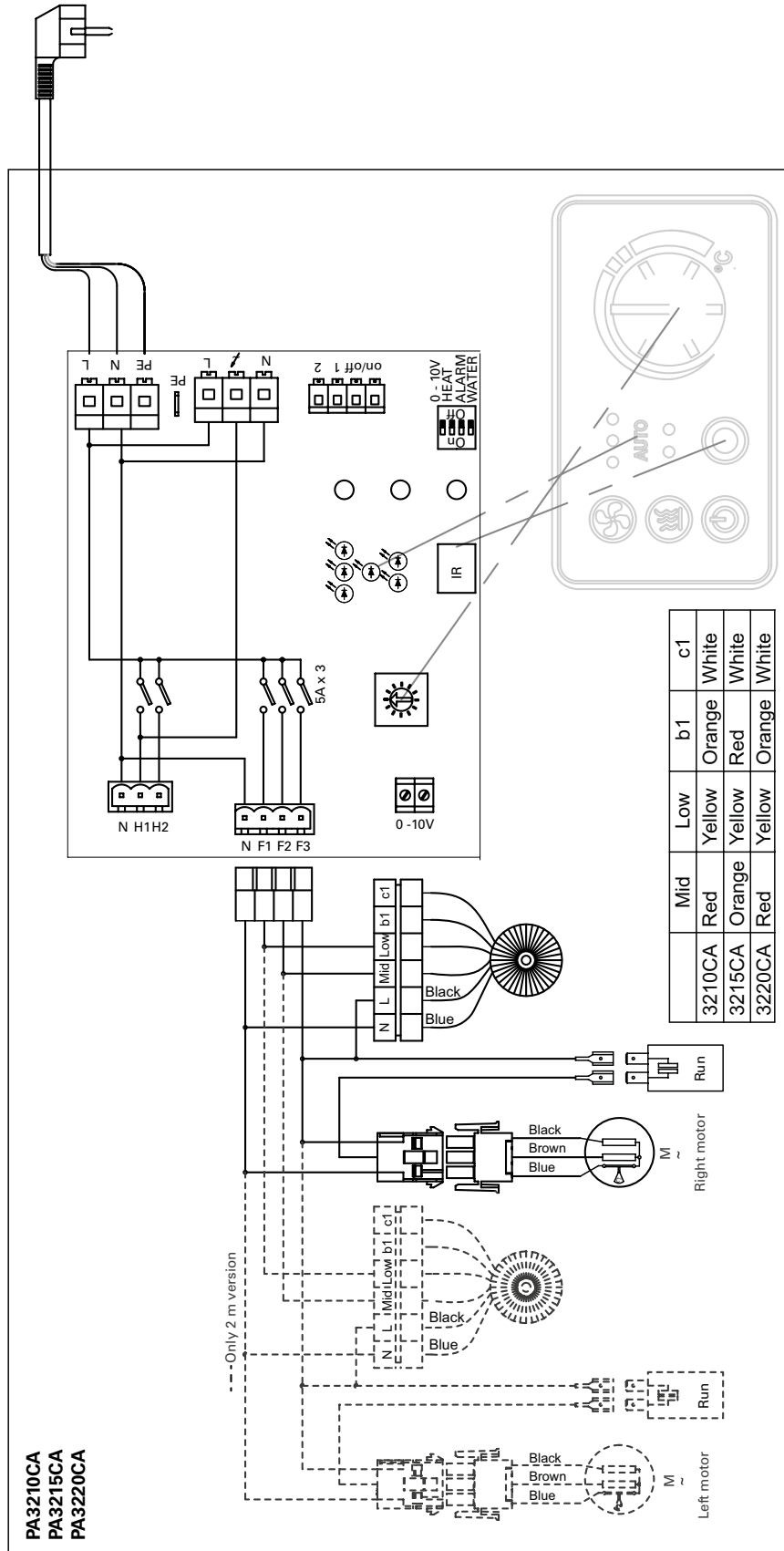

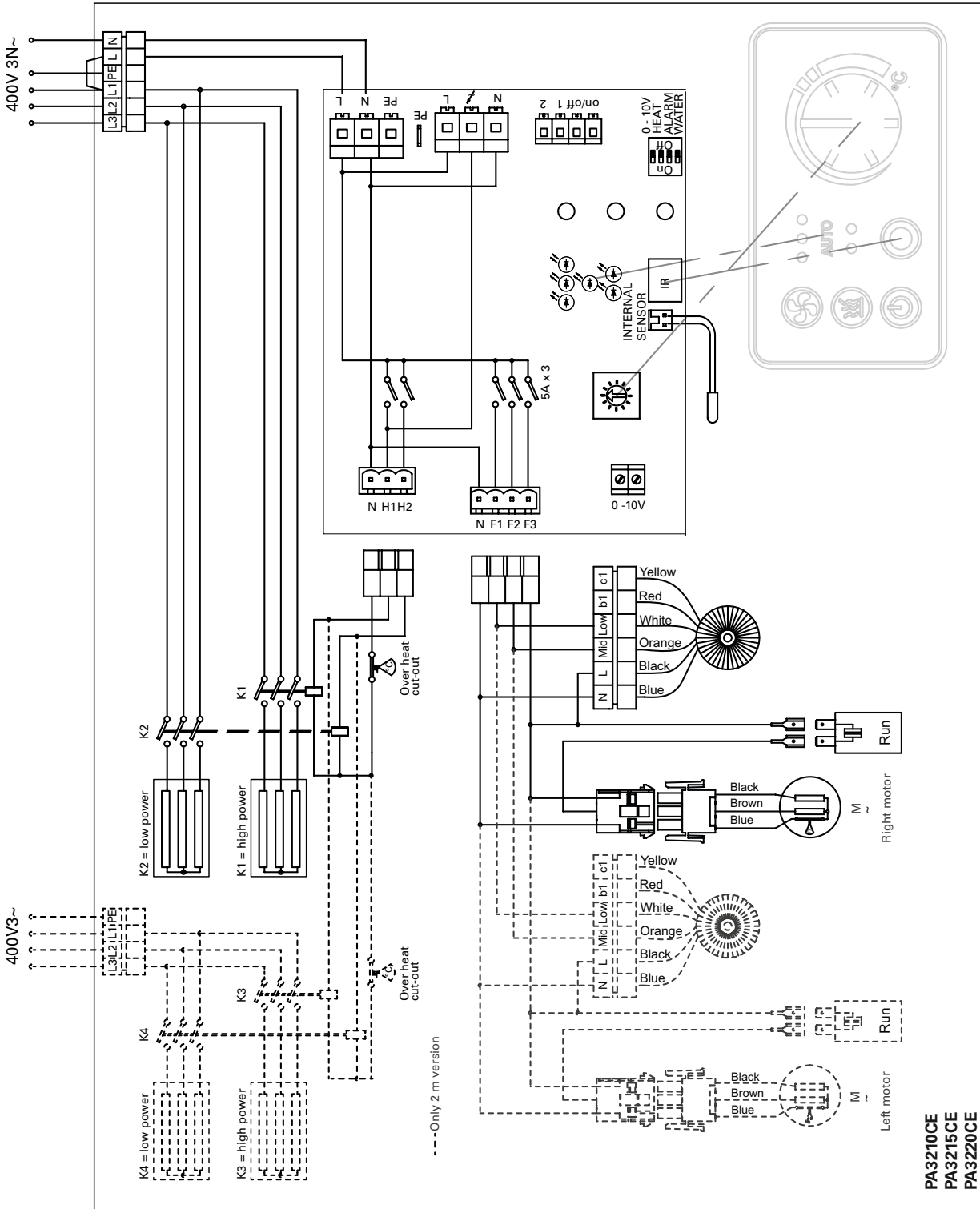

PA3210CE08YD / PA3215CE12YD / PA3220CE16YD 230V3~

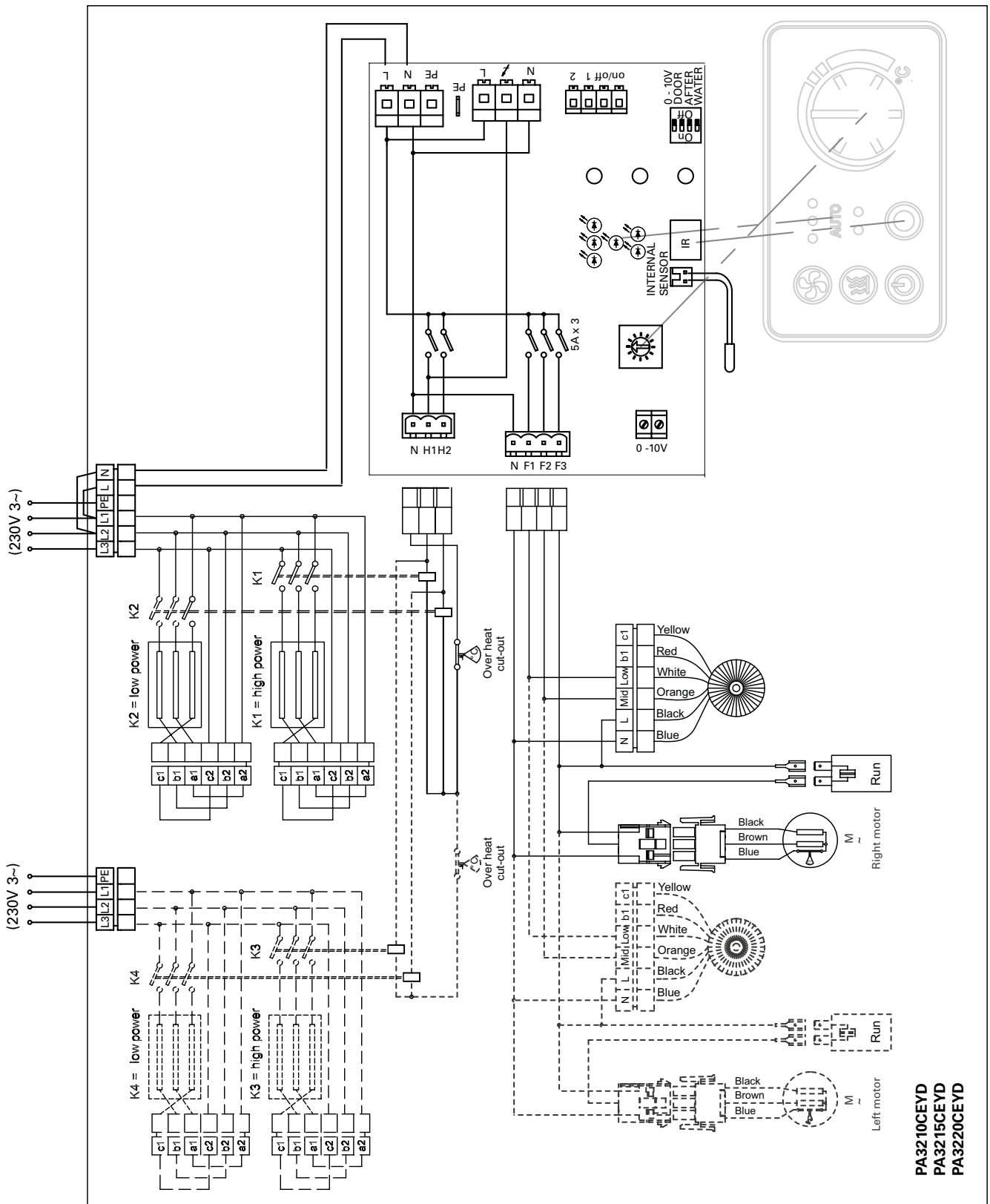

PA3210CEYD  
PA3215CEYD  
PA3220CEYD



For omkobling til 230V3~ gjøres dette bak dekslet på venstre side (aggregater på 2 meter har omkoblingen bak dekslet på midten.)

Connection for 230V3~ is done behind the cover on the left side (on units of 2 metres this is done behind the cover in the middle).

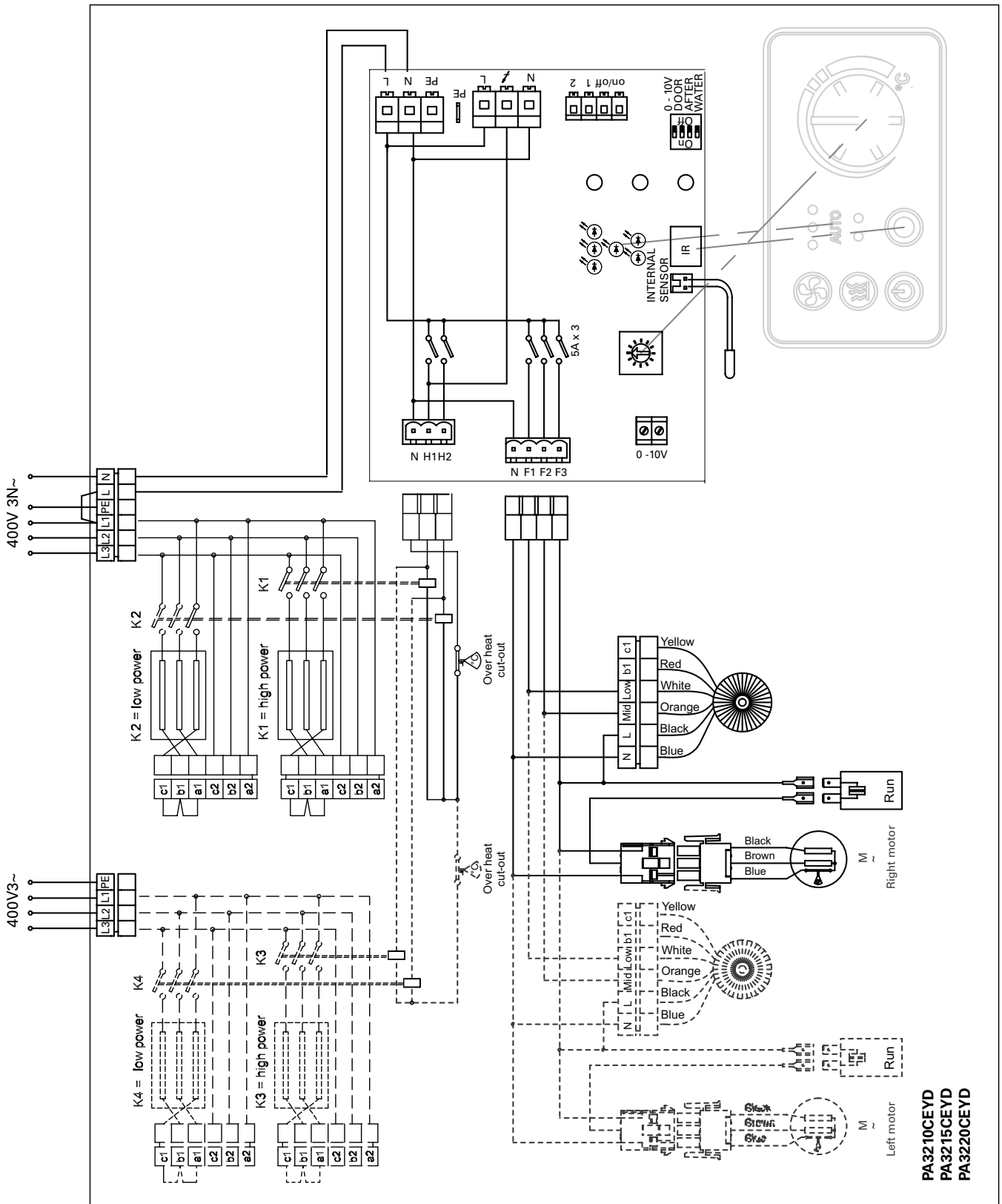

For omkobling til 230V3~ gjøres dette bak dekslet på venstre side (aggregater på 2 meter har omkoblingen bak dekslet på midten.) Se forrige side.

Connection for 230V3~ is done behind the cover on the left side (on units of 2 metres this is done behind the cover in the middle). See previous page.

PA3210CEYD  
PA3215CEYD  
PA3220CEYD

PA3210CW / PA3215CW / PA3220CW

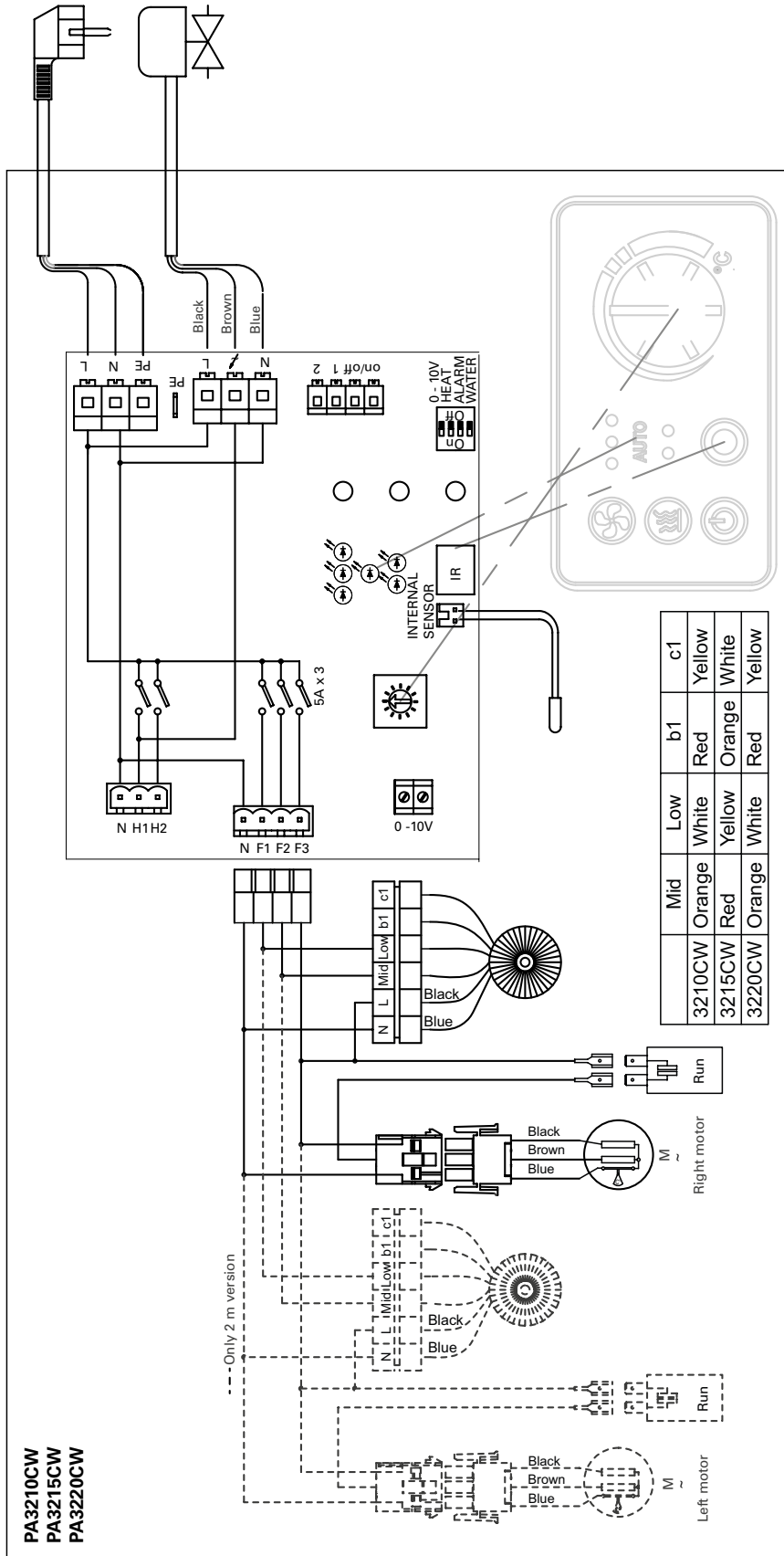

PAMLK

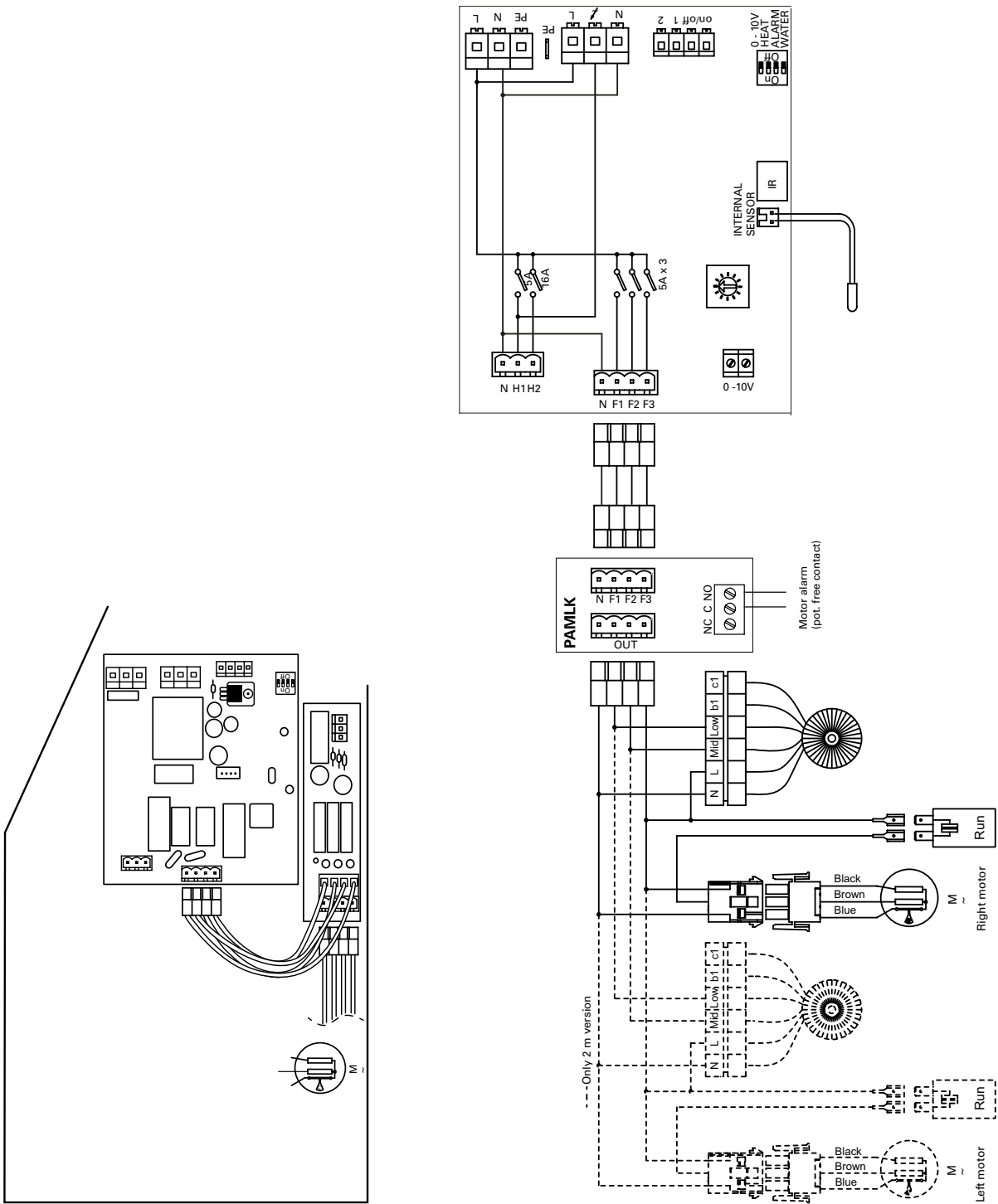

## Installation and operating instructions

### General Instructions

Read these instructions carefully prior to installation and use. Keep this manual for future reference.

*The product may only be used as set out in the assembly and operating instructions. The guarantee is only valid should the product be used in the manner intended and in accordance with the instructions.*

### Application

PA3200C is a compact air curtain with a recommended installation height of 3,2 metres. The air curtain has an integrated control system and can be remotely controlled.

The air curtain is available without heat, with electrical heating and with water heating. Protection class for units with electrical heating: IP20.

Protection class for units without heating and units with water heating: IP21.

### Operation

Air is drawn in at the top of the unit and blown downwards shielding the door opening and minimizing heat loss. To achieve the optimum curtain effect the unit must extend the full width of the door opening.

The grille for directing the outlet air is adjustable and is normally angled outwards to achieve the best protection against incoming air.

The efficiency of the air curtain depends on the air temperature, the pressure differential across the doorway and any wind load.

*NOTE! Negative pressure in the building considerably reduces the efficiency of the air curtain. The ventilation should therefore be balanced.*

### Mounting

The air curtain is installed horizontally with the outlet air grille facing downwards as close to the door as possible. The product must be mounted in such a way as to allow future service and maintenance. Minimum distance from outlet to floor for electrically heated units is 1800 mm. For other minimum distances, see fig. 4.

Brackets and torx bit are enclosed in the gable end packaging upon delivery.

### Mounting with wall brackets (fig. 6)

1. Mount the brackets on the wall, see fig.6A and dimension drawing fig.1. If the wall is uneven the brackets must be compensated for this.
2. Hook on the unit at the lower edge of the brackets. (Fig.6B)
3. Bend the top of the console over the the unit and slide the units screws along the rail into the slots on the consoles. (Fig.6C) When the bracket is bent once, it must be replaced if bent back more than 45 °.
4. Lock the nuts against the brackets. (Fig.6D)

### Horizontal mounting on the ceiling

Threaded rods, hanging brackets and ceiling mounting brackets for ceiling mounting are available as accessories, see accessories pages and separate manuals.

### Electrical installation

The installation, which should be preceded by an isolator switch with a contact separation of at least 3 mm, should only be wired by a competent electrician and in accordance with the latest edition of IEE wiring regulations. The control system is pre-installed in the air curtain.

### Unit without heating

Connected via the built-in control board with 1,5 m cord and plug.

### Unit with water heating

Connected via the built-in control board with 1,5 m cord and plug.

### Unit with electrical heating

The electrical connection is made on the top of the unit. See Fig.2. Control (230V~) and power supply for heat (400V3N~) should be connected to a terminal block in the terminal box. 2-metre and longer units require dual power supplies.

The largest cable diameter for the terminal block is 16 mm<sup>2</sup>. The cable glands used must meet the protection class requirements. In the distribution board, it is to be indicated that "the air curtains can be supplied from more than one connection".

See wiring diagrams.



Type	Output [kW]	Voltage [V]	Minimum area* [mm <sup>2</sup> ]
Control	0	230V~	1,5
PA3210CE08	8	400V3~	2,5
PA3215CE12	12	400V3~	4
PA3220CE16	16	400V3~	6

\*) Dimensioning of external wiring shall comply with applicable regulations and local deviations may occur.

### Start-up (E)

When the unit is used for the first time or after a long period of non-use, smoke or an odour may result from dust or dirt which has collected on the element. This is completely normal and disappears after a short time.

### Connecting the water coil (W)

The installation must be carried out by an authorised installer.

The water coil has copper tubes with aluminium fins and is suitable for connection to a closed water heating system. The heating coil must not be connected to a mains pressure water system or an open water system.

Note that the unit shall be preceded by a regulating valve, see Frico valve kit.

The water coil is connected on top of the unit via steel pipes with DN20 (3/4") terminals, external thread. Flexible hoses are available as accessories, see accessories pages.

The connections to the heating coil must be equipped with shut off valves to allow trouble-free removal. The water coil is equipped with a drain valve. An air valve should be connected at a high point in the pipe system. Air valves are not included.

NOTE: Care must be taken when connecting the pipes. Use a pipe wrench or a similar tool to grip the air curtain connections to prevent straining of the pipes and subsequent water leakage during connection to the water supply pipe-work.

### Adjustment of the air curtain and airflow

The direction and speed of the airflow should be adjusted considering the load on the opening. Pressure forces affect the airstream and force it inwards towards the premises (when the premises are heated and the outdoor air is cold).

The airstream should, therefore, be directed outwards to withstand the load. Generally speaking, the higher the load, the greater the angle required.

### Basic setting fan speed

The fan speed when the door is open is set using the control. Note that the airflow direction and the fan speed may need fine adjustment depending on the loading of the door.

### Filter (W)

The water coil is protected against dirt and blockage by an internal air filter which covers the coil face. In environments where the filter requires frequent cleaning, it is advisable to use an external intake filter (see accessories pages), which provides easier maintenance, since the unit does not need to be opened. When an external filter is used, the internal filter is removed.

### Service, repairs and maintenance

For all service, repair and maintenance first carry out the following:

1. Disconnect the power supply.
2. The front hatch is removed by removing the screws on the top of the unit and then detach the bent edge at the bottom. (Fig.3)
3. After the service, repair and maintenance reattach the front hatch. Place the hatch at the lower edge with the bent edge and fasten on top with screws.

Note that when carrying out work where the end is removed, the outlet grille also detaches.

### Maintenance

#### Unit with water heating

The appliance filter should be cleaned regularly to ensure the air curtain effect and heat emission from the device. How often depends on local circumstances. A clogged filter is not a risk, but the appliance function can fail.

1. Disconnect the power supply.
2. The front hatch is removed by removing the screws on the top of the unit and then detach the bent edge at the bottom. (Fig.3)
3. Remove the filter and vacuum clean or wash it. If the filter is clogged or damaged, it may need to be changed.

#### All units

Since fan motors and other components are maintenance-free, no maintenance other than cleaning is necessary. The level of cleaning can vary depending on local conditions. Undertake cleaning at least twice a year. Inlet and exhaust grilles, impeller and elements can be vacuum cleaned or wiped using a damp cloth. Use a brush when vacuuming to prevent damaging

sensitive parts. Avoid the use of strong alkaline or acidic cleaning agents.

### Overheating

The air curtain unit with electrical heating is equipped with an overheat protection. If it is deployed due to overheating, reset as follows:

1. Disconnect the power supply with the isolator switch.
2. Determine the cause of overheating and rectify the fault.
3. Remove the front hatch.
4. Press the red button located inside the air curtain unit, at the inner gable of the terminal box.
5. Reattach the front hatch and connect the unit again.

All motors are equipped with an integral thermal safety cut-out. This will operate, stopping the air curtain should the motor temperature rise too high. The cut-out will automatically reset when the motor temperature has returned to within the motor's operating limits.

### Temperature control

See control pages.

### Replacing motor or impeller

1. Remove the front.
2. Remove gable end.
3. Remove the screw between motor and fan.
4. Disconnect the cables to the motor.
5. Remove the screws securing the motor and lift it out together with the impeller.
6. Install the new motor and/or the new impeller as above in reverse order.

### Replacing heating elements/heating package (E)

1. Mark and disconnect the cables to the heating elements/package.
2. Remove the mounting screws securing the heating elements/package in the unit and lift the heating elements/package out.
3. Install the new heating elements/package in reverse order to the above.

### Replacing the water coil (W)

1. Shut off the water supply to the unit.
2. Disconnect the connections to the water coil.
3. Detach the plastic ends.
4. Detach the intake grille by drilling out the rivet(s).

5. Remove the mounting screws securing the coil in the unit and lift out.
6. Install the new coil in reverse order to the above.

### Draining the water coil (W)

The drain valve is on the underside of the coil on the connector side. It can be accessed via the front hatch.

### Troubleshooting

*If the fans are not running or do not perform properly, check the following:*

- The functions and settings of the built-in control system.
- That the intake grille/filter is not dirty.

*If there is no heat, check the following:*

- The functions, internal sensor and settings of the built-in control system.

*For units with electrical heating, also check the following:*

- Power supply to electric heater coil; check fuses and circuit-breaker (if any).
- That the overheat protection has not been deployed.

*For units with a water coil, also check the following:*

- That the water coil is vented
- That there is sufficient water flow and pressure.
- That the incoming water is heated adequately.
- That the valves and the actuators are correctly installed and working.

If the fault cannot be rectified, please contact a qualified service technician.

### Residual current circuit breaker (E)

When the installation is protected by means of a residual current circuit breaker, which trips when the appliance is connected, this may be due to moisture in the heating element. When an appliance containing a heater element has not been used for a long period or stored in a damp environment, moisture can enter the element.

This should not be seen as a fault, but is simply rectified by connecting the appliance to the main supply via a socket without a safety cut-out so that the moisture can be eliminated from the element. The drying time can vary

from a few hours to a few days. As a preventive measure, the unit should occasionally be run for a short time when it is not being used for extended periods of time.

### Packaging

Packaging materials are chosen with consideration to the environment and are therefore recyclable.

### Handling of product at end of working life

This product may contain substances necessary for the functionality of the product but potentially dangerous for the environment. The product should not be disposed of mixed with general household waste but delivered to a designated collection point for environmental recycling. Please contact the local authority for further details of your nearest designated collection point.

### Safety

- *For all installations of electrically heated products a residual current circuit breaker 300 mA for fire protection must be used.*
- *Keep the areas around the air intake and exhaust grilles free from possible obstructions!*
- *The unit must not be fully or partially covered as overheating can result in a fire risk!*
- *Lifting equipment must be used to lift the unit.*
- *This appliance can be used by children aged from 8 years and above and persons with reduced physical, sensory or mental capabilities or lack of experience and knowledge if they have been given supervision or instruction concerning use of the appliance in a safe way and understand the hazards involved. Children shall not play with the appliance. Cleaning and user maintenance shall not be made by children without supervision.*
- *Children of less than 3 years should be kept away unless continuously supervised.*
- *Children aged from 3 years and less than 8 years shall only switch on/off the appliance provided that it has been placed or installed in its intended normal operating position and they have been given supervision or instruction concerning use of the appliance in a safe way and understand the hazards involved.*
- *Children aged from 3 years and less than 8 years shall not plug in, regulate and clean the appliance or perform user maintenance.*

**CAUTION — Some parts of this product can become very hot and cause burns. Particular attention has to be given where children and vulnerable people are present.**

**Control**

The air curtain has an integrated control system and can be remotely controlled.

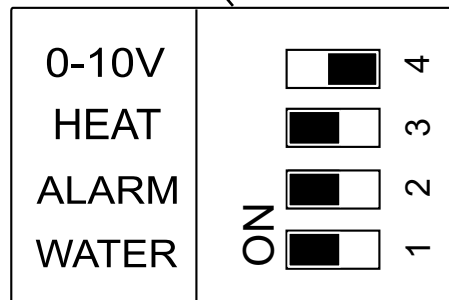
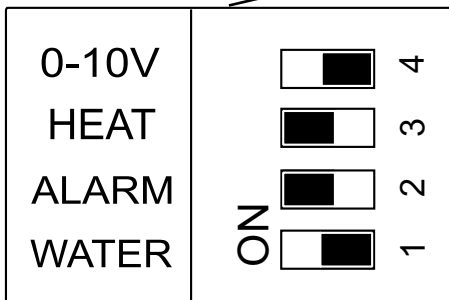
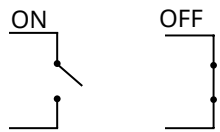
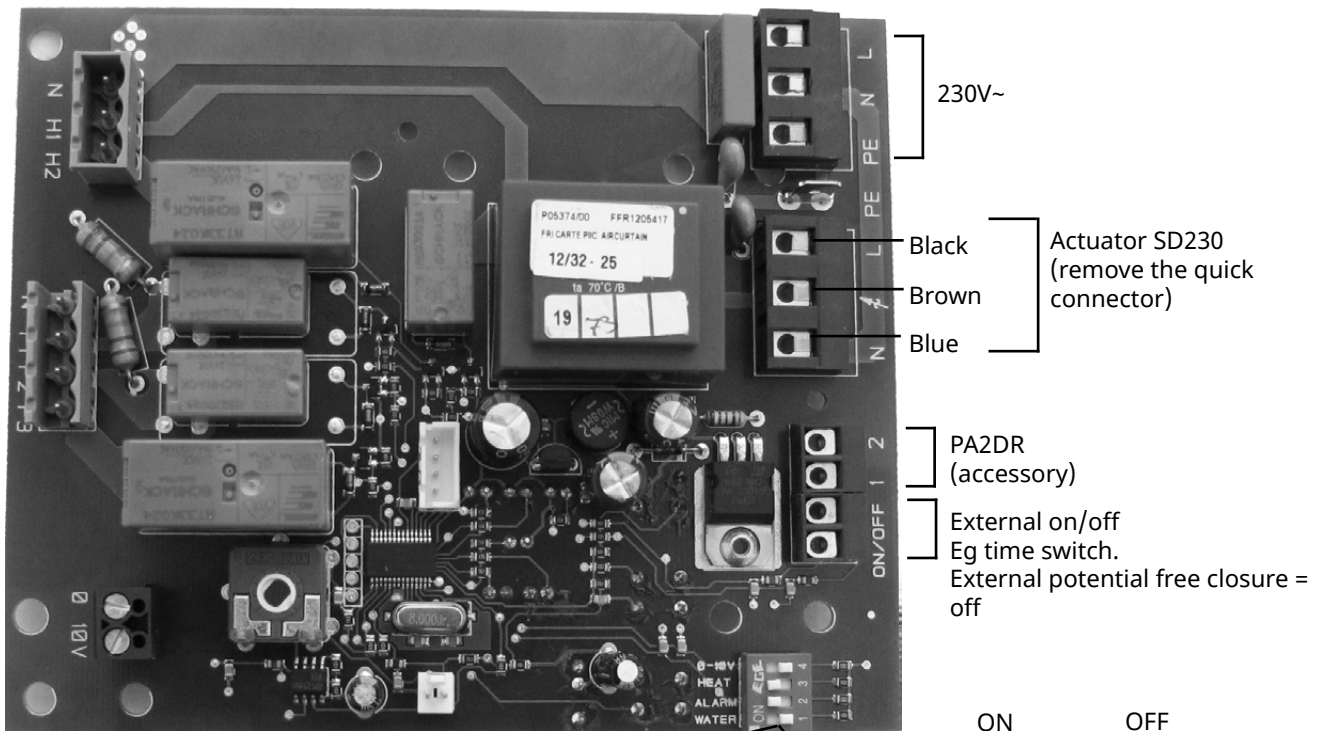
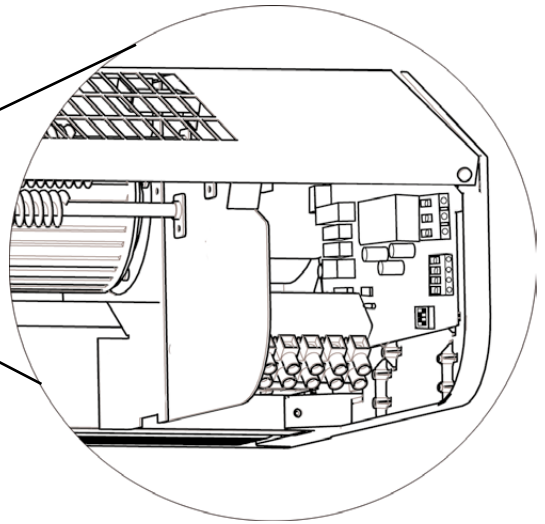
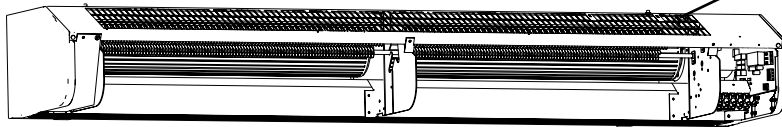

Factory setting dip-switches - Unit without heating or with electrical heating

Factory setting dip-switches - Unit with water heating

Dip-switch 3 is used for PA2DR (optional).

Dip-switch 3 is used for PA2DR (optional).

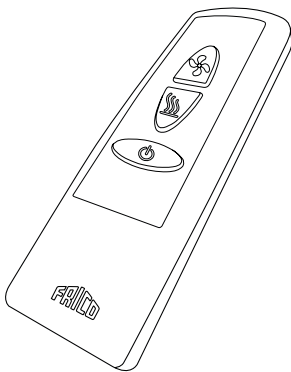
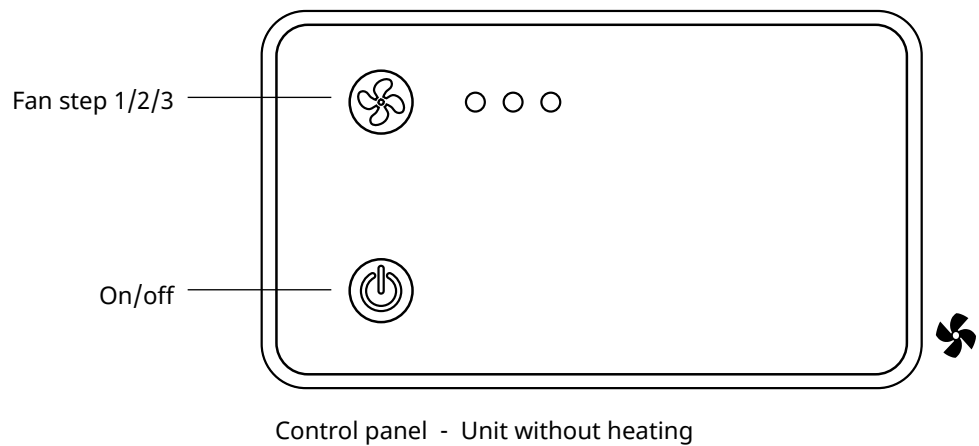
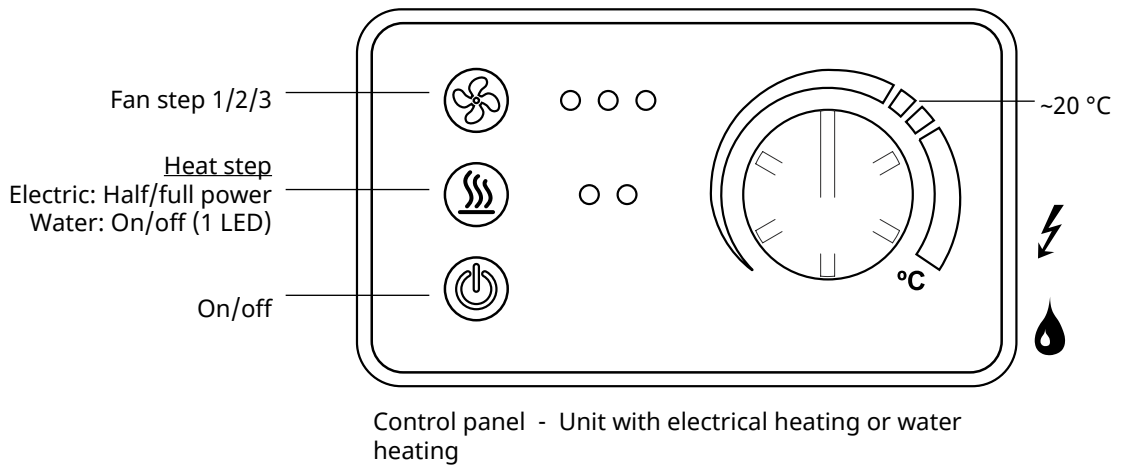

Remote control - on/off, fan steps and heating steps

**Functional test**

Functional test is started using the remote control.

Push



and



in 5 seconds

Fan and heatings steps are tested in 10-second intervals which is indicated by lighted LEDs. When the test is completed, all LEDs will flash for 30 seconds.

**Temperature control**

If the temperature exceeds 50 °C, the fan runs at full speed for 2 minutes to vent out the heat, if the temperature rises above 50 °C again during the following 5 minutes overheating alarm is deployed. The red LEDs flash and all the buttons are locked.

1. Disconnect the power supply with the isolator switch.
2. Determine the cause of overheating and rectify the fault.
3. Reconnect the unit.





**Main office**

Frico AB  
Industrivägen 41  
SE-433 61 Sävedalen  
Sweden

Tel: +46 31 336 86 00  
mailbox@frico.se  
www.frico.net

**For latest updated information and information  
about your local contact: [www.frico.net](http://www.frico.net)**