

Original instructions

PAEC3200

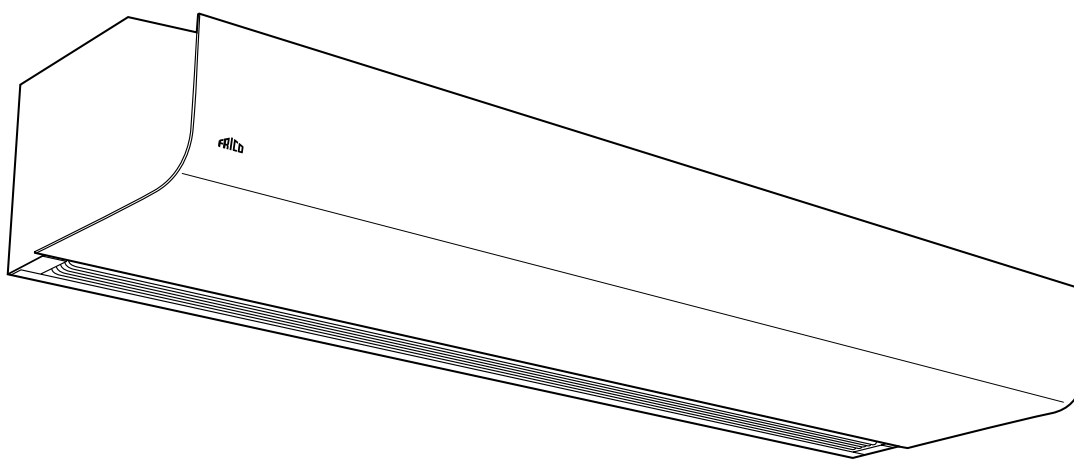

SE ... 10

EN ... 13

NO ... 15

DE ... 18

ES ... 21

FR ... 24

IT ... 27

NL ... 30

PL ... 33

RU ... 36

DK ... 40

FI ... 43

- EN The introduction pages consist mainly of pictures. For translation of the English texts used, see the respective language pages.
- SE Introduktionssidorna består huvudsakligen av bilder. För översättning av de engelska texter som används, se respektive språksidor.
- NO Introduksjonssidene består hovedsakelig av bilder. For oversettelse av de engelske tekstene, se de respektive språksidene.
- FR Les pages de présentation contiennent principalement des images. Pour la traduction des textes en anglais, consultez la page correspondante à la langue souhaitée.
- DE Die Einleitungsseiten bestehen hauptsächlich aus Bildern. Für die Übersetzung der verwendeten Texte in englischer Sprache, siehe die entsprechenden Sprachseiten.
- ES Las páginas introductorias contienen básicamente imágenes. Consulte la traducción de los textos en inglés que las acompañan en las páginas del idioma correspondiente.
- NL De inleidende pagina's bevatten hoofdzakelijk afbeeldingen. Voor een vertaling van de gebruikte Engelse teksten, zie de pagina's van de resp. taal.
- IT Le pagine introduttive contengono prevalentemente immagini. Per le traduzioni dei testi scritti in inglese, vedere le pagine nelle diverse lingue.
- PL Początkowe strony zawierają głównie rysunki. Tłumaczenie wykorzystanych tekstów angielskich znajduje się na odpowiednich stronach językowych.
- RU Страницы в начале Инструкции состоят в основном из рисунков, схем и таблиц. Перевод встречающегося там текста приведен в разделе RU.
- FI Esittelysivut koostuvat lähinnä kuvista. Suvuilla olevien enlanninkielisten sanojen käännökset löytyvät ko. kielisivuilta.
- DK Introduktionssiderne består hovedsageligt af billeder. For oversættelse af de engelske tekster, se siderne for de respektive sprog.

PAEC3200

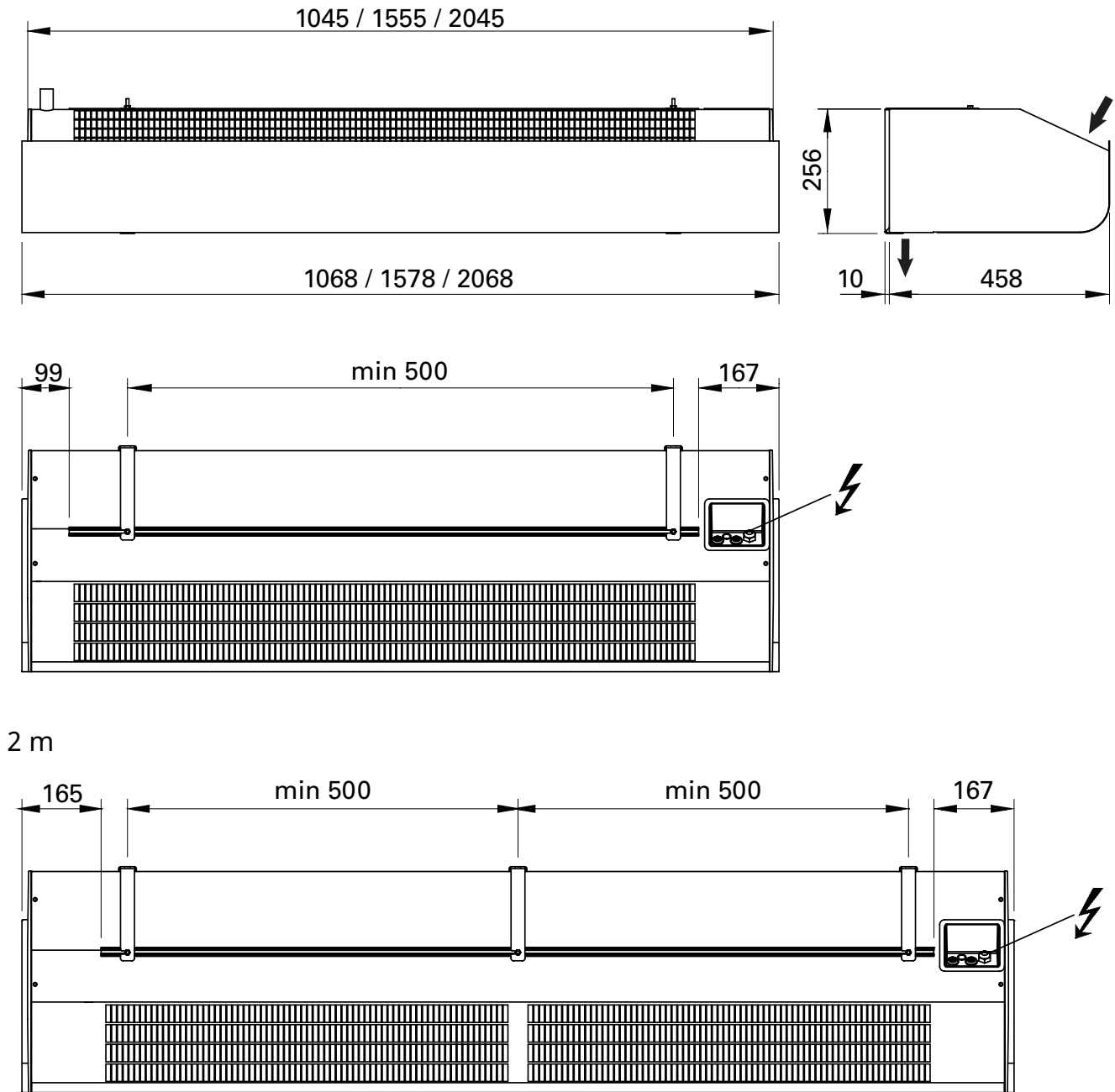

Fig. 1

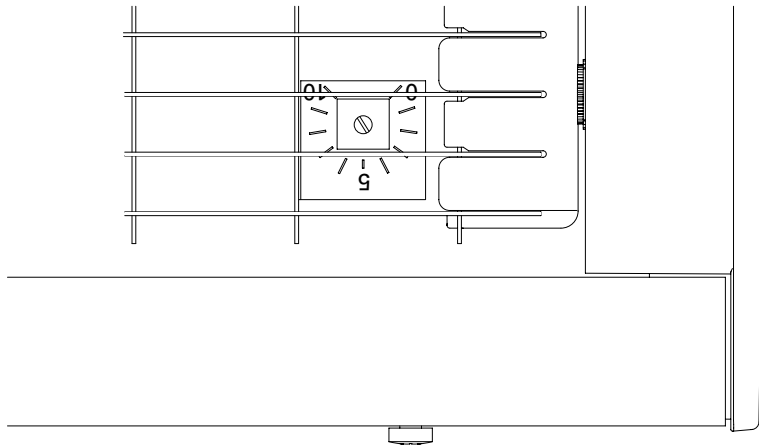

Fig. 2: Stepless regulation of airflow. Internal potentiometer (accessible through the outlet grille).

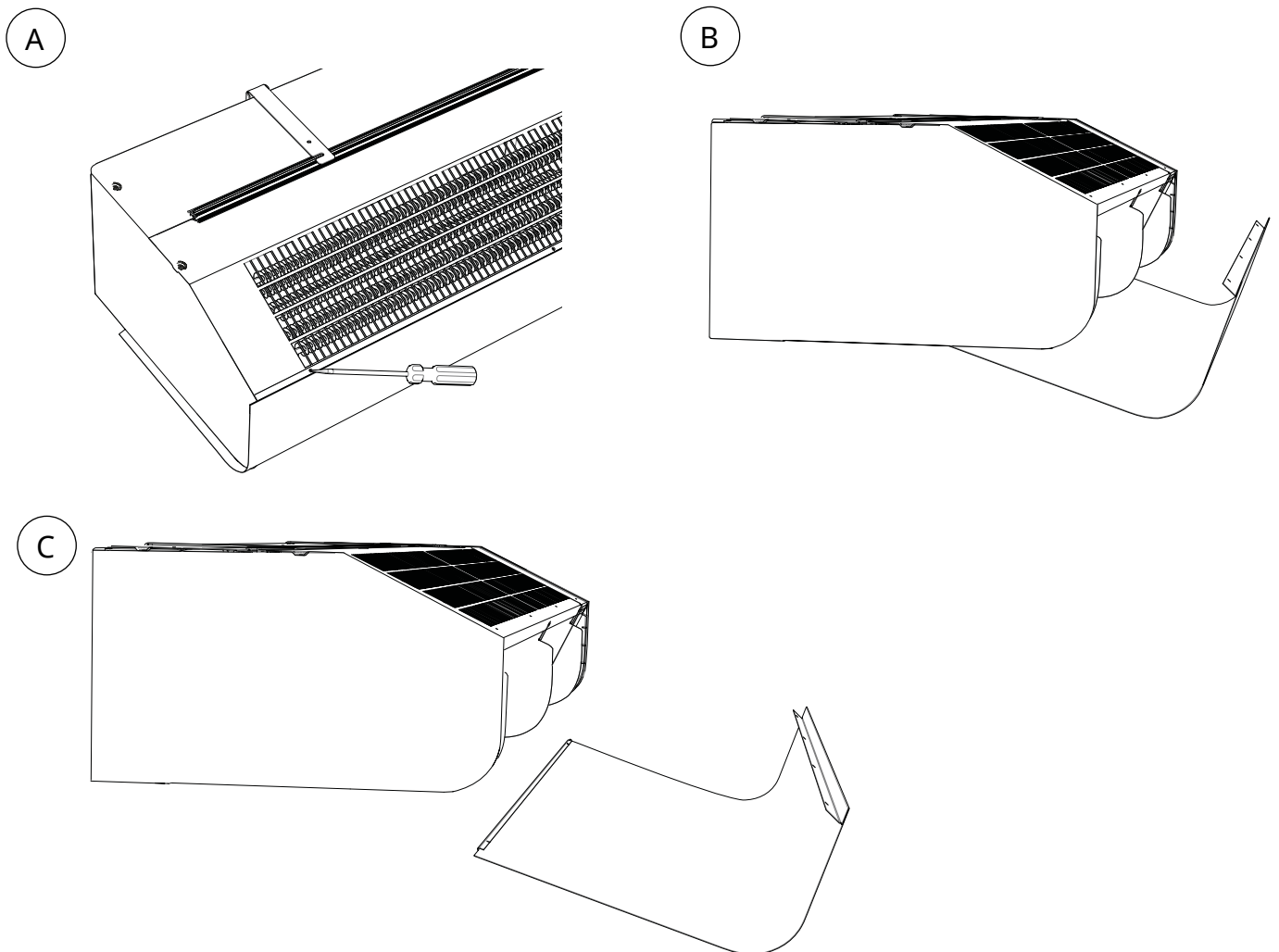

Fig.3: Open the unit.

Mounting with wall brackets

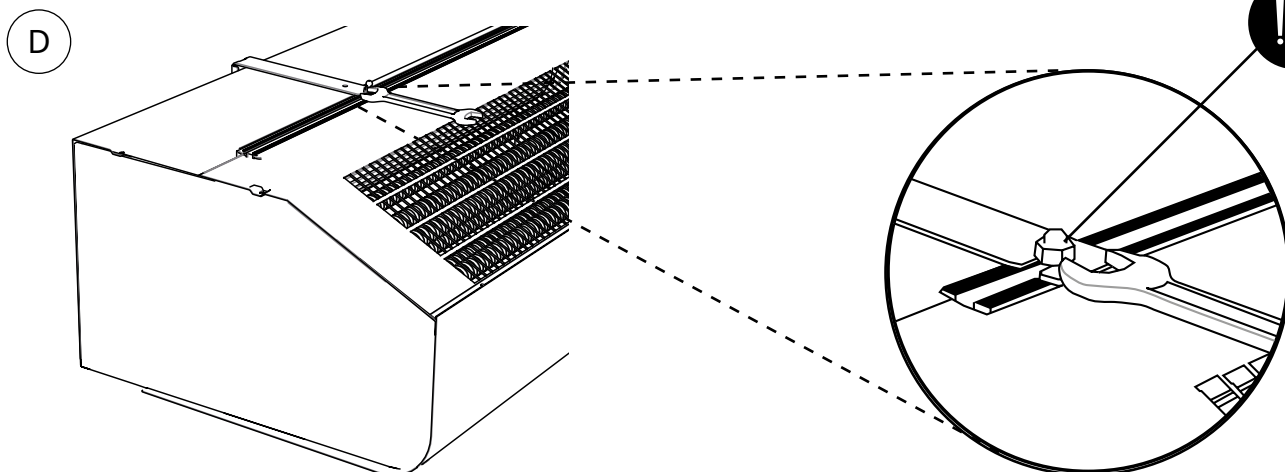
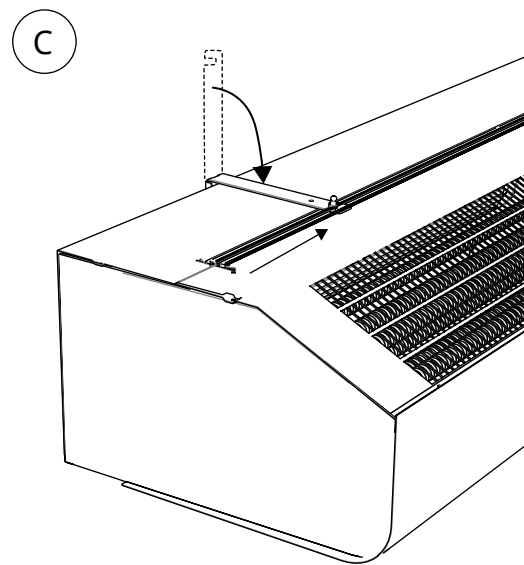
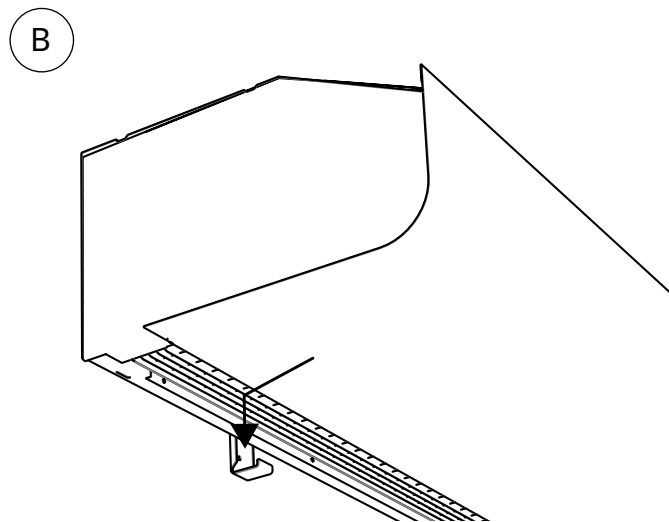
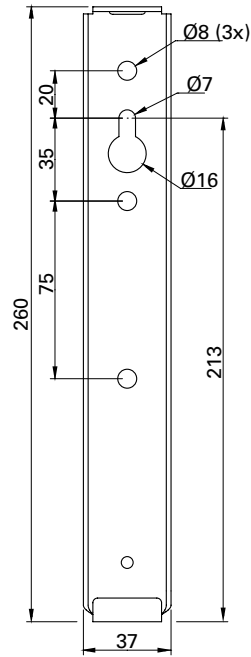
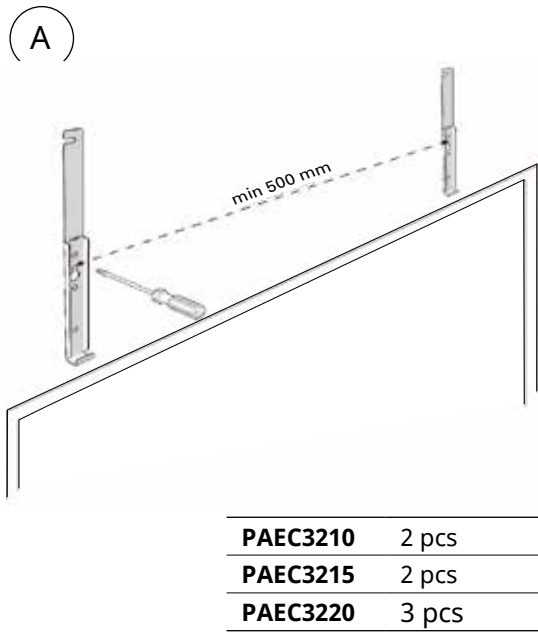

Fig. 4: Mounting with wall brackets

Accessories



PA34TR



PA2P

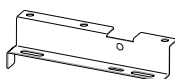

PA3PF

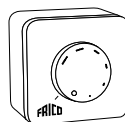

PAMP10



FCDC



AGB304

Item number	Type		Consists of	Dimension
18056	PA34TR15*	PAEC3210, PAEC3215	4 pcs	1 m
18057	PA34TR20*	PAEC3220	6 pcs	1 m
19568	PA2P15*	PAEC3210, PAEC3215	2 pcs	1 m
19569	PA2P20*	PAEC3220	3 pcs	1 m
25256	PA3PF15*	PAEC3210, PAEC3215	4 pcs	
25257	PA3PF20*	PAEC3220	6 pcs	
87675	PAMP10	PAEC3200	1 pc	82x82x65 mm
17495	FCDC	PAEC3200	1 pc	
10016	AGB304	PAEC2500	1 pc	

*) See separate manual.

PAEC3200

Stepless airflow control

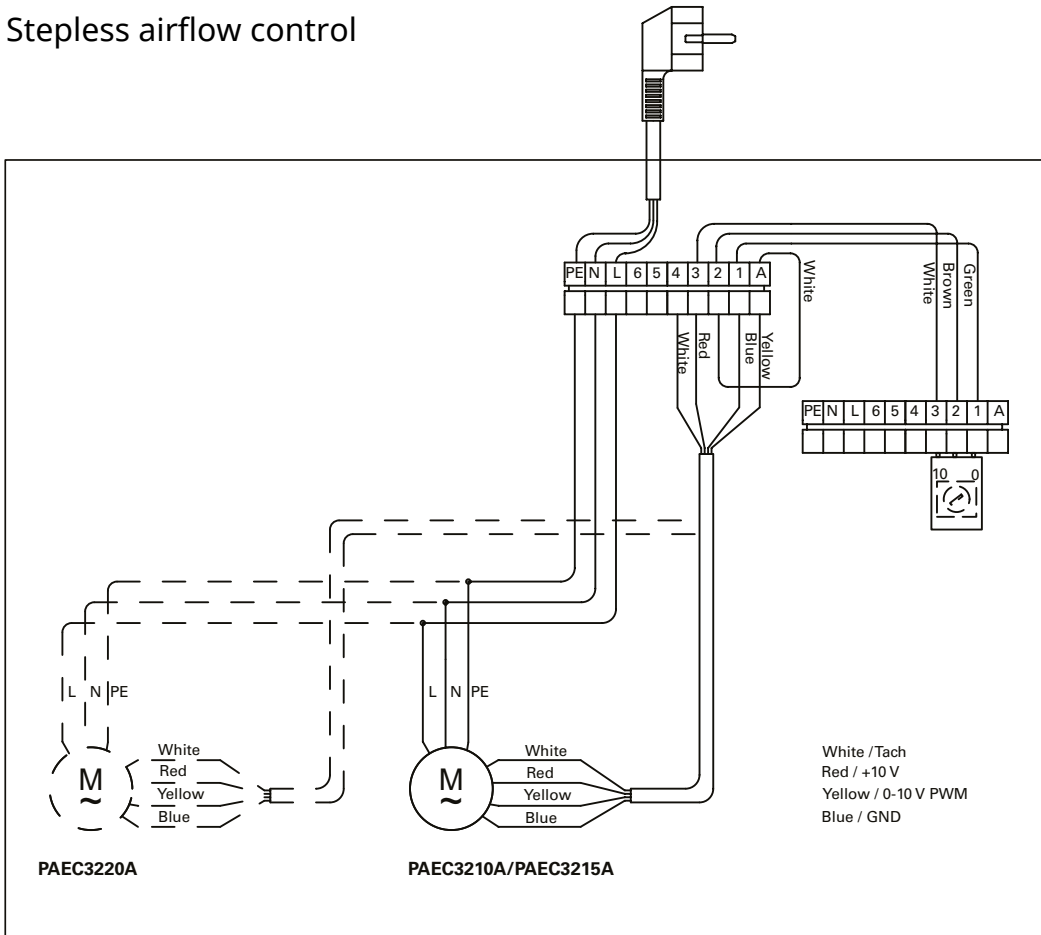

Stepless airflow control with external potentiometer

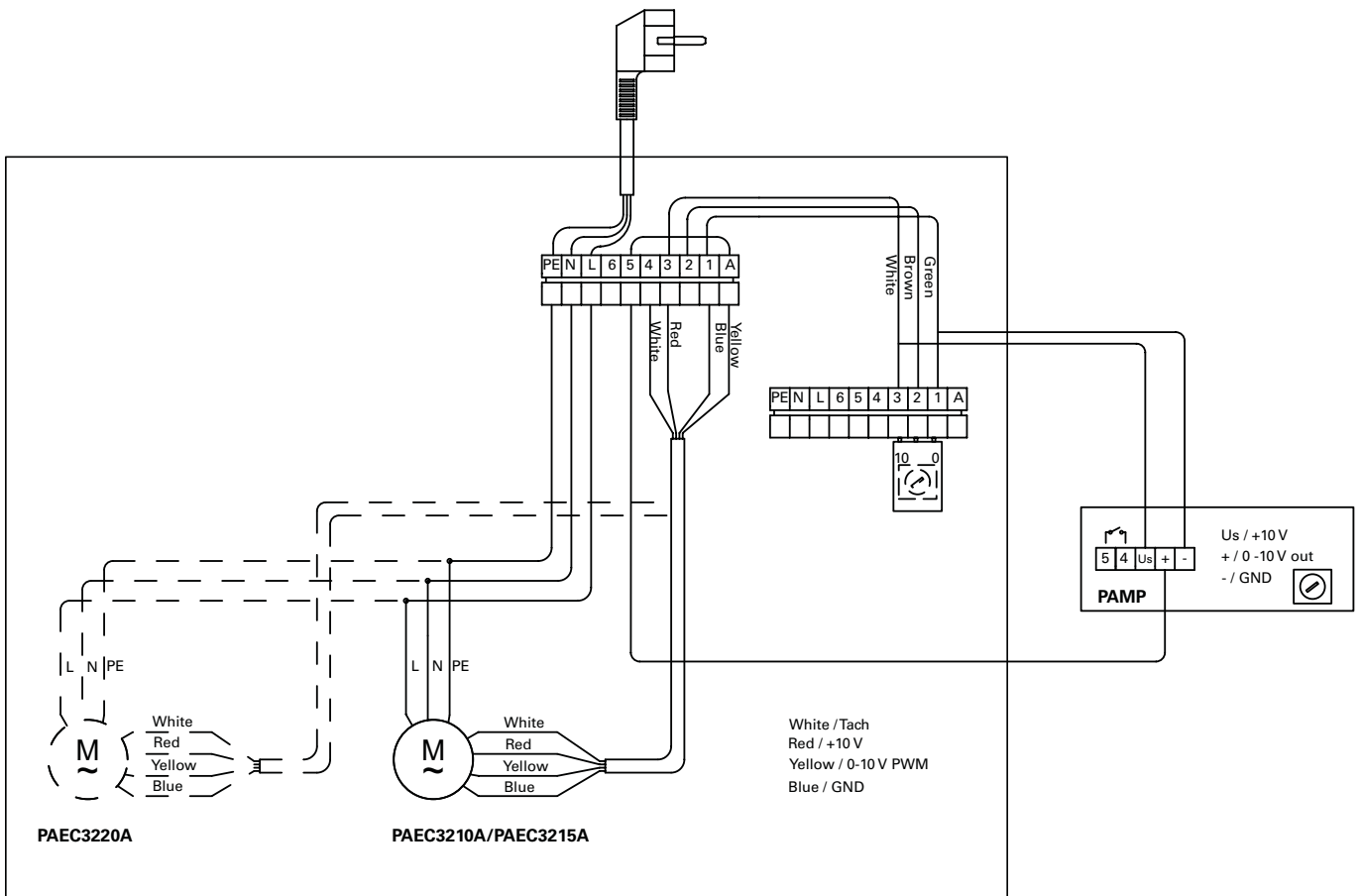

PAEC3200

Stepless airflow control with door contact / position limit switch

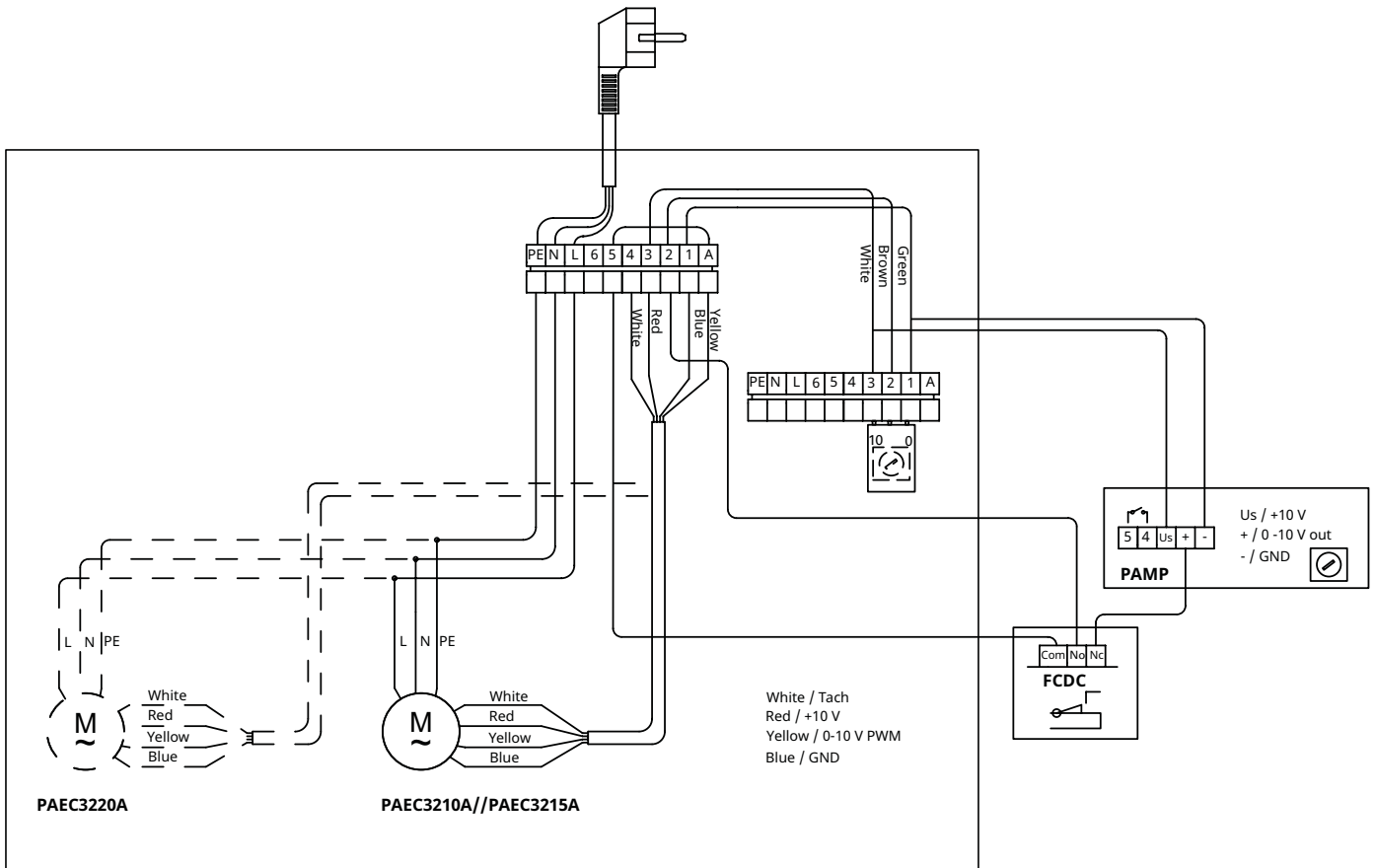

✦ Ambient, no heat - PAEC3200 A (IP44)

Item number	Type	Output [kW]	Airflow [m ³ /h]	Sound power* ¹ [dB(A)]	Sound pressure* ² [dB(A)]	Voltage motor [V]	Amperage motor* ³ [A]	Length [mm]	Weight [kg]
77517	PAEC3210A	0	1950	74	40/58	230V~	0,19/1,15	1068	22
77518	PAEC3215A	0	2700	74	39/58	230V~	0,20/1,20	1578	32
77519	PAEC3220A	0	3800	77	43/61	230V~	0,36/2,30	2068	42

*¹) Sound power (L_{WA}) measurements according to ISO 27327-2: 2014, Installation type E.

*²) Sound pressure (L_{pA}). Conditions: Distance to the unit 5 metres. Directional factor: 2. Equivalent absorption area: 200 m². At 50% and 100% airflow.

*³) Applicable at 50% and 100% airflow.



Installation and operating instructions

General Instructions

Read these instructions carefully prior to installation and use. Keep this manual for future reference.

The product may only be used as set out in the assembly and operating instructions. The guarantee is only valid should the product be used in the manner intended and in accordance with the instructions.

Application

PAEC3200 is an air curtain for cold storage and freezer rooms as well as entrances. Installation height for cold storage is up to 5 metres. Recommended installation height for entrances is 3,2 metres. The air curtain has stepless control using an internal or external potentiometer (accessory). Protection class: IP44.

Operation

Air is drawn in at the top of the unit and blown downwards shielding the door opening and minimizing heat loss. To achieve the optimum curtain effect the unit must extend the full width of the door opening.

The grille for directing the outlet air is adjustable and is normally angled outwards to achieve the best protection against incoming air.

The efficiency of the air curtain depends on the air temperature, the pressure differential across the doorway and any wind load.

NOTE! Negative pressure in the building considerably reduces the efficiency of the air curtain. The ventilation should therefore be balanced.

Mounting

The air curtain unit is installed horizontally with the outlet air grille facing downwards as close to the door as possible. When the unit is used to protect cold storage or freezer rooms, it must be mounted on the outside of the conditioned space.

Brackets and torx bit are enclosed in the gable end packaging upon delivery.

Mounting with wall brackets (fig. 4)

1. Mount the brackets on the wall, see fig.4A and dimension drawing fig.1. If the wall is uneven the brackets must be compensated for this.
2. Hook on the unit at the lower edge of the brackets. (Fig.4B)

3. Bend the top of the console over the the unit and slide the units screws along the rail into the slots on the consoles. (Fig.4C) When the bracket is bent once, it must be replaced if bent back more than 45 °.

4. Lock the nuts against the brackets. (Fig.4D)

Horizontal mounting on the ceiling

Threaded rods, hanging brackets and ceiling mounting brackets for ceiling mounting are available as accessories, see accessories pages and separate manuals.

Connection

The unit is connected with a 1.5m cord and plug.

Control options

Stepless airflow control

The airflow is set manually on the internal potentiometer 0-10V, which is located inside the outlet grille.

Stepless airflow control with external potentiometer

The airflow is set manually on an external potentiometer 0-10V.

Stepless airflow control with door contact/position limit switch

When the door is closed the fan runs at low speed, set on the internal potentiometer 0-10V, which is located inside the outlet grille. When the door opens, the fan runs at high speed, set on an external potentiometer. This control option gives low response time and the best protection.

BMS control

The air curtain can also be controlled via BMS (0-10V).

See Figure 2 and Accessories pages.

Adjustment of the air curtain and airflow

The direction and speed of the airflow should be adjusted considering the load on the opening. Pressure forces affect the airstream and force it inwards towards the premises (when the premises are heated and the outdoor air is cold).

The airstream should, therefore, be directed outwards to withstand the load. Generally

speaking, the higher the load, the greater the angle required.

Basic setting fan speed

The fan speed when the door is open is set using the control. Note that the airflow direction and the fan speed may need fine adjustment depending on the loading of the door.

Service, repairs and maintenance

For all service, repair and maintenance first carry out the following:

1. Disconnect the power supply.
2. The front hatch is removed by removing the screws on the top of the unit and then detach the bent edge at the bottom. (Fig.3)
3. After the service, repair and maintenance reattach the front hatch. Place the hatch at the lower edge with the bent edge and fasten on top with screws.

Note that when carrying out work where the end is removed, the outlet grille also detaches.

Maintenance

Since fan motors and other components are maintenance-free, no maintenance other than cleaning is necessary. The level of cleaning can vary depending on local conditions. Undertake cleaning at least twice a year. Inlet and exhaust grilles, impeller and elements can be vacuum cleaned or wiped using a damp cloth. Use a brush when vacuuming to prevent damaging sensitive parts. Avoid the use of strong alkaline or acidic cleaning agents.

Overheating

The motors have built-in protection against overheating and will automatically regulate their speed at high temperatures.

Replacing motor or impeller

1. Remove the front.
2. Remove gable end.
3. Remove the screw between motor and fan.
4. Disconnect the cables to the motor.
5. Remove the screws securing the motor and lift it out together with the impeller.
6. Install the new motor and/or the new impeller as above in reverse order.

Troubleshooting

If the fans are not running or do not perform properly, check the following:

- The functions and settings of the built-in

control system.

- That the intake grille/filter is not dirty.

If the fault cannot be rectified, please contact a qualified service technician.

Packaging

Packaging materials are chosen with consideration to the environment and are therefore recyclable.

Handling of product at end of working life

This product may contain substances necessary for the functionality of the product but potentially dangerous for the environment. The product should not be disposed of mixed with general household waste but delivered to a designated collection point for environmental recycling. Please contact the local authority for further details of your nearest designated collection point.

Safety

- *Keep the areas around the air intake and exhaust grilles free from possible obstructions!*
- *Lifting equipment must be used to lift the unit.*
- *This appliance can be used by children aged from 8 years and above and persons with reduced physical, sensory or mental capabilities or lack of experience and knowledge if they have been given supervision or instruction concerning use of the appliance in a safe way and understand the hazards involved. Children shall not play with the appliance. Cleaning and user maintenance shall not be made by children without supervision.*
- *Children of less than 3 years should be kept away unless continuously supervised.*
- *Children aged from 3 years and less than 8 years shall only switch on/off the appliance provided that it has been placed or installed in its intended normal operating position and they have been given supervision or instruction concerning use of the appliance in a safe way and understand the hazards involved.*
- *Children aged from 3 years and less than 8 years shall not plug in, regulate and clean the appliance or perform user maintenance.*

CAUTION — Some parts of this product can become very hot and cause burns. Particular attention has to be given where children and vulnerable people are present.



Main office

Frico AB

Industrivägen 41

SE-433 61 Sävedalen

Sweden

Tel: +46 31 336 86 00

mailbox@frico.se

www.frico.net

**For latest updated information and information
about your local contact: www.frico.net**