



## VTTV/VTTR/VTTB

2-, 3-way and 3-way (bypass) zone valves

Valves for control of heating and cooling in fan-coil or chilled beams applications. The valves are intended to be used together with the thermal RTAN and RTAOM actuators. They are available as 2- and 3-way versions, as well as bypass versions. The valves have linear flow characteristics.

- ✓ Size DN15...DN20
- ✓ Kvs values 0.25...6.0
- ✓ Media temperature 2...95°C
- ✓ Pressure rating PN16
- ✓ No leakage

### Function

The 2-way valve is closed when the stem is in its highest position and completely open when the stem is in its lowest position.

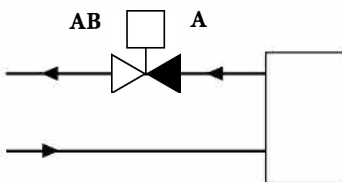

2-way valve

The 3-way valve is closed between port A and port AB (the ports opposite to one another) when the stem is in its highest position. In this position, the valve is also open between the bottom port B and the common supply port AB. When the stem is in its lowest position, the 3-way valve is completely open between port A and port AB and consequently closed between the bottom port B and the common port AB.

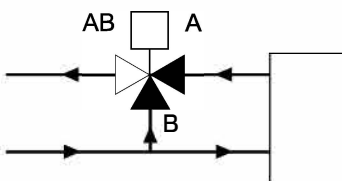

3-way valve

The bypass valve operates in the same way as the 3-way valve, but the connection to bottom port B has a different design.

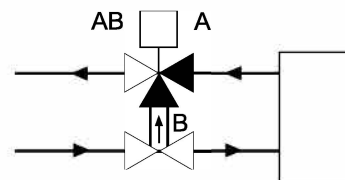

3-way bypass valve

### No leakage in closed position

The valve has O-ring sealing between plug and seat, which makes it completely tight in closed position. This makes the valve very energy-efficient.

## Installation

The 3-way and bypass valves can be used either as mixing valves or as diverting valves.

As mixing valves (2 inlets, 1 outlet), they must be mounted in the mixing point, according to the flow direction marks on the valve.

As diverting valves (1 inlet, 2 outlets), the maximum differential pressure allowed is one third of the normal value (see schedule).

- Before installation of the control valve, ensure that the pipe is clean. Make sure that pipe scale, metal chips, welding slag and other foreign materials are removed.
- For maximum efficiency and minimum wear, install the valve in a vertical position with the stem pointing upward. If the valve is mounted with the actuator on the side, more wear is caused to the valve packing box. The valve should never be mounted at an angle of more than 90°. At high media temperatures, the valve is to be mounted with the spindle to the side in order to minimise heating of the valve actuator.

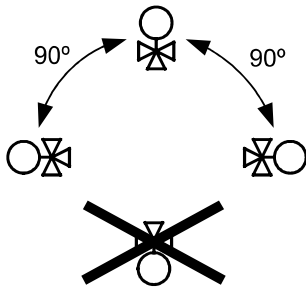

- Install the valve according to the fluid direction arrow shown on the valve.
- Make sure there is ample space above the valve to facilitate easy removal of the valve actuator.
- Fit a strainer/filter upstream of the valve to prolong the equipment's life span.
- A water quality according to VDI 2035 is recommended.

## Technical data

<b>Application</b>	Heating systems, cooling systems, fan-coil units, ventilation systems
<b>Pressure rating</b>	PN16
<b>Connection</b>	BSP externally threaded according to ISO 228/1
<b>Flow characteristics</b>	Linear
<b>Max. leakage</b>	0 % of the kvs value
<b>Media</b>	Hot water, cold water, glycol-mixed water (max. 40 % glycol)
<b>Media temperature</b>	+2...+95 °C
<b>Stroke</b>	2.5 mm
<b>Adapter</b>	Included for RTAOM...actuators. No adapter is needed for RTAN... actuators.

## Material

<b>Body</b>	Brass CW614N
<b>Plug</b>	PA + GF
<b>Stem</b>	PA + GF
<b>Spring</b>	Stainless steel
<b>Packing box</b>	PPO + GP
<b>O-rings</b>	FKM

## 2-way valves

Article	Nominal diameter	Kvs, A-AB	Kvs, B-AB	Max. diff. pressure	Actuator
VTTV15-0,25	DN15 (G 1/2)	0.25	-	250 kPa	RTAN, RTAOM100
VTTV15-0,4	DN15 (G 1/2)	0.4	-	250 kPa	RTAN, RTAOM100
VTTV15-0,6	DN15 (G 1/2)	0.6	-	250 kPa	RTAN, RTAOM100
VTTV15-1,0	DN15 (G 1/2)	1.0	-	250 kPa	RTAN, RTAOM100
VTTV15-1,6	DN15 (G 1/2)	1.6	-	250 kPa	RTAN, RTAOM100
VTTV20-2,5	DN20 (G 3/4)	2.5	-	250 kPa	RTAN, RTAOM100
VTTV20-4,0	DN20 (G 3/4)	4.0	-	80 kPa	RTAN140, RTAOM125
VTTV20-6,0	DN20 (G 3/4)	6.0	-	80 kPa	RTAN140, RTAOM125

## 3-way valves

Article	Nominal diameter	Kvs, A-AB	Kvs, B-AB	Max. diff. pressure	Actuator
VTTR15-0,25	DN15 (G 1/2)	0.25	0.25	250 kPa	RTAN, RTAOM100
VTTR15-0,4	DN15 (G 1/2)	0.4	0.4	250 kPa	RTAN, RTAOM100
VTTR15-0,6	DN15 (G 1/2)	0.6	0.6	250 kPa	RTAN, RTAOM100
VTTR15-1,0	DN15 (G 1/2)	1.0	0.8	250 kPa	RTAN, RTAOM100
VTTR15-1,6	DN15 (G 1/2)	1.6	1.0	250 kPa	RTAN, RTAOM100
VTTR20-2,5	DN20 (G 3/4)	2.5	1.6	250 kPa	RTAN, RTAOM100
VTTR20-4,0	DN20 (G 3/4)	4.0	2.5	80 kPa	RTAN140, RTAOM125
VTTR20-6,0	DN20 (G 3/4)	6.0	4.0	80 kPa	RTAN140, RTAOM125

## 3-way valves with bypass

Article	Nominal diameter	Kvs, A-AB	Kvs, B-AB	Max. diff. pressure	Actuator
VTTB15-0,25	DN15 (G 1/2)	0.25	0.25	250 kPa	RTAN, RTAOM100
VTTB15-0,4	DN15 (G 1/2)	0.4	0.4	250 kPa	RTAN, RTAOM100
VTTB15-0,6	DN15 (G 1/2)	0.6	0.6	250 kPa	RTAN, RTAOM100
VTTB15-1,0	DN15 (G 1/2)	1.0	0.8	250 kPa	RTAN, RTAOM100
VTTB15-1,6	DN15 (G 1/2)	1.6	1.0	250 kPa	RTAN, RTAOM100
VTTB20-2,5	DN20 (G 3/4)	2.5	1.6	250 kPa	RTAN, RTAOM100
VTTB20-4,0	DN20 (G 3/4)	4.0	2.5	80 kPa	RTAN140, RTAOM125
VTTB20-6,0	DN20 (G 3/4)	6.0	4.0	80 kPa	RTAN140, RTAOM125

## Valve connections for copper tubing

Article	Description	Connection	Valve
1885136	Nut and olive	1/2", K12	CTV10, ZTV15, ZTR15, VTTV15, VTTR15, VTTB
1886274	Nut and olive	3/4", K15	CTV15, ZTV20 (kvs 2.0-2.5), ZTR (kvs 2.0-2.5), VTTV20 (kvs 2.5), VTTR20 (kvs 2.5), VTTB20 (kvs 2.5)
1884709	Nut and olive	3/4", K18	CTV15, ZTV20, ZTR20, VTTV20, VTTR20, VTTB20



188...

## Steel pipe connection for VTTV/VTTR/VTTB and ZTV/ZTR valves

Article	Description	Connection	Valve
OVC-Z15	Pipe connection	1/2" (DN15)	VTTV/VTTR/VTTB, ZTV/ZTR (DN15)
OVC-Z20	Pipe connection	3/4" (DN20)	VTTV/VTTR/VTTB, ZTV/ZTR (DN20)



OVC-Z...

## Suitable valve actuators

Article	Supply voltage	Control signal
RTAOM100-24	24 V AC/DC	On/off, NO
RTAOM100-24A	24 V AC	0...10 V DC, NO
RTAOM100-230	230 V AC	On/off, NO
RTAOM125-24	24 V AC/DC	On/off, NO
RTAOM125-230	230 V AC	On/off, NO
RTAN-24	24 V AC ± 10 %, 50/60 Hz	On/Off
RTAN-230	230 V AC ± 10 %, 50/60 Hz	On/Off
RTAN-24A	24 V AC ± 10 %, 50/60 Hz	0...10 V DC
RTAN140-24	24 V AC ± 10 %, 50/60 Hz	On/Off
RTAN140-230	230 V AC ± 10 %, 50/60 Hz	On/Off
RTAN140-24A	24 V AC ± 10 %, 50/60 Hz	0...10 V DC

VTTV/VTTR/VTTB valve + RTAOM or RTAN actuator = Valve closed against port A when actuator has no voltage applied

## Dimensions

Measurements in mm unless otherwise specified.

### 2-way valves

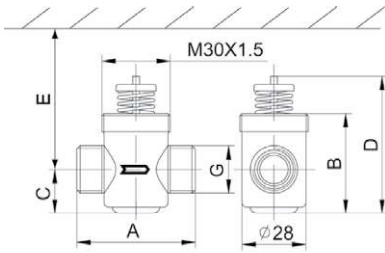

Model	G	A	B	C	D	E	Weight (g)
VTTV15	1/2"	52	46	20	62	≥ 130	110
VTTV20-2,5	3/4"	56	46	22	62	≥ 130	120
VTTV20-4,0/6,0	3/4"	78	59	35	75	≥ 130	420

### 3-way valves

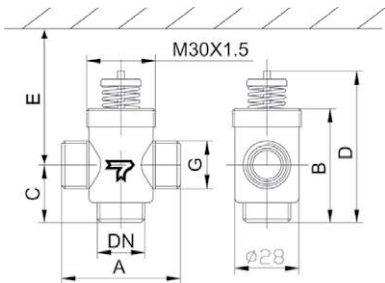

Model	G	A	B	C	D	E	Weight (g)
VTTR15	1/2"	52	52	26	68	≥ 130	116
VTTR20-2,5	3/4"	56	57	32	73	≥ 130	144
VTTR20-4,0/6,0	3/4"	78	70	45	86	≥ 130	430

### 3-way valves with bypass

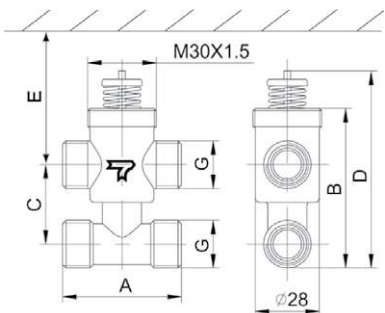

Model	G	A	B	C	D	E	Weight (g)
VTTB15	1/2"	52	70	35	62	≥ 130	164
VTTB20-2,5	3/4"	56	88	50	62	≥ 130	228
VTTB20-4,0/6,0	3/4"	78	82	44	75	≥ 130	520

# Pressure drop diagram

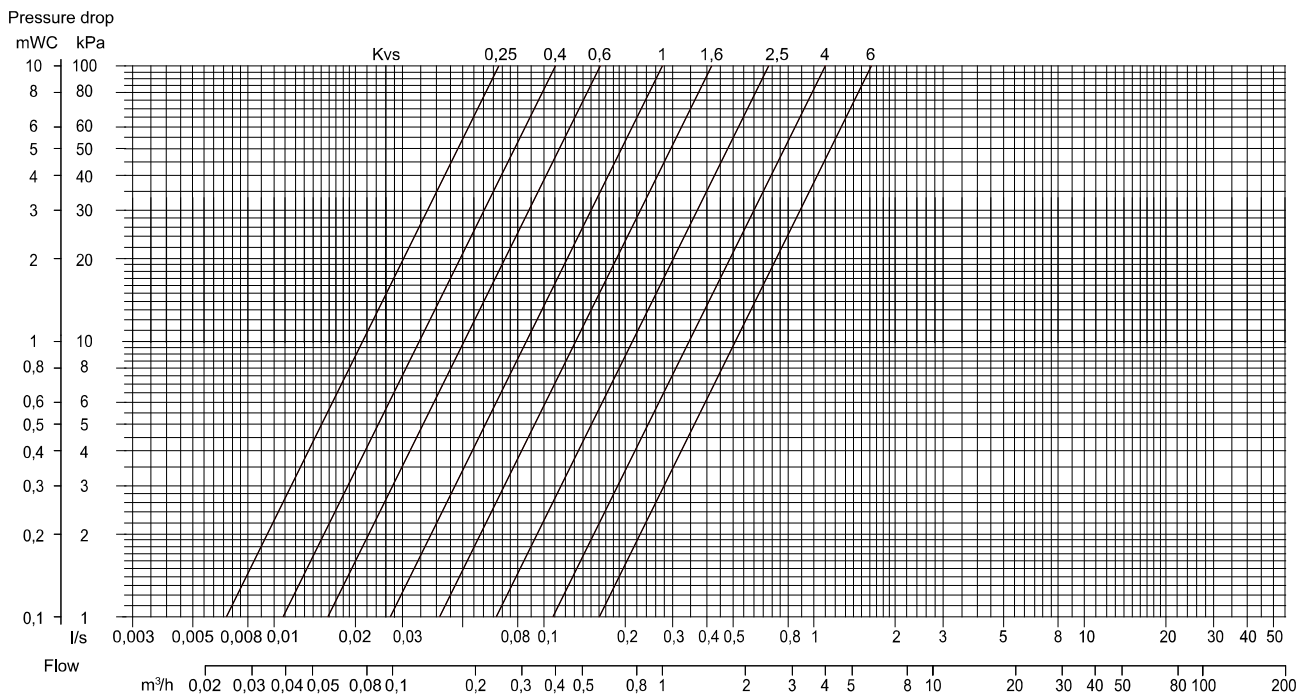

## Example: calculation of kv value

If the pressure drop is 11 kPa (A) and the flow is 0.8 m³/h (B), the kv value is 2.5 (C). See the markings in the picture to the right.

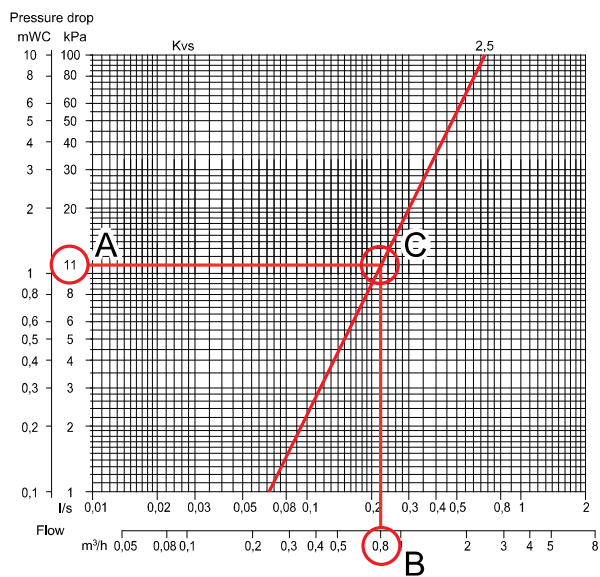



## RTAN

Thermal actuator

*Thermal actuator with position indicator for control of valves in heating or cooling systems. The actuator can be used to control radiator circuits, solar heating systems, heating or cooling coils, floor heating etc. To be combined with the VTTV/VTTR/VTTB range of valves.*

- ✓ Protection class IP40 (IP44 when vertically mounted)
- ✓ Stroke 2.5 mm
- ✓ Noiseless and maintenance-free
- ✓ Modern and compact design
- ✓ For M30 × 1.5
- ✓ 24 V AC and 230 V AC
- ✓ On/Off and 0...10 V

### Function

The actuator uses a wax element and a compression spring. It is equipped with a position indicator.

When the supply voltage is switched on the wax element is heated, causing the built-in piston to move. The force generated by the movement is transferred to the valve stem, opening and closing the valve. The valve is opened\* when the actuator stem extends outwards from the actuator. When the power is cut and the hold time has elapsed, the wax element cools and the valve is closed\* by the return spring and the inward movement of the actuator stem. The compression spring keeps the valve normally closed (NC).

\* This applies to valves that open when the stem is pushed down and close upwards with the spring against port A.

### Installation

Mount the actuator onto the thread of the valve body and tighten the metal ring. The actuator may only be mounted when it is cold, i.e. not powered up. The actuator can be mounted vertically or horizontally. It may not be mounted upside down.

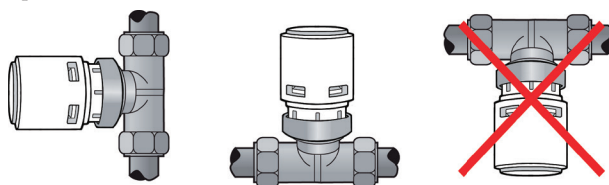

## Technical data

<b>Stroke</b>	2.5 mm
<b>Ambient temperature</b>	0...50 °C
<b>Ambient humidity</b>	10...90 % RH (non-condensing)
<b>Storage temperature</b>	-20...+70 °C
<b>Storage humidity</b>	< 95 % RH (non-condensing)
<b>Connection</b>	M30 x 1.5 metal ring
<b>Weight</b>	200 g
<b>Protection class</b>	IP40 (IP44 when vertically mounted)
<b>Default position</b>	NC (Normally closed)

## Models

Article	Supply voltage	Control signal	Force	Power consumption	Stroke time
RTAN-24	24 V AC ± 10 %, 50/60 Hz	On/Off	100 N	3.0 VA	4.5 min
RTAN-230	230 V AC ± 10 %, 50/60 Hz	On/Off	100 N	3.0 VA	3.5 min
RTAN-24A	24 V AC ± 10 %, 50/60 Hz	0...10 V DC	100 N	3.5 VA	4.5 min
RTAN140-24	24 V AC ± 10 %, 50/60 Hz	On/Off	140 N	3.0 VA	4.5 min
RTAN140-230	230 V AC ± 10 %, 50/60 Hz	On/Off	140 N	3.0 VA	3.5 min
RTAN140-24A	24 V AC ± 10 %, 50/60 Hz	0...10 V DC	140 N	3.5 VA	3.5 min

## CE

**Low Voltage Directive (LVD) standards:** This product conforms to the requirements of the European Low Voltage Directive (LVD) 2014/35/EU through product standards EN 60730-1 and EN 60730-2-14.

**EMC emissions & immunity standards:** This product conforms to the requirements of the EMC Directive 2014/30/EU through the product standards EN 60730-1 and EN 60730-2-14.

**RoHS:** This product conforms to the Directive 2011/65/EU of the European Parliament and of the Council.

## Wiring

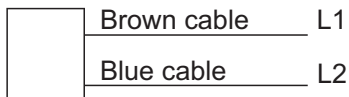

*On/off models 24 V AC*

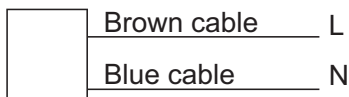

*On/off models 230 V AC*

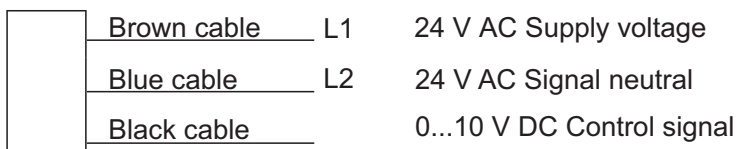

*0...10 V models*



## Dimensions

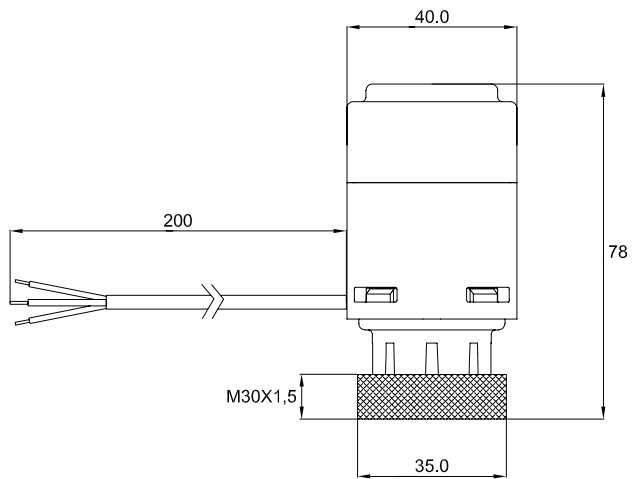

*0...10 V models*

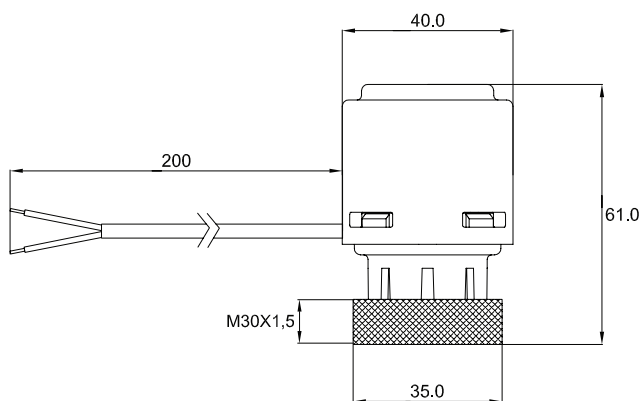

*On/off models*

Measurements in mm unless otherwise specified.

## Product documentation

Document	Description
Instruction RTAN...	Instruction for installation of RTAN...
Product sheet VTTV/VTTR/VTTB	Product sheet for VTTV/VTTR/VTTB

The documentation can be downloaded from [www.regincontrols.com](http://www.regincontrols.com).