

SYSVRF2FLOOR



GB Floor VRF indoor unit
INSTALLATION MANUAL

 **systemair**

CONTENTS	PAGE
PRECAUTIONS.....	1
INSTALLATION INFORMATION.....	2
ATTACHED FITTINGS.....	3
INDOOR UNIT INSTALLATION.....	3
INSTALL THE CONNECTING PIPE.....	6
CONNECT THE DRAIN PIPE.....	7
WIRING.....	7
ERROR CODE.....	10
TEST OPERATION.....	10

1. PRECAUTIONS

To gain full advantage of the unit's functions and to avoid malfunction due to mishandling, we recommend that you read this instruction manual carefully before use.

The precautions described here are classified as WARNING and CAUTION. They both contain important information regarding safety. Be sure to observe all precautions without fail.



WARNING

Failure to follow these instructions properly may result in personal injury or loss of life.



CAUTION

Failure to observe these instructions properly may result in property damage or personal injury, which may be serious depending on the circumstances.

After reading, keep this manual in convenient place so that you can refer to it whenever necessary. If the equipment is transferred to a new user, be sure also to hand over the manual.



WARNING

Only trained and qualified service personnel can install, repair or service the equipment.

Improper installation, repair, and maintenance may result in electric shocks, short circuits, leaks, fire or other damages to the equipment.

Strictly perform installation according to these installation instructions.

If installation is defective, it will cause water leakage, electric shocks, or fire.

When installing the unit in a small room, take measures against to keep refrigerant concentration from exceeding allowable safety limits in the event of refrigerant leakage. Contact the place of purchase for more information. Excessive refrigerant in a closed ambient can lead to oxygen deficiency.

Use the attached accessories parts and specified parts for installation.

otherwise, it will cause the set to fall, water leakage, electrical shock and fire.

Install at a strong and firm location which is able to withstand the set's weight.

If the strength is not enough or installation is not properly done, the set will drop to cause injury.

The appliance shall not be installed in the laundry.

Before obtaining access to terminals, all supply circuits must be disconnected.

The appliance must be positioned where the plug is accessible.

The enclosure of the appliance shall be marked by word, or by symbols, with the direction of the fluid flow.

Electrical work should comply with relevant national and local standard ,regulations, and this manual . An independent circuit and single outlet must be used.

If the electrical circuit capacity is not sufficient or if there is a defect in electrical work, electric shocks or fire may result.

Use the specified cable and connect tightly and clamp the cable so that no external force will be acted on the terminal.

If connection or fixing is not perfect, it will cause heat-up or fire at the connection.

Wiring routing must be properly arranged so that control board cover is fixed properly.

If control board cover is not fixed perfectly, it will cause heat-up at connection point of terminal, fire or electrical shock.

If the supply cord is damaged, it must be replaced by the manufacture or its service agent or a similarly qualified person in order to avoid a hazard.

All pole disconnection switches must be separated by 3 mm in all poles and connected with fixed wiring.

Children and the elderly should not operate this unit unless supervised by an adult .

When carrying out piping connection, do not let materials enter the refrigeration piping system.

Otherwise, capacity loss and system pressure rise will result and cause equipment damage and human injury.

Do not modify the length of the power supply cord or use the extension cord, and do not share the single outlet with other electrical appliances.

Otherwise, it will cause fire or electrical shocks.

Natural environmental factors such as typhoons and earthquakes, should be considered when installing.

Improper installation may result in the equipment toppling and falling.

If refrigerant leakage occurs, ventilate the area immediately.

Toxic gas may be produced if the refrigerant comes into contact with fire.

After completing installation, make sure that refrigerant does not leak.

The appliance must be installed in accordance with national wiring regulations.

Don't install the air conditioner in the following locations:

- There is petrolatum existing.
- There is salty air surrounding (near the coast).
- There is caustic gas (the sulfide, for example) existing in the air (near a hot spring).
- The Volt vibrates violently (in the factories).
- In buses or cabinets.
- In kitchen where it is full of oil gas.
- There is strong electromagnetic wave existing.
- There are inflammable materials or gas.
- There is acid or alkaline liquid evaporating.
- Other special conditions.



CAUTION

Ground the air conditioner.

Do not connect the ground wire to gas or water pipes, lightning rod or a telephone ground wire. Incomplete grounding may result in electric shocks.

Be sure to install an earth leakage breaker.

Failure to install an earth leakage breaker may result in electric shocks.

Connect the outdoor unit wires, then connect the indoor unit wires.

You are not allowed to connect the air conditioner with the power source until wiring and piping the air conditioner is done.

While following the instructions in this installation manual, install drain piping in order to ensure proper drainage and insulate piping in order to prevent condensation.

Improper drain piping may result in water leakage and property damage.

The appliance is not intended for use by young children or infirm persons without supervision.

DISPOSAL: Do not dispose this product as unsorted municipal waste. Collection of such waste separately for special treatment is necessary.



2. INSTALLATION INFORMATION



-
- **To install properly, please read this "installation manual" at first.**
 - **The air conditioner must be installed by qualified persons.**
 - **When installing the indoor unit or its tubing, please follow this manual as strictly as possible.**
 - **If the air conditioner is installed on a metal part of the building, it must be electrically insulated according to the relevant standards to electrical appliances.**
 - **When all the installation work is finished, please turn on the power only after a thorough check.**
 - **Regret for no further announcement if there is any change of this manual caused by product improvement.**
-

INSTALLATION ORDER

- Select the location;
- Install the indoor unit;
- Install the outdoor unit;
- Install the connecting pipe ;
- Connect the drain pipe;
- Wiring;
- Test operation.

3. ATTACHED FITTINGS

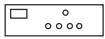
Please check whether the following fittings are of full scope. If there are some spare fittings, please restore them carefully.

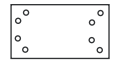
Name of Accessories	Qty	Outline	Usage
Installation manual	1	(This manual)	_____
Pipe insulation material	2		Heat insulation
Signal receiver display board	1		Receive signal
Mounting screw (ST3.9x12-C-H)	4		_____
Copper nut	1		Use for pipe connection of engineering installation
Support	1		Use for installation of display board
Cable group	1	_____	_____

4. INDOOR UNIT INSTALLATION

4.1 The units may be mounted vertically, provided that the correct clearances for positioning are maintained. (Refer to Fig. 4-1~Fig.4-5)

■ Version I

Vertical unit with casing, with air intake from front and air outlet on top, for installation on a wall or on feet on the floor.

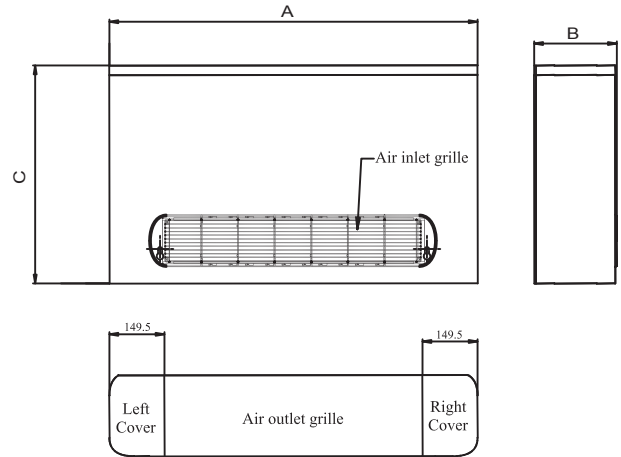

Fig. 4-1

Table.4-1

Capacity (kW)	A(mm)	B(mm)	C(mm)
2.2 ~ 2.8	1000	225	596
3.6 ~ 4.5	1200	225	596
5.6 ~ 8.0	1500	225	596



CAUTION

- Never throw or beat the controller.
- Before installation, operate the remote controller to determine its location in a reception range.
- Do not install the remote controller in a place exposed to direct sunlight or close to a heating source, such as a stove.
- Note that the positive and negative poles are right positions when loading batteries.



NOTE

This manual is subject to changes due to technological improvement without further notices.

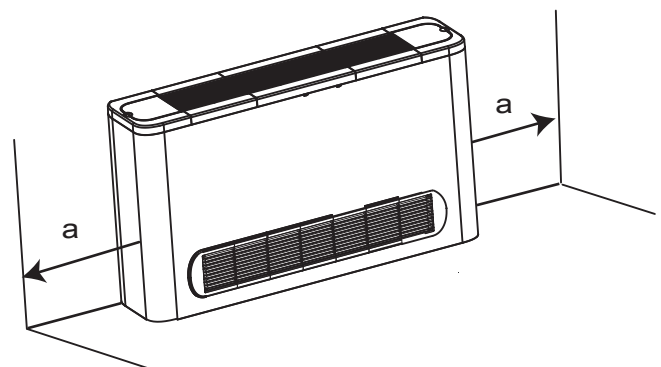

Fig. 4-2

■ **Version II**

Vertical unit with casing, with air intake from below and air outlet on top, for installation on a wall or on feet on the floor.

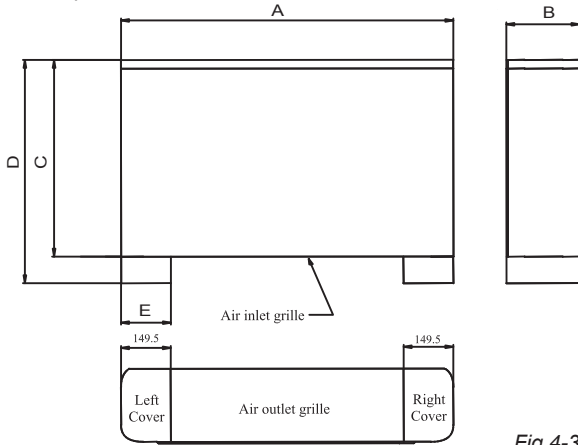

Fig.4-3

Table.4-2

Capacity (kW)	A(mm)	B(mm)	C(mm)	D(mm)	E(mm)
2.2 ~ 2.8	1000	220	596	677	150
3.6 ~ 4.5	1200	220	596	677	150
5.6 ~ 8.0	1500	220	596	677	150

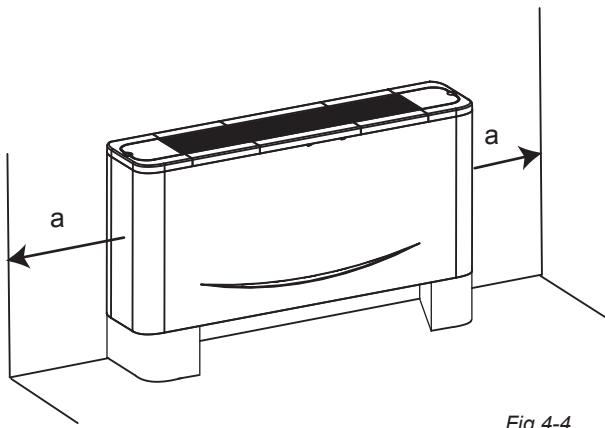

Fig.4-4

■ **Version III**

Vertical unit for building-in, with air intake from below and air delivery at the top, for installation on a wall.

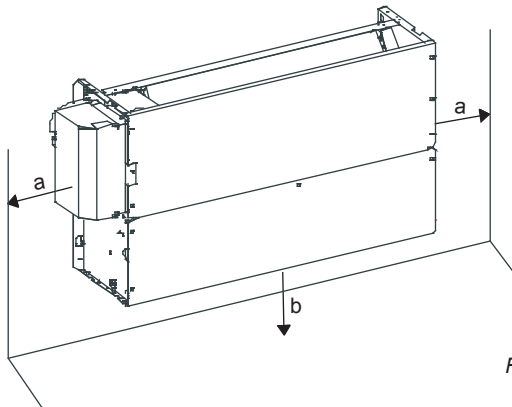

Fig.4-5

Table.4-3

Version	Version I	Version II	Version III
a(mm)	≥150	≥150	≥200
b(mm)	_____	_____	≥80

- After the selection of installation location, position the refrigerant pipes, drain pipes, indoor & outdoor wires to the connection places before hanging up the machine.
- The installation of hanging screw bolts.

WOODEN CONSTRUCTION

Put the square timber transversely over the roof beam, then install the hanging screw bolts.

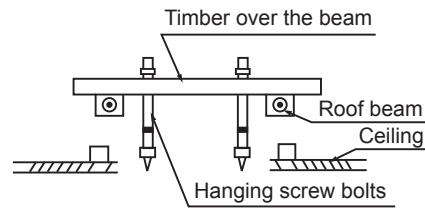

Fig.4-6

NEW CONCRETE BRICKS

Inlaying or embedding the screw bolts.



Fig.4-7

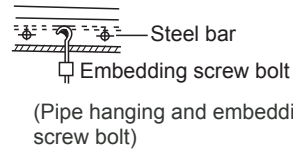

Fig.4-8

FOR ORIGINAL CONCRETE BRICKS

Install the hanging hook with expansible bolt into the concrete deep to 45~50mm to prevent loose.

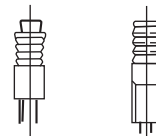

Fig.4-9

4.2 Version I Installation

For installation, follow the instructions set out below:

- Remove the external casing, unscrewing the screws which secure it to the structure, as following indicated.

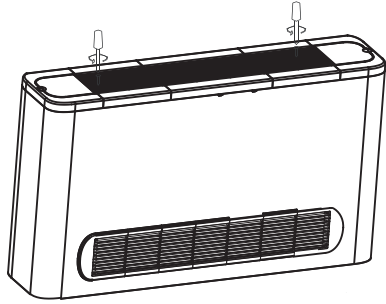

Fig. 4-10

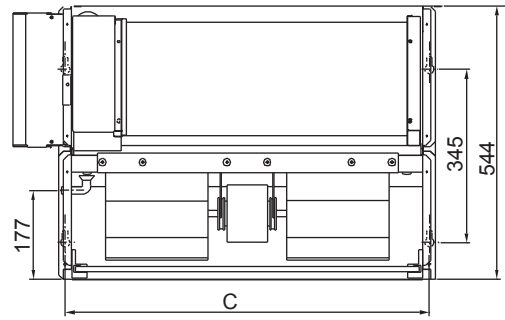

Fig. 4-12

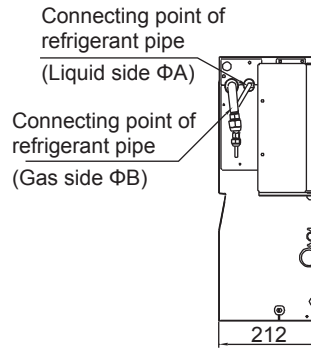

Fig. 4-13

Table.4-4

Capacity (kW)	A	B	C(mm)
2.2 ~ 2.8	Φ6.4	Φ12.7	725
3.6 ~ 4.5	Φ6.4	Φ12.7	925
5.6 ~ 8.0	Φ9.5	Φ15.9	1225

- 1) Mark out the fixing points on the wall, either by marking through the drillings in the unit itself, or by referring to the measurements given in Table.4-2.
- 2) Secure the unit by driving the four fixing screws into suitable masonry plugs.

4.3 Version II Installation

For installation, follow the instructions set out below:

- Remove the external casing, unscrewing the screws which secure it to the structure.

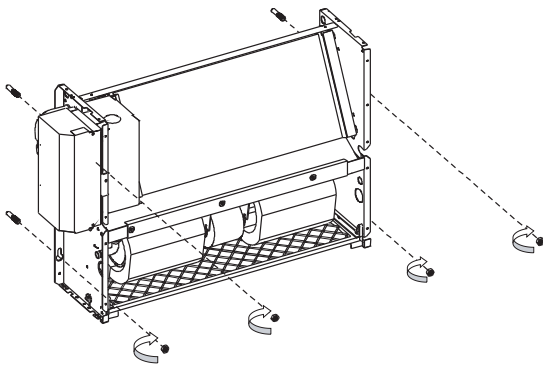

Fig. 4-11

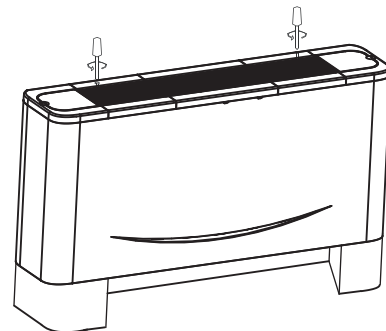

Fig. 4-14

- Put the unit onto the feet, and fix it by screws.

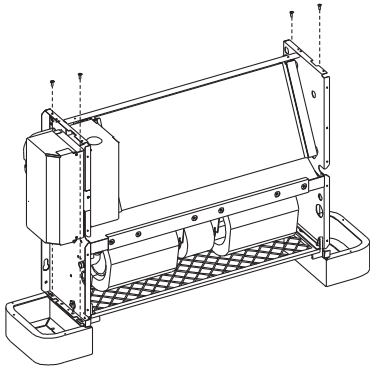

Fig. 4-15

- 1) Mark out the fixing points on the wall, either by marking through the drillings in the unit itself, or by referring to the measurements given in Table.4-2.
- 2) Secure the unit by driving the four fixing screws into suitable masonry plugs. (Refer to Fig.4-18)

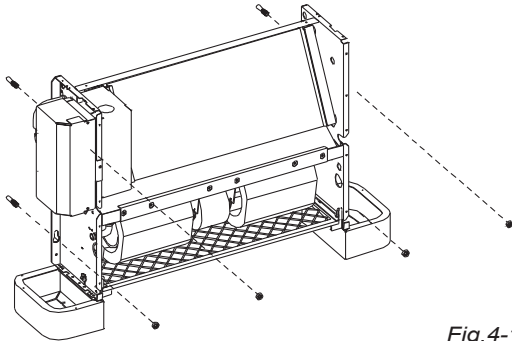

Fig. 4-16

4.4 Version III Installtion

For installation, follow the instructions set out below:

- 1) Mark out the fixing points on the wall, either by marking through the drillings in the unit itself, or by referring to the measurements given in Table.4-2.
- 2) Secure the unit by driving the four fixing screws into suitable masonry plugs. (Refer to Fig.4-19)

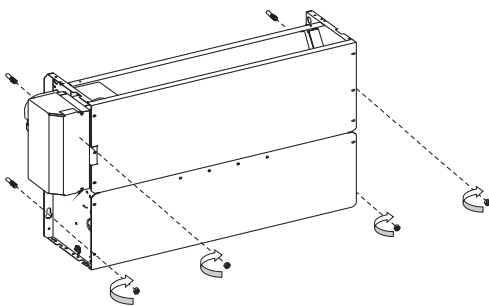

Fig. 4-17



ATTENTION

The figures above are based on model with 2.2kW~2.8kW type as rated capacity, which may differ from the unit you purchased.

5. INSTALL THE CONNECTING PIPE



CAUTION

Do not let air, dust, or other impurities fall in the pipe system during the time of installation.
The connecting pipe should not be installed until the indoor and outdoor units have been fixed already.
Keep the connecting pipe dry, and do not let moisture in during installation.

5.1 The Procedure of Connecting Pipes

5.1.1 Measure the necessary length of the connecting pipe, and make it by the following way.

- 1) Connect the indoor unit at first, then the outdoor unit.
 - a. Bend the tubing in proper way. Don't harm them.



CAUTION

1. Daub the surfaces of the flare pipe and the joint nuts with frozen oil, and wrench it for 3~4 rounds with hands before fasten the flare nuts.
2. Be sure to use two wrenches simultaneously when you connect or disconnect the pipes.

2) The stop valve of the outdoor unit should be closed absolutely (as original state). Every time you connect it, first loosen the nuts at the part of stop valve, then connect the flare pipe immediately (in 5 minutes). If the nuts have been loosened for a long time, dusts and other impurities may enter the pipe system and may cause malfunction later. So please expel the air out of the pipe with refrigerant before connection.

3) Expel the air (refer to the "Expel The Air") after connecting the refrigerant pipe with the indoor unit and the outdoor unit. Then fasten the nuts at the repair-points.

■ Notices For Benable pipe.

- The bending angle should not exceed 90°.
- Bending position is preferably in the bendable pipe. The larger the better it is.
- Do not bend the pipe more than three times.

■ Bend the connecting pipe of small wall thickness.

- Cut out a desired concave at the bending part of the insulating pipe.
- Then expose the pipe (cover it with tapes after bending). To prevent collapsing of deforming, please bend the pipe at its biggest radius.
- Use bender to get a small radius pipes.

■ Use the market brass pipe.

Be sure to use the same insulating materials when you buy the brass pipe. (More than 9mm thick)

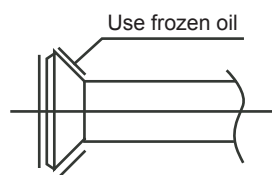

Fig. 5-1

Bend the pipe with thumb



Min-radius 100mm

Fig. 5-2

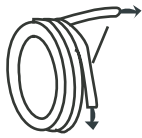

Make the ends straight

Fig. 5-3

2. Locate The Pipe

- 1) Drill a hole in the wall (suitable just for the size of the wall conduit, 90mm in general), then set on the fittings such as the wall conduit and its cover.
- 2) Bind the connecting pipe and the cables together tightly with binding tapes. Do not let air in, which will cause water leakage by condensation.
- 3) Pass the bound connecting pipe through the wall conduit from outside. Be careful of the pipe allocation to do no damage to the tubing.
3. Connect the pipes.
4. Then, open the stem of stop valves of the outdoor unit to make the refrigerant pipe connecting the indoor unit with the outdoor unit fluently flow.
5. Be sure of no leakage by checking it with leak detector or soap water.
6. Cover the joint of the connecting pipe to the indoor unit with the soundproof/insulating sheath (fittings), and bind it well with the tapes to prevent leakage.

6. CONNECT THE DRAIN PIPE

6.1 Install the drainpipe of the indoor unit

The outlet has PTI screw bread, Please use sealing materials and pipe sheath(fitting) when connecting PVC pipes.



CAUTION

- The drain pipe of indoor unit must be heat insulated, or it will condense dew, as well as the connections of the indoor unit.
- Hard PVC binder must be used for pipe connection, and make sure there is no leakage.
- With the connection part to the indoor unit, please be noted not to impose pressure on the side of indoor unit pipes.
- When the declivity of the drain pipe downwards is over 1/100, there should not be any winding.
- The total length of the drain pipe when pulled out transversely shall not exceed 20m, when the pipe is over long, a prop stand must be installed to prevent winding.
- Refer to the Fig.6-1 for the installation of the pipes.

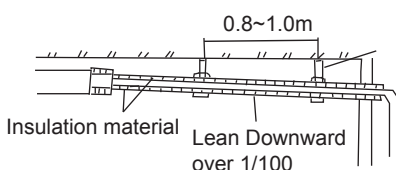

Fig. 6-1

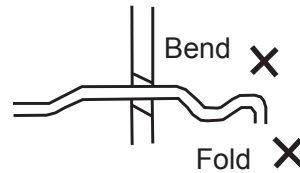

Fig. 6-2

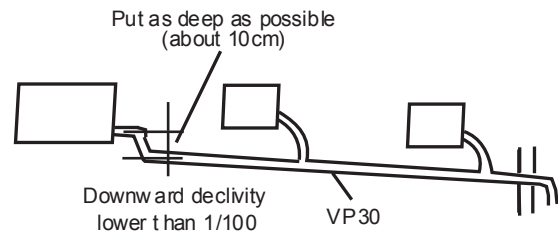

Fig. 6-3

6.2 Drainage test

- Check whether the drainpipe is unhindered.
- New built house should have this test done before paving the ceiling.

7. WIRING

- Specified power cables should be used. Do not apply any pressure on the terminals used to connect. Improper connection may cause fire.
- Grounding must be properly done. The grounding wire should be away from gas pipes, water pipes, telephone, lightening rods or other grounding wires. Improper grounding may cause electric shock.
- Electric Wiring must be done by professionals. Use a separate circuit according to national regulations. If the wiring capacity is not enough, electric shock or fire may occur.



CAUTION

1. Be sure to Install Current Leakage Protection Switch, or electric shock may occur.
2. Power cord is to be selected according to national regulations.
3. Outdoor unit power cord should be selected and connected according to the outdoor unit installation manual.
4. Wiring should be away from high temperature components, or the insulation layer of the wires may melt down.
5. Use wire clamp to fix the wires and terminal block after connection.
6. Control wire should be wrapped together with heat insulated refrigerant pipes.
7. Connect the indoor unit to power only after the refrigerant has been vacuumed.
8. Don't connect the power wire to the signal wire connection end.

7.1 The specification of power

Table.7-1

TYPE (kW)		2.2-8.0
Power	Phase	1-PHASE
	Frequency & volt	220-240V~ 50Hz 220-240V~ 50Hz/60Hz
Manual switch/fuse (A)		15/15
Indoor/outdoor connecting wire (mm ²)	Ground wiring	2.0
	Weak electric signal	1.0



CAUTION

A disconnection device having an air gap contact separation in all active conductors should be incorporated in the fixed wiring according to the National Wiring Regulation.

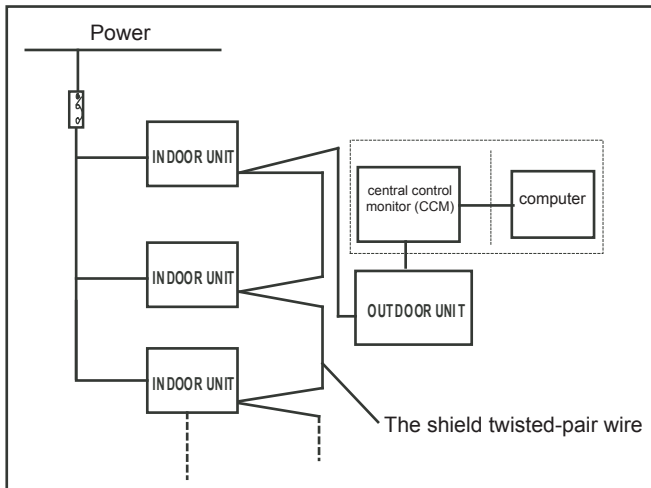

Fig. 7-1



CAUTION

The reserved function is indicated in broken line table, users can select it when necessary.

7.2 Indoor/outdoor unit signal wire

- Connect the wire according to their numbers.
- Wrong connection may cause malfunction .

7.3 Wiring connection

- Seal the wiring connection with the insulation material , or the condensing dew will be caused.

7.4 Panel Wiring

Connect the Swing Motor terminal block according to the Panel Installation Manual.

7.5 Terminal Board Diagram

Please refer to the indoor unit wiring diagram for the wiring.

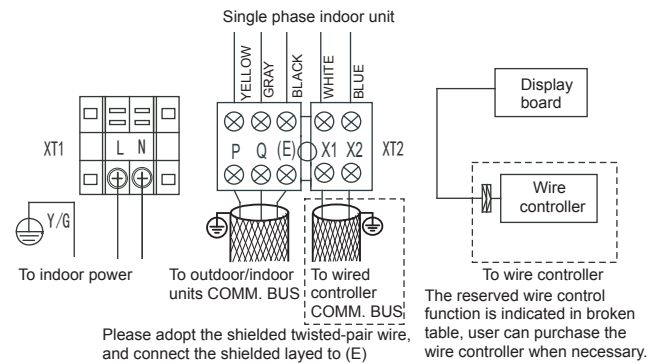

Fig. 7-2

7.6 Control

Please number the indoor units during the installation . For example, for the first outdoor unit ,the number of the first indoor unit is 1-1, the second indoor unit is 1-2, and the set address is 1 and 2 respectively , the others is analogical.

7.7 Horsepower set

Horsepower code

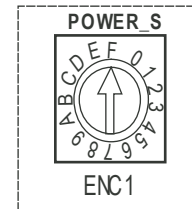

Fig. 7-3

Base on different purposes to setting the switch cords on PC panel of indoor electrical control box. Once finish the setting, please cut off the main power, and then input power again, other wise, setting function could not work.

Table 7-2

ENC1	Toggle switch	For set horsepower
Note: The horsepower has been set before leaving the factory ,anyone can't modify it except the maintenance person.	Code	Capacity(Horsepower)
	0	2200W(0.8HP)
	1	2800W(1.0HP)
	2	3600W(1.2HP)
	3	4500W(1.7HP)
	4	5600W(2.0HP)
	5	7100W(2.5HP)
6	8000W(3.0HP)	



CAUTION

The system together have 64units(0-63),everyone has only system addresscode,If two addresses are the same in one system , the abnormal operation will occur.













Please switch off the power before setting,otherwise the unexpected error will occur.

7.8 Network address set

1) Network address is set by communication of indoor and outdoor unit; the address is the same as indoor address, there is no need to set separately.

7.9 Main board Code designation

Table 7-3

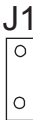
0/1 definition of each dial code switch:		ON  means 0	ON  means 1
ON  SW1 12	<ul style="list-style-type: none"> 0 means cooling mode temperature compensation is 0°C (default) 1 means cooling mode temperature compensation is 2°C 		<ul style="list-style-type: none"> 00 means shutting down the unit to "stop cold air" at 15 C (default) 01 means shutting down the unit to "stop cold air" at 20 C 10 means shutting down the unit to "stop cold air" at 24 C 11 means shutting down the unit to "stop cold air" at 26 C
ON  SW1 12	<ul style="list-style-type: none"> 0 means EXV positions 96 (steps) in standby heating mode (default) 1 means EXV positions 72 (steps) in standby heating mode 	ON  SW5 12	
ON  SW2 12	Reserved (Default 0)		<ul style="list-style-type: none"> 00 means temp. compensation value is 6°C under heat mode (default) 01 means temp. compensation value is 2°C under heat mode 10 means temp. compensation value is 4°C under heat mode 11 means temp. compensation value is 0°C under heat mode(follow me)
ON  SW2 12	Reserved (Default 0)	ON  SW6 12	
ON  SW3 12	<ul style="list-style-type: none"> 0 means auto addressing mode (default) 1 means clear indoor unit address 	ON  SW7 12	Reserved (Default 0)
ON  SW3 12	Reserved (Default 0)	ON  SW7 12	Reserved (Default 0)
ON  SW4 12	<ul style="list-style-type: none"> 00 means the time of stopping TERMAL fan is 4 minutes (default) 01 means the time of stopping TERMAL fan is 8 minutes 10 means the time of stopping TERMAL fan is 12 minutes 11 means the time of stopping TERMAL fan is 16 minutes 	J1 	<ul style="list-style-type: none"> Not wire jumper means has power-off memory Has wire jumper means no power-off memory

8. ERROR CODE

Table 8-1

Error Code	Error Content
FE	No address when first time power on
H0	M-Home not matched error(Reserved)
E0	Mode conflict
E1	Communication error of indoor and outdoor units
E2	Error of indoor temp. sensor (T1)
E3	Error of pipe temp. sensor (T2)
E4	Error of pipe temp. sensor (T2B)
E5	Reserved
E6	DC FAN error
E7	EEPROM error
Eb	Error of electronic expansion valve
Ed	Outdoor unit error
EE	Water level alarm

9. TEST OPERATION

- 1 The test operation must be carried out after the entire installation has been completed.
- 2 Please confirm the following points before the test operation:
 - The indoor unit and outdoor unit are installed properly.
 - Tubing and wiring are correctly completed.
 - The refrigerant pipe system is leakage-checked.
 - The drainage is unimpeded.
 - The heating insulation works well.
 - The ground wiring is connected correctly.
 - The length of the tubing and the added stow capacity of the refrigerant have been recorded.
 - The power voltage fits the rated voltage of the air conditioner.
 - There is no obstacle at the outlet and inlet of the outdoor and indoor units.
 - The gas-side and liquid-side stop valves are both opened.
 - The air conditioner is pre-heated by turning on the power.
- 3 According to the user's requirement, install the remote controller frame where the remote controller's signal can reach the indoor unit smoothly.
- 4 Test operation
 - Set the air conditioner under the mode of "COOLING" with the remote controller, and check the following points. If there is any malfunction, please resolve it according to the chapter "Troubleshooting" in the "Owner's Manual".
 - 1) The indoor unit
 - a. Whether the switch on the remote controller works well.
 - b. Whether the buttons on the remote controller works well.
 - c. Whether the air flow louver moves normally.
 - d. Whether the room temperature is adjusted well.
 - e. Whether the indicator lights normally.
 - f. Whether the temporary buttons works well.
 - g. Whether the drainage is normal.
 - h. Whether there is vibration or abnormal noise during operation.
 - i. Whether the air conditioner heats well in the case of the HEATING/COOLING type.
 - 2) The outdoor unit
 - a. Whether there is vibration or abnormal noise during operation.
 - b. Whether the generated wind, noise, or condensed of by the air conditioner have influenced your neighborhood.
 - c. Whether any of the refrigerant is leaked.



CAUTION

A protection feature prevents the air conditioner from being activated for approximately 3 minutes when it is restarted immediately after shut off.

